

# NCP565/NCV565

## 1.5 A Low Dropout Linear Regulator

The NCP565/NCV565 low dropout linear regulator will provide 1.5 A at a fixed output voltage or an adjustable voltage down to 0.9 V. The fast loop response and low dropout voltage make this regulator ideal for applications where low voltage and good load transient response are important. Device protection includes current limit, short circuit protection, and thermal shutdown.

### Features

- Ultra Fast Transient Response ( $< 1.0 \mu\text{s}$ )
- Low Ground Current (1.1 mA @  $I_{\text{load}} = 1.5 \text{ A}$ )
- Low Dropout Voltage (0.9 V @  $I_{\text{load}} = 1.5 \text{ A}$ )
- Low Noise (28  $\mu\text{V}_{\text{rms}}$ )
- 0.9 V Reference Voltage
- Adjustable Output Voltage from 7.7 V down to 0.9 V
- 1.2 V Fixed Output Version. Other Fixed Voltages Available on Request
- Current Limit Protection (3.5 A Typ)
- Thermal Shutdown Protection (160°C)
- Pb-Free Packages are Available

### Typical Applications

- Servers
- ASIC Power Supplies
- Post Regulation for Power Supplies
- Constant Current Source



**ON Semiconductor®**

<http://onsemi.com>

### MARKING DIAGRAMS

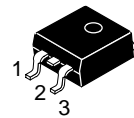

**D<sup>2</sup>PAK  
CASE 936  
FIXED**

Tab = Ground  
Pin 1.  $V_{\text{in}}$   
2. Ground  
3.  $V_{\text{out}}$

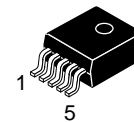
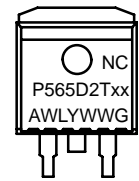

**D<sup>2</sup>PAK  
CASE 936A  
ADJUSTABLE**

Tab = Ground  
Pin 1. N.C.  
2.  $V_{\text{in}}$   
3. Ground  
4.  $V_{\text{out}}$   
5. Adj

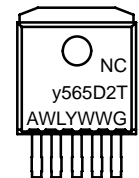

xx = 12 or 33  
y = P or V  
A = Assembly Location  
WL = Wafer Lot  
Y = Year  
WW = Work Week  
G = Pb-Free



**DFN6  
CASE 506AX**

xx = Voltage Rating  
AJ = Adjustable  
12 = 1.2 V  
33 = 3.3 V



**SOT-223  
CASE 318E**

yy = Voltage Rating  
12 = 1.2 V  
A = Assembly Location  
Y = Year  
WW = Work Week  
M = Date Code  
▪ = Pb-Free Package

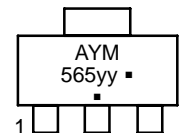

Tab =  $V_{\text{out}}$   
Pin 1. Ground  
2.  $V_{\text{out}}$   
3.  $V_{\text{in}}$

(Note: Microdot may be in either location)

### ORDERING INFORMATION

See detailed ordering and shipping information in the package dimensions section on page 12 of this data sheet.

# NCP565/NCV565

## PIN DESCRIPTION

D <sup>2</sup> PAK		DFN6		SOT-223	Symbol	Description
Pin No. Adj. Version	Pin No. Fixed Version	Pin No. Adj. Version	Pin No. Fixed Version	Pin No. Fixed Version		
1	–	1, 2	1, 2, 5	–	N.C.	–
2	1	3	3	3	V <sub>in</sub>	Positive Power Supply Input Voltage
3, Tab	2, Tab	6	6	1	Ground	Power Supply Ground
4	3	4	4	2, Tab	V <sub>out</sub>	Regulated Output Voltage
5	–	5	–	–	Adj	This pin is to be connected to the R <sub>sense</sub> resistors on the output. The linear regulator will attempt to maintain 0.9 V between this pin and ground. Refer to Figure 1 for the equation.

## MAXIMUM RATINGS

Rating	Symbol	Value	Unit
Input Voltage (Note 1)	V <sub>in</sub>	9.0	V
Output Pin Voltage	V <sub>out</sub>	–0.3 to V <sub>in</sub> + 0.3	V
Adjust Pin Voltage	V <sub>adj</sub>	–0.3 to V <sub>in</sub> + 0.3	V
Thermal Characteristics SOT-223 (Notes 2, 3) Thermal Resistance, Junction-to-Ambient Thermal Resistance, Junction-to-Pin	R <sub>θJA</sub> R <sub>θJP</sub>	107 12	°C/W
Thermal Characteristics DFN6 3x3 (Notes 2, 3) Thermal Resistance, Junction-to-Ambient Thermal Resistance, Junction-to-Pin	R <sub>θJA</sub> R <sub>θJP</sub>	176 37	°C/W
Thermal Characteristics D <sup>2</sup> PAK (5ld) (Notes 2, 3) Thermal Resistance, Junction-to-Case Thermal Resistance, Junction-to-Ambient Thermal Resistance, Junction-to-Pin	R <sub>θJC</sub> R <sub>θJA</sub> R <sub>θJP</sub>	3 105 4	°C/W
Operating Junction Temperature Range	T <sub>J</sub>	–40 to 150	°C
Operating Ambient Temperature Range	T <sub>A</sub>	–40 to 125	°C
Storage Temperature Range	T <sub>stg</sub>	–55 to 150	°C

Stresses exceeding Maximum Ratings may damage the device. Maximum Ratings are stress ratings only. Functional operation above the Recommended Operating Conditions is not implied. Extended exposure to stresses above the Recommended Operating Conditions may affect device reliability.

- This device series contains ESD protection and exceeds the following tests:

Human Body Model JESD 22-A114-B

Machine Model JESD 22-A115-A

- The maximum package power dissipation is:

$$P_D = \frac{T_{J(max)} - T_A}{R_{\theta JA}}$$

- As measured using a copper heat spreading area of 50 mm<sup>2</sup>.

# NCP565/NCV565

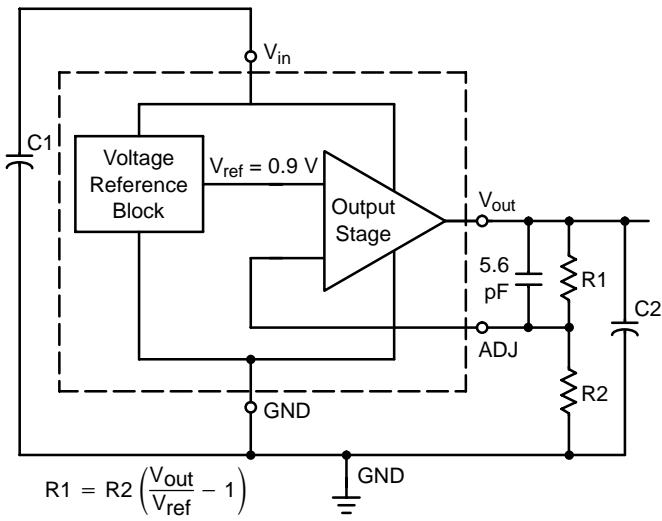

Figure 1. Typical Schematic, Adjustable Output

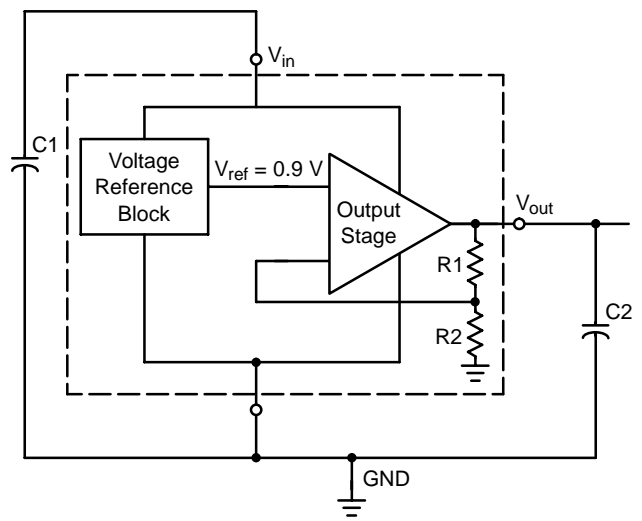

Figure 2. Typical Schematic, Fixed Output

## NCP565/NCV565

### ELECTRICAL CHARACTERISTICS ( $V_{in} = V_{out} + 1.3$ V, $V_{out} = 0.9$ V, $T_J = 25^\circ\text{C}$ , $C_{in} = C_{out} = 150$ $\mu\text{F}$ , unless otherwise noted.)

Characteristic	Symbol	Min	Typ	Max	Unit
<b>ADJUSTABLE OUTPUT VERSION</b>					
Reference Voltage (10 mA < $I_{out}$ < 1.5 A; $V_{out} + 1.6$ V < $V_{in}$ < 9.0 V; $T_J = -10$ to $105^\circ\text{C}$ )	$V_{ref}$	0.882 (-2%)	0.9	0.918 (+2%)	V
Reference Voltage (10 mA < $I_{out}$ < 1.5 A; $V_{out} + 1.6$ V < $V_{in}$ < 9.0 V; $T_J = -40$ to $125^\circ\text{C}$ )	$V_{ref}$	0.873 (-3%)	0.9	0.927 (+3%)	V
ADJ Pin Current	$I_{Adj}$	-	30	-	nA
Line Regulation ( $I_{out} = 10$ mA)	$Reg_{line}$	-	0.03	-	%
Load Regulation (10 mA < $I_{out}$ < 1.5 A)	$Reg_{load}$	-	0.03	-	%
Dropout Voltage ( $I_{out} = 1.5$ A, $V_{out} = 2.5$ V) (Note 4)	$V_{do}$	-	0.9	1.3	V
Current Limit	$I_{lim}$	1.6	3.5	-	A
Ripple Rejection (120 Hz; $I_{out} = 1.5$ A)	RR	-	85	-	dB
Ripple Rejection (1 kHz; $I_{out} = 1.5$ A)	RR	-	75	-	dB
Ground Current ( $I_{out} = 1.0$ mA to 1.5 A)	$I_{GND}$	-	1.1	3.0	mA
Output Noise Voltage ( $f = 100$ Hz to 100 kHz, $I_{out} = 1.5$ A)	$V_n$	-	28	-	$\mu\text{V}_{rms}$

### FIXED OUTPUT VOLTAGE ( $V_{in} = V_{out} + 1.3$ V, $T_J = 25^\circ\text{C}$ , $C_{in} = C_{out} = 150$ $\mu\text{F}$ , unless otherwise noted.)

Output Voltage (10 mA < $I_{out}$ < 1.5 A; $V_{out} + 1.6$ V < $V_{in}$ < 9.0 V; $T_J = -10$ to $105^\circ\text{C}$ ) 1.2 V version	$V_{out}$	1.176 (-2%)	1.2	1.224 (+2%)	V
Output Voltage (10 mA < $I_{out}$ < 1.5 A; $V_{out} + 1.6$ V < $V_{in}$ < 9.0 V; $T_J = -40$ to $125^\circ\text{C}$ ) 1.2 V version	$V_{out}$	1.164 (-3%)	1.2	1.236 (+3%)	V
Output Voltage (10 mA < $I_{out}$ < 1.5 A; $V_{out} + 1.6$ V < $V_{in}$ < 9.0 V; $T_J = -10$ to $105^\circ\text{C}$ ) 3.3 V version	$V_{out}$	3.234 (-2%)	3.3	3.366 (+2%)	V
Output Voltage (10 mA < $I_{out}$ < 1.5 A; $V_{out} + 1.6$ V < $V_{in}$ < 9.0 V; $T_J = -40$ to $125^\circ\text{C}$ ) 3.3 V version	$V_{out}$	3.201 (-3%)	3.3	3.399 (+3%)	V
Line Regulation ( $I_{out} = 10$ mA)	$Reg_{line}$	-	0.03	-	%
Load Regulation (10 mA < $I_{out}$ < 1.5 A)	$Reg_{load}$	-	0.03	-	%
Dropout Voltage ( $I_{out} = 1.5$ A, $V_{out} = 2.5$ V) (Note 4)	$V_{do}$	-	0.9	1.3	V
Current Limit	$I_{lim}$	1.6	3.5	-	A
Ripple Rejection (120 Hz; $I_{out} = 1.5$ A)	RR	-	85	-	dB
Ripple Rejection (1 kHz; $I_{out} = 1.5$ A)	RR	-	75	-	dB
Ground Current ( $I_{out} = 1.0$ mA to 1.5 A)	$I_{GND}$	-	1.1	3.0	mA
Output Noise Voltage ( $f = 100$ Hz to 100 kHz, $I_{out} = 1.5$ A)	$V_n$	-	28	-	$\mu\text{V}_{rms}$

4. Dropout voltage is a measurement of the minimum input/output differential at full load.

# NCP565/NCV565

## TYPICAL CHARACTERISTICS

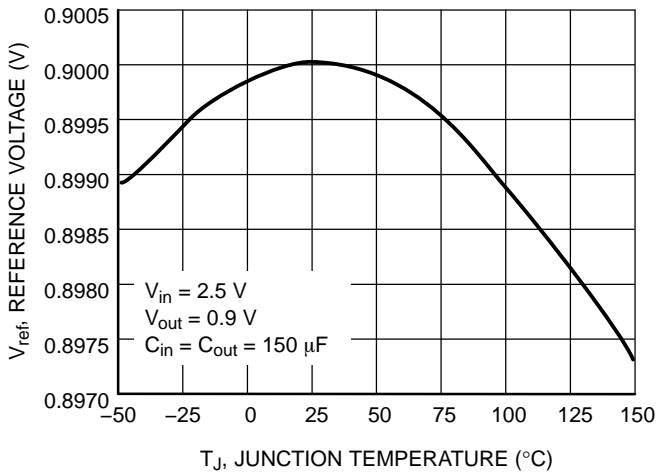

Figure 3. Output Voltage vs. Temperature

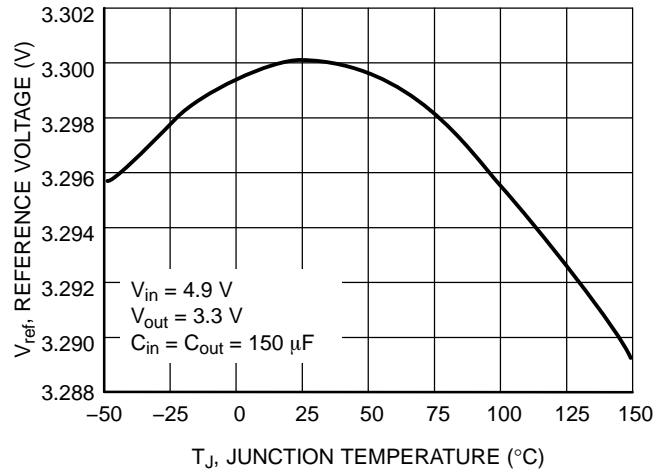

Figure 4. Output Voltage vs. Temperature

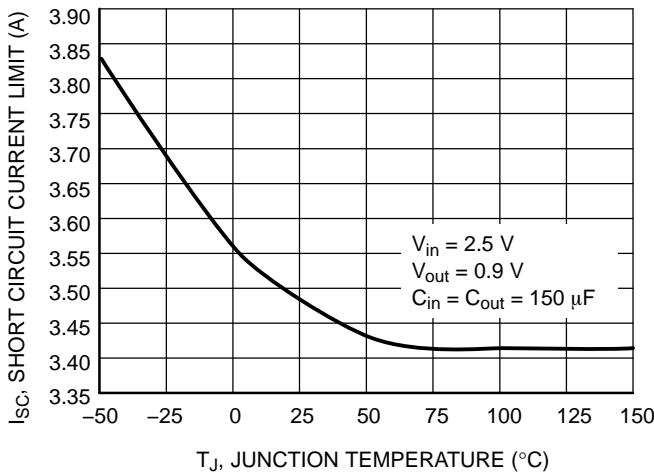

Figure 5. Short Circuit Current Limit vs. Temperature

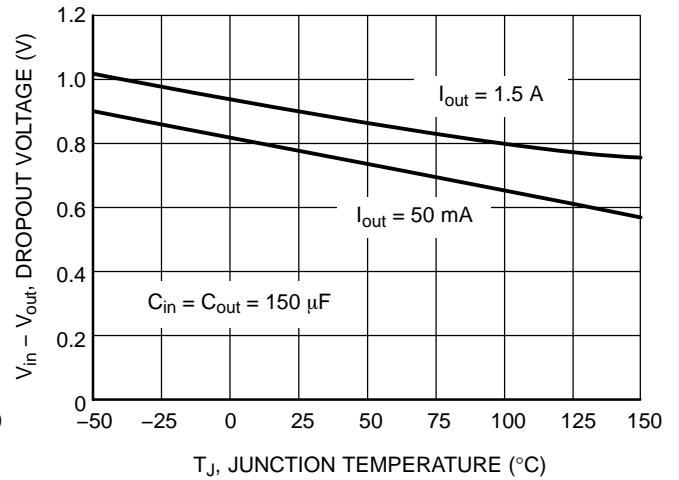

Figure 6. Dropout Voltage vs. Temperature

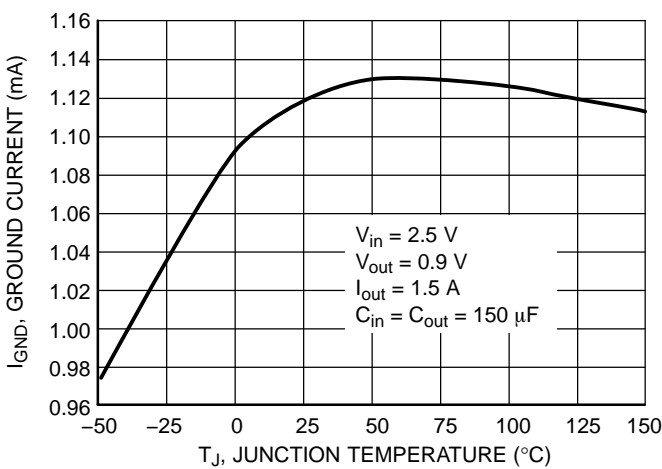

Figure 7. Ground Current vs. Temperature

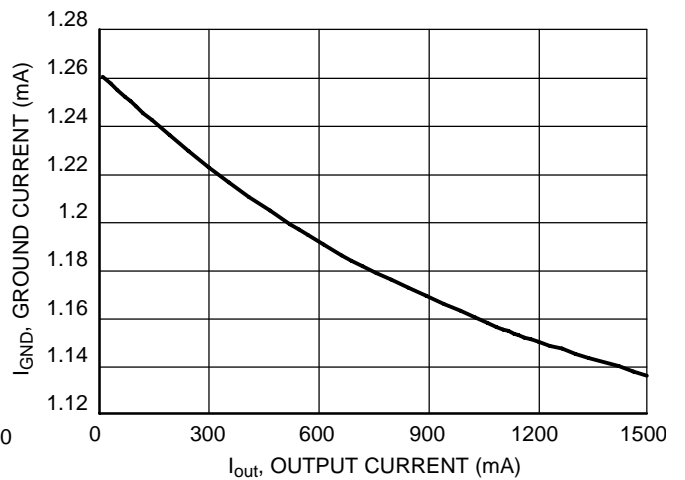

Figure 8. Ground Current vs. Output Current

# NCP565/NCV565

## TYPICAL CHARACTERISTICS

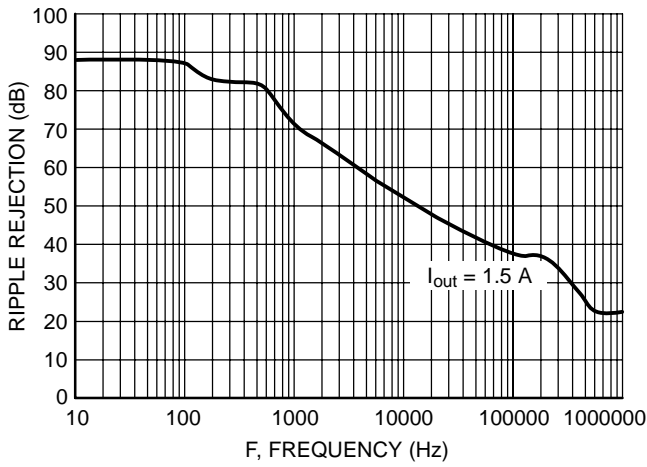

Figure 9. Ripple Rejection vs. Frequency

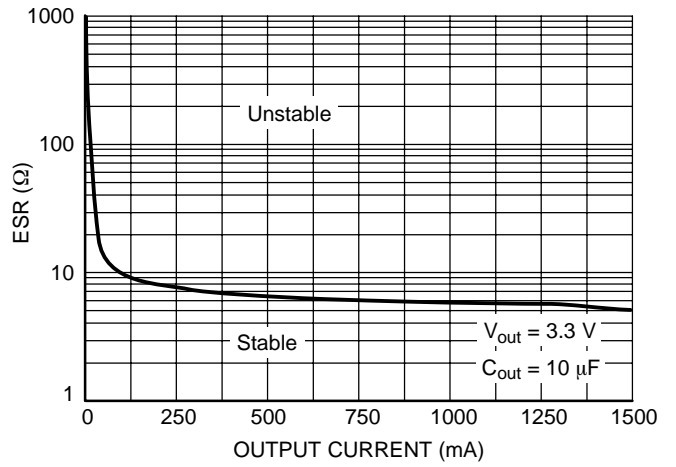

Figure 10. Output Capacitor ESR Stability vs. Output Current

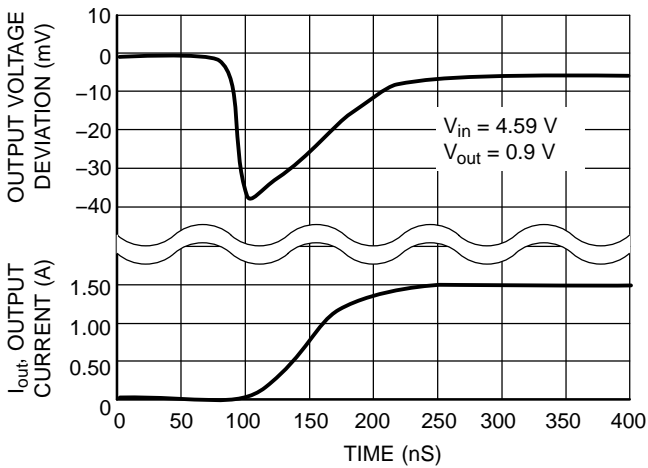

Figure 11. Load Transient from 10 mA to 1.5 A

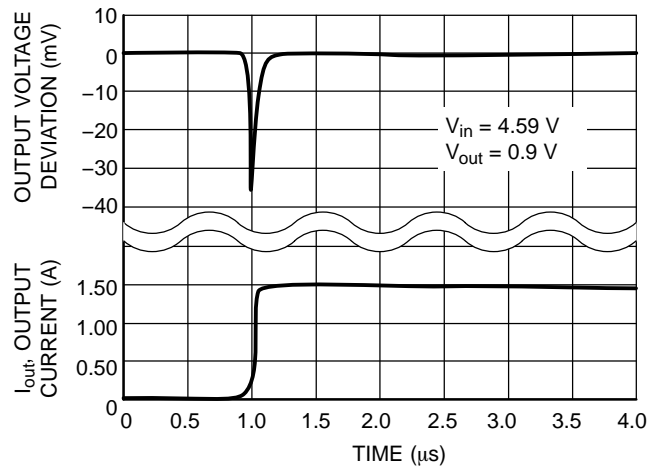

Figure 12. Load Transient from 10 mA to 1.5 A

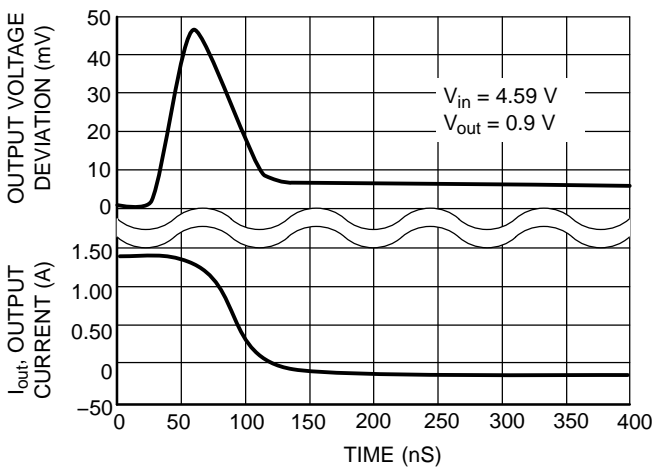

Figure 13. Load Transient from 1.5 A to 10 mA

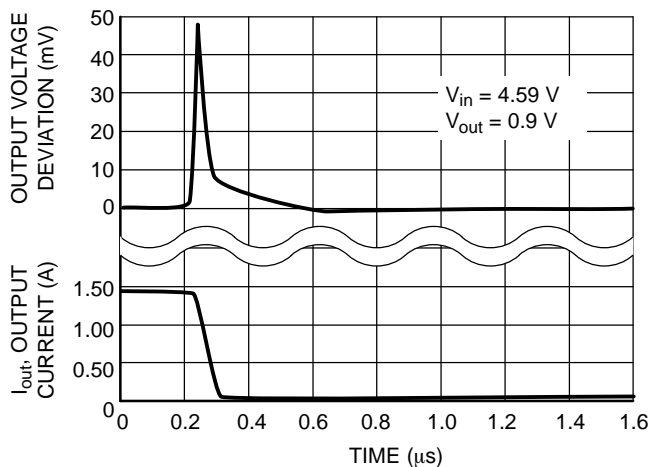

Figure 14. Load Transient from 1.5 A to 10 mA

# NCP565/NCV565

## TYPICAL CHARACTERISTICS

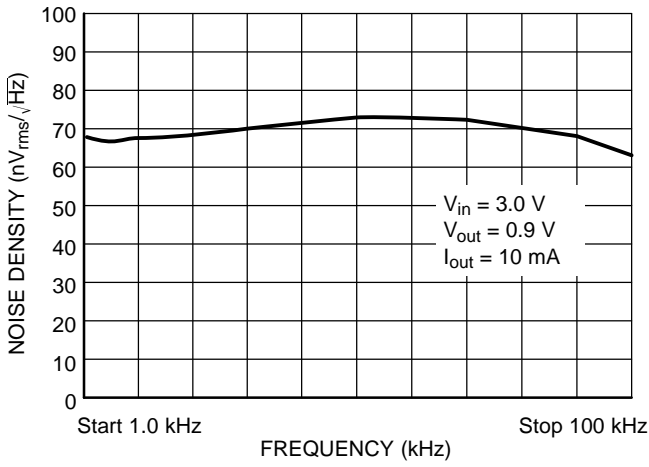

Figure 15. Noise Density vs. Frequency

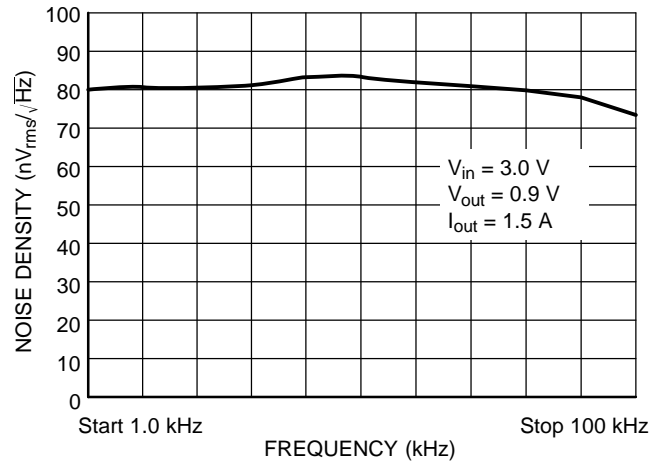

Figure 16. Noise Density vs. Frequency

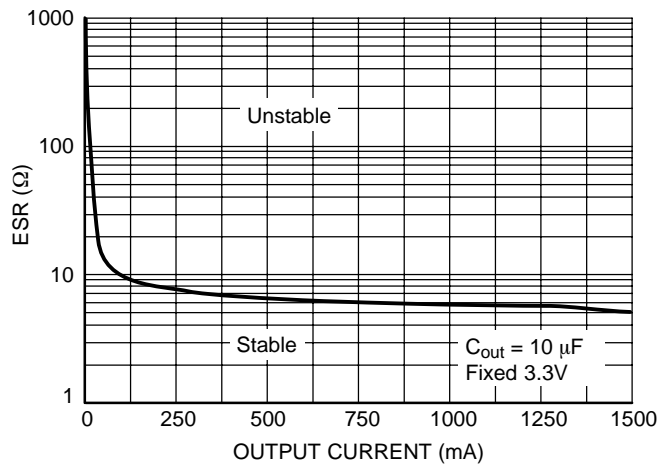

Figure 17. Output Capacitor ESR Stability vs. Output Current

## NCP565/NCV565

### APPLICATION INFORMATION

The NCP565 low dropout linear regulator provides adjustable voltages at currents up to 1.5 A. It features ultra fast transient response and low dropout voltage. These devices contain output current limiting, short circuit protection and thermal shutdown protection.

#### Input, Output Capacitor and Stability

An input bypass capacitor is recommended to improve transient response or if the regulator is located more than a few inches from the power source. This will reduce the circuit's sensitivity to the input line impedance at high frequencies and significantly enhance the output transient response. Different types and different sizes of input capacitors can be chosen dependent on the quality of power supply. A 150  $\mu\text{F}$  OSCON 16SA150M type from Sanyo should be adequate for most applications. The bypass capacitor should be mounted with shortest possible lead or track length directly across the regulator's input terminals.

The output capacitor is required for stability. The NCP565 remains stable with ceramic, tantalum, and aluminum-electrolytic capacitors with a minimum value of 1.0  $\mu\text{F}$  as long as the ESR remains between 50 m $\Omega$  and 2.5  $\Omega$ . The NCP565 is optimized for use with a 150  $\mu\text{F}$  OSCON 16SA150M type in parallel with a 10  $\mu\text{F}$  OSCON 10SL10M type from Sanyo. The 10  $\mu\text{F}$  capacitor is used for best AC stability while 150  $\mu\text{F}$  capacitor is used for achieving excellent output transient response. The output capacitors should be placed as close as possible to the output pin of the device. If not, the excellent load transient response of NCP565 will be degraded.

#### Adjustable Operation

The typical application circuit for the adjustable output regulators is shown in Figure 1. The adjustable device develops and maintains the nominal 0.9 V reference voltage between Adj and ground pins. A resistor divider network R1 and R2 causes a fixed current to flow to ground. This current creates a voltage across R1 that adds to the 0.9 V across R2 and sets the overall output voltage.

The output voltage is set according to the formula:

$$V_{\text{out}} = V_{\text{ref}} \times \left( \frac{R1 + R2}{R2} \right) - I_{\text{Adj}} \times R2$$

The adjust pin current,  $I_{\text{adj}}$ , is typically 30 nA and normally much lower than the current flowing through R1 and R2, thus it generates a small output voltage error that can usually be ignored.

#### Load Transient Measurement

Large load current changes are always presented in microprocessor applications. Therefore good load transient performance is required for the power stage. NCP565 has the feature of ultra fast transient response. Its load transient responses in Figures 11 through 14 are tested on evaluation board shown in Figure 18. On the evaluation board, it consists of NCP565 regulator circuit with decoupling and filter capacitors and the pulse controlled current sink to obtain load current transitions. The load current transitions are measured by current probe. Because the signal from current probe has some time delay, it causes un-synchronization between the load current transition and output voltage response, which is shown in Figures 11 through 14.

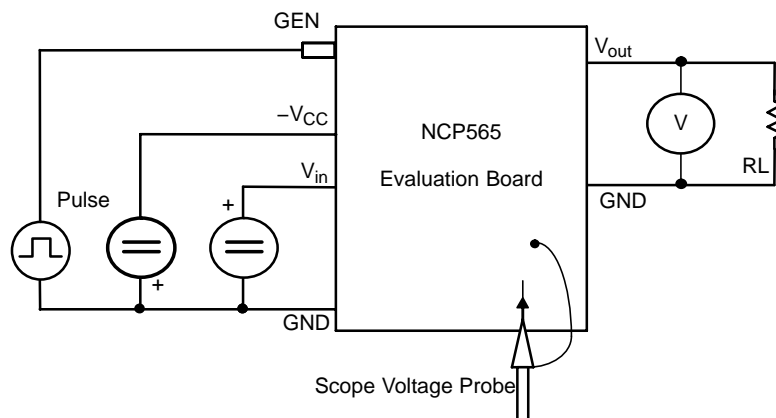

Figure 18. Schematic for Transient Response Measurement



## NCP565/NCV565

### PCB Layout Considerations

Good PCB layout plays an important role in achieving good load transient performance. Because it is very sensitive to its PCB layout, particular care has to be taken when tackling Printed Circuit Board (PCB) layout. The figures below give an example of a layout where parasitic elements are minimized. For microprocessor applications it is customary to use an output capacitor network consisting of

several capacitors in parallel. This reduces the overall ESR and reduces the instantaneous output voltage drop under transient load conditions. The output capacitor network should be as close as possible to the load for the best results. The schematic of NCP565 typical application circuit, which this PCB layout is based on, is shown in Figure 19. The output voltage is set to 3.3 V for this demonstration board according to the feedback resistors in the Table 1.

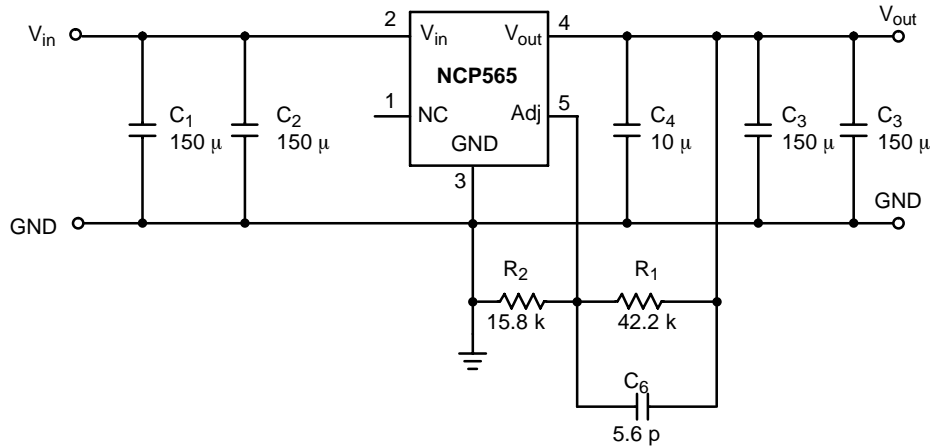

Figure 19. Schematic of NCP565 Typical Application Circuit

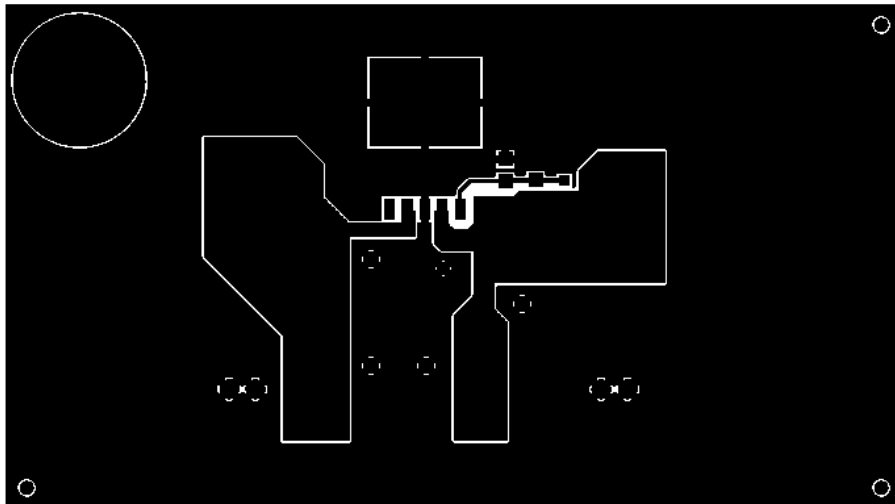
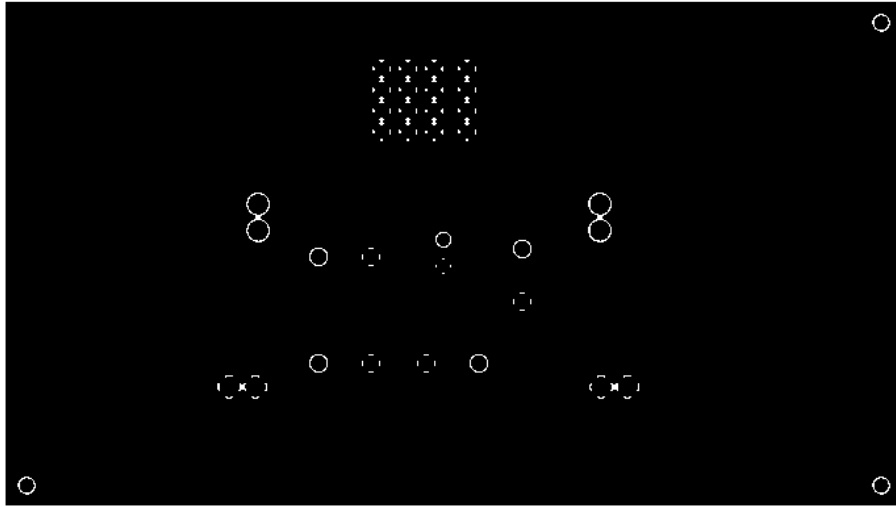
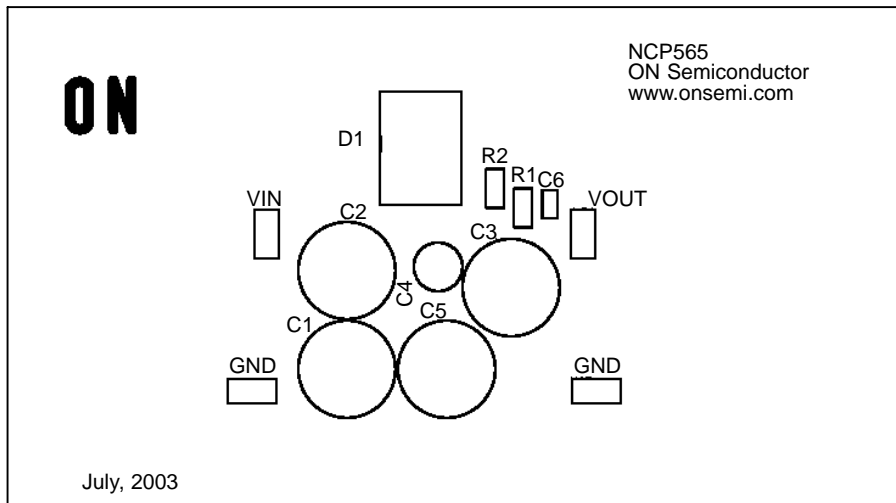

Figure 20. Top Layer

## NCP565/NCV565



**Figure 21. Bottom Layer**



**Figure 22. Silkscreen Layer**

**Table 1. Bill of Materials for NCP565 Adj Demonstration Board**

Item	Used #	Component	Designators	Suppliers	Part Number
1	4	Radial Lead Aluminum Capacitor 150 $\mu$ F/16 V	C1, C2, C3, C5	Sanyo Oscon	16SA150M
2	1	Radial Lead Aluminum Capacitor 10 $\mu$ F/10 V	C4	Sanyo Oscon	10SL10M
3	1	SMT Chip Resistor (0805) 15.8 K 1%	R2	Vishay	CRCW08051582F
4	1	SMT Chip Resistor (0805) 42.2 K 1%	R1	Vishay	CRCW08054222F
5	1	SMT Ceramic Capacitor (0603) 5.6 pF 10%	C6	Vishay	VJ0603A5R6KXAA
6	1	NCP565 Low Dropout Linear Regulator	U1	ON Semiconductor	NCP565D2TR4

## NCP565/NCV565

### Protection Diodes

When large external capacitors are used with a linear regulator it is sometimes necessary to add protection diodes. If the input voltage of the regulator gets shorted, the output capacitor will discharge into the output of the regulator. The discharge current depends on the value of the capacitor, the output voltage and the rate at which  $V_{in}$  drops. In the NCP565 linear regulator, the discharge path is through a large junction and protection diodes are not usually needed. If the regulator is used with large values of output capacitance and the input voltage is instantaneously shorted to ground, damage can occur. In this case, a diode connected as shown in Figure 23 is recommended.

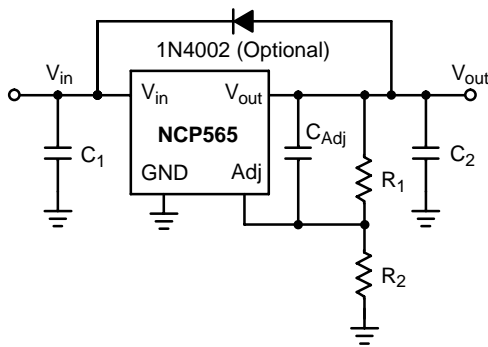
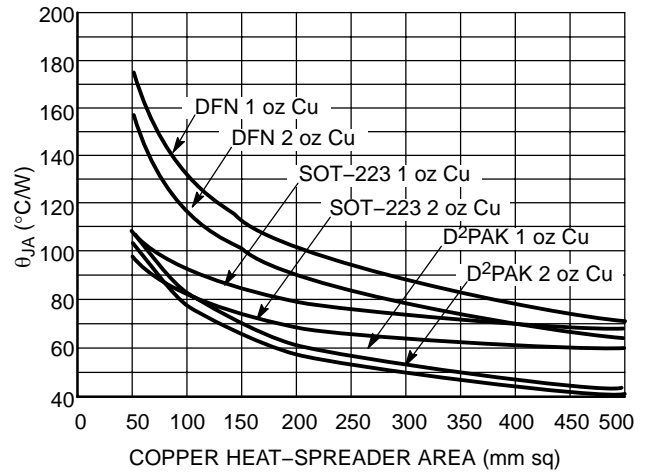

**Figure 23. Protection Diode for Large Output Capacitors**

### Thermal Considerations

This series contains an internal thermal limiting circuit that is designed to protect the regulator in the event that the maximum junction temperature is exceeded. This feature provides protection from a catastrophic device failure due to accidental overheating. It is not intended to be used as a substitute for proper heat sinking. The maximum device power dissipation can be calculated by:

$$P_D = \frac{T_{J(max)} - T_A}{R_{\theta JA}}$$



**Figure 24. Thermal Resistance**

## NCP565/NCV565

### ORDERING INFORMATION

Device	Nominal Output Voltage*	Package	Shipping†
NCP565D2T	Adj	D <sup>2</sup> PAK	50 Units / Tube
NCP565D2TG		D <sup>2</sup> PAK (Pb-Free)	
NCP565D2TR4		D <sup>2</sup> PAK	800 / Tape & Reel
NCP565D2TR4G		D <sup>2</sup> PAK (Pb-Free)	
NCP565MNADJT2G		DFN6 (Pb-Free)	3000 / Tape & Reel
NCP565D2T12	Fixed (1.2 V)	D <sup>2</sup> PAK	50 Units / Tube
NCP565D2T12G		D <sup>2</sup> PAK (Pb-Free)	
NCP565D2T12R4		D <sup>2</sup> PAK	800 / Tape & Reel
NCP565D2T12R4G		D <sup>2</sup> PAK (Pb-Free)	
NCP565MN12T2G		DFN6 (Pb-Free)	3000 / Tape & Reel
NCP565ST12T3G		SOT-223 (Pb-Free)	4000 / Tape & Reel
NCP565D2T33G	Fixed (3.3 V)	D <sup>2</sup> PAK (Pb-Free)	50 Units / Tube
NCP565D2T33R4G		D <sup>2</sup> PAK (Pb-Free)	800 / Tape & Reel
NCP565MN33T2G		DFN6 (Pb-Free)	3000 / Tape & Reel
NCV565D2TG	Adj	D <sup>2</sup> PAK (Pb-Free)	50 Units / Tube
NCV565D2TR4G			800 / Tape & Reel

\*For other fixed output versions, please contact the factory.

†For information on tape and reel specifications, including part orientation and tape sizes, please refer to our Tape and Reel Packaging Specifications Brochure, BRD8011/D.

# NCP565/NCV565

## PACKAGE DIMENSIONS

D<sup>2</sup>PAK-3  
D2T SUFFIX  
CASE 936-03  
ISSUE B

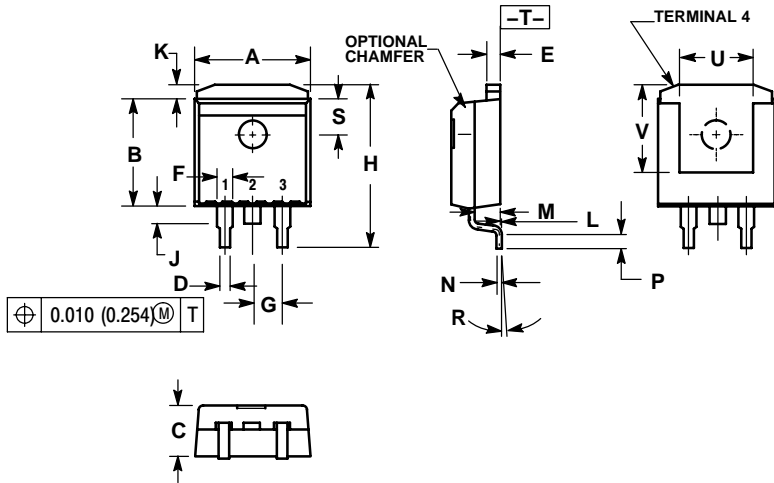

### NOTES:

1. DIMENSIONING AND TOLERANCING PER ANSI Y14.5M, 1982.
2. CONTROLLING DIMENSION: INCH.
3. TAB CONTOUR OPTIONAL WITHIN DIMENSIONS A AND K.
4. DIMENSIONS U AND V ESTABLISH A MINIMUM MOUNTING SURFACE FOR TERMINAL 4.
5. DIMENSIONS A AND B DO NOT INCLUDE MOLD FLASH OR GATE PROTRUSIONS. MOLD FLASH AND GATE PROTRUSIONS NOT TO EXCEED 0.025 (0.635) MAXIMUM.

DIM	INCHES		MILLIMETERS	
	MIN	MAX	MIN	MAX
A	0.386	0.403	9.804	10.236
B	0.356	0.368	9.042	9.347
C	0.170	0.180	4.318	4.572
D	0.026	0.036	0.660	0.914
E	0.045	0.055	1.143	1.397
F	0.051 REF		1.295 REF	
G	0.100 BSC		2.540 BSC	
H	0.539	0.579	13.691	14.707
J	0.125 MAX		3.175 MAX	
K	0.050 REF		1.270 REF	
L	0.000	0.010	0.000	0.254
M	0.088	0.102	2.235	2.591
N	0.018	0.026	0.457	0.660
P	0.058	0.078	1.473	1.981
R	5° REF		5° REF	
S	0.116 REF		2.946 REF	
U	0.200 MIN		5.080 MIN	
V	0.250 MIN		6.350 MIN	

### SOLDERING FOOTPRINT\*

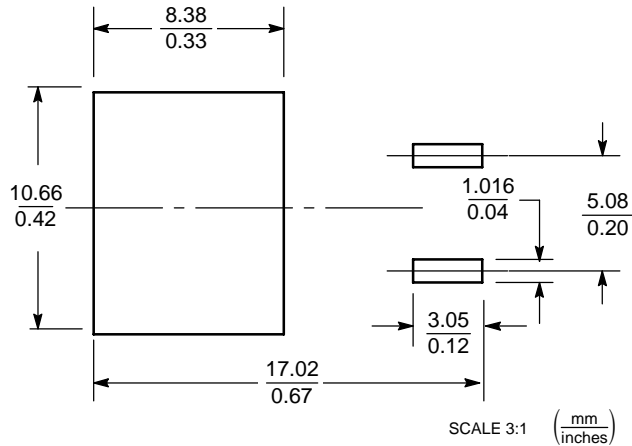

\*For additional information on our Pb-Free strategy and soldering details, please download the ON Semiconductor Soldering and Mounting Techniques Reference Manual, SOLDERRM/D.

# NCP565/NCV565

## PACKAGE DIMENSIONS

**D<sup>2</sup>PAK 5**  
CASE 936A-02  
ISSUE C

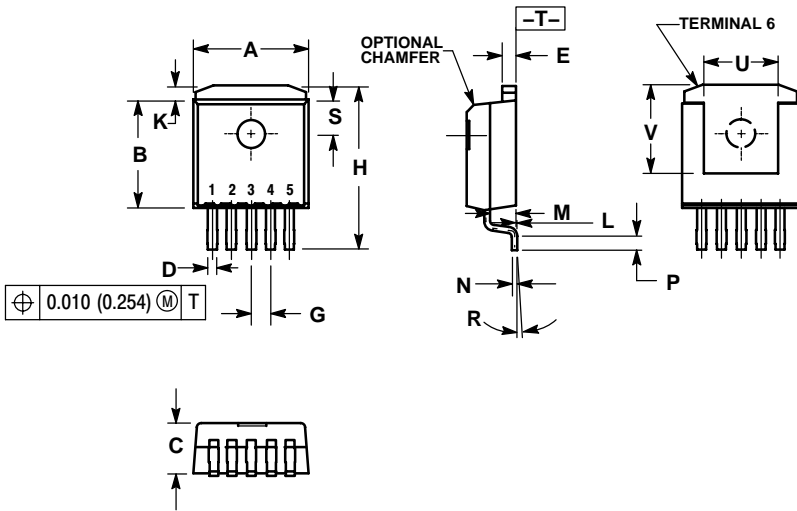

**NOTES:**

1. DIMENSIONING AND TOLERANCING PER ANSI Y14.5M, 1982.
2. CONTROLLING DIMENSION: INCH.
3. TAB CONTOUR OPTIONAL WITHIN DIMENSIONS A AND K.
4. DIMENSIONS U AND V ESTABLISH A MINIMUM MOUNTING SURFACE FOR TERMINAL 6.
5. DIMENSIONS A AND B DO NOT INCLUDE MOLD FLASH OR GATE PROTRUSIONS. MOLD FLASH AND GATE PROTRUSIONS NOT TO EXCEED 0.025 (0.635) MAXIMUM.

DIM	INCHES		MILLIMETERS	
	MIN	MAX	MIN	MAX
A	0.386	0.403	9.804	10.236
B	0.356	0.368	9.042	9.347
C	0.170	0.180	4.318	4.572
D	0.026	0.036	0.660	0.914
E	0.045	0.055	1.143	1.397
G	0.067 BSC		1.702 BSC	
H	0.539	0.579	13.691	14.707
K	0.050 REF		1.270 REF	
L	0.000	0.010	0.000	0.254
M	0.088	0.102	2.235	2.591
N	0.018	0.026	0.457	0.660
P	0.058	0.078	1.473	1.981
R	5° REF		5° REF	
S	0.116 REF		2.946 REF	
U	0.200 MIN		5.080 MIN	
V	0.250 MIN		6.350 MIN	

### SOLDERING FOOTPRINT\*

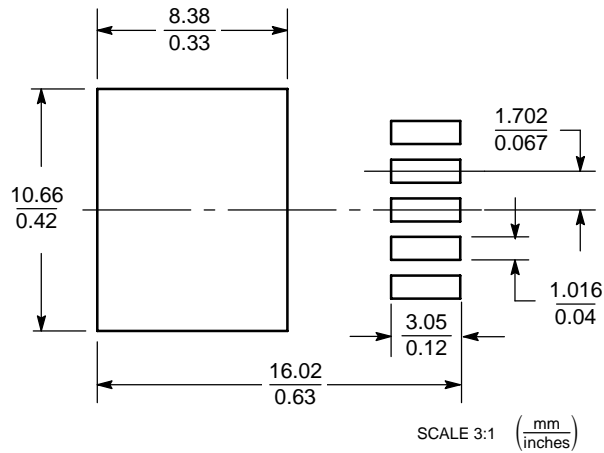

### 5-LEAD D<sup>2</sup>PAK

\*For additional information on our Pb-Free strategy and soldering details, please download the ON Semiconductor Soldering and Mounting Techniques Reference Manual, SOLDERRM/D.

# NCP565/NCV565

## PACKAGE DIMENSIONS

SOT-223 (TO-261)  
CASE 318E-04  
ISSUE L

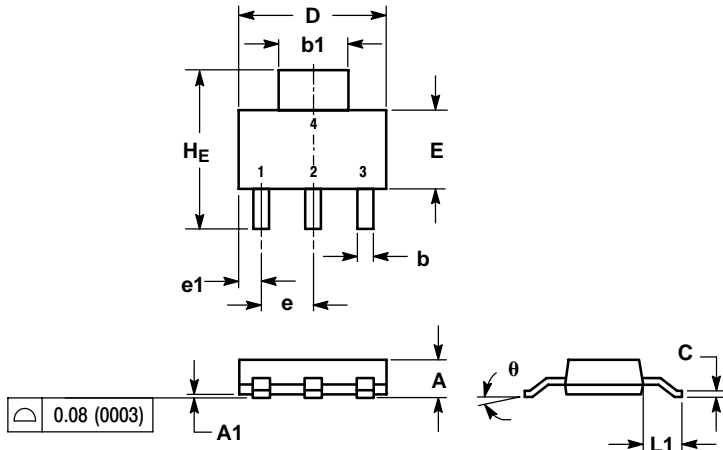

NOTES:  
6. DIMENSIONING AND TOLERANCING PER ANSI Y14.5M, 1982.  
7. CONTROLLING DIMENSION: INCH.

DIM	MILLIMETERS			INCHES		
	MIN	NOM	MAX	MIN	NOM	MAX
A	1.50	1.63	1.75	0.060	0.064	0.068
A1	0.02	0.06	0.10	0.001	0.002	0.004
b	0.60	0.75	0.89	0.024	0.030	0.035
b1	2.90	3.06	3.20	0.115	0.121	0.126
c	0.24	0.29	0.35	0.009	0.012	0.014
D	6.30	6.50	6.70	0.249	0.256	0.263
E	3.30	3.50	3.70	0.130	0.138	0.145
e	2.20	2.30	2.40	0.087	0.091	0.094
e1	0.85	0.94	1.05	0.033	0.037	0.041
L1	1.50	1.75	2.00	0.060	0.069	0.078
HE	6.70	7.00	7.30	0.264	0.276	0.287
θ	0°	-	10°	0°	-	10°

### SOLDERING FOOTPRINT\*

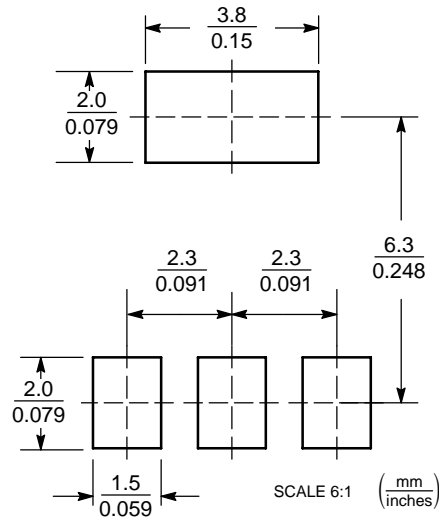

\*For additional information on our Pb-Free strategy and soldering details, please download the ON Semiconductor Soldering and Mounting Techniques Reference Manual, SOLDERRM/D.

# NCP565/NCV565

## PACKAGE DIMENSIONS

DFN6, 3x3.3, 0.95 PITCH  
CASE 506AX-01  
ISSUE O

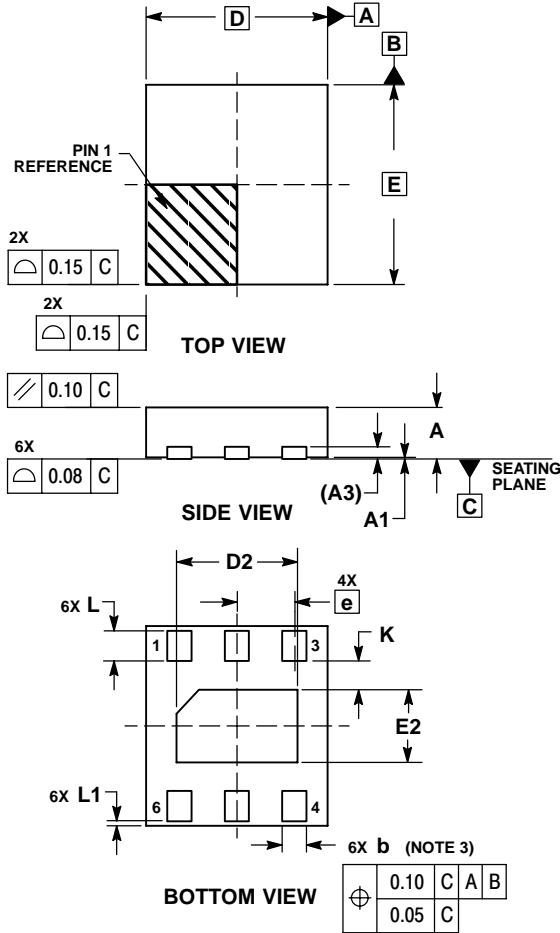

**NOTES:**

1. DIMENSIONS AND TOLERANCING PER ASME Y14.5M, 1994.
2. CONTROLLING DIMENSION: MILLIMETERS.
3. DIMENSION b APPLIES TO PLATED TERMINAL AND IS MEASURED BETWEEN 0.25 AND 0.30 mm FROM TERMINAL.
4. COPLANARITY APPLIES TO THE EXPOSED PAD AS WELL AS THE TERMINALS.

MILLIMETERS			
DIM	MIN	NOM	MAX
A	0.80	---	0.90
A1	0.00	---	0.05
A3	0.20 REF		
b	0.30	---	0.40
D	3.00 BSC		
D2	1.90	---	2.10
E	3.30 BSC		
E2	1.10	---	1.30
e	0.95 BSC		
K	0.20	---	---
L	0.40	---	0.60
L1	0.00	---	0.15

**SOLDERING FOOTPRINT\***

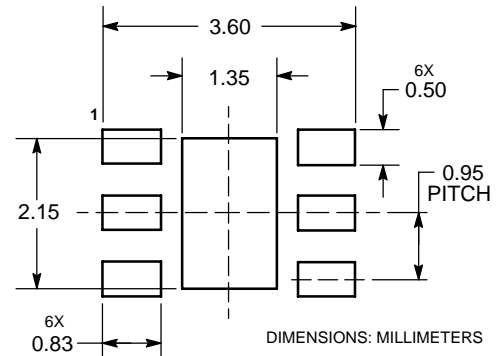

\*For additional information on our Pb-Free strategy and soldering details, please download the ON Semiconductor Soldering and Mounting Techniques Reference Manual, SOLDERRM/D.

The product described herein (NCP565), may be covered by one or more of the following U.S. patents: 5,920,184; 5,834,926. There may be other patents pending.

ON Semiconductor and are registered trademarks of Semiconductor Components Industries, LLC (SCILLC). SCILLC reserves the right to make changes without further notice to any products herein. SCILLC makes no warranty, representation or guarantee regarding the suitability of its products for any particular purpose, nor does SCILLC assume any liability arising out of the application or use of any product or circuit, and specifically disclaims any and all liability, including without limitation special, consequential or incidental damages. "Typical" parameters which may be provided in SCILLC data sheets and/or specifications can and do vary in different applications and actual performance may vary over time. All operating parameters, including "Typicals" must be validated for each customer application by customer's technical experts. SCILLC does not convey any license under its patent rights nor the rights of others. SCILLC products are not designed, intended, or authorized for use as components in systems intended for surgical implant into the body, or other applications intended to support or sustain life, or for any other application in which the failure of the SCILLC product could create a situation where personal injury or death may occur. Should Buyer purchase or use SCILLC products for any such unintended or unauthorized application, Buyer shall indemnify and hold SCILLC and its officers, employees, subsidiaries, affiliates, and distributors harmless against all claims, costs, damages, and expenses, and reasonable attorney fees arising out of, directly or indirectly, any claim of personal injury or death associated with such unintended or unauthorized use, even if such claim alleges that SCILLC was negligent regarding the design or manufacture of the part. SCILLC is an Equal Opportunity/Affirmative Action Employer. This literature is subject to all applicable copyright laws and is not for resale in any manner.

**PUBLICATION ORDERING INFORMATION**

**LITERATURE FULFILLMENT:**  
Literature Distribution Center for ON Semiconductor  
P.O. Box 5163, Denver, Colorado 80217 USA  
Phone: 303-675-2175 or 800-344-3860 Toll Free USA/Canada  
Fax: 303-675-2176 or 800-344-3867 Toll Free USA/Canada  
Email: orderlit@onsemi.com

**N. American Technical Support:** 800-282-9855 Toll Free USA/Canada  
**Europe, Middle East and Africa Technical Support:**  
Phone: 421 33 790 2910  
**Japan Customer Focus Center**  
Phone: 81-3-5773-3850

**ON Semiconductor Website:** [www.onsemi.com](http://www.onsemi.com)  
**Order Literature:** <http://www.onsemi.com/orderlit>  
For additional information, please contact your local Sales Representative