

**Huck
Fasteners**

From Cordant Technologies

NOSE ASSEMBLY DATA SHEET

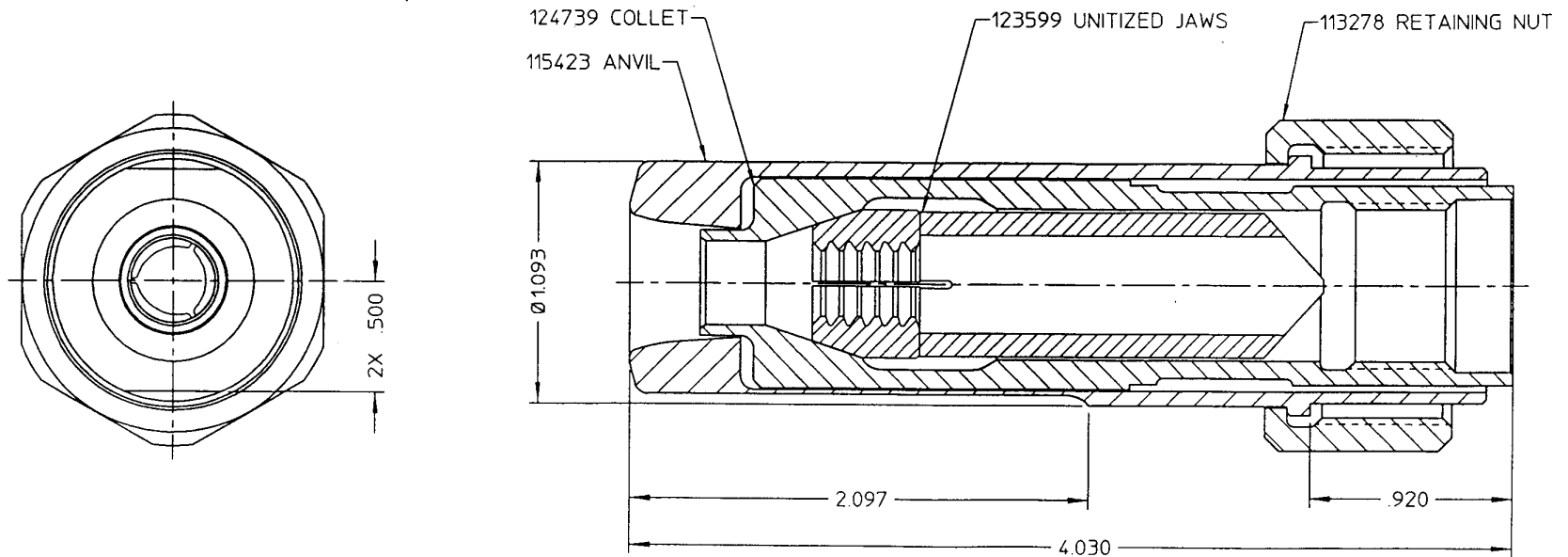

©Huck International, Inc. 1995
©Registered Trademark of Huck International, Inc., Irvine, CA
™Trademark of Huck International, Inc., Irvine, CA

** 245 2502
246 2503
247 2580

U.S. Patent No. 4,347,728

Chrome band on anvil of
MAGNA-GRIP® fasteners.

99-1440	Huck International, Inc. Installation System Division 1 Corporate Drive - Kingston, NY 12401	
	TYPE: Non Self-releasing FOR: MAGNA-GRIP HUCKBOLT -12 TOOL: **	
	OTHER	ISSUED: 10-95 REVISED:

Nose Assembly Maintenance

1. Prepare tool per manual. Remove any loose shims from spindle/rod with small pick.

WARNING: Before maintenance or adjustments, POWERIG Hydraulic Unit must be disconnected from electrical or air supply: air operated tools must be disconnected from air supply. If not disconnected, severe personal injury and/or damage may result.

2. Tools that use hydraulic source:

Connect tool's hoses and controls to POWERIG Hydraulic Unit. Reconnect power source. Depress trigger for 30 seconds. Disconnect controls and and **RETURN** hose - - **tool piston must be completely forward.**

Tools that use air source:

Air supply should have filter - regulator lubricator unit with regulator set at 90 psi (620 kPa). Cycle tool a few times and disconnect from air supply **with spindle/rod completely forward.**

Caution: In severe conditions, VIBRA-TITE can be used on collet and/or extension threads to prevent loosening and damage. Carefully follow container's directions.

3. Disassembly/assembly *as applicable*:

Remove parts of nose assembly for inspection and maintenance.

Collet; extension:

Assemble parts as shown - - apply thin coat of SUPER O-LUBE to O-Rings and OD of sleeve; VIBRA-TITE to extension W/O lock collar. See **Caution.** Thread collet/extension/adaptor onto spindle/rod. Use 5/16 hex key, 1/2 hex key, collet wrench, or other appropriate wrench - - tighten wrench-tight. Assemble collet to adaptor with split ring.

2580: to prevent piston from turning, hold 3/8 hex key in rear of tool.

Anvil; anvil holder:

Thread anvil insert into holder and tighten. Pressed-in anvil is pressed out with drift and arbor press. With arbor press, press new anvil in squarely to prevent cracking. Assemble anvil retainer to anvil. Align collet and anvil flats - - install button head screw with 1/8 hex key.

4. Attaching to tool *as applicable*:

Slide holder/anvil over collet. Position split ring on anvil; slide stop and retaining nut over holder/anvil -- tighten hand-tight.

5. **As applicable:** See **WARNING** - - connect controls and **RETURN** hose on hydraulic tool. Reconnect hydraulic unit or air tool/unit to power source. Install fasteners in test plate of correct thickness with proper size holes - inspect installed fasteners.

Notes:

1. *To increase Jaw life:* Disassemble nose assembly periodically; clean and inspect components- - use a pick to clean jaw grooves. **Caution:** Wash parts in **mineral spirits or isopropyl alcohol** only. Dry O-Rings; urethane jaw assemblies **immediately** after cleaning as prolonged contact with solvent causes swelling - dry other parts.

2. *Spare parts - - as required:* Jaws, press-in anvil, anvil insert, ratchet pin, spring, release/ejector assembly, screw - 120726 and anvil retainer.

3. *Tools/service items - - as required:* Brushes NYLON bristle - - 105805 (04, 05 & 06), 105806 (08); collet wrenches - - 502914 (9/16), 502920 (13/16); drifts - - 83097 (.434 wide), 79524 (.684 wide); adjustable wrench, 503044; 1/8 hex key, 502294; 5/16 hex key, 502446; 3/8 hex key, 502650; 1/2 hex key, 505899; Parker's SUPER OLUBE (for O-rings if used); VIBRA-TITE, 505125.

245/246/247/2502/2580 W/O lock collars; ears optional