

## 3-Phase Sensorless Fan Motor Driver

### DESCRIPTION

EUM6801 is a 3-phase sensorless fan motor driver. It senses the BEMF (Back Electromotive Force) of the motor in rotation and provides corresponding commutation current to the motor. The sensorless technology doesn't need Hall sensors. The absence of the Hall sensor makes the fabrication of the motor easier, especially suitable for ultra-small motors.

EUM6801 integrates PWM speed control, soft switching, lock protection, auto restart, fan tachometer and forward/reverse functions.

As applying 3-phase driver method, PWM mode controls fan speed by adjusting duty cycle of PWM signal. Internal soft switching function drives fan motor in low noise and low vibration ways. EUM6801 can drive motor from stop mode to rotation mode by adjusting the external capacitor between OSC pin and GND pin. If a motor is stalled by external force or obstacles, over-driving current may incur coil overheat and burning. To prevent motor from overheating, the lock protection circuit shuts down the internal power devices for a few seconds after the motor lock is detected. Then the auto restart circuit resumes to power up the internal power devices. If the lock still persists, EUM6801 shuts down power devices for another few seconds. The lock protection time is built-in and need no external components. During rotation, FG outputs signal which represents motor speed. The motor rotation direction is controlled by setting FR to high or low.

### FEATURES

- 3-Phase Sensorless Drive Function (No Hall Sensor Needed)
- Few External Components (3 CAP Only)
- Low Startup Voltage: <1.8V
- PWM Speed Control and Soft Switching
- 20 $\mu$ A Low Standby Current
- Built in FG Outputs
- Built in Thermal Protection
- UDFN Small Package with Thermal Pad (3mm $\times$ 3mm $\times$ 0.5mm for Small Fan)
- RoHS Compliant and 100% Lead (Pb)-Free Halogen-Free

### APPLICATIONS

- NB Fan, Low Noise Fan and Low Power Consumption Fan

### Application Circuit

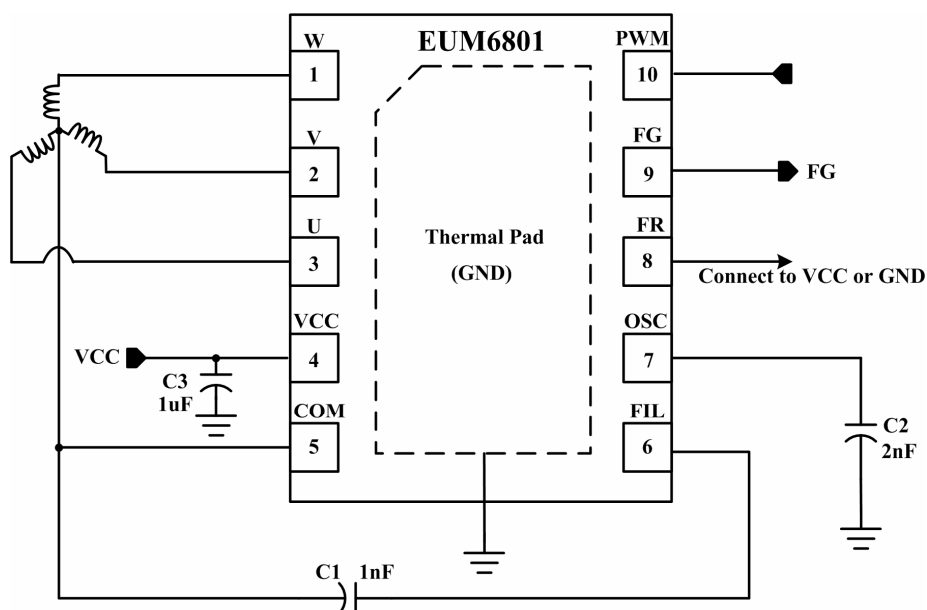

Figure 1.