



# 2SC3320

## NPN EPITAXIAL SILICON TRANSISTOR

### HIGH VOLTAGE HIGH SPEED SWITCHING

■ FEATURES

- \* High voltage, high speed switching
- \* High reliability

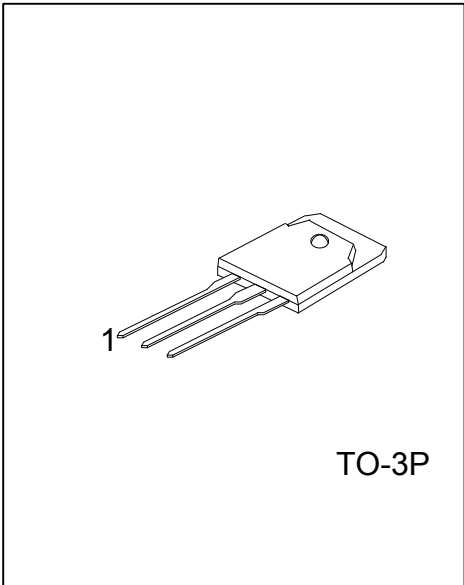

■ ORDERING INFORMATION

Ordering Number		Package	Pin Assignment			Packing
Lead Free	Halogen Free		1	2	3	
2SC3320L-x-T3P-T	2SC3320L-x-T3P-T	TO-3P	B	C	E	Tube

<p>2SC3320L-x-T3P-T</p>	<p>(1) Packing Type</p> <p>(2) Package Type</p> <p>(3) Rank</p> <p>(4) Lead Free</p>	<p>(1) T: Tube</p> <p>(2) T3P: TO-3P</p> <p>(3) x: refer to Classification of <math>h_{FE1}</math></p> <p>(4) G: Halogen Free, L: Lead Free</p>
-------------------------	--	---

### ■ ABSOLUTE MAXIMUM RATINGS (T<sub>c</sub> = 25°C)

PARAMETER	SYMBOL	RATINGS	UNIT
Collector Base Voltage	V <sub>CBO</sub>	500	V
Collector Emitter Voltage	V <sub>CEO</sub>	400	V
	V <sub>CEO(SUS)</sub>	400	V
Emitter Base Voltage	V <sub>EBO</sub>	7	V
Collector Current	I <sub>C</sub>	15	A
Base Current	I <sub>B</sub>	5	A
Power Dissipation	P <sub>D</sub>	80	W
Junction Temperature	T <sub>J</sub>	+150	°C
Storage Temperature	T <sub>STG</sub>	-40 ~ +150	°C

Note 1. Absolute maximum ratings are those values beyond which the device could be permanently damaged. Absolute maximum ratings are stress ratings only and functional device operation is not implied.

### ■ THERMAL DATA

PARAMETER	SYMBOL	RATINGS	UNIT
Junction to Case	θ <sub>JC</sub>	1.55	°C/W

### ■ ELECTRICAL SPECIFICATIONS (T<sub>c</sub>=25°C, Unless Otherwise Specified.)

PARAMETER	SYMBOL	TEST CONDITIONS	MIN	TYP	MAX	UNIT
Collector Base Voltage	V <sub>CBO</sub>	I <sub>CBO</sub> =1mA	500			V
Collector Emitter Voltage	V <sub>CEO</sub>	I <sub>CEO</sub> =10mA	400			V
	V <sub>CEO(SUS)</sub>	I <sub>C</sub> =0.2A	400			V
Emitter Base Voltage	V <sub>EBO</sub>	I <sub>EBO</sub> =1mA	7			V
Collector Emitter Saturation Voltage	V <sub>CE(SAT)</sub>	I <sub>C</sub> =6A, I <sub>B</sub> =1.2A			1	V
Base Emitter Saturation Voltage	V <sub>BE(SAT)</sub>				1.5	V
Collector Cut-off Current	I <sub>CBO</sub>	V <sub>CBO</sub> =500V			1	mA
Emitter Cut-off Current	I <sub>EBO</sub>	V <sub>EBO</sub> =7V			1	mA
DC Current Gain	h <sub>FE</sub>	I <sub>C</sub> =6A, V <sub>CE</sub> =5V	10		45	
Switching Time	t <sub>ON</sub>	I <sub>C</sub> =7.5A, I <sub>B1</sub> =1.5A, I <sub>B2</sub> =-3A R <sub>L</sub> =20Ω, P <sub>w</sub> =20μs, Duty ≤ 2%			0.5	μs
	t <sub>STG</sub>				1.5	μs
	t <sub>F</sub>				0.15	μs

### ■ CLASSIFICATION OF h<sub>FE</sub>

RANK	A	B	C	D	E	F
RANGE	10~15	15~20	20~25	25~30	30~35	35~45

■ SWITCHING TIME TEST CIRCUIT

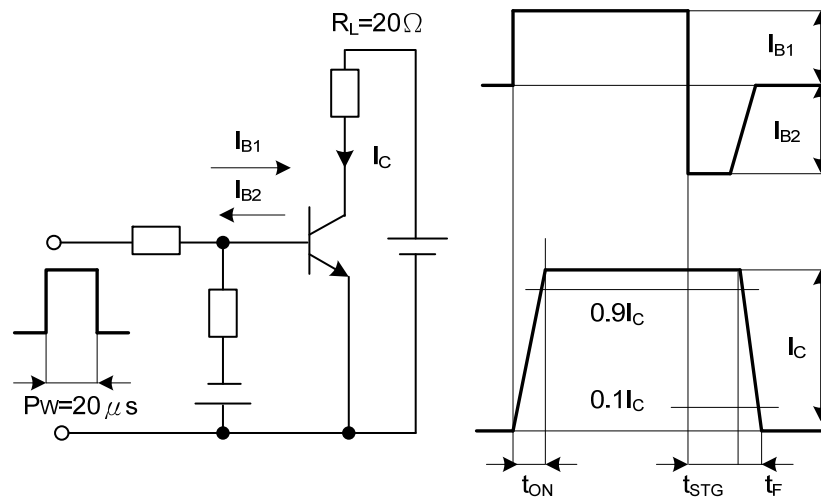

## TYPICAL CHARACTERISTICS

Collector Output Characteristics

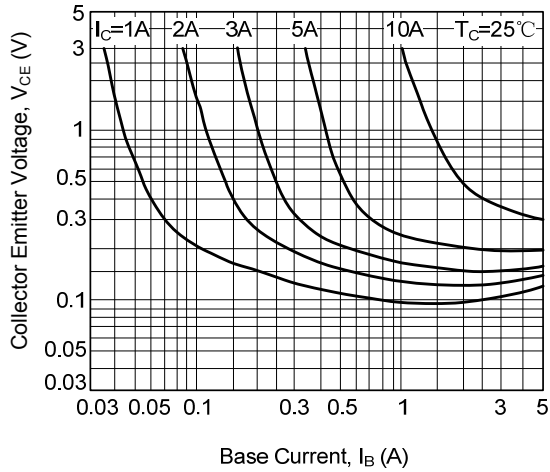

DC Current Gain

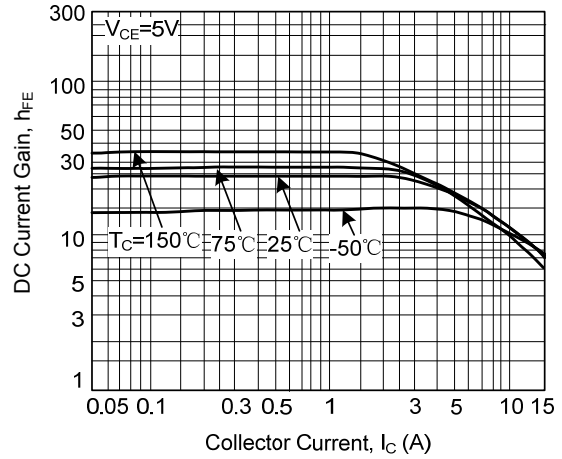

Base and Collector Saturation Voltage

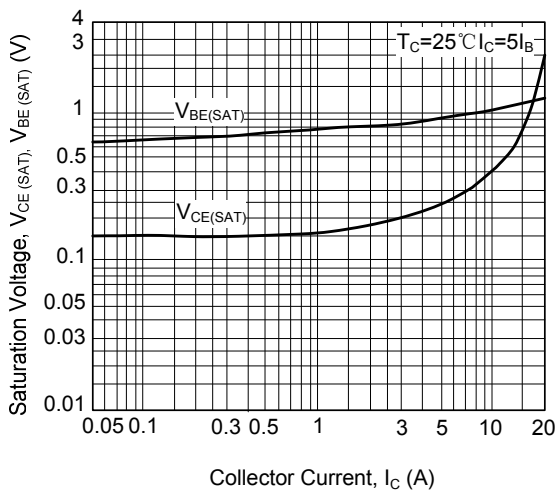

Safe Operating Area

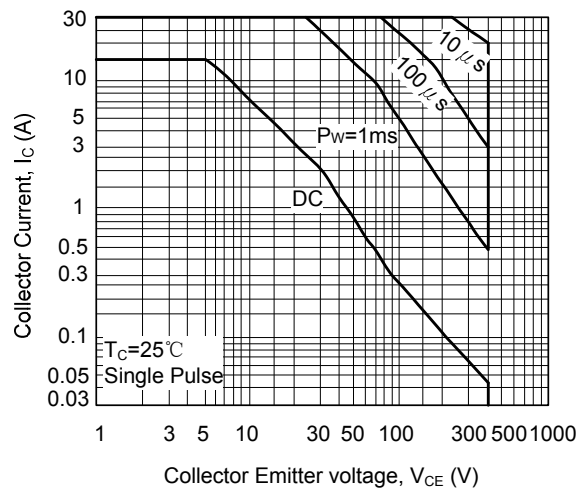

Switching Time

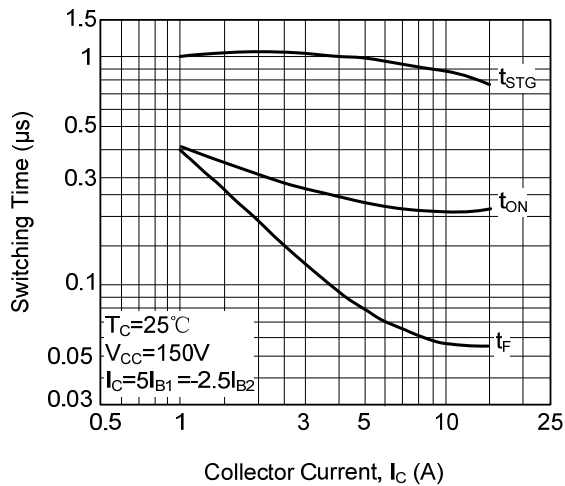

UTC assumes no responsibility for equipment failures that result from using products at values that exceed, even momentarily, rated values (such as maximum ratings, operating condition ranges, or other parameters) listed in products specifications of any and all UTC products described or contained herein. UTC products are not designed for use in life support appliances, devices or systems where malfunction of these products can be reasonably expected to result in personal injury. Reproduction in whole or in part is prohibited without the prior written consent of the copyright owner. The information presented in this document does not form part of any quotation or contract, is believed to be accurate and reliable and may be changed without notice.