



UC4601

Preliminary

CMOS IC

PWM STEP-DOWN DC-DC CONTROLLER

DESCRIPTION

The UTC UC4601 is a PWM step-down DC/DC controller. It has a low supply current. The step-down DC/DC converter with low ripple, high efficiency performance is conveniently configured with additional external components, such as a power-transistor, an inductor, a diode and capacitors. The output voltage can be adjusted with external components.

The UTC UC4601 contains a high precision band-gap voltage reference, a PWM control circuit, a soft-start circuit, a protection circuit, an oscillator, an error amplifier with built-in compensation network and input/output voltage detection circuits.

The UTC UC4601 based DC/DC converter can performance well when maintaining stability, which is due to its built-in state-of-art control algorithm. Further, if the term of maximum duty cycle retains on a certain time, the embedded protection circuits restart the operation with soft-start and repeat until the maximum duty cycle condition is released. Finally, the internal UVLO function blocks potentially unstable output when the input voltage reaches the UVLO threshold or less. This is aiming at making this circuit standby for low power consumption.

The UTC UC4601 can be applied in battery-powered equipment, hand-held communication equipment, cameras, video instruments such as VCRs, camcorders, household electrical appliances.

FEATURES

- * 500kHz oscillation frequency
- * Input voltage varies from 2.3V to 18V
- * Low temperature coefficient of output voltage: Typ. ±100ppm/°C
- * Internal soft-start and protection function
- * High efficiency up to 90% (TYP.)
- * High output voltage accuracy: ±2%
- * Standby current: 0.1µA (TYP.)
- * CMOS output capability

ORDERING INFORMATION

Ordering Number		Package	Packing
Lead Free	Halogen Free		
UC4601L-AF5-R	UC4601G-AF5-R	SOT-25	Tape Reel

<p>UC4601L - AF5 - R</p> <ul style="list-style-type: none"> (1) Packing Type (2) Package Type (3) Lead Free 	<ul style="list-style-type: none"> (1) R: Tape Reel (2) AF5: SOT-25 (3) G: Halogen Free, L: Lead Free
--	--

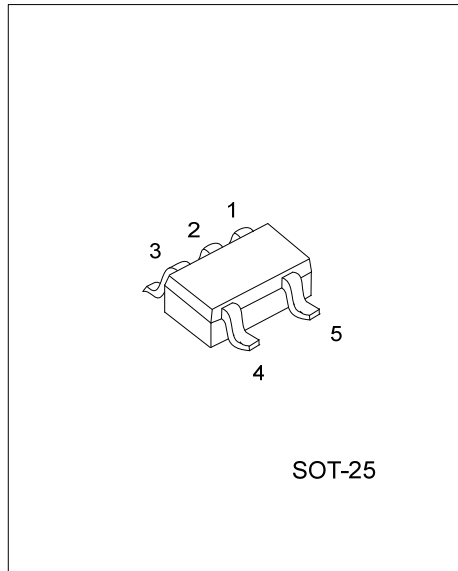

■ MARKING

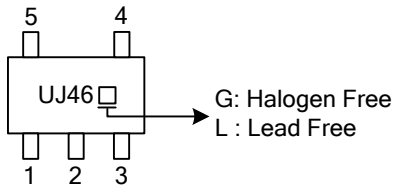

■ PIN CONFIGURATION

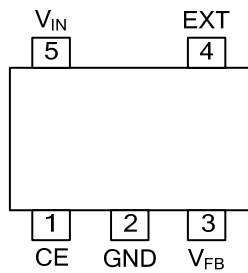

■ PIN DESCRIPTION

PIN NO	PIN NAME	DESCRIPTION
1	CE	Chip Enable. Active with "H"
2	GND	Ground
3	V_{FB}	Feedback Voltage
4	EXT	External Transistor Driver Pin (CMOS output)
5	V_{IN}	Power input voltage

■ ABSOLUTE MAXIMUM RATING

PARAMETER	SYMBOL	RATINGS	UNIT
V _{IN} Supply Voltage	V _{IN}	20	V
Ext Pin Output Voltage	V _{EXT}	-0.3 ~ V _{IN} +0.3	V
CE Pin Input Voltage	V _{CE}	-0.3 ~ V _{IN} +0.3	V
V _{OUT} /V _{FB} Pin Input Voltage	V _{OUT} /V _{FB}	-0.3 ~ 6	V
Ext Pin Output Current	I _{EXT}	±50	mA
Power Dissipation	P _D	+250	mW
Operating Temperature	T _{OPR}	-40 ~ +85	°C
Storage Temperature	T _{STG}	-55 ~ +125	°C

Note: Absolute maximum ratings are those values beyond which the device could be permanently damaged.

Absolute maximum ratings are stress ratings only and functional device operation is not implied.

■ OPERATING RANGE

PARAMETER	SYMBOL	RATINGS	UNIT
V _{IN} Supply Voltage	V _{IN}	2.5 ~ 18	V
Ext Pin Output Voltage	V _{EXT}	-0.3 ~ V _{IN} +0.3	V
CE Pin Input Voltage	V _{CE}	-0.3 ~ V _{IN} +0.3	V
V _{OUT} /V _{FB} Pin Input Voltage	V _{OUT} /V _{FB}	-0.3 ~ 5.5	V
Ext Pin Output Current	I _{EXT}	±50	mA

■ ELECTRICAL CHARACTERISTICS (T_{OPR}=25°C, unless otherwise specified)

PARAMETER	SYMBOL	TEST CONDITIONS	MIN	TYP	MAX	UNIT
ADJUSTABLE OUTPUT VOLTAGE TYPE						
Operating Voltage	V _{IN}		2.3		18	V
Feedback Voltage	V _{FB}	V _{IN} =V _{CE} =8V, I _{LOAD} =350mA	0.98	1.00	1.02	V
Feedback Voltage Temperature coefficient	ΔV _{FB} /ΔT	-40°C < T _{OPR} < 85°C		±100		ppm/°C
Supply Current	I _{Q1}	V _{IN} =V _{CE} =18V, V _{FB} =2V		40	80	μA
Shutdown Current	I _{Q2}	V _{IN} =18V, V _{CE} =V _{FB} =0V		0.1	1	μA
Oscillator Frequency	f _{OSC}	V _{IN} =V _{CE} =8V, I _{LOAD} =350mA	400	500	600	kHz
Maximum Duty Cycle	D _{MAX}		100			%
Minimum Duty Cycle	D _{MIN}				0	%
EXT "H" Output Current	I _{EXTH}	V _{IN} =V _{CE} =8V, V _{EXT} =7.9V, V _{FB} =3V		-17	-10	mA
EXT "L" Output Current	I _{EXTL}	V _{IN} =V _{CE} =8V, V _{EXT} =0.1V, V _{FB} =0V	20	30		mA
CE "H" Output Current	I _{CEH}	V _{IN} =V _{CE} =V _{OUT} =18V		0	0.5	μA
CE "L" Output Current	I _{CEL}	V _{IN} =V _{OUT} =18V, V _{CE} =0V	-0.3	0		μA
CE "H" Input Voltage	V _{CEH}	V _{IN} =8V, V _{FB} =0V	1.8			V
CE "L" Input Voltage	V _{CEL}	V _{IN} =8V, V _{FB} =0V			0.3	V
UVLO Voltage	V _{UVLO1}	V _{IN} =V _{CE} =2.5V≥1.5V, V _{FB} =0V	1.75	2.0	2.25	V
UVLO Release Voltage	V _{UVLO2}	V _{IN} =V _{CE} =1.5V≥2.5V, V _{FB} =0V		V _{UVLO1} +0.1	2.4	V
Delay Time by Soft-Start	T _{SST}	V _{IN} =8V, I _{LOAD} =10mA, V _{CE} =0V≥2.5V	5	10	20	ms
Delay Time by Protection	T _{PROT}	V _{IN} =V _{CE} =2.5V, V _{FB} =2.5V≥0V	5	15	30	ms

■ TYPICAL APPLICATION CIRCUIT

Adjustable Output Voltage Type. For example, Output Voltage=3.3V

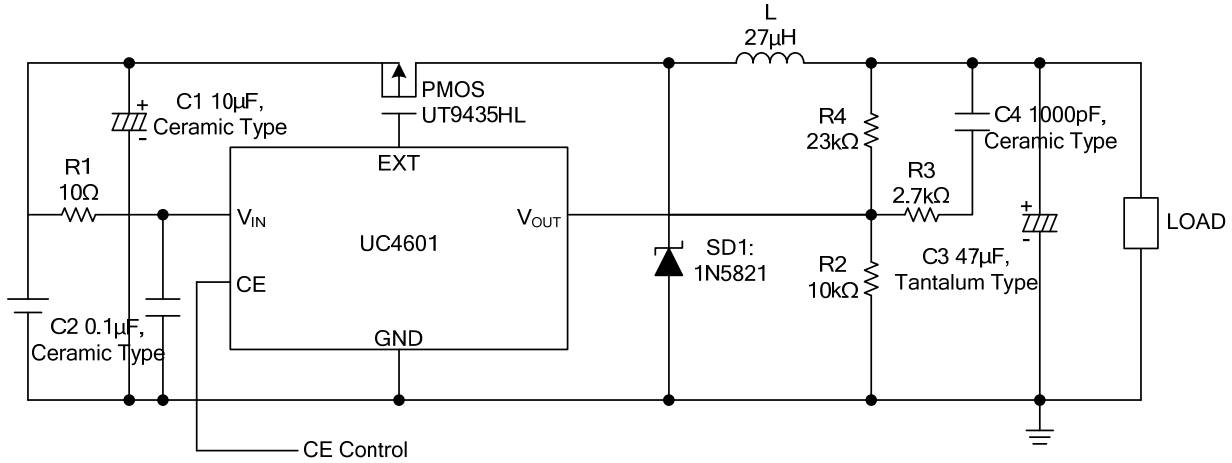

UTC assumes no responsibility for equipment failures that result from using products at values that exceed, even momentarily, rated values (such as maximum ratings, operating condition ranges, or other parameters) listed in products specifications of any and all UTC products described or contained herein. UTC products are not designed for use in life support appliances, devices or systems where malfunction of these products can be reasonably expected to result in personal injury. Reproduction in whole or in part is prohibited without the prior written consent of the copyright owner. The information presented in this document does not form part of any quotation or contract, is believed to be accurate and reliable and may be changed without notice.