

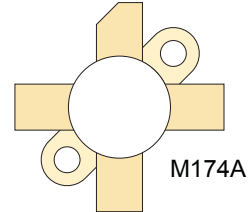

RF POWER VERTICAL MOSFET

The VRF151E is a thermally-enhanced version of the VRF151. It is a gold-metallized silicon n-channel RF power transistor designed for broadband commercial and military applications requiring high power and gain without compromising reliability, ruggedness, or inter-modulation distortion.



FEATURES

- Enhanced Package for 30% higher P_D
- Improved Ruggedness $V_{(BR)DSS} = 170V$
- 150W with 22dB Typical Gain @ 30MHz, 50V
- 150W with 14dB Typical Gain @ 175MHz, 50V
- Excellent Stability & Low IMD
- 30:1 Load VSWR Capability at Specified Operating Conditions
- Nitride Passivated
- Refractory Gold Metallization
- Replacement for SD2931-10 w/higher BV
- RoHS Compliant 

Maximum Ratings

All Ratings: $T_c = 25^\circ C$ unless otherwise specified

Symbol	Parameter	VRF151E	Unit
V_{DSS}	Drain-Source Voltage	170	V
I_D	Continuous Drain Current @ $T_c = 25^\circ C$	16	A
V_{GS}	Gate-Source Voltage	± 40	V
P_D	Total Device dissipation @ $T_c = 25^\circ C$	390	W
T_{STG}	Storage Temperature Range	-65 to 150	°C
T_J	Operating Junction Temperature	200	

Static Electrical Characteristics

Symbol	Parameter	Min	Typ	Max	Unit
$V_{(BR)DSS}$	Drain-Source Breakdown Voltage ($V_{GS} = 0V, I_D = 100mA$)	170	180		V
$V_{DS(ON)}$	On State Drain Voltage ($I_{D(ON)} = 10A, V_{GS} = 10V$)		2.0	3.0	
I_{DSS}	Zero Gate Voltage Drain Current ($V_{DS} = 100V, V_{GS} = 0V$)			1	mA
I_{GSS}	Gate-Source Leakage Current ($V_{DS} = \pm 20V, V_{GS} = 0V$)			1.0	μA
g_{fs}	Forward Transconductance ($V_{DS} = 10V, I_D = 5A$)	5.0			mhos
$V_{GS(TH)}$	Gate Threshold Voltage ($V_{DS} = 10V, I_D = 100mA$)	2.9	3.6	4.4	V

Thermal Characteristics

Symbol	Characteristic	Min	Typ	Max	Unit
$R_{\theta JC}$	Junction to Case Thermal Resistance			0.45	°C/W

 **CAUTION:** These Devices are Sensitive to Electrostatic Discharge. Proper Handling Procedures Should Be Followed.

Dynamic Characteristics

VRF151E

Symbol	Parameter	Test Conditions	Min	Typ	Max	Unit
C_{iss}	Input Capacitance	$V_{GS} = 0V$ $V_{DS} = 150V$ $f = 1MHz$		375		pF
C_{oss}	Output Capacitance			200		
C_{rss}	Reverse Transfer Capacitance			12		

Functional Characteristics

Symbol	Parameter	Min	Typ	Max	Unit
G_{PS}	$f_1 = 30MHz, f_2 = 30.001MHz, V_{DD} = 50V, I_{DQ} = 250mA, P_{out} = 150W_{PEP}$	18	22		dB
G_{PS}	$f = 175MHz, V_{DD} = 50V, I_{DQ} = 250mA, P_{out} = 150W$		14		
η_D	$f_1 = 30MHz, f_2 = 30.001MHz, V_{DD} = 50V, I_{DQ} = 250mA, P_{out} = 150W_{PEP}$		50		%
IMD _(d3)	$f_1 = 30MHz, f_2 = 30.001MHz, V_{DD} = 50V, I_{DQ} = 250mA, P_{out} = 150W_{PEP}^1$		-30		dBc
IMD _(d11)	$f_1 = 30MHz, f_2 = 30.001MHz, V_{DD} = 50V, I_{DQ} = 250mA, P_{out} = 150W_{PEP}$		-60		
Ψ	$f_1 = 30MHz, f_2 = 30.001MHz, V_{DD} = 50V, I_{DQ} = 250mA, P_{out} = 150W_{PEP}$ 30:1 VSWR - All Phase Angles	No Degradation in Output Power			

Class A Characteristics

Symbol	Test Conditions	Min	Typ	Max	Unit
G_{PS}	$f = 30MHz, V_{DD} = 50V, I_{DQ} = 250mA, P_{out} = 150W_{PEP}$		20		dB
IMD _(d3)	$f = 30MHz, V_{DD} = 50V, I_{DQ}(Max) = 3.75A, P_{out} = 150W_{PEP}$		-50		
IMD _(d9-d13)	$f = 30MHz, V_{DD} = 50V, I_{DQ} = 250mA, P_{out} = 150W_{PEP}$		-75		

1. To MIL-STD-1311 Version A, test method 2204B, Two Tone, Reference Each Tone

Microsemi reserves the right to change, without notice, the specifications and information contained herein.

Typical Performance Curves

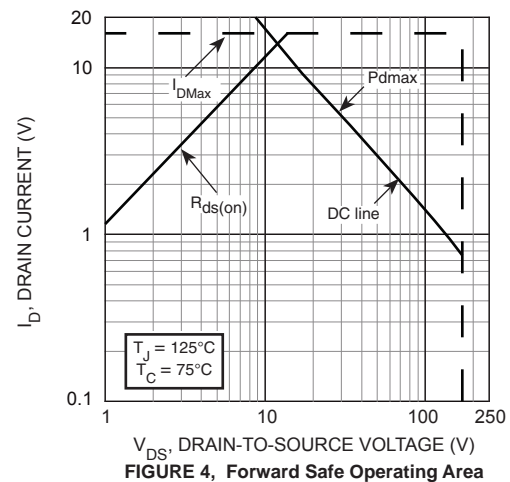
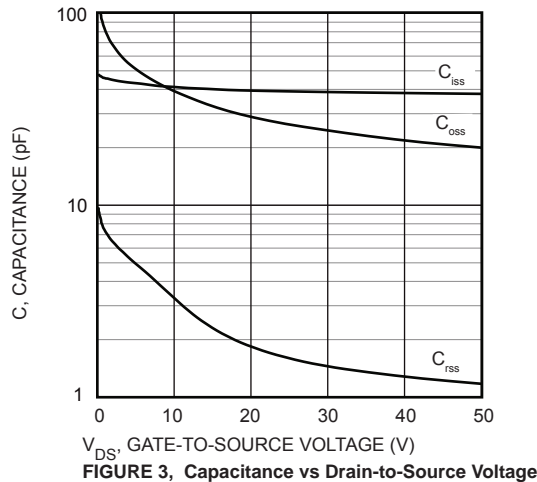
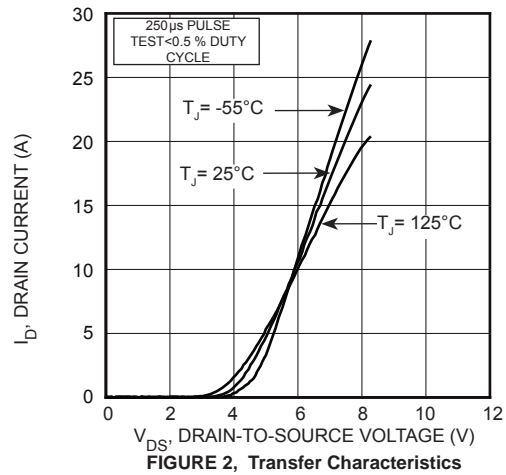
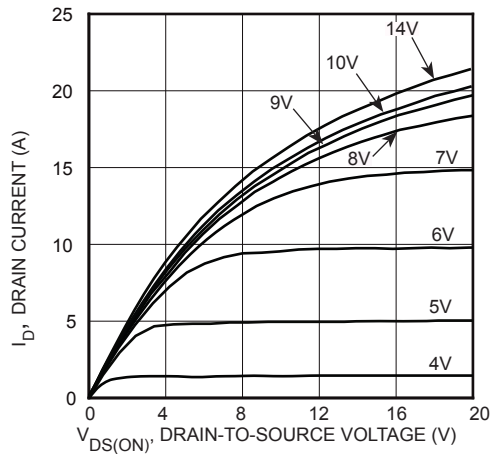

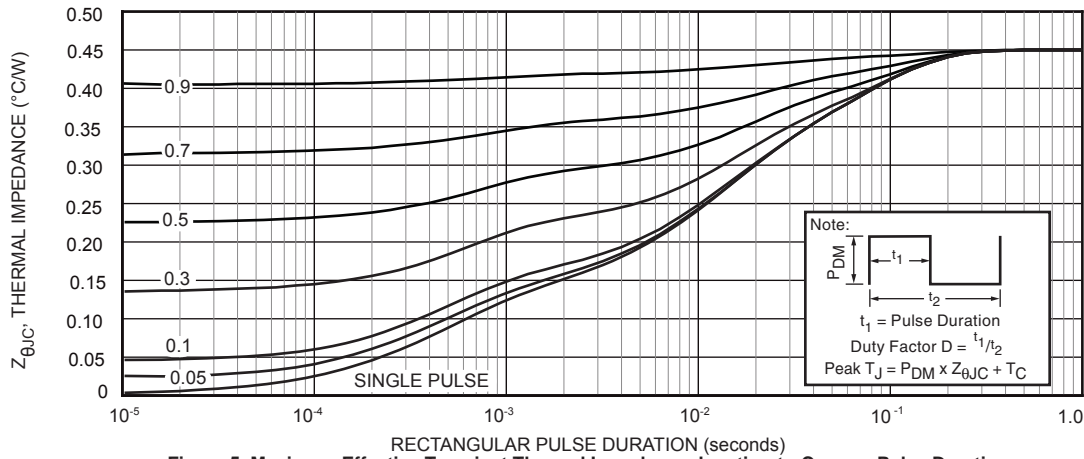

Figure 5. Maximum Effective Transient Thermal Impedance Junction-to-Case vs Pulse Duration

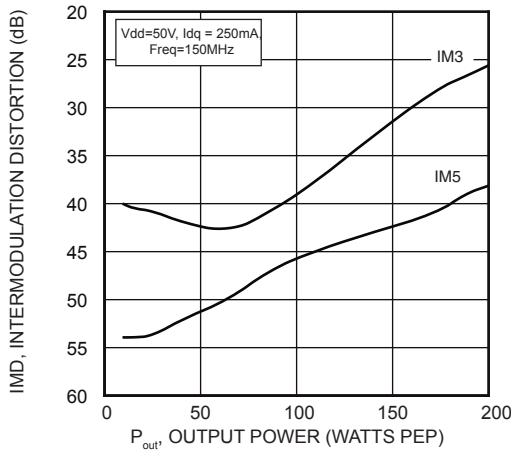

Figure 6. IMD versus P_{OUT}

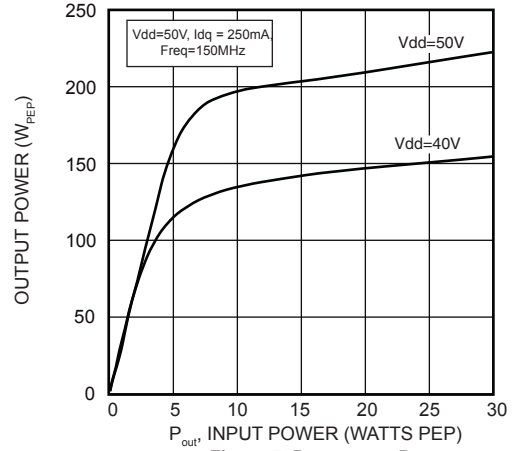
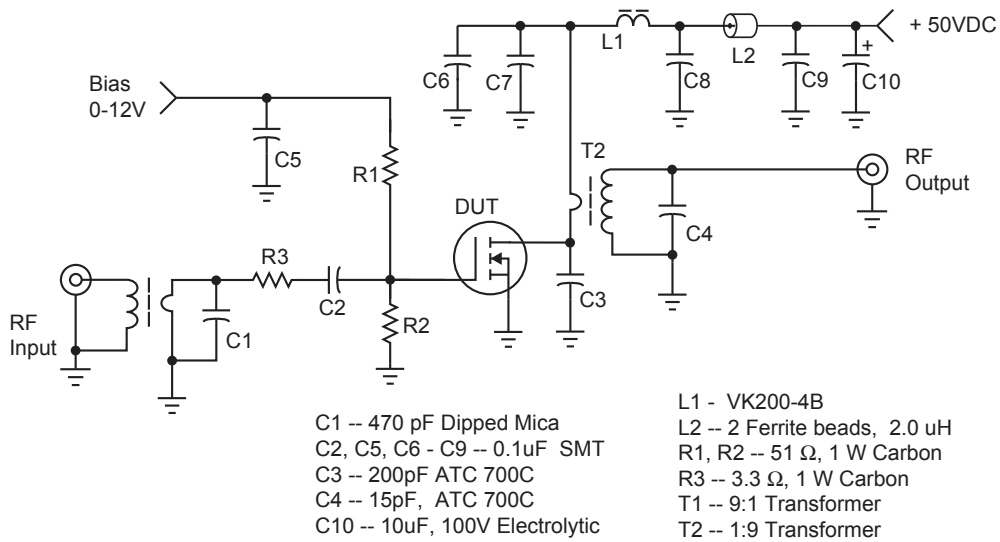
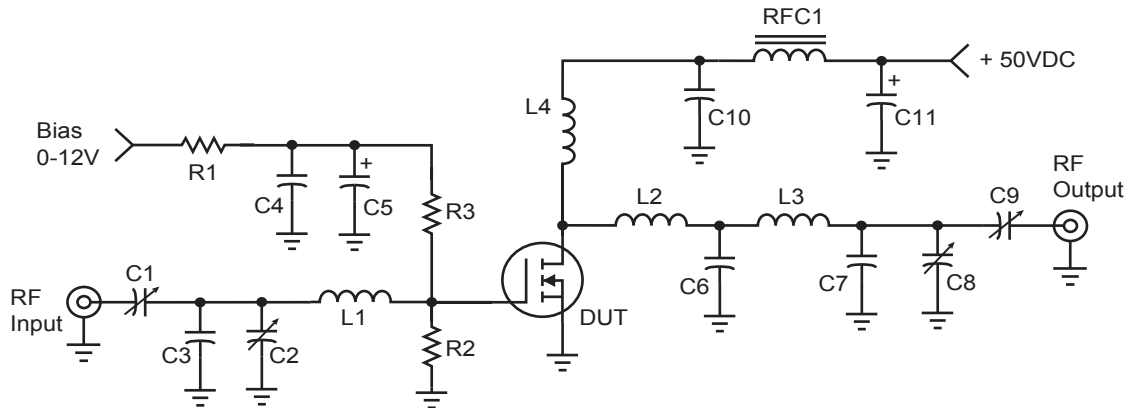

Figure 7. P_{OUT} versus P_{IN}

30 MHz test Circuit



175 MHz test Circuit



C1, C2, C8 -- Arco 463 or equivalent
 C3 -- 25pF, Unelco
 C4 -- 0.1uF, Ceramic
 C5 -- 1.0 uF, 15 WV Tantalum
 C6 -- 250pF, Unelco J101
 C7-- 25pF, Unelco J101
 C9 -- Arco 262 or equivalent
 C10 -- 0.05uF, Ceramic
 C11 -- 15uF, 60WV Electrolytic

L1 -- 3/4", #18 into Hairpin
 L2 -- Printed Line, 0.200" W x 0.500" L
 L3 -- 1", #16 into Hairpin approx 16nH
 L4 -- 2 turns #16, 5/16" ID
 RFC1 - VK200-4B
 R1 -- 150 Ω, 1/2W Carbon
 R2 -- 10k Ω, 1/2W Carbon
 R3 -- 120 Ω, 1/2W Carbon

.5" SOE Package Outline
All Dimensions are ± .005

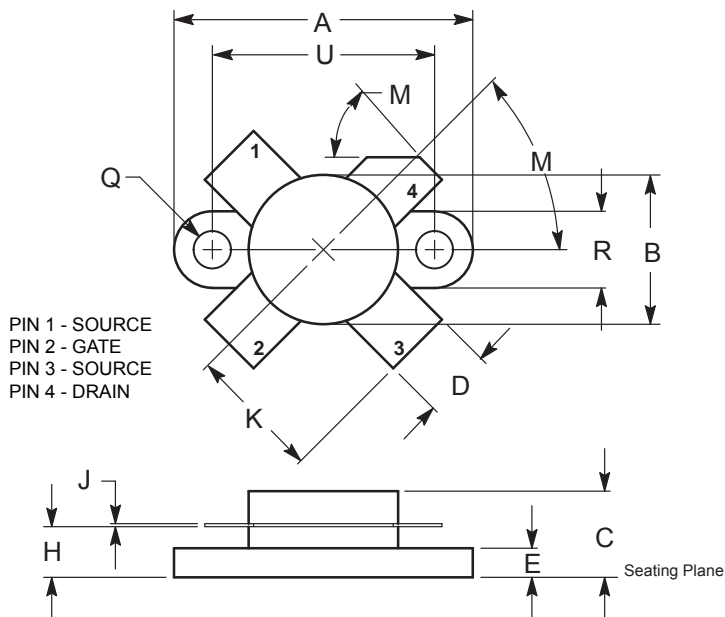

DIM	INCHES		MILLIMETERS	
	MIN	MAX	MIN	MAX
A	0.096	0.990	24.39	25.14
B	0.465	0.510	11.82	12.95
C	0.229	0.275	5.82	6.98
D	0.216	0.235	5.49	5.96
E	0.084	0.110	2.14	2.79
H	0.144	0.178	3.66	4.52
J	0.003	0.007	0.08	0.17
K	0.435		11.0	
M	45° NOM		45° NOM	
Q	0.115	0.130	2.93	3.30
R	0.246	0.255	6.25	6.47
U	0.720	0.730	18.29	18.54

Microsemi's products are covered by one or more of U.S. patents 4,895,810 5,045,903 5,089,434 5,182,234 5,019,522 5,262,336 6,503,786 5,256,583 4,748,103 5,283,202 5,231,474 5,434,095 5,528,058 6,939,743, 7,352,045 5,283,201 5,801,417 5,648,283 7,196,634 6,664,594 7,157,886 6,939,743 7,342,262 and foreign patents. US and Foreign patents pending. All Rights Reserved.