

MAXIM

MAX4447 Evaluation Kit

General Description

The MAX4447 evaluation kit (EV kit) simplifies evaluation of the MAX4447 high-speed differential line driver. The EV kit includes the MAX4447, which has a fixed gain of +2V/V, but it can also be used to evaluate the adjustable-gain MAX4448 (stable with a minimum gain of +2V/V) or the MAX4449 (stable with a minimum gain of +5V/V). To evaluate the MAX4448 or MAX4449, order a free sample of the MAX4448ESE or MAX4449ESE along with the MAX4447 EV kit.

Component List

DESIGNATION	QTY	DESCRIPTION
C1, C3	2	4.7 μ F \pm 20%, 10V tantalum capacitors AVX TAJA475M010R
C2, C4	2	0.1 μ F ceramic capacitors
R1, R2, R3	3	49.9 Ω \pm 1% resistors
RG	0	Not installed
JU1	1	2-pin header
None	1	Shunt (JU1)
IN, OUT-, OUT+	3	SMA connectors
U1	1	MAX4447ESE
None	1	MAX4447 EV kit PC board
None	1	MAX4447 EV kit data sheet
None	1	MAX4447/MAX4448/MAX4449 data sheet

Component Suppliers

SUPPLIER	PHONE	FAX
AVX	803-946-0690	803-626-3123

Note: Please indicate that you are using the MAX4447, MAX4448, or MAX4449 when contacting the component supplier above.

Features

- ◆ 430MHz Full-Power Bandwidth (MAX4447)
- ◆ 6500V/ μ s Slew Rate
- ◆ Proven PC Board Layout
- ◆ Fully Assembled and Tested Surface-Mount Board

Ordering Information

PART	TEMP. RANGE	IC PACKAGE
MAX4447EVKIT	0°C to +70°C	16 SO

Quick Start

The MAX4447 EV kit is fully assembled and tested. Follow these steps to verify board operation. **Do not turn on the power supply until all connections are completed.**

- 1) Connect a +5V power supply to the VCC pin and a -5V power supply to the VEE pin. Connect power-supply ground to the GND pads.
- 2) Ensure that the shunt is removed from jumper JU1.
- 3) Apply a signal of up to +1.5V peak to the SMA connector marked IN.
- 4) Connect the output marked OUT+ to a 50 Ω terminated oscilloscope input, and connect the output marked OUT- to another 50 Ω terminated oscilloscope input.
- 5) Turn on the power supply and verify the output signals on the oscilloscope. The output amplitude at either of the two outputs (VOUT+, VOUT-) observed on the oscilloscope will be the same as that on the input. This is due to the multiplication of the +2 gain with the voltage divider formed by the 49.9 Ω back-terminating resistor (R3) and the oscilloscope input termination. Note that the differential output (defined as VOUT+ - VOUT-) will be twice the amplitude of the input.

Evaluates: MAX4447/MAX4448/MAX4449

MAX4447 Evaluation Kit

Detailed Description

Enable Control

The MAX4447 provides an enable pin (EN) to enable or disable the output. Table 1 lists the options available for the enable/disable control jumper, JU1. EN is a TTL/CMOS-logic level input.

Layout Considerations

The MAX4447 EV kit layout has been optimized for high-speed signals with careful attention given to grounding, power-supply bypassing, and signal-path layout. The small, surface-mount, ceramic bypass capacitors (C2, C4) have been placed as close to the MAX4447 supply pins as possible. Signal traces have been kept as short as possible by using 0805-sized termination and gain-set resistors.

Evaluating the MAX4448 or MAX4449

To evaluate the MAX4448 or MAX4449, turn off the power to the EV kit. Replace the MAX4447 with a MAX4448ESE or MAX4449ESE, and install a gain-setting resistor R_G (0805, 1%) according to the following formula:

$$R_G = \frac{300\Omega}{G / 2 - 1}$$

Note that the gain must be at least +2V/V for the MAX4448 and must be at least +5V/V for the MAX4449 for the amplifier to be stable.

Table 1. Jumper JU1 Functions

SHUNT	MAX4447 ENABLE PIN	MAX4447 OUTPUT
Installed	Connected to GND	MAX4447 in shutdown
Not installed	Floating (internally pulled up)	MAX4447 enabled

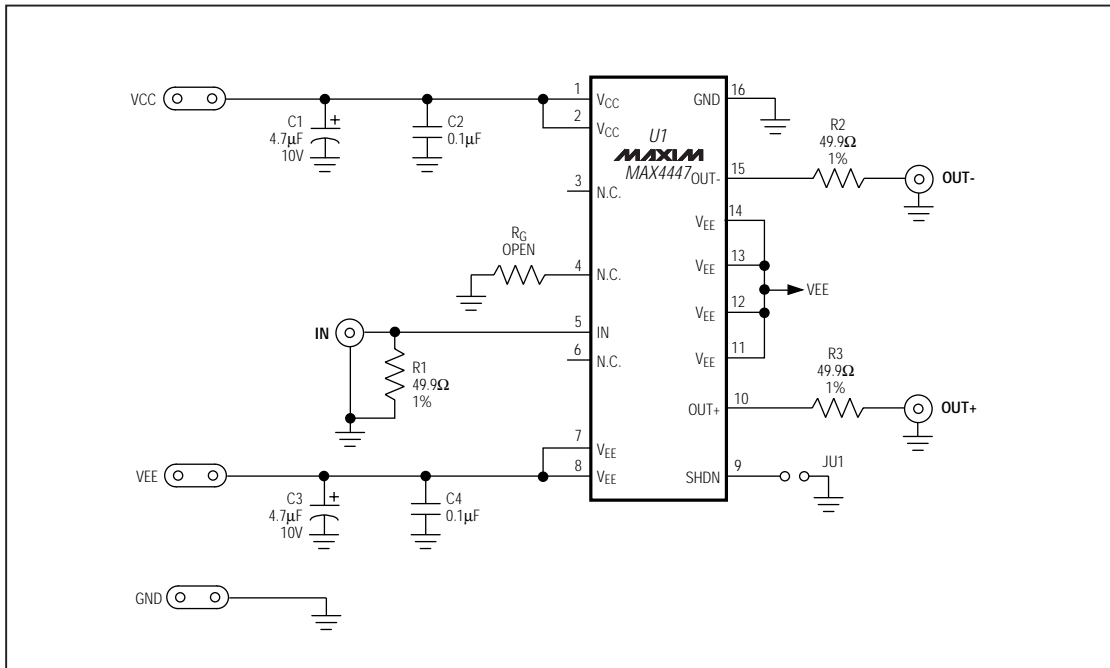

Figure 1. MAX4447 EV Kit Schematic

MAX4447 Evaluation Kit

Evaluates: MAX4447/MAX4448/MAX4449

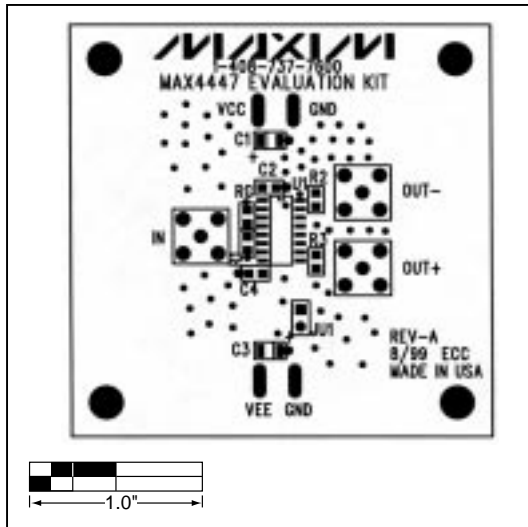

Figure 2. MAX4447 EV Kit Component Placement Guide—Component Side

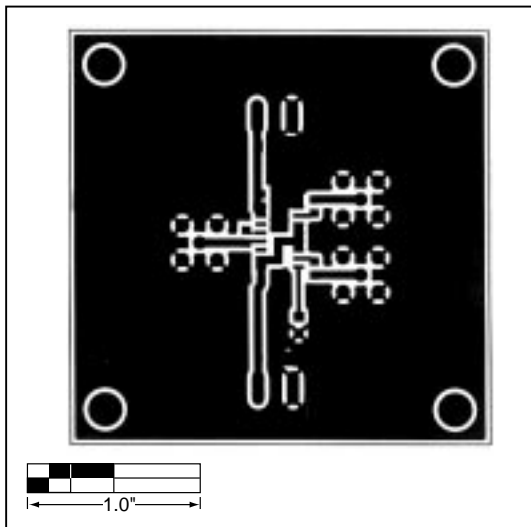

Figure 3. MAX4447 EV Kit PC Board Layout—Component Side

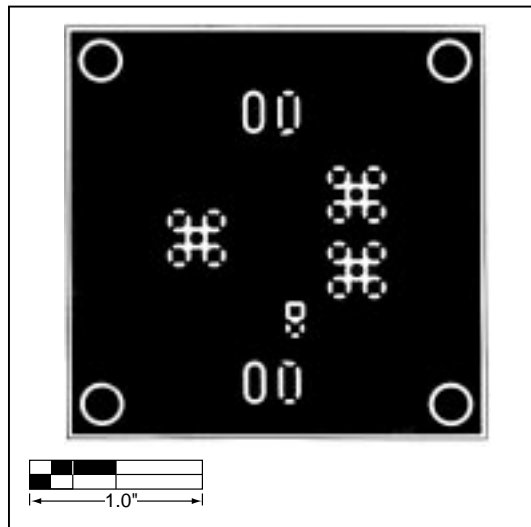

Figure 4. MAX4447 EV Kit PC Board Layout—Solder Side

MAX4447 Evaluation Kit

Evaluates: MAX4447/MAX4448/MAX4449

NOTES

Maxim cannot assume responsibility for use of any circuitry other than circuitry entirely embodied in a Maxim product. No circuit patent licenses are implied. Maxim reserves the right to change the circuitry and specifications without notice at any time.

4 _____ Maxim Integrated Products, 120 San Gabriel Drive, Sunnyvale, CA 94086 408-737-7600

© 1999 Maxim Integrated Products

Printed USA

MAXIM is a registered trademark of Maxim Integrated Products.