

2.4 GHz 2W MMIC

FEATURES

- P₋₁ dB: 33 dBm
- Small Signal Gain: 29 dB
- Power Added Efficiency: 31 %
- IP3: 42 dBm
- DC Bias: 800 mA @ 7 V

PHOTO ENLARGEMENT



DESCRIPTION

The TC3141 is a 2 stage PHEMT MMIC power amplifier. It is designed for use in low cost and high volume 2.4-2.5 GHz ISM band applications. The MMIC provides a typical gain of 29 dB and saturation power of more than 33 dBm. Typical bias condition is 7V at 800 mA. The MMIC is packaged in a standard SO-8 power package. The copper based carrier of the package allows direct soldering of the device to the PCB for proper heat sinking. The input and output matching of the MMIC require external components.

ELECTRICAL SPECIFICATIONS (Ta = 25 °C)

SYMBOL	DESCRIPTION	MIN	TYP	MAX	UNITS
FREQ	Frequency Range	2.4		2.5	GHz
SSG	Small Signal Gain	28	29		dB
P₋₁ dB	Output Power at 1 dB Gain Compression	32	33		dBm
P₋₃ dB	Output Power at 3 dB Gain Compression	33	34		dBm
IP3	Third Order Intercept Point	40	42		dBm
VSWR, IN	Input VSWR		2:1		-
VDD	Supply Voltage		7		Volt
Vg	Gate Voltage	-0.6	-1.2	-2	Volt
IDD	Current Supply Without RF		800		mA
IDP₋₁	Current Supply @ Pout = P ₋₁ dB		920		mA
η_a	Power Added Efficiency		31		%

Absolute Maximum Ratings

Symbol	Parameter/Conditions	Min.	Max.	Units
V_{dd}	Drain-Source Voltage		12	Volts
I_{dd}	Total Drain Current		2000	mA
P_{in}	RF Input Power		10	dBm
P_t	Power Dissipation		12	W
T_{ch}	Operating Channel Temperature		175	°C
T_{STG}	Storage Temperature	-65	175	°C

Note:

1. This GaAs MMIC is susceptible to damage from Electrostatic Discharge. Proper precautions should be used when handling these devices.
2. Specifications subject to change without notice.

TEST CIRCUITS

Evaluation Board Schematic

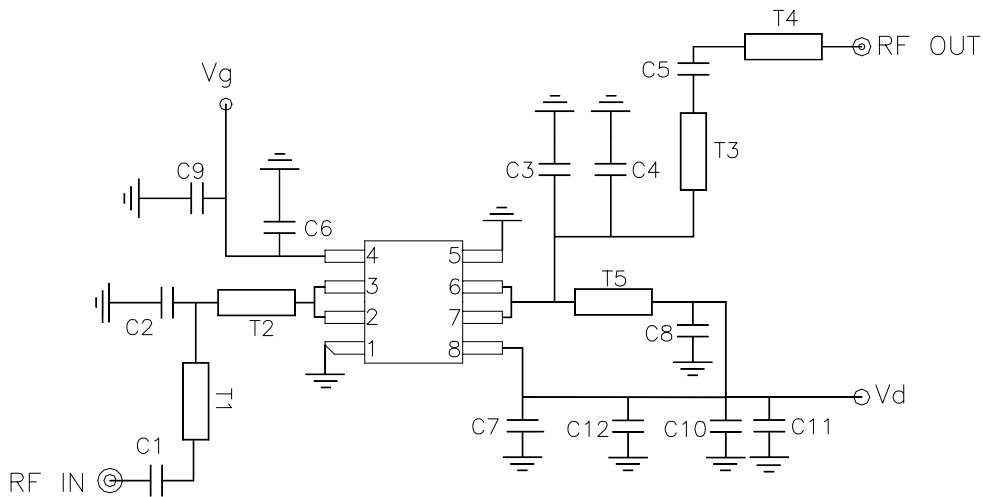
EVALUATION BOARD

PCB Material: FR4
 ER = 4.6
 Thickness = 31 mil
 Unit: mil

* DXF file of the PCB can be downloaded from our web-site at

www.transcominc.com.tw

* Application Notes:

For better heat sinking and grounding, it's recommended to have the via holes beneath TC3141 filled with solder and have two screws besides TC3141 installed on the PCB area.

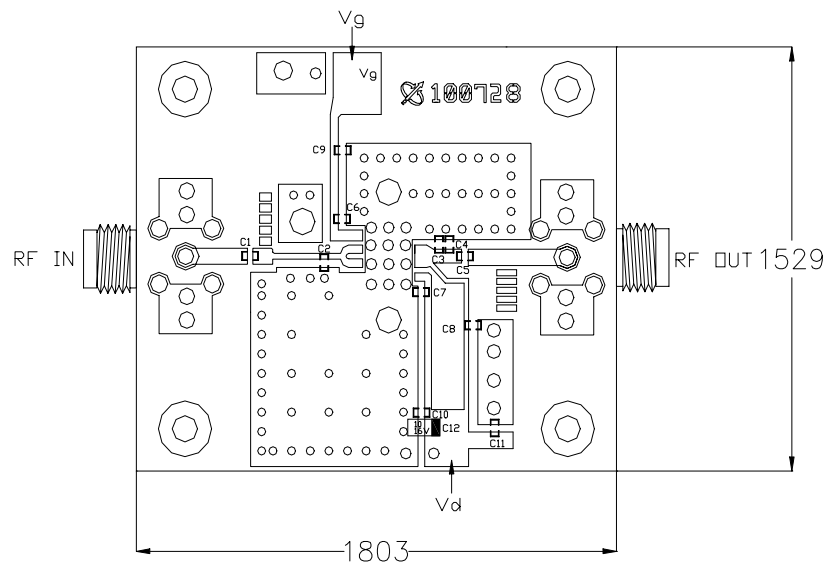

Evaluation Board Parts List

Part Type	Reference Designator	Description	Manufacturer	Part Number
Capacitor	C1	3.3 pF 0603	Murata	GRM39C0G3R3C50V
Capacitor	C2	2.5 pF 0603	Murata	GRM39C0G2R5C50V
Capacitor	C3	1 pF 0603	Murata	GRM39C0G010C50V
Capacitor	C4	0.75pF	Murata	GRM39C0GR75C50V
Capacitor	C5	1.5 pF 0603	Murata	GRM39C0G1R5C50V
Capacitor	C6~8	1000 pF 0603	Murata	GRM39C0G102J50V
Capacitor	C9~11	0.1 uF 0603	Murata	GRM39Y5V104Z25V
Capacitor	C12	4.7uF 1206 Tantalum Cap		

CONNECTION DIAGRAM AND PIN DESCRIPTIONS

Pin #	Name	Description
2, 3	RF IN	RF input (internally DC blocked)
1, 5	GND	Ground
4	V _g	FET gate bias
6, 7	RF OUT	RF output and V _{d2} External matching circuit required
8	V _d	Input stage drain bias

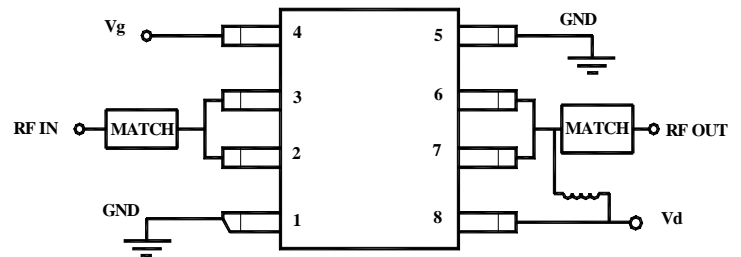
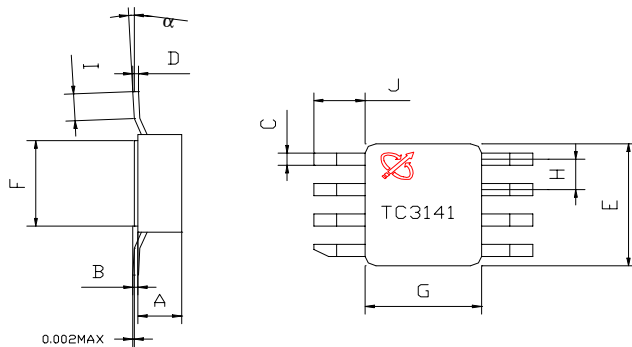
PHYSICAL DIMENSIONS (Unit: inch)

DIMENSION	MINIMUM	NOMINAL	MAXIMUM
A	0.083	0.086	0.089
B	0.007	0.008	0.009
C	0.017	0.020	0.023
D	0.007	0.008	0.009
E	0.195	0.200	0.205
F	0.135	0.140	0.145
G	0.155	0.160	0.165
H		0.050	
I	0.020		0.040
J	0.055	0.065	0.075
α	0°		7°