



5V/3.3V 4GHz,
÷ 4 PECL/LVPECL DIVIDER

Precision Edge®
SY10EP33V
SY100EP33V

FEATURES

- Guaranteed maximum frequency >4GHz
- 3.3V and 5V power supply options
- Guaranteed propagation delay <460ps over temperature
- Wide operating temperature range: -40°C to +85°C
- Available in 8-pin MSOP and SOIC packages



ECL Pro™

DESCRIPTION

The SY10/100EP33V is an integrated ÷4 divider.

The V_{BB} pin, an internally generated voltage supply, is available to this device only. For single-ended input conditions, the unused differential input is connected to V_{BB} as a switching reference voltage. V_{BB} may also rebias AC-coupled inputs. When used, decouple V_{BB} to V_{CC} via a 0.01 μ F capacitor and limit current sourcing or sinking to 0.5mA. When not used, V_{BB} should be left open.

The reset pin is asynchronous and is asserted on the rising edge. Upon power-up, the internal flip-flops will attain a random state; the reset allows for the synchronous use of multiple EP33s in a system.

The 100K Series includes internal temperature compensation circuitry.

PIN NAMES

Pin	Function
CLK, /CLK	ECL Clock Inputs with Internal 75k Ω Pull-Down Resistor, Default State is LOW
RESET	ECL Asynchronous Reset
V_{BB}	Reference Voltage Output
Q, /Q	ECL Data Outputs

TRUTH TABLE⁽¹⁾

CLK	/CLK	RESET	Q	/Q
X	X	Z ⁽²⁾	L	H
$\overline{1}$	$\overline{1}$	L	F	F

Notes:

1. F = Divide by 4 function.
2. Z = Low to High transition.

PACKAGE/ORDERING INFORMATION

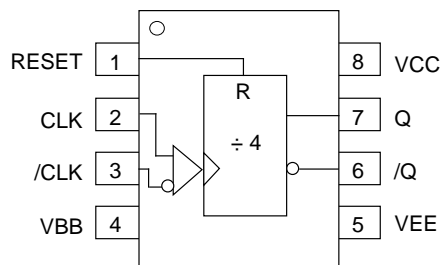

TOP VIEW
 (Available in MSOP or SOIC package)

Ordering Information⁽¹⁾

Part Number	Package Type	Operating Range	Package Marking	Lead Finish
SY10EP33VZC	Z8-1	Commercial	HEP33V	Sn-Pb
SY10EP33VZCTR ⁽²⁾	Z8-1	Commercial	HEP33V	Sn-Pb
SY100EP33VZC	Z8-1	Commercial	XEP33V	Sn-Pb
SY100EP33VZCTR ⁽²⁾	Z8-1	Commercial	XEP33V	Sn-Pb
SY10EP33VKC	K8-1	Commercial	HP33	Sn-Pb
SY10EP33VKCTR ⁽²⁾	K8-1	Commercial	HP33	Sn-Pb
SY100EP33VKC	K8-1	Commercial	XP33	Sn-Pb
SY100EP33VKCTR ⁽²⁾	K8-1	Commercial	XP33	Sn-Pb
SY10EP33VZI	Z8-1	Industrial	HEP33V	Sn-Pb
SY10EP33VZITR ⁽²⁾	Z8-1	Industrial	HEP33V	Sn-Pb
SY100EP33VZI	Z8-1	Industrial	XEP33V	Sn-Pb
SY100EP33VZITR ⁽²⁾	Z8-1	Industrial	XEP33V	Sn-Pb
SY10EP33VKI	K8-1	Industrial	HP33	Sn-Pb
SY10EP33VKITR ⁽²⁾	K8-1	Industrial	HP33	Sn-Pb
SY100EP33VKI	K8-1	Industrial	XP33	Sn-Pb
SY100EP33VKITR ⁽²⁾	K8-1	Industrial	XP33	Sn-Pb
SY10EP33VZG ⁽³⁾	Z8-1	Industrial	HEP33V with Pb-Free bar-line indicator	NiPdAu Pb-Free
SY10EP33VZGTR ^(2, 3)	Z8-1	Industrial	HEP33V with Pb-Free bar-line indicator	NiPdAu Pb-Free
SY100EP33VZG ⁽³⁾	Z8-1	Industrial	XEP33V with Pb-Free bar-line indicator	NiPdAu Pb-Free
SY100EP33VZGTR ^(2, 3)	Z8-1	Industrial	XEP33V with Pb-Free bar-line indicator	NiPdAu Pb-Free
SY10EP33VKG ⁽³⁾	K8-1	Industrial	HP33 with Pb-Free bar-line indicator	NiPdAu Pb-Free
SY10EP33VKGTR ^(2, 3)	K8-1	Industrial	HP33 with Pb-Free bar-line indicator	NiPdAu Pb-Free
SY100EP33VKG ⁽³⁾	K8-1	Industrial	XP33 with Pb-Free bar-line indicator	NiPdAu Pb-Free
SY100EP33VKGTR ^(2, 3)	K8-1	Industrial	XP33 with Pb-Free bar-line indicator	NiPdAu Pb-Free

Notes:

1. Contact factory for die availability. Dice are guaranteed at T_A = 25°C, DC Electricals only.
2. Tape and Reel.
3. Pb-Free package is recommended for new designs.

ABSOLUTE MAXIMUM RATINGS⁽¹⁾

Symbol	Rating	Value	Unit
V _{CC}	Power Supply Voltage (V _{EE} = 0)	+6.0 to 0	V
V _{EE}	Power Supply Voltage (V _{CC} = 0)	-6.0 to 0	V
V _{IN}	Input Voltage (V _{CC} = 0V, V _{IN} not more negative than V _{EE}) Input Voltage (V _{EE} = 0V, V _{IN} not more positive than V _{CC})	-6.0 to 0 +6.0 to 0	V V
I _{OUT}	Output Current -Continuous -Surge	50 100	mA
T _A	Operating Temperature Range	-40 to +85	°C
T _{LEAD}	Lead Temperature	+260	°C
T _{store}	Storage Temperature Range	-65 to +150	°C
θ _{JA}	Thermal Resistance (Junction-to-Ambient) SOIC-8 -Still Air -500lfpm	160	°C/W
		109	°C/W
	MSOP-8 -Still Air -500lfpm	206	°C/W
		155	°C/W
θ _{JC}	Thermal Resistance (Junction-to-Case) SOIC-8 MSOP-8	39	°C/W
		39	°C/W

- Note:**
1. Permanent device damage may occur if absolute maximum ratings are exceeded. This is a stress rating only and functional operation is not implied at conditions other than those detailed in the operational sections of this data sheet. Exposure to absolute maximum rating conditions for extended periods may affect device reliability.

(10EP) LVPECL DC ELECTRICAL CHARACTERISTICS⁽¹⁾

V_{CC} = +3.3V ±10%; V_{EE} = 0V⁽²⁾

Symbol	Parameter	T _A = -40°C			T _A = +25°C			T _A = +85°C			Unit
		Min.	Typ.	Max.	Min.	Typ.	Max.	Min.	Typ.	Max.	
I _{EE}	Power Supply Current	—	—	36	—	26	36	—	—	36	mA
V _{OH}	Output HIGH Voltage ⁽³⁾	2165	2290	2415	2230	2355	2480	2290	2415	2540	mV
V _{OL}	Output LOW Voltage ⁽³⁾	1365	1490	1615	1430	1555	1680	1490	1615	1740	mV
V _{IH}	Input HIGH Voltage (Single-Ended)	2090	—	2415	2155	—	2480	2215	—	2540	mV
V _{IL}	Input LOW Voltage (Single-Ended)	1365	—	1690	1430	—	1755	1490	—	1815	mV
V _{BB}	Output Voltage	1790	1890	1990	1885	1955	2055	1915	2015	2115	mV
V _{IHCMR}	Input HIGH Voltage ⁽⁴⁾ Common Mode Range (Differential)	2.0	—	V _{CC}	2.0	—	V _{CC}	2.0	—	V _{CC}	V
I _{IH}	Input HIGH Current	—	—	150	—	—	150	—	—	150	μA
I _{IL}	Input LOW Current RESET, CLK /CLK	0.5 -150	— —	— —	0.5 -150	— —	— —	0.5 -150	— —	— —	μA

- Notes:**
1. 10EP circuits are designed to meet the DC specifications shown in the above table after thermal equilibrium has been established. The circuit is in a test socket or mounted on a printed circuit board and traverse airflow greater than 500lfpm is maintained.
 2. Input and output parameters vary 1:1 with V_{CC}.
 3. All loading with 50Ω to V_{CC} -2.0V.
 4. The V_{IHCMR} range is referenced to the most positive side of the differential input signal.

(10EP) PECL DC ELECTRICAL CHARACTERISTICS⁽¹⁾

$V_{CC} = +5.0V \pm 10\%$; $V_{EE} = 0V^{(2)}$

Symbol	Parameter	$T_A = -40^\circ C$			$T_A = +25^\circ C$			$T_A = +85^\circ C$			Unit
		Min.	Typ.	Max.	Min.	Typ.	Max.	Min.	Typ.	Max.	
I_{EE}	Power Supply Current	—	—	36	—	26	36	—	—	36	mA
V_{OH}	Output HIGH Voltage ⁽³⁾	3865	3990	4115	3930	4055	4180	3990	4115	4240	mV
V_{OL}	Output LOW Voltage ⁽³⁾	3065	3190	3315	3130	3255	3380	3190	3315	3440	mV
V_{IH}	Input HIGH Voltage (Single-Ended)	3790	—	4115	3855	—	4180	3915	—	4240	mV
V_{IL}	Input LOW Voltage (Single-Ended)	3065	—	3390	3130	—	3455	3190	—	3515	mV
V_{BB}	Output Voltage	3490	3590	3690	3555	3655	3755	3615	3715	3815	mV
V_{IHCMR}	Input HIGH Voltage ⁽⁴⁾ Common Mode Range (Differential)	2.0	—	V_{CC}	2.0	—	V_{CC}	2.0	—	V_{CC}	V
I_{IH}	Input HIGH Current	—	—	150	—	—	150	—	—	150	μA
I_{IL}	Input LOW Current RESET, CLK /CLK	0.5 -150	— —	— —	0.5 -150	— —	— —	0.5 -150	— —	— —	μA

Notes:

- 10EP circuits are designed to meet the DC specifications shown in the above table after thermal equilibrium has been established. The circuit is in a test socket or mounted on a printed circuit board and traverse airflow greater than 500lfpm is maintained.
- Input and output parameters vary 1:1 with V_{CC} .
- All loading with 50Ω to $V_{CC} - 2.0V$.
- The V_{IHCMR} range is referenced to the most positive side of the differential input signal.

(10EP) ECL/LVECL DC ELECTRICAL CHARACTERISTICS⁽¹⁾

$V_{CC} = 0V$; $V_{EE} = -3.3V$ to $-5.0V \pm 10\%^{(2)}$

Symbol	Parameter	$T_A = -40^\circ C$			$T_A = +25^\circ C$			$T_A = +85^\circ C$			Unit
		Min.	Typ.	Max.	Min.	Typ.	Max.	Min.	Typ.	Max.	
I_{EE}	Power Supply Current	—	—	36	—	26	36	—	—	36	mA
V_{OH}	Output HIGH Voltage ⁽³⁾	-1135	-1010	-885	-1070	-945	-820	-1010	-885	-760	mV
V_{OL}	Output LOW Voltage ⁽³⁾	-1935	-1810	-1685	-1870	-1745	-1620	-1810	-1685	-1560	mV
V_{IH}	Input HIGH Voltage (Single-Ended)	-1210	—	-885	-1145	—	-820	-1085	—	-760	mV
V_{IL}	Input LOW Voltage (Single-Ended)	-1935	—	-1610	-1870	—	-1545	-1810	—	-1485	mV
V_{BB}	Output Voltage	-1510	-1410	-1310	-1445	-1345	-1245	-1385	-1285	-1185	mV
V_{IHCMR}	Input HIGH Voltage ⁽⁴⁾ Common Mode Range (Differential)	$V_{EE} + 2.0$		0.0	$V_{EE} + 2.0$		0.0	$V_{EE} + 2.0$		0.0	V
I_{IH}	Input HIGH Current	—	—	150	—	—	150	—	—	150	μA
I_{IL}	Input LOW Current RESET, CLK /CLK	0.5 -150	— —	— —	0.5 -150	— —	— —	0.5 -150	— —	— —	μA

Notes:

- 10EP circuits are designed to meet the DC specifications shown in the above table after thermal equilibrium has been established. The circuit is in a test socket or mounted on a printed circuit board and traverse airflow greater than 500lfpm is maintained.
- Input and output parameters vary 1:1 with V_{CC} .
- All loading with 50Ω to $V_{CC} - 2.0V$.
- V_{IHCMR} (Min) varies 1:1 with V_{EE} . The V_{IHCMR} range is referenced to the most positive side of the differential input signal.

(100EP) LVPECL DC ELECTRICAL CHARACTERISTICS⁽¹⁾

$V_{CC} = +3.3V \pm 10\%$; $V_{EE} = 0V^{(2)}$

Symbol	Parameter	$T_A = -40^\circ C$			$T_A = +25^\circ C$			$T_A = +85^\circ C$			Unit
		Min.	Typ.	Max.	Min.	Typ.	Max.	Min.	Typ.	Max.	
I_{EE}	Power Supply Current	—	—	36	—	30	36	—	—	40	mA
V_{OH}	Output HIGH Voltage ⁽³⁾	2155	2280	2405	2155	2280	2405	2155	2280	2405	mV
V_{OL}	Output LOW Voltage ⁽³⁾	1355	1480	1605	1355	1480	1605	1355	1480	1605	mV
V_{IH}	Input HIGH Voltage (Single-Ended)	2075	—	2420	2075	—	2420	2075	—	2420	mV
V_{IL}	Input LOW Voltage (Single-Ended)	1355	—	1675	1355	—	1675	1355	—	1675	mV
V_{BB}	Output Voltage	1775	1875	1975	1775	1875	1975	1775	1875	1975	mV
V_{IHCMR}	Input HIGH Voltage ⁽⁴⁾ Common Mode Range (Differential)	2.0	—	V_{CC}	2.0	—	V_{CC}	2.0	—	V_{CC}	V
I_{IH}	Input HIGH Current	—	—	150	—	—	150	—	—	150	μA
I_{IL}	Input LOW Current RESET, CLK /CLK	0.5 -150	— —	— —	0.5 -150	— —	— —	0.5 -150	— —	— —	μA

Notes:

- 100EP circuits are designed to meet the DC specifications shown in the above table after thermal equilibrium has been established. The circuit is in a test socket or mounted on a printed circuit board and traverse airflow greater than 500lfpm is maintained.
- Input and output parameters vary 1:1 with V_{CC} .
- All loading with 50Ω to $V_{CC} - 2.0V$.
- The V_{IHCMR} range is referenced to the most positive side of the differential input signal.

(100EP) PECL DC ELECTRICAL CHARACTERISTICS⁽¹⁾

$V_{CC} = +5.0V \pm 10\%$; $V_{EE} = 0V^{(2)}$

Symbol	Parameter	$T_A = -40^\circ C$			$T_A = +25^\circ C$			$T_A = +85^\circ C$			Unit
		Min.	Typ.	Max.	Min.	Typ.	Max.	Min.	Typ.	Max.	
I_{EE}	Power Supply Current	—	—	36	—	30	36	—	—	40	mA
V_{OH}	Output HIGH Voltage ⁽³⁾	3855	3980	4105	3855	3980	4105	3855	3980	4105	mV
V_{OL}	Output LOW Voltage ⁽³⁾	3055	3180	3305	3055	3180	3305	3055	3180	3305	mV
V_{IH}	Input HIGH Voltage (Single-Ended)	3775	—	4120	3775	—	4120	3775	—	4120	mV
V_{IL}	Input LOW Voltage (Single-Ended)	3055	—	3375	3055	—	3375	3055	—	3375	mV
V_{BB}	Output Voltage	3475	3575	3675	3475	3575	3675	3475	3575	3675	mV
V_{IHCMR}	Input HIGH Voltage ⁽⁴⁾ Common Mode Range (Differential)	2.0	—	V_{CC}	2.0	—	V_{CC}	2.0	—	V_{CC}	V
I_{IH}	Input HIGH Current	—	—	150	—	—	150	—	—	150	μA
I_{IL}	Input LOW Current RESET, CLK /CLK	0.5 -150	— —	— —	0.5 -150	— —	— —	0.5 -150	— —	— —	μA

Notes:

- 100EP circuits are designed to meet the DC specifications shown in the above table after thermal equilibrium has been established. The circuit is in a test socket or mounted on a printed circuit board and traverse airflow greater than 500lfpm is maintained.
- Input and output parameters vary 1:1 with V_{CC} .
- All loading with 50Ω to $V_{CC} - 2.0V$.
- The V_{IHCMR} range is referenced to the most positive side of the differential input signal.

(100EP) ECL/LVECL DC ELECTRICAL CHARACTERISTICS⁽¹⁾

$V_{CC} = 0V$; $V_{EE} = -3.3V$ to $-5.0V \pm 10\%$ ⁽²⁾

Symbol	Parameter	$T_A = -40^\circ C$			$T_A = +25^\circ C$			$T_A = +85^\circ C$			Unit
		Min.	Typ.	Max.	Min.	Typ.	Max.	Min.	Typ.	Max.	
I_{EE}	Power Supply Current	—	—	36	—	30	36	—	—	40	mA
V_{OH}	Output HIGH Voltage ⁽³⁾	-1145	-1020	-895	-1145	-1020	-895	-1145	-1020	-895	mV
V_{OL}	Output LOW Voltage ⁽³⁾	-1945	-1820	-1695	-1945	-1820	-1695	-1945	-1820	-1695	mV
V_{IH}	Input HIGH Voltage (Single-Ended)	-1225	—	-880	-1225	—	-880	-1225	—	-880	mV
V_{IL}	Input LOW Voltage (Single-Ended)	-1945	—	-1625	-1945	—	-1625	-1945	—	-1625	mV
V_{BB}	Output Voltage	-1525	-1425	-1325	-1525	-1425	-1325	-1525	-1425	-1325	mV
V_{IHCMR}	Input HIGH Voltage ⁽⁴⁾ Common Mode Range (Differential)	$V_{EE} + 2.0$		0.0	$V_{EE} + 2.0$		0.0	$V_{EE} + 2.0$		0.0	V
I_{IH}	Input HIGH Current	—	—	150	—	—	150	—	—	150	μA
I_{IL}	Input LOW Current RESET, CLK /CLK	0.5 -150	— —	— —	0.5 -150	— —	— —	0.5 -150	— —	— —	μA

Notes:

- 100EP circuits are designed to meet the DC specifications shown in the above table after thermal equilibrium has been established. The circuit is in a test socket or mounted on a printed circuit board and traverse airflow greater than 500lfpm is maintained.
- Input and output parameters vary 1:1 with V_{CC} .
- All loading with 50Ω to $V_{CC} - 2.0V$.
- V_{IHCMR} (Min) varies 1:1 with V_{EE} . The V_{IHCMR} range is referenced to the most positive side of the differential input signal.

TIMING DIAGRAM

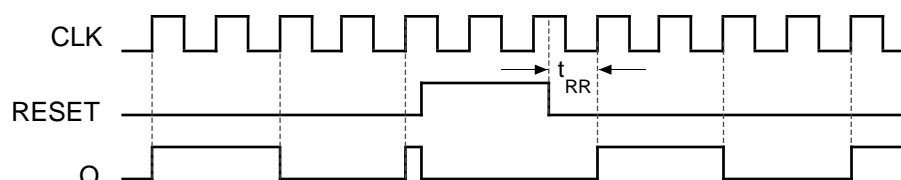

AC ELECTRICAL CHARACTERISTICS(1, 2)

NECL: $V_{CC} = 0V$, $V_{EE} = -3.3V$ to $-5.0V \pm 10\%$; PECL: $V_{EE} = 0V$, $V_{CC} = +3.3V$ to $+5.0V \pm 10\%$.

Symbol	Parameter	$T_A = -40^\circ C$			$T_A = +25^\circ C$			$T_A = +85^\circ C$			Unit
		Min.	Typ.	Max.	Min.	Typ.	Max.	Min.	Typ.	Max.	
f_{MAX}	Maximum Frequency ⁽³⁾	4	—	—	4	—	—	4	—	—	GHz
t_{PLH} t_{PHL}	Propagation Delay to Output CLK → Q (SY10EP33V) RESET → Q (SY100EP33V) RESET → Q	300 300 310	380 420 420	440 470 470	300 290 310	380 420 420	440 470 470	320 320 320	400 450 450	460 500 500	ps
t_{RR}	Set/Reset Recovery	200	—	—	200	100	—	200	—	—	ps
t_{PW}	Minimum Pulse Width RESET	550	—	—	550	200	—	550	—	—	ps
t_{JITTER}	Cycle-to-Cycle RMS Jitter ⁽³⁾	—	0.2	< 1	—	0.2	< 1	—	0.2	< 1	ps(rms)
V_{PP}	Input Voltage Swing (Differential)	150	800	1200	150	800	1200	150	800	1200	mV
t_r t_f	Output Rise/Fall Times Q, /Q (20% to 80%)	90	170	200	100	180	220	120	200	240	ps

Notes:

1. Measured using a 750mV source, 50% duty cycle clock source. All loading with 50Ω to $V_{CC} - 2.0V$.
2. Specifications for packaged product only.
3. f_{MAX} guaranteed for functionality only. V_{OL} and V_{OH} levels are guaranteed at DC only.

8 LEAD MSOP (K8-1)

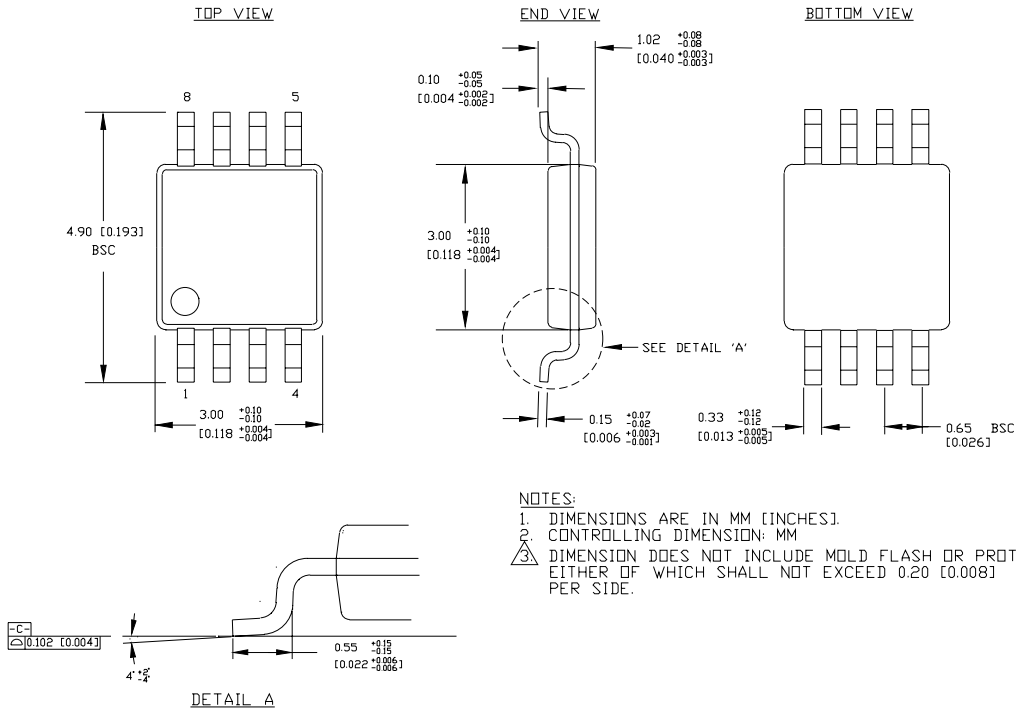

Rev.01

8 LEAD SOIC .150" WIDE (Z8-1)

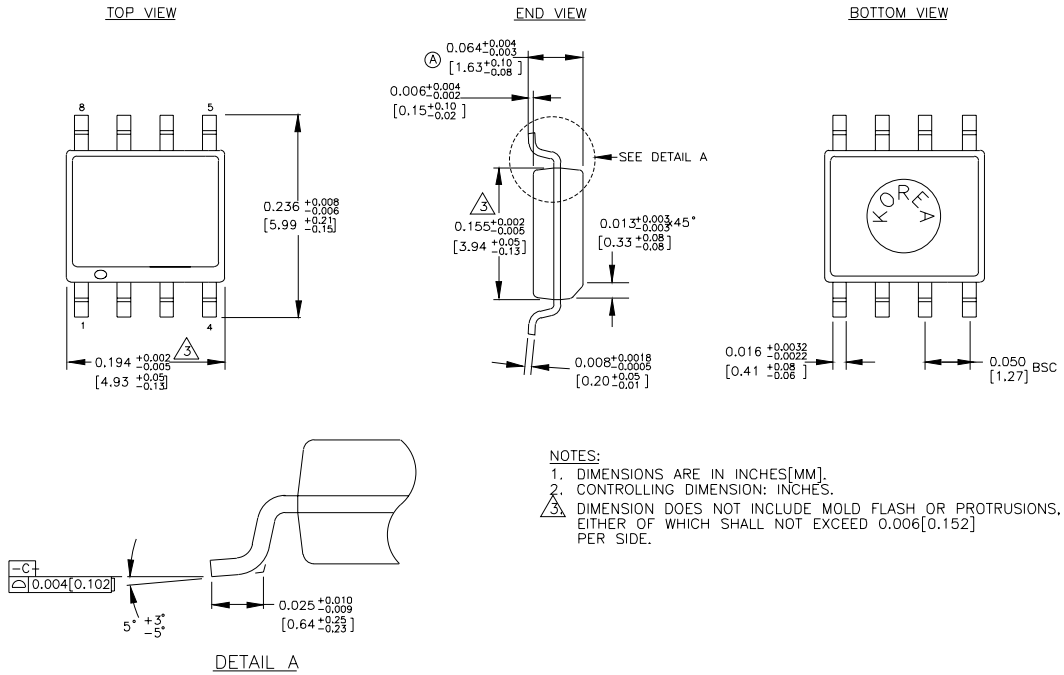

Rev. 03

MICREL, INC. 2180 FORTUNE DRIVE SAN JOSE, CA 95131 USA

TEL + 1 (408) 944-0800 FAX + 1 (408) 474-1000 WEB <http://www.micrel.com>

The information furnished by Micrel in this datasheet is believed to be accurate and reliable. However, no responsibility is assumed by Micrel for its use. Micrel reserves the right to change circuitry and specifications at any time without notification to the customer.

Micrel Products are not designed or authorized for use as components in life support appliances, devices or systems where malfunction of a product can reasonably be expected to result in personal injury. Life support devices or systems are devices or systems that (a) are intended for surgical implant into the body or (b) support or sustain life, and whose failure to perform can be reasonably expected to result in a significant injury to the user. A Purchaser's use or sale of Micrel Products for use in life support appliances, devices or systems is at Purchaser's own risk and Purchaser agrees to fully indemnify Micrel for any damages resulting from such use or sale.

© 2003 Micrel, Incorporated.