



SANYO Semiconductors

DATA SHEET

An ON Semiconductor Company

LV2285VB — Bi-CMOS IC FM transmitter IC with Stereo Modulation, Auto Sleep Function

Overview

The LV2285VB is IC for FM transmitter. This IC is chiefly composed of the following block. MPX block for stereo modulation, RFVCO block for FM modulation, and PLL block for RF output frequency. At the result, this IC achieves FM transmitter with low power consumption by 1chip.

Additionally, the auto sleep function is installed. This function automatically switches the standby and active according to the state of the audio input. It is possible to achieve a more dynamic electric power reduction as a result.

Feature

- The function necessary for FM transmission has been integrated into 1chip.
- The best low current consumption operation for portable application
- The auto sleep function to reduce more dynamic current consumption
- General I²C I/F and, SANYO original audio control I/F is installed

Functions

- Audio: Stereo modulation using pilot tone system, Audio attenuation
- RF: VCO, programmable gain driver amplifier
- Bus control: I²C I/F, Audio control I/F
- PLL: 70MHz to 110MHz 100kHz step
- Regulator: 2.8V LDO regulator, Auto sleep function

Specifications

Maximum Ratings at Ta = 25°C

Parameter	Symbol	Conditions	Ratings	Unit
Maximum supply voltage	V _{CC} max	Pin 6	7.0	V
Maximum input voltage	V _{in} max		V _{CC} + 0.3	V
Minimum input voltage	V _{in} min		-0.3	V
Allowable power dissipation	P _d max	Ta ≤ 85°C, Mounted on a specified board.*	500	mW
Operating temperature	T _{opr}		-10 to 85	°C
Storage temperature	T _{stg}		-55 to 150	°C

* Specified board: 114.3mm × 76.1mm × 1.6mm, glass epoxy board.

■ Any and all SANYO Semiconductor Co.,Ltd. products described or contained herein are, with regard to "standard application", intended for the use as general electronics equipment (home appliances, AV equipment, communication device, office equipment, industrial equipment etc.). The products mentioned herein shall not be intended for use for any "special application" (medical equipment whose purpose is to sustain life, aerospace instrument, nuclear control device, burning appliances, transportation machine, traffic signal system, safety equipment etc.) that shall require extremely high level of reliability and can directly threaten human lives in case of failure or malfunction of the product or may cause harm to human bodies, nor shall they grant any guarantee thereof. If you should intend to use our products for applications outside the standard applications of our customer who is considering such use and/or outside the scope of our intended standard applications, please consult with us prior to the intended use. If there is no consultation or inquiry before the intended use, our customer shall be solely responsible for the use.

■ Specifications of any and all SANYO Semiconductor Co.,Ltd. products described or contained herein stipulate the performance, characteristics, and functions of the described products in the independent state, and are not guarantees of the performance, characteristics, and functions of the described products as mounted in the customer's products or equipment. To verify symptoms and states that cannot be evaluated in an independent device, the customer should always evaluate and test devices mounted in the customer's products or equipment.

SANYO Semiconductor Co., Ltd.

<http://semicon.sanyo.com/en/network>

LV2285VB

Recommended Operating Conditions at Ta = 25°C

Parameter	Symbol	Conditions	Ratings	Unit
Recommended Supply voltage	V _{CC}	Pin 6	3.3	V
Operating supply voltage	V _{CC op}	Pin 6	2.8 to 5.5	V

Electrical Characteristics at Ta = 25°C, V_{CC} = 3.3V, L/R input = 1kHz, 425mVrms, I²C bits = Initial

Parameter	Symbol	Conditions	Ratings			Unit
			min	typ	max	
Circuit current	I _{CC}	Pin 6 (No signal)		8	10	mA
Standby current	I _{STB}	Pin 6 (No signal, I ² C"EN"="0")		40	60	μA
Audio and MPX Block						
Minimum audio input	V _Δ MIN	Pin 1 and 24 input	30			mVrms
Maximum audio input	V _Δ MAX	Pin 1 and 24 input			900	mVrms
Audio input frequency	FAF	Pin 1 and 24 input	20		15k	Hz
Channel separation	SEP	Pin 7, composite output, L>R, R>L	20	40		dB
Channel balance	CB	Pin 7, composite output	-2	0	+2	dB
Total harmonic distortion	THD	Pin 7, composite output		0.1	0.3	%
Pilot tone output level	PMOD	I ² C bits "ST"="1", "PILOT"="1"	0.5	0.85	1.2	mVpp
Composite output level	MPXOUT		2.9	3.8	4.6	mVrms
Audio mute	MUTE	I ² C bit "MUTE"="1"	30	35		dB
Audio attenuation step	ATT(1)	ATT[2:0] = "111" – "110"		2.3		dB
	ATT(2)	ATT[2:0] = "110" – "101"		2.2		dB
	ATT(3)	ATT[2:0] = "101" – "100"		2.8		dB
	ATT(4)	ATT[2:0] = "100" – "011"		2.3		dB
	ATT(5)	ATT[2:0] = "011" – "010"		4.3		dB
	ATT(6)	ATT[2:0] = "010" – "001"		3.3		dB
	ATT(7)	ATT[2:0] = "001" – "000"		1.6		dB
Crystal Oscillator Frequency(1)	FXOSC(1)	Pin 21 and Pin22		76		kHz
Audio control Block						
Audio Control Frequency	F _{CONT}	Pin 2 and 23 input		7.5		kHz
Audio Control input	V _{CONT}	Pin 2 and 23 input		1.2		Vp-p
Auto sleep Block						
Turn-off time	T _{OFF}	The time from no signal to turn-off. If the V _{CC} voltage is supplied, LV2285VB maintains I ² C data. Ctc (Pin 20) = 2.2μF	45	70	300	sec
PLL Block						
I ² C input "High" voltage	V _H		0.8V _{CC}		V _{CC} +0.3	V
I ² C input "Low" voltage	V _L		-0.3		0.2V _{CC}	V
RF input frequency	F _{PLL}	Step = 100kHz, See table 2	70		110	MHz
Crystal Oscillator frequency	FXOSC(2)	Pin 16		16	-	MHz
External Clock Frequency	F _{EXT}	<ul style="list-style-type: none"> External clock injection to Pin 16 instead of 16MHz crystal oscillation. When the LSI is standby mode, external clock should be stop. 	1		24	MHz
CP output current	I _{CP}	CP voltage = 1.4V		30		μA
RF Block						
RF output	R _F OUT	f = 98MHz, RF[2:0] = "011", Pin 12 output	109	112	115	dBμV
RF output adjustment step	R _F STEP	RF[2:0] = "000" to "111", totally 8 steps.	0.3	0.9	1.4	dB
RF frequency	F _{RF}	100kHz step	70		110	MHz
I²C Block						
I ² C input switch	I ₂ CSW *	Input to Pin 2/23 : Audio control I/F	-0.3		0.2V _{CC}	V
		Input to Pin 17/18 : I ² C I/F	0.8V _{CC}		V _{CC} +0.3	V

* Use case (I²C I/F) : Please set Pin 19 = High.

LV2285VB

Package Dimensions

unit : mm (typ)
3287

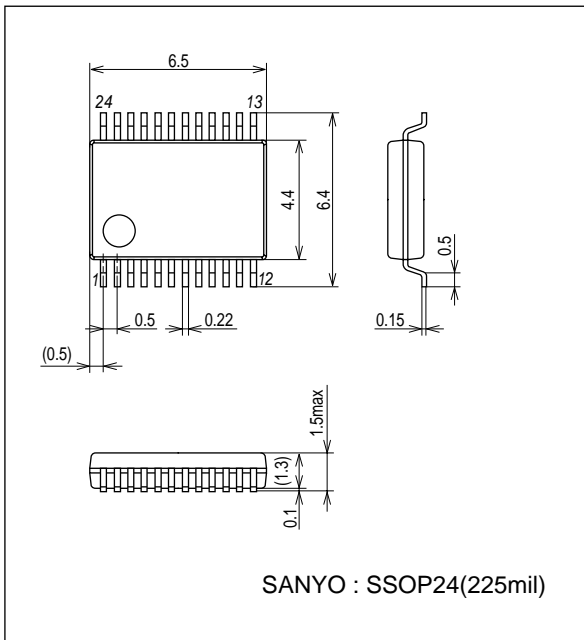

Pin Assignment

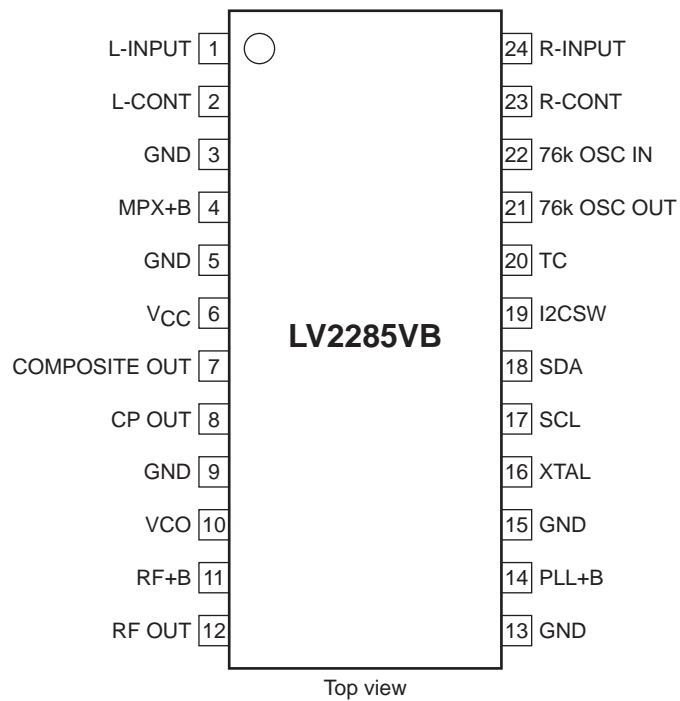

LV2285VB

Block Diagram and Application Circuit Example

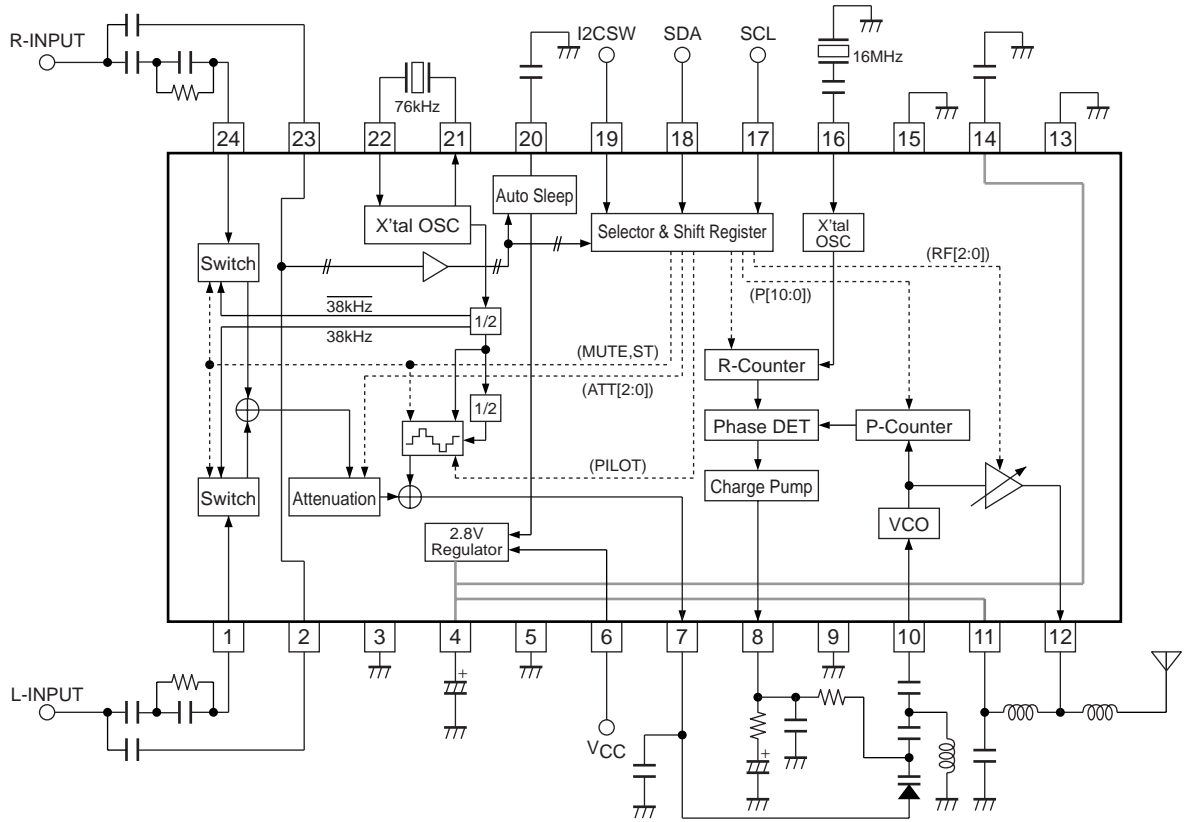

LV2285VB

Pin Function

Pin No.	Pin name	DC voltage (V)	Function	Equivalent circuit
1	L-INPUT	0	Left channel input. If audio source DC voltage is not 0V, AC coupling capacitance is required. Pre-emphasis capacitance and resistance should be required.	
2	L-CONT	1.2	Data input pin for Audio control. External coupling capacitance is required.	
3	GND	0		
4	MPX+B	2.8	LDO regulator output. External decoupling capacitance is required.	
5	GND	0		
6	VCC	3.3		
7	COMPOSITE OUT		Stereo modulated output.	
8	CP OUT		Charge pump current output.	
9	GND	0		

Continued on next page.

LV2285VB

Continued from preceding page.

Pin No.	Pin name	DC voltage (V)	Function	Equivalent circuit
10	VCO	2.2	Transistor BASE pin for Colpitz oscillator.	
11	RF+B	2.8	LDO regulator output for RF blocks.	
12	RF OUT	2.8	Collector output. Inductance should be connected Between pin 11 and pin 12 for getting resonant frequency and making pin 12 DC bias 2.8V.	
13	GND	0		
14	PLL+B	2.8	LDO regulator output for digital blocks.	
15	GND	0		
16	XTAL		16MHz crystal is needed for PLL reference frequency. If external clock is injected to pin 16. Frequency should be from 1MHz to 24MHz and $N(\text{integer}) \times 200\text{kHz}$.	
17	SCL		I ² C clock input.	

Continued on next page.

LV2285VB

Continued from preceding page.

Pin No.	Pin name	DC voltage (V)	Function	Equivalent circuit
18	SDA		I ² C data input.	
19	I2CSW		The change switch of the I ² C data input pin. When Pin 19 = GND case, Audio control I/F is selected (Pin 2/23). In one side, when Pin 19 = V _{CC} case, I ² C I/F is selected (Pin 17/18).	
20	TC	2.8	Connect capacitance. Turn-off time is in proportion to this capacity value.	
21	76k OSC OUT	2.0	For stereo modulator pilot signal and sub carrier. 76kHz crystal should be connected between Pin 21 and Pin 22.	
22	76k OSC IN	0.7	See pin 21.	See pin 21.
23	R-CONT	1.2	Clock Input for Audio Control. See Pin 2	See pin 2.
24	R-INPUT	0	See pin 1.	See pin 1.

LV2285VB

I²C Bus Definition

Table 1 : I²C Register map

Name	Byte	Bit								ACK
		MSB *1				LSB				
Address Byte	1	AD7	AD6	AD5	AD4	AD3	AD2	AD1	R/W	A
		1	1	0	1	0	0	0	0	
Control Byte 1	2	P10	P9	P8	P7	P6	P5	P4	P3	A
		0	1	1	1	1	0	1	0	
Control Byte 2	3	P2	P1	P0	RES2	ST	PILOT	EN	MUTE	A
		1	0	0	0	1	1	0	0	
Control Byte 3	4	RES1	RES0	RF2	RF1	RF0	ATT2	ATT1	ATT0	A
		*2	*2	0	1	1	0	1	0	
Control Byte 4	5	R6	R5	R4	R3	R2	R1	R0	TEST	A
		1	0	1	0	0	0	0	0	

*1 : MSB is transmitted first.

*2 : Don't care

Table 2 : I²C Register map description

Bit	Name	Initial	Description
AD[7:0]	Address bit	1101 000	LV2285VB I ² C 7bit address
R/W	Read / Write	0	Write mode only
A	Acknowledge		
P[10:0]	Programmable counter	0111 1010 100	11bit Programmable counter. RF frequency=(P10 × 2 ¹⁰ + P9 × 2 ⁹ + ... P1 × 2 ¹ + P0) × 100kHz
RES2	Reserved bit	0	
ST	MONO / Stereo	1 (stereo)	Stereo modulation control. "ST"="0" Monaural mode, "ST"="1" : Stereo mode.
PILOT	Pilot tone output	1	Pilot signal control. "PILOT"="0" : No pilot, "PILOT"="1" : with Pilot
EN	Enable	0 (Standby)	Internal LDO control. "EN"="1" : Active, "EN"="0" : Standby
MUTE	Mute	0	Audio mute control. "MUTE"="1" : Enable, "MUTE"="0" : Disable
RES[1:0]	Reserved bits	00	
RF[2:0]	RF output adjustment	011	RF output level control. RF[2:0]="111" : Maximum, RF[2:0]="000" : Minimum
ATT[2:0]	Audio attenuator	010	This attenuator is used to adjust FM modulation level."111" is Minimum (0dB)."000" is Maximum (19dB). See Audio and MPX Block specification.
R[6:0]	Reference counter	1010 000	7bit reference counter. Reference frequency should be set 100kHz. {Crystal oscillator frequency(Pin 16)}/{(R6 × 2 ⁶ + R5 × 2 ⁵ ...+R1 × 2 ¹ + R0) × 2} = 100kHz
TEST	Reserved bit	0	

LV2285VB

I²C Bus Operation

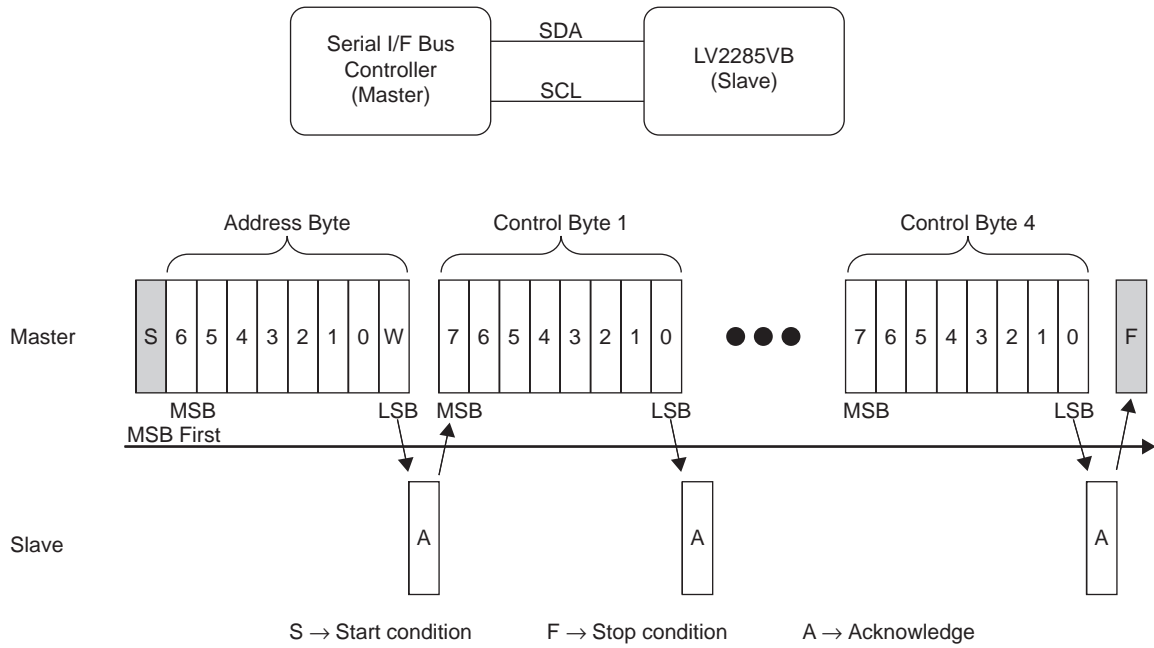

Time chart

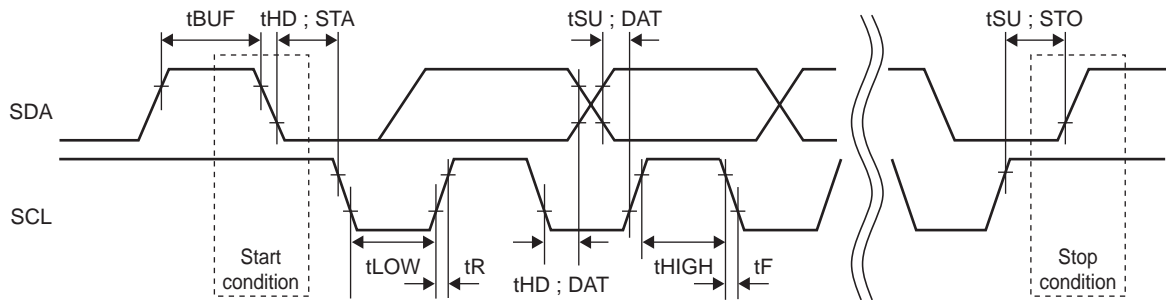

Table 3 : Timing specification

Parameter	Symbol	Ratings			unit
		min	typ	max	
SCL clock frequency	fSCL			100	kHz
Bus free time between a STOP and START condition	tBUF	4.7			μs
Hold time START condition	tHD;STA	4.0			μs
Low period of the SCL clock	tLOW	4.7			μs
High period of the SCL clock	tHIGH	4.0			μs
Data hold time	tHD;DAT	0.0			μs
Data set-up time	tSU;DAT	250			μs
Rise time of both SDA and SCL signals	tR			1000	ns
Fall time of both SDA and SCL signals	tF			300	ns
Set-up time for STOP condition	tSU;STO	4.0			μs

I²C Bus AC characteristics: Temp = 25°C, V_{CC} = 3.3V

Note: I²C Bus is registered trademark of the Philips Co..

Usage note

Stereo modulation

In generally, How to generate stereo modulating signals explain below figure 1. LV2285VB generate composite signal like below figure 2. And it is possible to control sub signals at register [ST]. Pilot signal is controlled at register [PILOT]

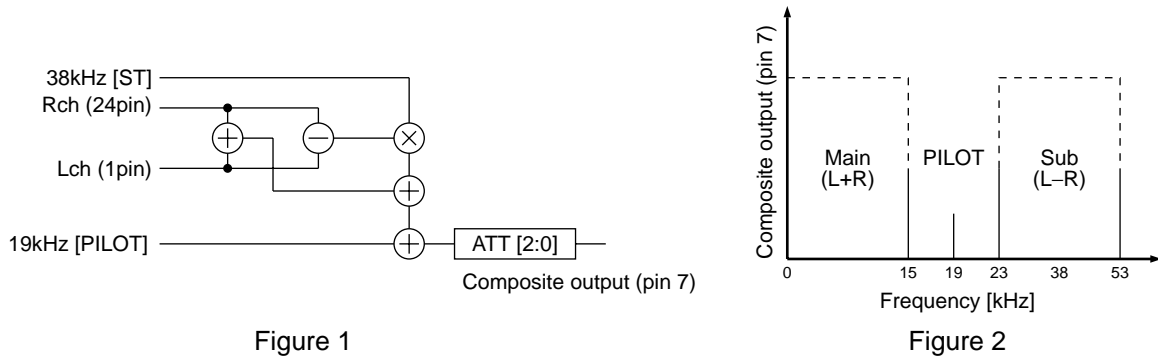

Figure 1

Figure 2

FM modulation

The LV2285VB have best performance of FM modulation at $\pm 75\text{kHzdev}$.

FM modulation level changes in proportion to composite output level (pin 7)

In LV2285VB composed of recommended parts, Table 1 is shown relationship that set ATT [2:0] value against audio input signal level.

Table 1

Audio input signal level V.S ATT[2:0] setting		
Large attenuation	000	L , R input level = 780mVrms
	001	L , R input level = 640mVrms
	010	L , R input level = 425mVrms
	011	L , R input level = 260mVrms
	100	L , R input level = 190mVrms
	101	L , R input level = 140mVrms
	110	L , R input level = 110mVrms
Small attenuation	111	L , R input level = 80mVrms

Please refer to Table 1 to obtain better audio quality.

LV2285VB

AC Test Circuit

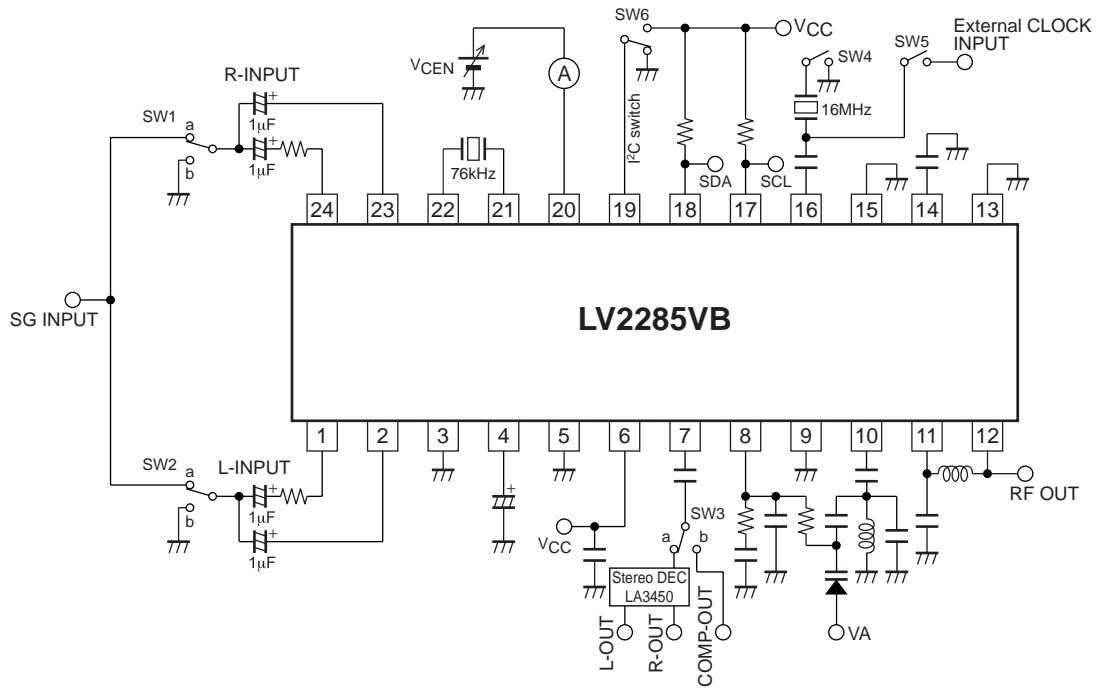

- SANYO Semiconductor Co.,Ltd. assumes no responsibility for equipment failures that result from using products at values that exceed, even momentarily, rated values (such as maximum ratings, operating condition ranges, or other parameters) listed in products specifications of any and all SANYO Semiconductor Co.,Ltd. products described or contained herein.
- SANYO Semiconductor Co.,Ltd. strives to supply high-quality high-reliability products, however, any and all semiconductor products fail or malfunction with some probability. It is possible that these probabilistic failures or malfunction could give rise to accidents or events that could endanger human lives, trouble that could give rise to smoke or fire, or accidents that could cause damage to other property. When designing equipment, adopt safety measures so that these kinds of accidents or events cannot occur. Such measures include but are not limited to protective circuits and error prevention circuits for safe design, redundant design, and structural design.
- In the event that any or all SANYO Semiconductor Co.,Ltd. products described or contained herein are controlled under any of applicable local export control laws and regulations, such products may require the export license from the authorities concerned in accordance with the above law.
- No part of this publication may be reproduced or transmitted in any form or by any means, electronic or mechanical, including photocopying and recording, or any information storage or retrieval system, or otherwise, without the prior written consent of SANYO Semiconductor Co.,Ltd.
- Any and all information described or contained herein are subject to change without notice due to product/technology improvement, etc. When designing equipment, refer to the "Delivery Specification" for the SANYO Semiconductor Co.,Ltd. product that you intend to use.
- Information (including circuit diagrams and circuit parameters) herein is for example only; it is not guaranteed for volume production.
- Upon using the technical information or products described herein, neither warranty nor license shall be granted with regard to intellectual property rights or any other rights of SANYO Semiconductor Co.,Ltd. or any third party. SANYO Semiconductor Co.,Ltd. shall not be liable for any claim or suits with regard to a third party's intellectual property rights which has resulted from the use of the technical information and products mentioned above.

This catalog provides information as of May, 2011. Specifications and information herein are subject to change without notice.