

MARK: KINGS 129-23-9(DATE CODE)

7/16-28 UNEF-2A TH'D
(BOTH ENDS)

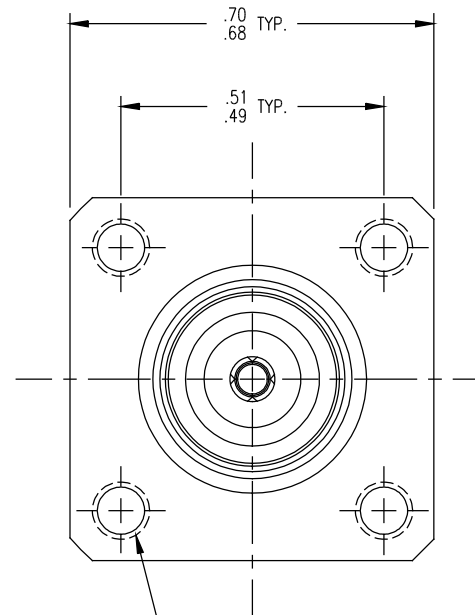

4-40 UNC-2B TH'D
(4 PLACES)

NOTES:

1. FOR USE WITH .075 MAX. PANEL.
2. INTERFACE PER MIL-STD-348, SERIES TNC SOCKET CONTACT.
3. MARK PACKAGE: KINGS 129-23-9(DATE CODE)
4. MATERIALS:
 CENTER CONTACT-BER. COP., ASTM B196
 INSULATOR-TEFLON, ASTM D1710
 ALL OTHER METAL PARTS-BRASS, ASTM B16
5. FINISHES:
 CENTER CONTACT- .000050 MIN GOLD PLATE, PER ASTM B488 OVER
 .000050 MIN. NICKEL PER AMS-QQ-N-290 (RoHS)
 ALL OTHER METAL PARTS-.000050 MIN NICKEL PER AMS-QQ-N-290
 OVER .000050 MIN COPPER PER ASTM B734 (RoHS)
6. ELECTRICAL CHARACTERISTICS:
 NOMINAL IMPEDANCE-50 OHMS
 FREQUENCY RANGE-DC TO 11 GHZ
 WORKING VOLTAGE-500 VRMS
7. WEIGHT: 15.9 GRAMS

129-23-9

REVISIONS

ISSUE	CHANGES
0	ER 35710 KH 08/01/94
B	REVISED PER DMF304 & ER041051 KPL 03/26/12

CUSTOMER
SALES
DRAWING

THIS DRAWING, THE DESIGNS AND IDEAS EMBODIED IN THE DEVICE TO WHICH IT RELATES, AND THE METHOD OF PRODUCING THE DEVICE, ARE THE PROPERTY OF WINCHESTER ELECTRONICS CORPORATION AND SHALL NOT BE EMPLOYED, COPIED, OR DISCLOSED TO ANYONE, IN ANY MANNER WITHOUT THE CONSENT OF WINCHESTER ELECTRONICS CORPORATION.

SCALE 4:1

APPROX SURFACE AREA

CAGE CODE: 91836

REF: BOEING

ADAPTER, F-F, PANEL, TNC

DRAWN KH	DATE 05/13/94
DESIGN JT	DATE 05/16/94
APPR.	DATE

KINGS
by WINCHESTER
ELECTRONICS
Winchester Electronics Corporation
62 Barnes Industrial Road North
Wallingford, Connecticut 06492

129-23-9