

6

5

4

3

2

1

MATERIAL AND FINISH:

Insulator: Polycarbonate, UL-94V-0 rated

Contacts: Brass, Nickel plated

ELECTRICAL SPECIFICATIONS:

Current rating: 10 A

Voltage rating: 250 VAC



Current rating: 15 A

Voltage rating: 250 VAC



ORDERING CODE:

42R01-5 2
 1 3

1 = COLOR

1 = BLACK

2 = GRAY

2 = M3x6.0mm

SCREW TERMINALS

3 = ELECTRICAL CIRCUIT CONFIGURATION

1 = 15A 250V 120°C
2+GROUND



2 = 15A 250V 70°C
2+GROUND



4 = 15A 250V 70°C
2 POLE

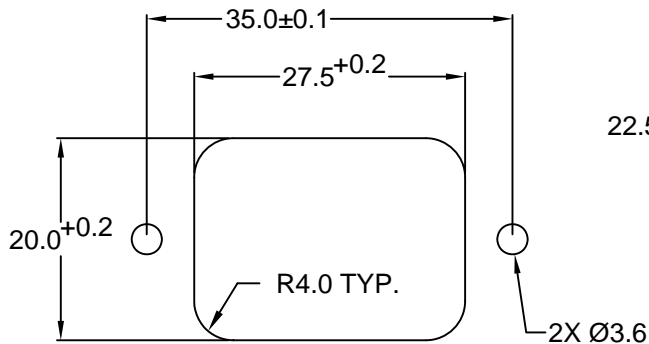
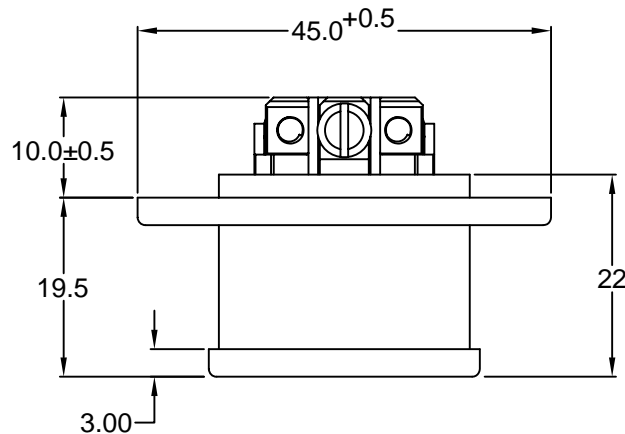
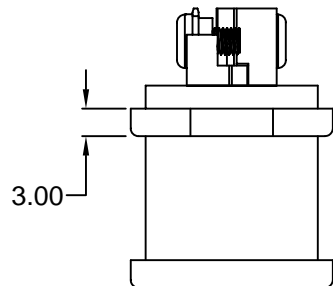

RECOMMENDED
PANEL CUTOUT

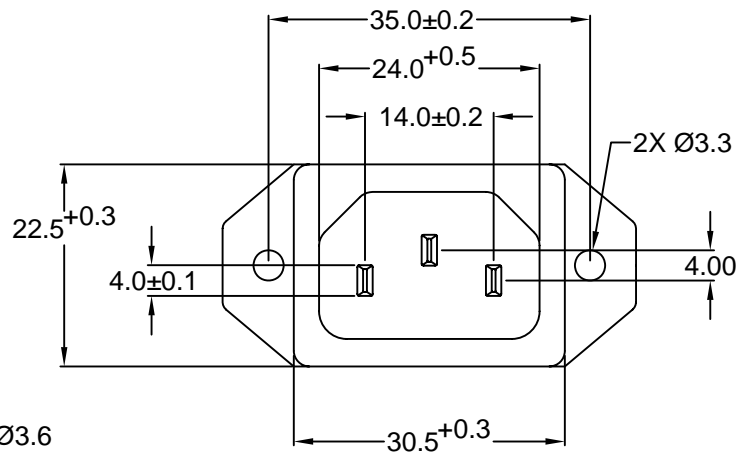

RoHS
COMPLIANT

REV	DATE	CHANGE	CHKG	CHK	APPR

TOLERANCE UNLESS OTHERWISE SPECIFIED			
X	± 1		
X.X	± 0.4		
X.XX	± 0.20		
DRAWN BY	GQ	DATE:	08/08/01
CHECK BY	TD	DATE:	08/14/01
APPR BY	PB	DATE:	08/14/01

Power Dynamics, Inc.
Phone: 973 560-0019 Whippany, New Jersey Fax: 973 560-0076

PART: IEC 60320 C14 APPL. INLET; SCREW
TERMINALS; BOTTOM FLANGE

PART #: 42R01-5X2X		SHEET 1 of 1
SIZE: A	ALL DIMENSIONS FOR REFERENCE ONLY DIMENSIONS ARE IN MILLIMETERS	REV:
SCALE: NTS		