

# 40V Precision Instrumentation Amplifier with Differential ADC Driver

## ISL28617

The ISL28617 is a high performance, differential input, differential output instrumentation amplifier designed for precision analog to digital applications. It can operate over a supply range of 8V ( $\pm 4V$ ) to 40V ( $\pm 20V$ ) and features a differential input voltage range up to  $\pm 34V$ . The output stage has rail-to-rail output drive capability optimized for differential ADC driver applications. Its versatility and small package makes it suitable for a variety of general purpose applications. Additional features not found in other instrumentation amplifiers enable high levels of DC precision and excellent AC performance.

The gain of the ISL28617 can be programmed from 0.1 to 10,000 via two external resistors,  $R_{IN}$  and  $R_{FB}$ . The gain accuracy is determined by the matching of  $R_{IN}$  and  $R_{FB}$ . The gain resistors have Kelvin sensing, which removes gain error due to PC trace resistance. The input and output stages have individual power supply pins, which enable input signals riding on a high common mode voltage to be level shifted to a low voltage device, such as an A/D converter. The rail-to-rail output stage can be powered from the same supplies as the ADC, which preserves the ADC maximum input dynamic range and eliminates ADC input overdrive.

The ISL28617 is offered in the 24 Ld TSSOP package, and is guaranteed over  $-40^{\circ}C$  to  $+125^{\circ}C$  operation.

## Related Literature

- "ISL28617VYXXEV1Z User's Guide" [AN1753](#)
- "ISL28617SMXXEV1Z User's Guide" [AN1748](#)

## Features

- Rail-to-rail Differential Output ADC Driver
- High Voltage Interface to Low Voltage Circuits
- Wide Operating Voltage Range . . . . .  $\pm 4V$  to  $\pm 20V$
- Low Input Offset . . . . .  $30\mu V$
- Excellent CMRR and PSRR . . . . . 120dB
- Closed Loop -3dB BW . . . . . 0.3MHz ( $A_V = 1k$ ) to 5MHz ( $A_V = 0.1$ )
- Operating Temperature Range . . . . .  $-40^{\circ}C$  to  $+125^{\circ}C$
- Package . . . . . 24 Ld TSSOP

## Applications

- Precision Test and Measurement
- High Voltage Industrial Process Control
- Signal Conditioning Amplifier for Remote Powered Sensors
- Weigh Scales
- ECG and Biomedical Sense Amplifiers

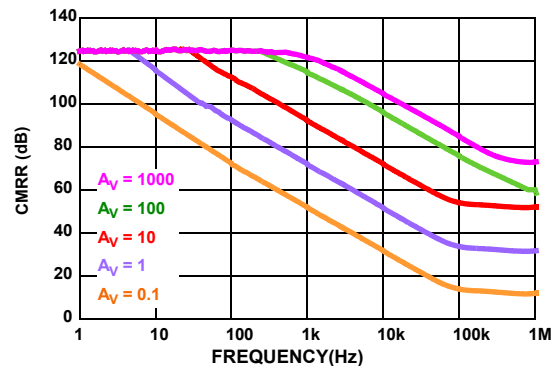

FIGURE 1. CMRR  $R_F = 121k$

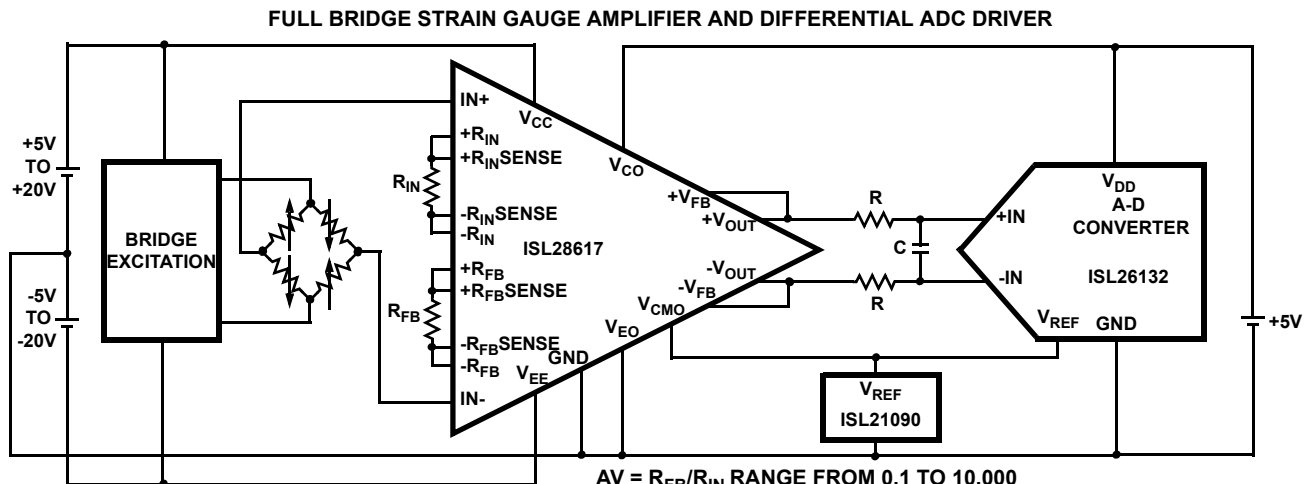
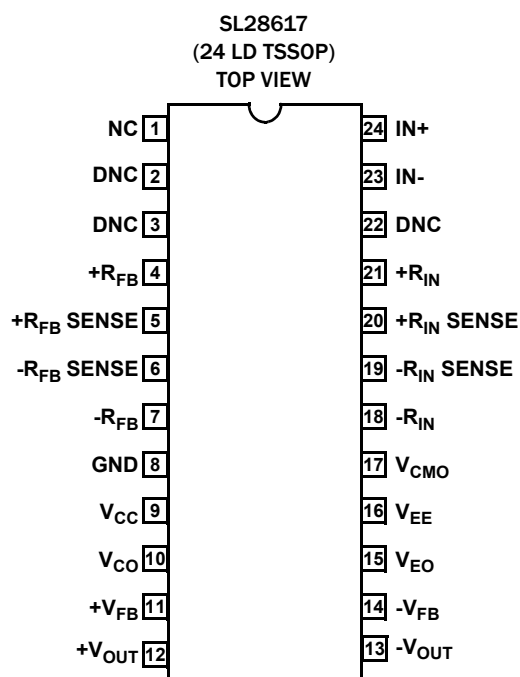

FIGURE 2. BASIC APPLICATION CIRCUIT



## Pin Descriptions

PIN NAME	PIN NUMBERS	DESCRIPTION
NC	1	No Internal Connection
DNC	2, 3, 22	For internal use; Do Not Connect
+R <sub>FB</sub>	4	Feedback Resistor, R <sub>FB</sub> <sup>+</sup> pin
+R <sub>FB</sub> SENSE	5	+R <sub>FB</sub> , Positive Sense pin connects to the resistor R <sub>FB</sub> <sup>+</sup> terminal to form the R <sub>FB</sub> <sup>+</sup> Kelvin connection
-R <sub>FB</sub> SENSE	6	-R <sub>FB</sub> , Negative Sense pin connects to the resistor R <sub>FB</sub> <sup>-</sup> terminal to form the R <sub>FB</sub> <sup>-</sup> Kelvin connection
-R <sub>FB</sub>	7	Feedback Resistor, Negative Terminal
GND	8	Ground Pin is capacitively coupled to the internal ESD circuit and should be connected to power supply common or signal GND.
V <sub>CC</sub>	9	Positive Supply for Input Stage and Feedback Amp
V <sub>CO</sub>	10	Positive Supply for Output Stage
+V <sub>FB</sub>	11	Positive Output Feedback
+V <sub>OUT</sub>	12	Positive Output
-V <sub>OUT</sub>	13	Negative Output
-V <sub>FB</sub>	14	Negative Output Feedback
V <sub>EO</sub>	15	Negative Supply for Output Stage
V <sub>EE</sub>	16	Negative Supply for Input Stage and Feedback Amp
V <sub>CMO</sub>	17	Output Common Mode Reference input
-R <sub>IN</sub>	18	Input Resistor, Negative Terminal
-R <sub>IN</sub> SENSE	19	-R <sub>IN</sub> , Negative Sense pin connects to the resistor R <sub>IN</sub> <sup>-</sup> terminal to form the R <sub>IN</sub> <sup>-</sup> Kelvin connection
+R <sub>IN</sub> SENSE	20	+R <sub>IN</sub> , Positive Sense pin connects to the resistor R <sub>IN</sub> <sup>+</sup> terminal to form the R <sub>IN</sub> <sup>+</sup> Kelvin connection
+R <sub>IN</sub>	21	Input Resistor, Positive Terminal
IN-	23	Negative Input
IN+	24	Positive Input

## Ordering Information

PART NUMBER (Notes 1, 2, 3)	PART MARKING	TEMP RANGE (°C)	PACKAGE (Pb-Free)	PKG. DWG. #
ISL28617FVZ	28617 FVZ	-40 °C to +125 °C	24 Ld TSSOP	M24.173

### NOTES:

1. Add "-T\*" suffix for tape and reel. Please refer to [TB347](#) for details on reel specifications.
2. These Intersil Pb-free plastic packaged products employ special Pb-free material sets, molding compounds/die attach materials, and 100% matte tin plate plus anneal (e3 termination finish, which is RoHS compliant and compatible with both SnPb and Pb-free soldering operations). Intersil Pb-free products are MSL classified at Pb-free peak reflow temperatures that meet or exceed the Pb-free requirements of IPC/JEDEC J STD-020.
3. For Moisture Sensitivity Level (MSL), please see device information page for [ISL28617](#). For more information on MSL please see tech brief [TB363](#).

## Simplified Block Diagram

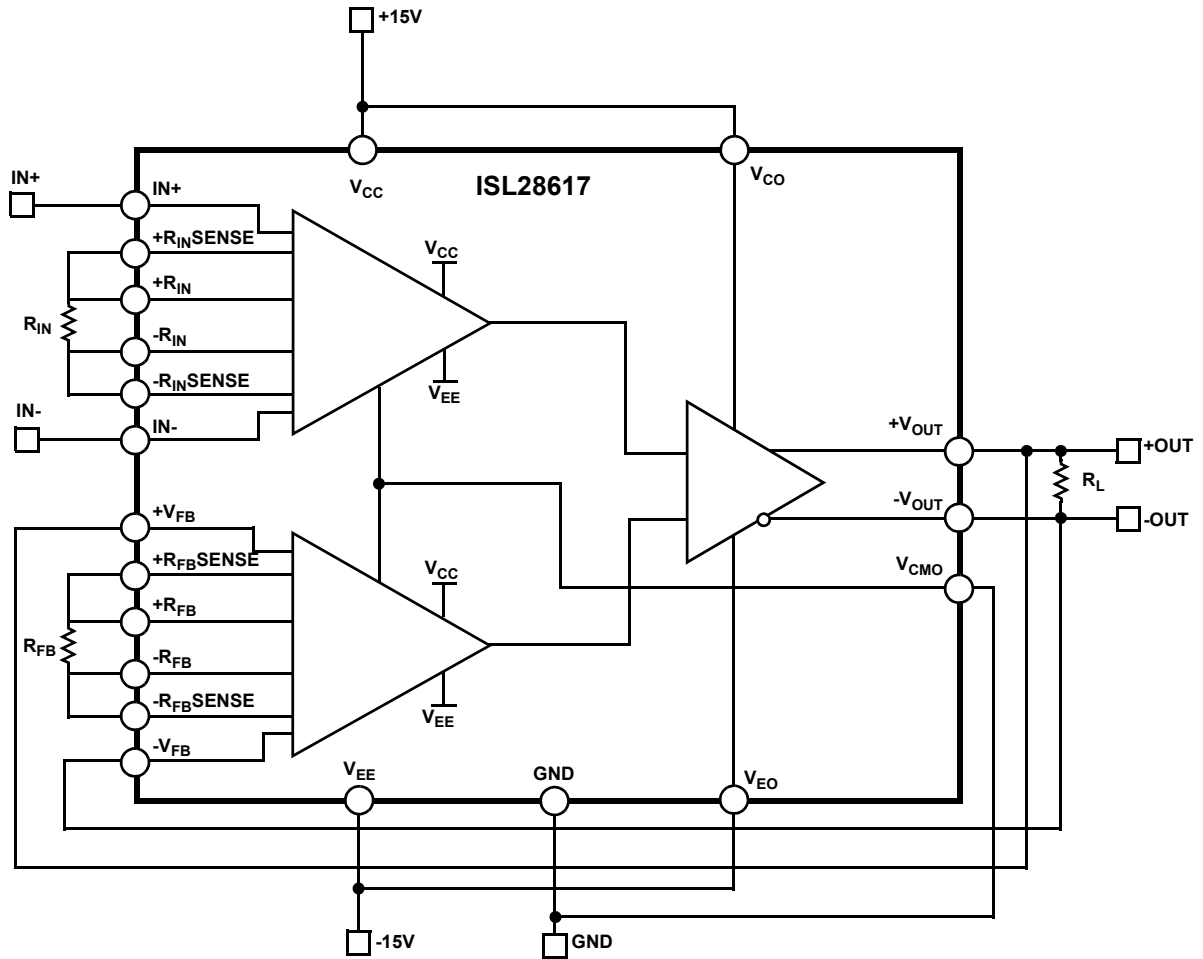

# ISL28617

## Absolute Maximum Ratings

Maximum Supply Voltage ( $V_{CC}$ to $V_{EE}$ or GND)	42V
Maximum Supply Voltage ( $V_{CO}$ to $V_{EO}$ or GND)	42V
Maximum Voltage ( $V_{CO}$ to $V_{CC}$ )	+0.5V, -40V
Maximum Voltage ( $V_{EO}$ to V-)	-0.5V, +40V
Maximum Differential Input Current	$\pm 10$ mA
Max/Min Input Current for Input Voltage $>V_{CC}$ or $<V_{EE}$	$\pm 10$ mA
Maximum Input Current ( $\pm I_{IN}$ , $\pm R_{FB}$ , $\pm R_{INSENSE}$ , $\pm R_{FBSENSE}$ )	$\pm 5$ mA
Maximum Differential Input Voltage	40V
Min/Max Input Voltage	( $V_{EE} - 0.5$ V) to ( $V_{CC} + 0.5$ V)
Output Short-Circuit Duration (1 Output at a Time)	Continuous
ESD Rating	
Human Body Model	4kV
Machine Model	200V
Charged Device Model	2kV

## Thermal Information

Thermal Resistance (Typical, Note 4)	$\theta_{JA}$ ( $^{\circ}$ C/W)
24 Ld TSSOP	74
Maximum Storage Temperature Range	-65 $^{\circ}$ C to +150 $^{\circ}$ C
Maximum Junction Temperature ( $T_{JMAX}$ )	+150 $^{\circ}$ C
Pb-Free Reflow Profile	see link below <a href="http://www.intersil.com/pbfree/Pb-FreeReflow.asp">http://www.intersil.com/pbfree/Pb-FreeReflow.asp</a>

## Recommended Operating Conditions

Ambient Temperature Range ( $T_A$ )	-40 $^{\circ}$ C to +125 $^{\circ}$ C
$V_{CC}$ , $V_{EE}$ Operating Voltage Range	$\pm 4$ V to $\pm 20$ V
$V_{CO}$ , $V_{E+}$ Operating Voltage Range	$\pm 1.5$ V to $\pm 20$ V

CAUTION: Do not operate at or near the maximum ratings listed for extended periods of time. Exposure to such conditions may adversely impact product reliability and result in failures not covered by warranty.

### NOTE:

- $\theta_{JA}$  is measured with the component mounted on a high effective thermal conductivity test board in free air. See Tech Brief [TB379](#) for details.

IMPORTANT NOTE: All parameters having Min/Max specifications are guaranteed. Typ values are for information purposes only. Unless otherwise noted, all tests are at the specified temperature and are pulsed tests, therefore:  $T_J = T_C = T_A$

**Electrical Specifications**  $V_{CC} = V_{CO} = 15$ V,  $V_{EE} = V_{EO} = -15$ V,  $V_{CM} = 0$ V,  $R_L = 10$ k $\Omega$ ,  $R_{FB} = R_{IN} = 30.1$ k $\Omega$ ,  $T_A = +25$  $^{\circ}$ C, unless otherwise specified. **Boldface limits apply over the operating temperature range, -40 $^{\circ}$ C to +125 $^{\circ}$ C.**

PARAMETER	DESCRIPTION	CONDITIONS	MIN (Note 5)	TYP	MAX (Note 5)	UNIT
<b>INPUT DC SPECIFICATIONS</b>						
$V_{CMIRIN}$	IN+, IN- Common Mode Input Voltage Range		$V_{EE} + 3$ V		$V_{CC} - 3$ V	V
$V_{OSIN}$	Input Offset Voltage		-100	$\pm 30$	100	$\mu$ V
			<b>-275</b>		<b>275</b>	$\mu$ V
$TCV_{OSIN}$	Input Offset Voltage Temperature Coefficient		<b>-2.75</b>	$\pm 0.3$	<b>2.75</b>	$\mu$ V/ $^{\circ}$ C
$I_{BIN}$	Input Bias Current		-1	$\pm 0.2$	1	nA
			<b>-1.3</b>		<b>1.3</b>	nA
$I_{OSIN}$	Input Offset Current		-0.75	$\pm 0.2$	0.75	nA
			<b>-1</b>		<b>1</b>	nA
$I_{RIN}$	Input Resistor Drive Current	(Note 9)	87	102	117	$\mu$ A
$R_{INCM}$	Common Mode Input Resistance			80		G $\Omega$
CMRR	Common Mode Rejection Ratio	$V_{EE} + 3$ V $\leq V_{CM} \leq V_{CC} - 3$ V G = 1	110	120		dB
			<b>107</b>			dB
		$V_{EE} + 3$ V $\leq V_{CM} \leq V_{CC} - 3$ V G = 100	130	150		dB
			<b>110</b>			dB
<b>FEEDBACK DC SPECIFICATIONS</b>						
$V_{CMIRFB}$	+FB, -FB Common Mode Input Voltage Range		$V_{EE} + 3$ V		$V_{CC} - 3$ V	V
$V_{OSFB}$	Feedback Input Offset Voltage		-1600	$\pm 400$	1600	$\mu$ V
			<b>-3000</b>		<b>3000</b>	$\mu$ V
$I_{BV_{FB+,-}}$	Input Bias Current at $V_{FB} \pm$ Inputs			15		nA

# ISL28617

**Electrical Specifications**  $V_{CC} = V_{CO} = 15V$ ,  $V_{EE} = V_{EO} = -15V$ ,  $V_{CM} = 0V$ ,  $R_L = 10k\Omega$ ,  $R_{FB} = R_{IN} = 30.1k\Omega$ ,  $T_A = +25^\circ C$ , unless otherwise specified. **Boldface limits apply over the operating temperature range,  $-40^\circ C$  to  $+125^\circ C$ .** (Continued)

PARAMETER	DESCRIPTION	CONDITIONS	MIN (Note 5)	TYP	MAX (Note 5)	UNIT
<b>OUTPUT DC SPECIFICATIONS</b>						
$V_{OL}$	Output Voltage Low, $V_{OUT}$ to $V_-$	$V_{CC} = +15V$ , $V_{EE} = -15V$ , $V_{CO} = +4V$ , $V_{EO} = -4V$ $R_{IN} = R_F = 121k\Omega$ , $I_{OUT} = 1.5mA$		150	200	mV
					<b>200</b>	mV
$V_{OH}$	Output Voltage High, $V_+$ to $V_{OUT}$	$V_{CC} = +15V$ , $V_{EE} = -15V$ , $V_{CO} = +4V$ , $V_{EO} = -4V$ $R_{IN} = R_F = 121k\Omega$ , $I_{OUT} = 1.5mA$		150	200	mV
					<b>200</b>	mV
$I_{SC}$	Output Short Circuit Current	$R_L = 0\Omega$ to GND		$\pm 45$		mA
				<b>-20</b>	<b>20</b>	mA
$I_{ERR}$	Total Internal Offset Error Current (Note 8)			$\pm 5$	17	nA
				<b>-90</b>	<b>90</b>	nA
$E_G$	Gain Error (Notes 6, 7)	$V_{OUT} = -10V$ to $+10V$ , $R_F = 121k\Omega$				
			$G = 1$		$\pm 0.003$	%
		$G = 100$		$\pm 0.004$	%	
		$V_{OUT} = -2.5V$ to $+2.5V$ , $R_F = 30.1k\Omega$				
$G = 1$			$\pm 0.0005$	%		
<b>OUTPUT COMMON MODE SPECIFICATIONS</b>						
$V_{CMO}^{CMIR}$	Output Common Mode Control Input Voltage Range		$V_{EE} +3V$		$V_{CC} -3V$	V
$V_{OS}^{CM}$	Output Common Mode Offset Voltage from $V_{CMO}$ Input			$\pm 0.5$	1.3	mV
				<b>-4.75</b>	<b>4.75</b>	mV
$I_B^{V_{CMO}}$	Input Bias Current at $V_{CMO}$ Input			$\pm 0.2$	0.6	$\mu A$
				<b>-1.75</b>	<b>1.75</b>	$\mu A$
<b>POWER SUPPLY SPECIFICATIONS</b>						
$I_{CC}$	Supply Current, $V_{CC}$ to $V_{EE}$	$R_L = OPEN$		2.05	2.2	mA
					<b>2.85</b>	mA
$I_{CO}$	Supply Current, $V_{CO}$ to $V_{EO}$	$R_L = OPEN$		2.25	2.6	mA
					<b>2.85</b>	mA
$V_{CC}$ to $V_{EE}$	Input Supply Voltage	Dual Supply	$\pm 4$		$\pm 20$	V
		Single Supply	8		40	V
$V_{CO}$ to $V_{EO}$	Output Supply Voltage	Dual Supply	$\pm 1.5$		$\pm 20$	V
		Single Supply	3		40	V
PSRR $V_{CC}$ to $V_{EE}$	Power Supply Rejection Ratio	$V_{CC}$ to $V_{EE} = \pm 4V$ to $\pm 20V$ $G = 100$		123	130	dB
				<b>118</b>		dB
PSRR $V_{CO}$ to $V_{EO}$	Power Supply Rejection Ratio	$V_{CO}$ to $V_{EO} = \pm 4V$ to $\pm 20V$		110	120	dB
				<b>110</b>		dB
<b>AC SPECIFICATIONS</b>						
$e_N$	Input Noise Voltage Density	$f = 1kHz$		8.6		nV/ $\sqrt{Hz}$
$e_{N,rms}$	Input rms Noise Voltage	$f = 0.1$ to $10Hz$		85		nVrms

# ISL28617

**Electrical Specifications**  $V_{CC} = V_{CO} = 15V$ ,  $V_{EE} = V_{EO} = -15V$ ,  $V_{CM} = 0V$ ,  $R_L = 10k\Omega$ ,  $R_{FB} = R_{IN} = 30.1k\Omega$ ,  $T_A = +25^\circ C$ , unless otherwise specified. **Boldface limits apply over the operating temperature range,  $-40^\circ C$  to  $+125^\circ C$ .** (Continued)

PARAMETER	DESCRIPTION	CONDITIONS	MIN (Note 5)	TYP	MAX (Note 5)	UNIT
$i_N$	Input Noise Current Density	$f = 1kHz$		150		$fA/\sqrt{Hz}$
$i_{NIERR}$	Total Internal Noise Current Density	$f = 1kHz$		2.6		$pA/\sqrt{Hz}$
$i_{NIERR rms}$	0.1 to 10Hz Total Internal rms Noise Current	$f = 0.1$ to 10Hz		4		$pArms$
-3dB BW	-3dB Bandwidth vs. Closed Loop Gain, $R_{FB} = 30.1k$	$R_{FB} = 30.1k\Omega$ ; $R_{IN} = 301k\Omega$ ; $G = 0.1$		5.5		MHz
		$R_{FB} = 30.1k\Omega$ ; $R_{IN} = 30.1k\Omega$ ; $G = 1$		2.6		MHz
		$R_{FB} = 30.1k\Omega$ ; $R_{IN} = 3.01k\Omega$ ; $G = 10$		2.2		MHz
		$R_{FB} = 30.1k\Omega$ ; $R_{IN} = 301\Omega$ ; $G = 100$		2.0		MHz
		$R_{FB} = 30.1k\Omega$ ; $R_{IN} = 30.1\Omega$ ; $G = 1000$		0.3		MHz
-3dB BW	-3dB Bandwidth vs. Closed Loop Gain, $R_{FB} = 121k$	$R_{FB} = 121k\Omega$ ; $R_{IN} = 1.21M\Omega$ ; $G = 0.1$		5.0		MHz
		$R_{FB} = 121k\Omega$ ; $R_{IN} = 121k\Omega$ ; $G = 1$		1.4		MHz
		$R_{FB} = 121k\Omega$ ; $R_{IN} = 12.1k\Omega$ ; $G = 10$		0.5		MHz
		$R_{FB} = 121k\Omega$ ; $R_{IN} = 1.21k\Omega$ ; $G = 100$		0.45		MHz
		$R_{FB} = 121k\Omega$ ; $R_{IN} = 121\Omega$ ; $G = 1000$		0.4		MHz
SR	Slew Rate			4		$V/\mu s$
$t_S$	Settling Time to 0.01%	$V_{OUT} = \pm 2.4V$ , $R_F = 30.1k\Omega$		3		$\mu s$
		$V_{OUT} = \pm 9.6V$ , $R_F = 121k\Omega$		11		$\mu s$

**NOTES:**

- Compliance to datasheet limits is assured by one or more methods: production test, characterization and/or design.
- Differential Gain ( $A_V$ ) =  $R_{FB}/R_{IN}$ .
- $\pm V_{OUT}$ , clipping  $\sim I_{RF} * R_{FB}$ .
- $V_{OS,OUT} = A_V * V_{OS,IN} + V_{OS,FB} + I_{ERR} * R_{FB}$ .
- Compliance to datasheet limits is assured by Design simulation.

**Typical Performance Curves**

$V_{CC} = V_{CO} = 15V$ ,  $V_{EE} = V_{EO} = -15V$ ,  $V_{CM} = 0V$ ,  $R_L = \text{Open}$ , unless otherwise specified.

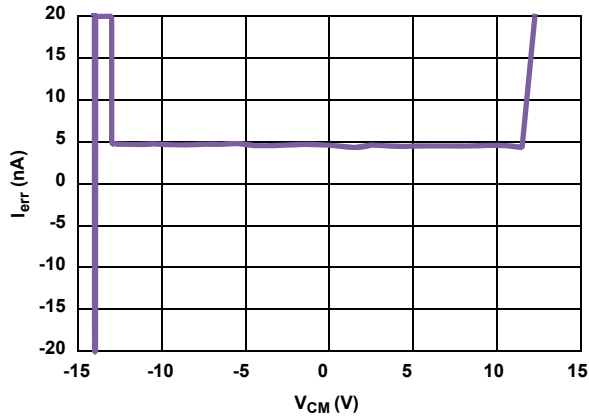

FIGURE 3.  $I_{ERR}$  vs INPUT COMMON MODE VOLTAGE

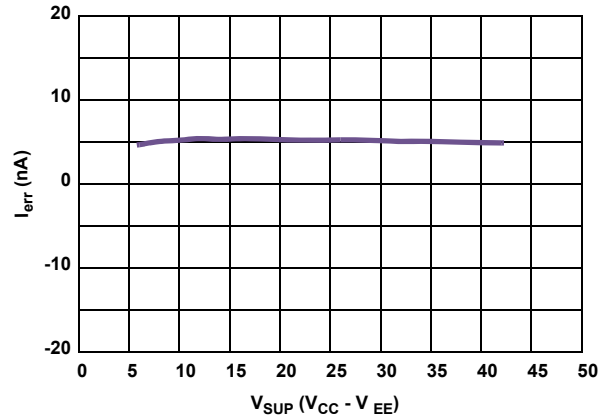

FIGURE 4.  $I_{ERR}$  vs SUPPLY VOLTAGE ( $V_{CC} - V_{EE}$ )

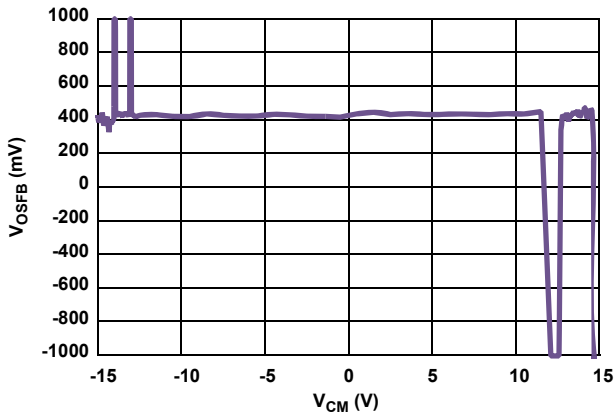

FIGURE 5.  $V_{OSFB}$  vs INPUT COMMON MODE VOLTAGE

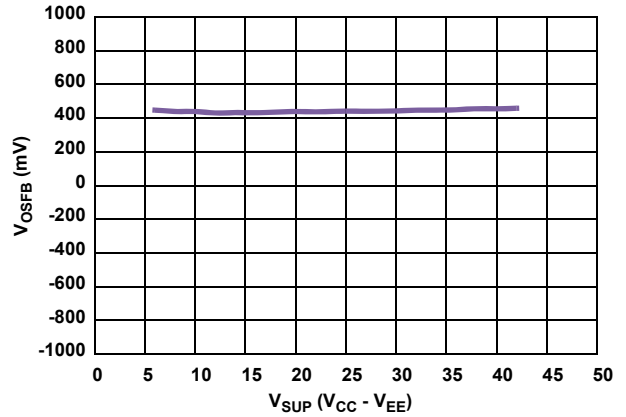

FIGURE 6.  $V_{OSFB}$  vs SUPPLY VOLTAGE ( $V_{CC} - V_{EE}$ )

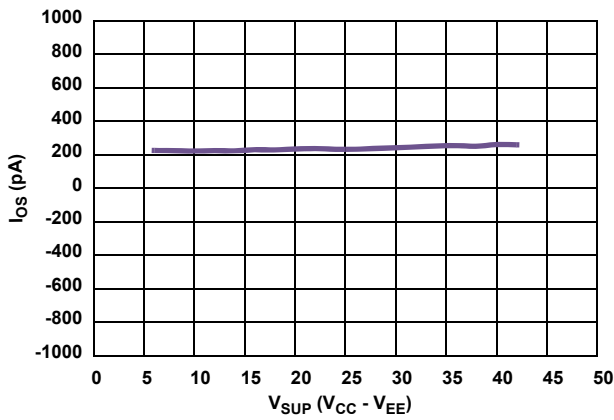

FIGURE 7.  $I_{OS}$  vs SUPPLY VOLTAGE ( $V_{CC} - V_{EE}$ )

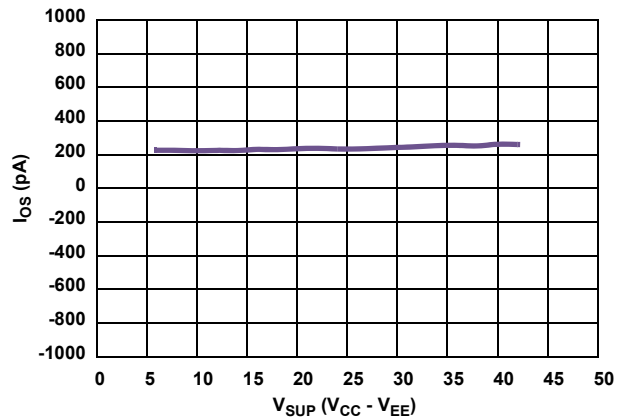

FIGURE 8.  $I_{OS}$  vs SUPPLY VOLTAGE ( $V_{CC} - V_{EE}$ )

## Typical Performance Curves

$V_{CC} = V_{CO} = 1.5V$ ,  $V_{EE} = V_{EO} = -1.5V$ ,  $V_{CM} = 0V$ ,  $R_L = \text{Open}$ , unless otherwise specified.

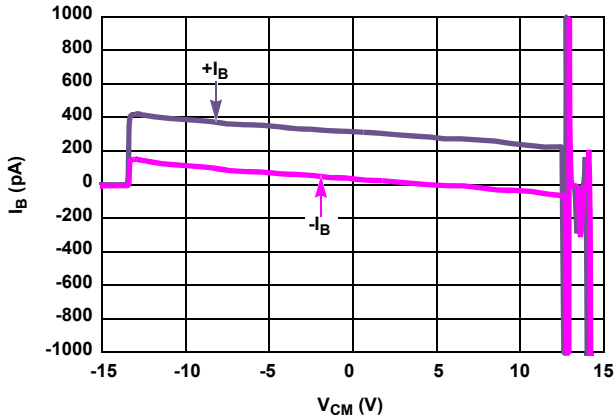

FIGURE 9.  $I_B$  vs INPUT COMMON MODE VOLTAGE

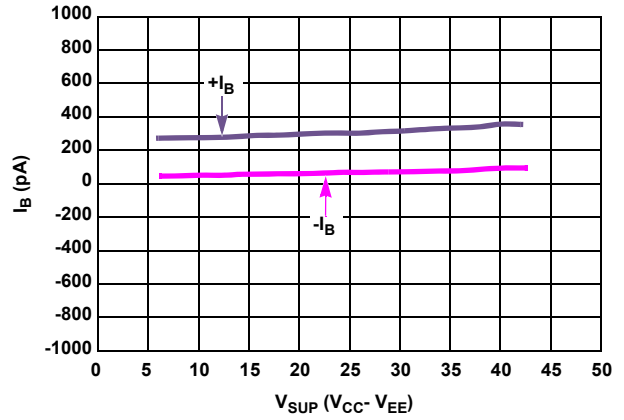

FIGURE 10.  $I_B$  vs SUPPLY VOLTAGE ( $V_{CC} - V_{EE}$ )

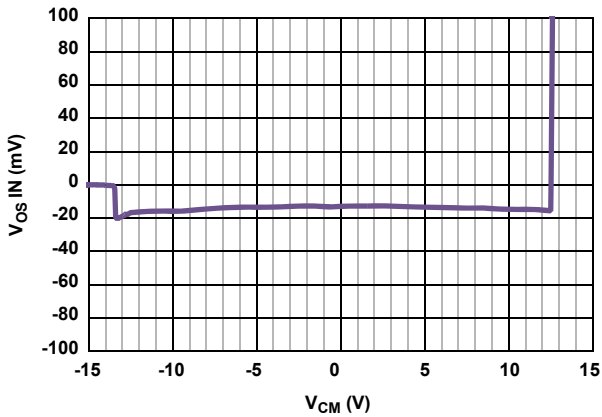

FIGURE 11.  $V_{OSIN}$  vs INPUT COMMON MODE VOLTAGE

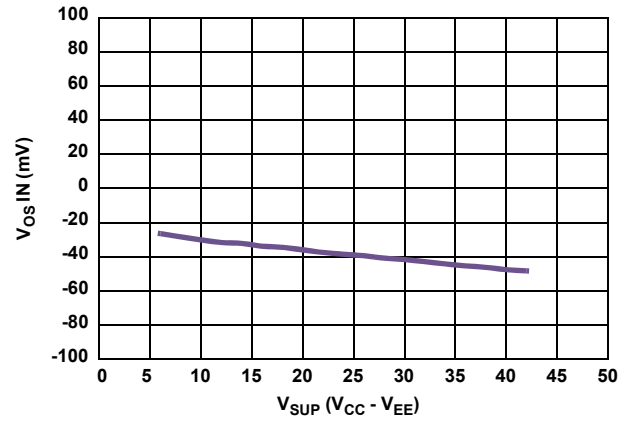

FIGURE 12.  $V_{OSIN}$  vs SUPPLY VOLTAGE ( $V_{CC} - V_{EE}$ )

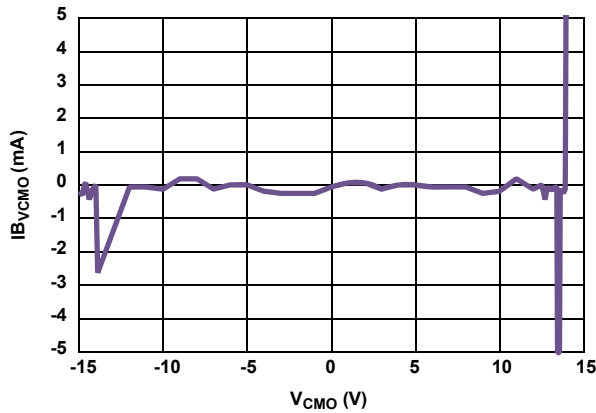

FIGURE 13.  $I_{B_{VCMO}}$  vs  $V_{CMO}$  INPUT VOLTAGE RANGE

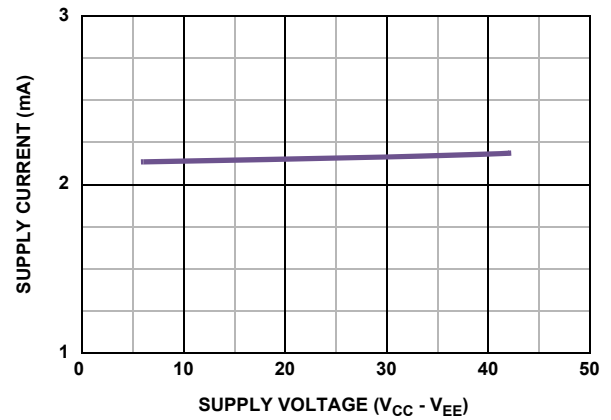

FIGURE 14.  $I_{CC}$  vs SUPPLY VOLTAGE ( $V_{CC} - V_{EE}$ )



Typical Performance Curves

$V_{CC} = V_{CO} = 1.5V$ ,  $V_{EE} = V_{EO} = -1.5V$ ,  $V_{CM} = 0V$ ,  $R_L = \text{Open}$ , unless otherwise specified.

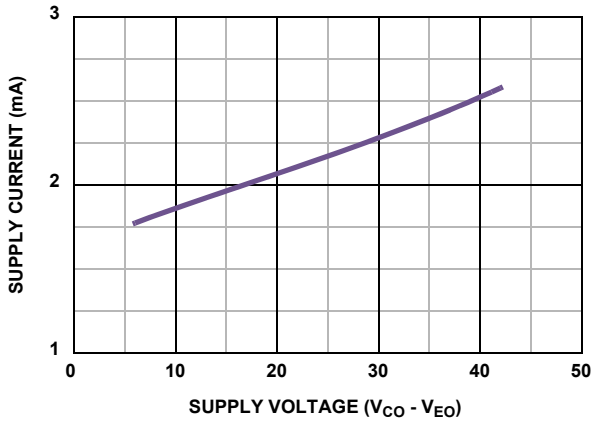

FIGURE 15.  $I_{CO}$  vs SUPPLY VOLTAGE ( $V_{CO} - V_{EO}$ )

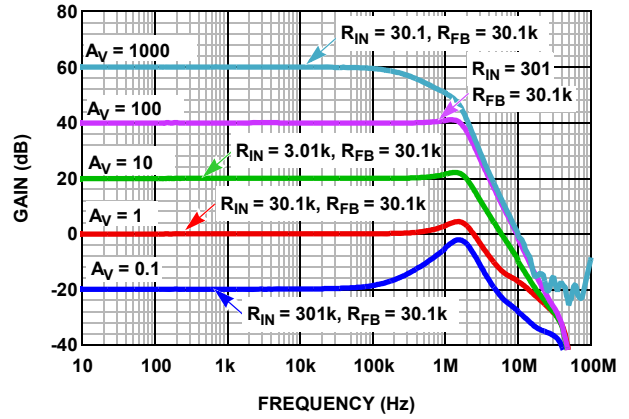

FIGURE 16. CLOSED LOOP GAIN ( $R_{FB} = 30.1k$ ) vs FREQUENCY

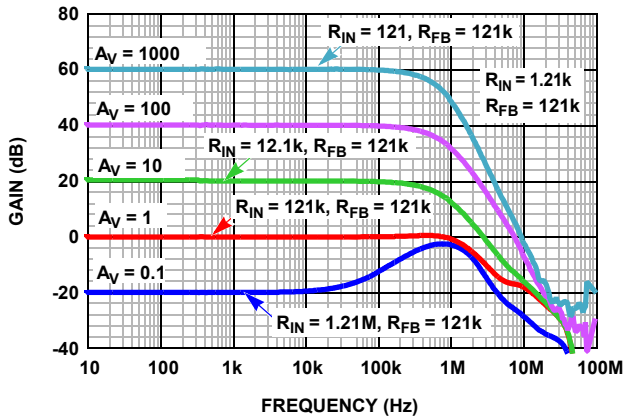

FIGURE 17. CLOSED LOOP GAIN ( $R_{FB} = 121k$ ) vs FREQUENCY

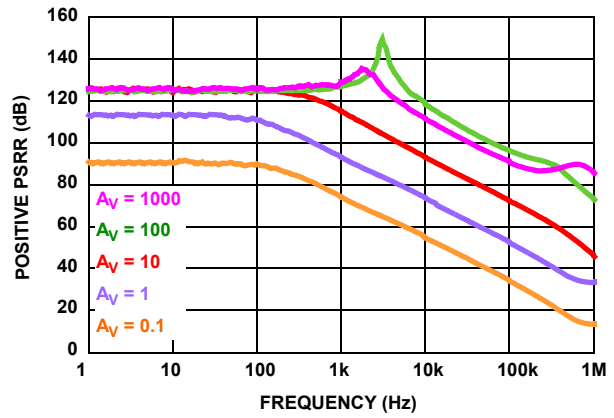

FIGURE 18. POSITIVE PSRR  $V_{EE}$  &  $V_{CC}$  ( $R_F = 30.1k$ )

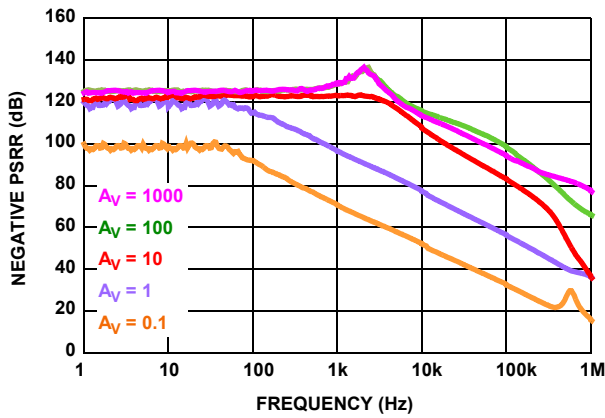

FIGURE 19. NEGATIVE PSRR  $V_{EE}$  &  $V_{CC}$  ( $R_F = 30.1k$ )

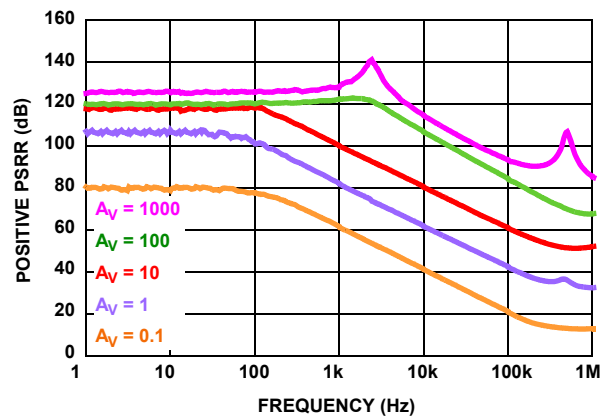

FIGURE 20. POSITIVE PSRR  $V_{EE}$  &  $V_{CC}$  ( $R_F = 121k$ )

Typical Performance Curves

$V_{CC} = V_{CO} = 1.5V$ ,  $V_{EE} = V_{EO} = -1.5V$ ,  $V_{CM} = 0V$ ,  $R_L = \text{Open}$ , unless otherwise specified.

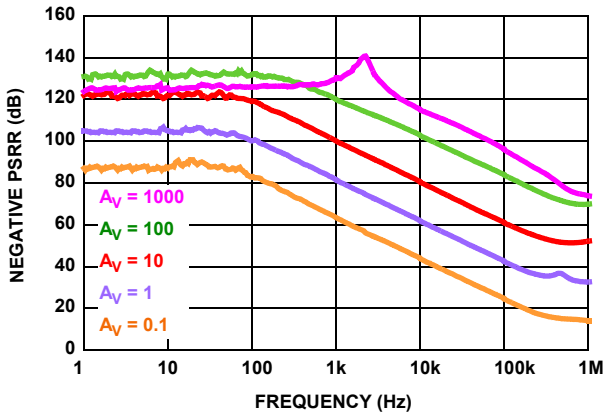

FIGURE 21. NEGATIVE PSRR  $V_{EE}$  &  $V_{CC}$  ( $R_F = 121k$ )

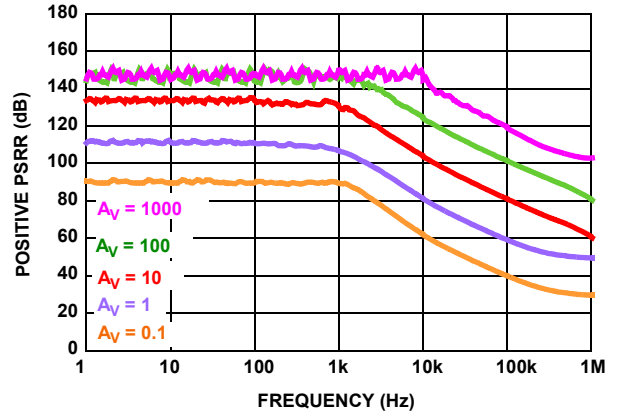

FIGURE 22. POSITIVE PSRR  $V_{EO}$  &  $V_{CO}$  ( $R_F = 30.1k$ )

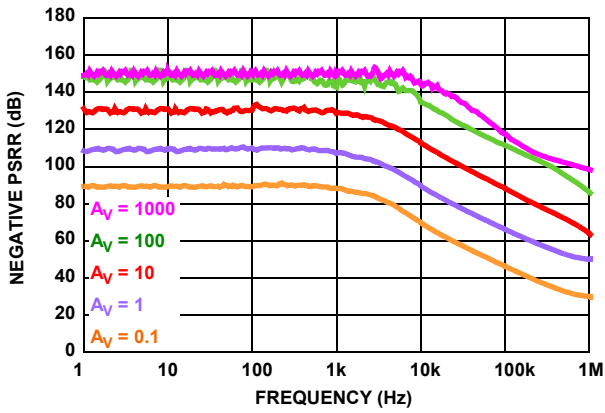

FIGURE 23. NEGATIVE PSRR  $V_{EO}$  &  $V_{CO}$  ( $R_F = 30.1k$ )

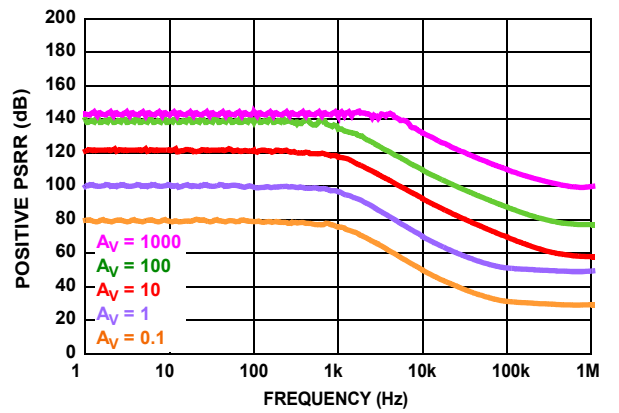

FIGURE 24. POSITIVE PSRR  $V_{EO}$  &  $V_{CO}$  ( $R_F = 121k$ )

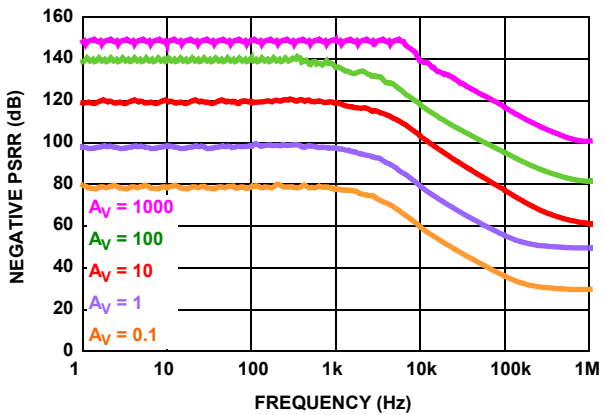

FIGURE 25. NEGATIVE PSRR  $V_{EO}$  &  $V_{CO}$  ( $R_F = 121k$ )

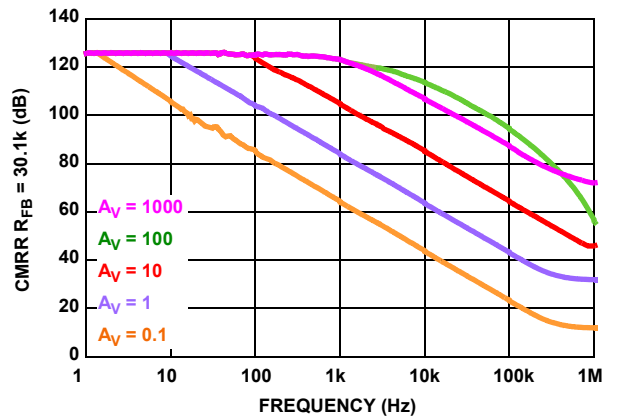

FIGURE 26. CMRR  $R_F = 30.1k$

## Typical Performance Curves

$V_{CC} = V_{CO} = 1.5V$ ,  $V_{EE} = V_{EO} = -1.5V$ ,  $V_{CM} = 0V$ ,  $R_L = \text{Open}$ , unless otherwise specified.

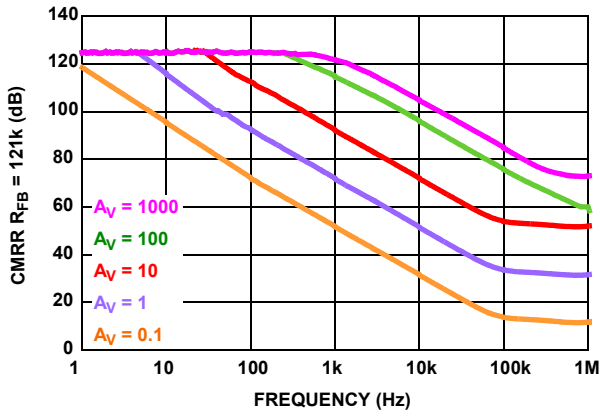

FIGURE 27. CMRR  $R_{FB} = 121k$

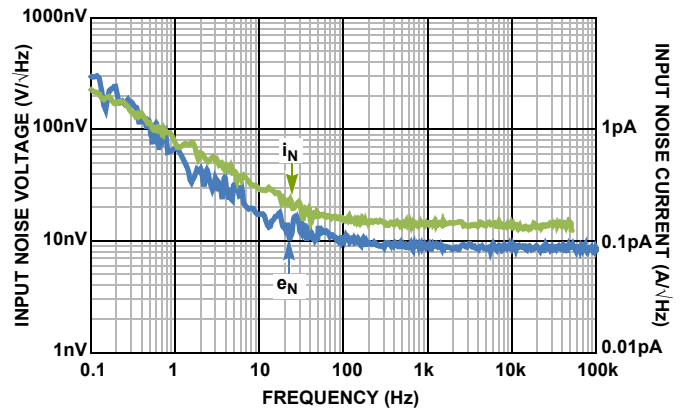

FIGURE 28. INPUT VOLTAGE AND CURRENT NOISE

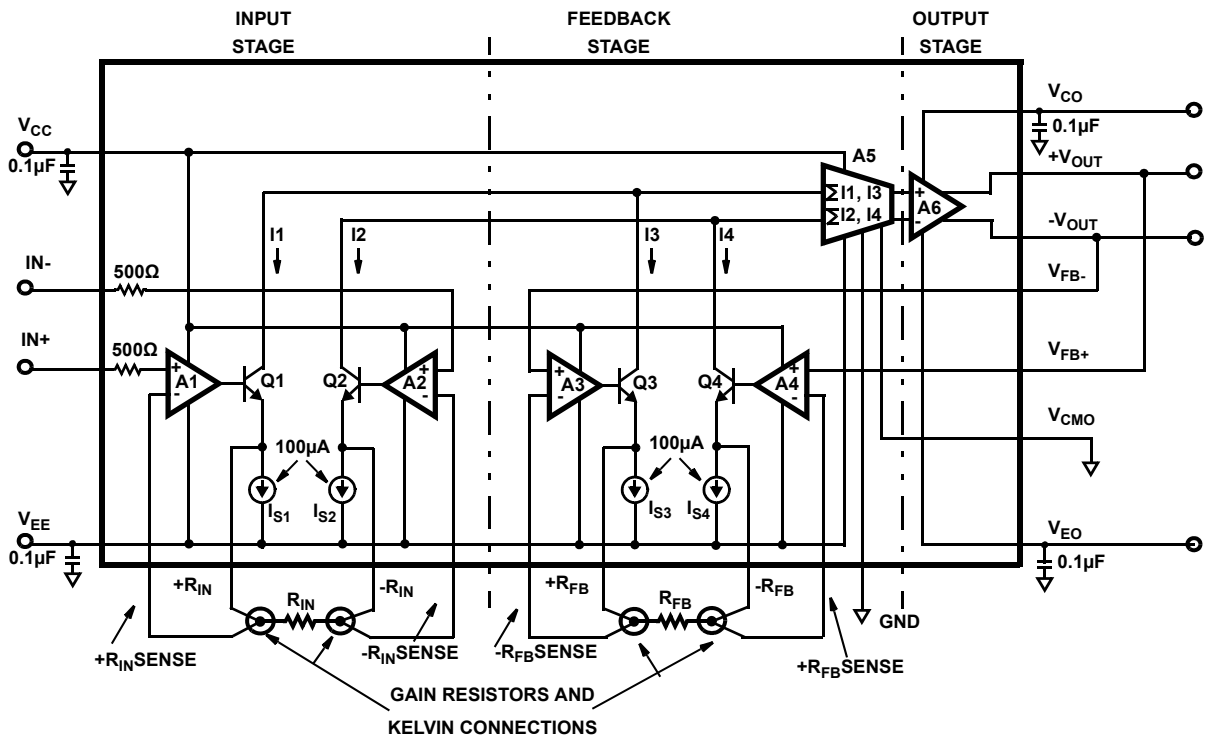

FIGURE 29. ISL28617 FUNCTIONAL BLOCK DIAGRAM

## Applications Information

Section 1 contains the ISL28617 functional and performance objectives and description of operation.

Section 2 contains the application circuit design equations and guidelines for achieving the desired DC and AC performance levels.

Section 3 provides equations for predicting DC offset voltage and noise of the finished design.

### 1. General Description

The ISL28617 Instrumentation Amplifier was developed to accomplish the following:

- Provide a fully differential, rail-to-rail output for optimally driving ADCs.
- Limit the output swing to prevent output overdrive.
- Allow any gain, including attenuation.
- Maximize gain accuracy by removing on-chip component tolerances and external PC board parasitic resistance.
- Enable user control of amplifier precision level with choice of external resistor tolerance.
- Maintain CMRR > 100dB and remove CMRR sensitivity to gain resistor tolerance.
- Provide a level shift interface from bipolar analog input signal sources to unipolar, and bipolar ADC output terminations.

### Functional Description (Figure 29)

Figure 29 shows the functional block diagram for the ISL28617.

#### Input $G_M$ Amplifier

The input stage consists of high performance, wide band amplifiers A1, A2,  $G_M$  drive transistors Q1, Q2, and input gain resistor  $R_{IN}$ . Current drive for Q1 and Q2 emitters are provided by matched pair of  $100\mu A$  current sinks. A unity gain buffer from each input (IN+, IN-) to the terminals of the input resistor,  $R_{IN}$ , is formed by the connection of the Kelvin resistor sense pins and drive pins to the terminals of the input resistor, as shown in Figure 29. In this configuration, the voltage across the input resistor  $R_{IN}$  is equal to the input differential voltage across IN+ and IN-.

The input  $G_M$  stage operates by creating a current difference in the collector currents Q1 and Q2 in response to the voltage difference between the IN+ and IN- pins. When the input voltage applied to the IN+ and IN- pins is zero, the voltage across the terminals of the gain resistor  $R_{IN}$ , is also zero. Since there is no current flow through the gain resistor, the transistors Q1, and Q2 collector currents I1, I2 are equal.

A change in the input differential voltage causes an equivalent voltage drop across the input gain resistor  $R_{IN}$ , and the resulting current flow through  $R_{IN}$ , causes an imbalance in Q1, Q2 collector currents I1, I2, given by:

$$I_1 = 100\mu A + (V_{IN+} - V_{IN-})/R_{IN} \quad (EQ. 1)$$

$$I_2 = 100\mu A - (V_{IN+} - V_{IN-})/R_{IN} \quad (EQ. 2)$$

#### Feedback $G_M$ Amplifier

The feedback amplifiers A3, A4 form a differential trans conductance amplifier identical to the input stage. The input terminals ( $V_{FB+}$ ,  $V_{FB-}$ ) connect to the ISL28617 differential output terminals ( $+V_{OUT}$ ,  $-V_{OUT}$ ) so that the output voltage also appears across the feedback gain resistor  $R_{FB}$ .

Operation is the same as the input  $G_M$  stage and the differential currents I3, I4 are given by:

$$I_3 = 100\mu A - \{(+V_{OUT}) - (-V_{OUT})\}/R_{FB} \quad (EQ. 3)$$

$$I_4 = 100\mu A + \{(+V_{OUT}) - (-V_{OUT})\}/R_{FB} \quad (EQ. 4)$$

#### Error Amplifier A5, Output Amplifier A6 (Figure 29)

Amplifiers A5 and A6 act together to form a high gain, differential I/O trans-impedance amplifier. Differential current amplifier A5 sums the differential currents (I1+I3, I2+I4) from the input and feedback  $G_M$  amplifiers. From that summation, a differential error voltage is sent to A6, which generates the rail-to-rail differential output drive to the  $+V_{OUT}$  and  $-V_{OUT}$  pins.

The external connection of the output pins to the feedback amplifier closes a servo loop where a change in the differential input voltage is converted into differential current imbalances at I1, I2 (Equations 1, 2) at the summing node inputs to A5. Current I1 sums with current I3 from the feedback stage, and I2 sums with I4. A5 senses the difference between current pairs I1, I3 and I2, I4. A difference voltage is generated, amplified and fed back to the feedback amplifier, which creates correction currents at I3, I4 to match the currents at I1, I2 (Equations 3, 4).

Therefore, at equilibrium:

$$I_1 = I_3 \text{ and } I_2 = I_4 \quad (EQ. 5)$$

Combining Equations 1 and 3, (and their complements I2 and I4), and solving for  $V_{OUT}$  as a function of  $V_{IN}$ ,  $R_{IN}$  and  $R_{FB}$ , yields Equation 6:

$$V_{OUT} = V_{IN} * R_{FB}/R_{IN} ; \quad (EQ. 6)$$

Where  $V_{OUT} = (+V_{OUT}) - (-V_{OUT})$  and  $V_{IN} = IN+ - IN-$

Equation 6 can be rearranged to form the gain Equation 7:

$$\text{Gain} = V_{OUT}/V_{IN} = R_{FB}/R_{IN} \quad (EQ. 7)$$

which is general form of the gain Equation for the ISL28617.

## 2. Designing with the ISL28617

To complete a working design, the following procedure is recommended and explained in this section:

1. Define the output voltage swing.
2. Set the feedback resistor value,  $R_{FB}$
3. Set the input gain resistor value,  $R_{IN}$
3. Set the  $V_{CO}$ ,  $V_{EO}$  power supply voltages
4. Set the  $V_{CC}$  and  $V_{EE}$  supply voltages

The gain of the instrumentation amplifier is set by the resistor ratio  $R_{FB}/R_{IN}$  (Equation 7), and the maximum output swing is set by the absolute value of the feedback resistor  $R_{FB}$  (Equation 8).  $V_{CO}$  and  $V_{EO}$  supply power to the rail-to-rail output stage and define the maximum output voltage swing at the  $\pm V_{OUT}$  differential output pins. Power supply pins  $V_{CC}$  and  $V_{EE}$  power the feedback amplifiers which, require an additional  $\pm 3V$  beyond the  $V_{CO}$  and  $V_{EO}$  voltages to maintain linear operation of the feedback  $G_M$  stage.

## Setting the Feedback Gain Resistor $R_{FB}$ (Figures 29, 30)

Resistor  $R_{FB}$  defines the maximum differential voltage at output terminals  $+V_{OUT}$  to  $-V_{OUT}$ . External resistor  $R_{FB}$  and the differential  $100\mu A$  current sources define the maximum dynamic range of the feedback stage, which defines the maximum differential output swing of the output stage. Overload circuitry allows  $>100\mu A$  to flow through  $R_{FB}$  to maintain feedback, but linearity is degraded. Therefore, it is a good practice to keep the maximum linear dynamic range to within  $\pm 80\%$  of the maximum  $I \cdot R$  across the resistor.

$$V_{OUT\,DIFF} = \pm 80\mu A \cdot R_{FB} \quad (EQ. 8)$$

In cases where large pulse overshoot is expected, the maximum current in Equation 8 could be reduced to 50% for additional margin (See "AC Performance Considerations" on page 15.) The penalty for increasing the feedback resistor value is higher DC offset voltage and noise.

Output voltages that exceed the maximum dynamic range of the feedback amplifier can degrade phase margin and cause instability. The plot in Figure 30 shows the maximum differential output voltage swing vs. resistor value for  $R_{FB}$  and  $R_{IN}$  using the 80% and 50% current source levels.

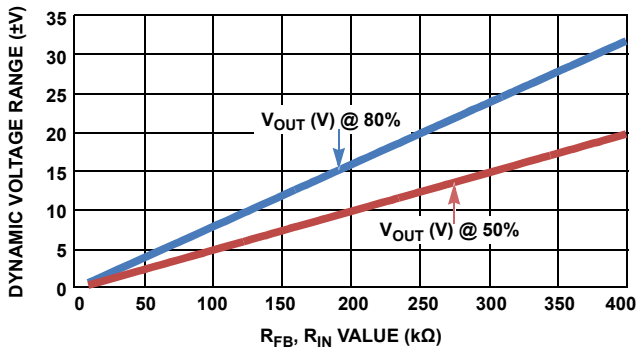

FIGURE 30.  $R_{FB}, R_{IN}$  vs. DYNAMIC RANGE

## Setting the Input Gain Resistor $R_{IN}$ (Figures 29, 30)

The input gain resistor  $R_{IN}$  is scaled to the feedback resistor according to the gain Equation 9:

$$R_{IN} = R_{FB}/Gain \quad (EQ. 9)$$

The input  $G_M$  stage uses the same differential current source arrangement as the feedback stage. Therefore, the amount of overdrive margin (50%, 80%) included in the calculation for  $R_{FB}$  is also included in the calculation for  $R_{IN}$ .

## Input Stage Overdrive Considerations (Figure 31)

There are a few cases where the input stage can be over driven, which must be considered in the application. An input signal that exceeds the maximum dynamic range of the gain resistor  $R_{IN}$ , calculated previously, can cause the ESD diodes to conduct. When this occurs, a low impedance path from the inputs to the input gain resistor  $R_{IN}$  will result in signal distortion.

High speed input signals that remain within the maximum dynamic range of the input stage can cause distortion if the input slew rate exceeds the input stage slew rate ( $\sim 4V/\mu s$ ). When the input slews at a faster rate than the  $G_M$  stage can follow, the voltage difference appears across the input ESD diodes from each input and resistor  $R_{IN}$ . When the voltage difference is large enough to cause the diodes to conduct, the input terminals are shunted to  $R_{IN}$  through the  $500\Omega$  input protection resistors, causing distortion during the rise and fall times of the transient pulse. The distortion will last until the resistor voltage catches up to the input voltage.

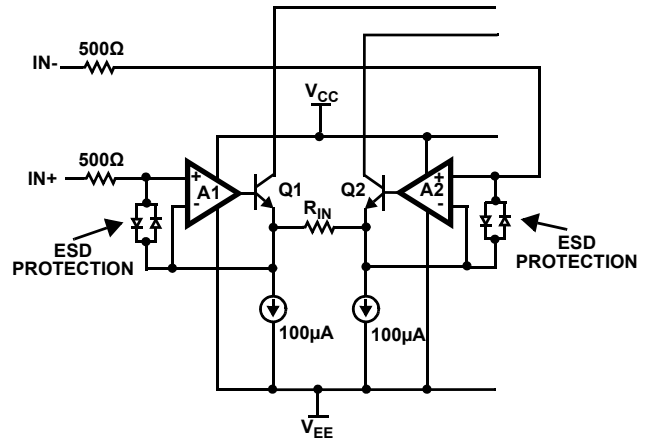

FIGURE 31. INPUT STAGE ESD PROTECTION DIODES

## Setting the Power Supply Voltages

The ISL28617 power supplies are partitioned so that the input stage and feedback stages are powered from a separate pair of supply pins ( $V_{CC}, V_{EE}$ ) than the differential output stage ( $V_{CO}, V_{EO}$ ). This partitioning provides the user with the ability to adapt the ISL28617 to a wide variety of input signal power sources that would not be possible if the supplies were strapped together internally ( $V_{CC} = V_{CO}$  &  $V_{EE} = V_{EO}$ ). However, powering the input and output supplies from unequal supplies has restrictions that are described in the next section.

## Powering the Input and Feedback Stages ( $V_{CC}, V_{EE}$ )

The input pins  $IN+$ ,  $IN-$  cannot swing rail-to-rail, but have a maximum input voltage range given by Equation 10:

$$V_{EE} + 3V \leq (V_{CMIRIN} + V_{IN}) \leq V_{CC} - 3V; \quad (EQ. 10)$$

where  $V_{IN}$  = maximum differential voltage  $IN+$  to  $IN-$

This requires the sum of the common mode input voltage and the differential input voltage to remain within 3V of either the  $V_{CC}$  or  $V_{EE}$  rail, otherwise distortion will result.

The feedback pins  $V_{FB+}$  and  $V_{FB-}$  have the same input common mode voltage constraint as the input pins  $IN+$ ,  $IN-$ . The maximum input voltage range of the feedback pins is given by Equation 11:

$$V_{EE} + 3V \leq V_{CMIRFB} \leq V_{CC} - 3V \quad (\text{EQ. 11})$$

where  $V_{CMIRFB} = (+V_{OUT} - -V_{OUT}) + V_{CMO}$

To maintain stability, it is critical to respect the  $\pm 3V$  requirement in Equation 11.

## Powering the Rail-to-rail Output Stage ( $V_{CO}$ , $V_{EO}$ )

The output stage (A6) is of rail-to-rail design, and is powered by the  $V_{CO}$  and  $V_{EO}$  pins. The differential output pins  $+V_{OUT}$ ,  $-V_{OUT}$  connect to the  $V_{FB+}$ ,  $V_{FB-}$  pins to close the output feedback loop. The feedback stage is powered from  $V_{CC}$  and  $V_{EE}$  pins. The  $V_{FB+}$ ,  $V_{FB-}$  have a common mode input range 3V below the  $V_{CC}$  rail and 3V above the  $V_{EE}$  rail. If the output voltage exceeds the feedback common mode input voltage, loop instability will result. Therefore, the voltages at the  $\pm V_{OUT}$  pins should always be 3V away from either rail, as shown in Equation 12.

$$V_{EE} + 3V \leq V_{OUT} \leq V_{CC} - 3V; \quad (\text{EQ. 12})$$

where  $V_{OUT} = | +V_{OUT} |$  or  $| -V_{OUT} |$

## Rail-to-rail Differential ADC Driver

The differential output stage of the ISL28617 is designed to drive the differential input stage of an ADC. In this configuration, the  $V_{CO}$ ,  $V_{EO}$  power supply pins connect directly to the ADC power supply pins. This output swing arrangement is ideal for driving rail-to-rail ADC drive without the possibility of over driving the ADC input.

The output stage is capable of rail-to-rail operation when  $V_{CO}$ ,  $V_{EO}$  are powered from a single supply or from split supplies. It has a single supply voltage range ( $V_{CO}$ ) from 3V to 15V (with  $V_{EO}$  at GND), and a  $\pm 1.5V$  to  $\pm 15V$  split supply voltage range. Under all power supply conditions,  $V_{CC}$  must be greater than  $V_{CO}$  by 3V, and  $V_{EE}$  must be less than  $V_{EO}$  by 3V to maintain the rail-to-rail output drive capability.

The  $V_{CMO}$  pin is an input to a very low bias current terminal, and sets the output common mode reference voltage when driving a differential input ADC, such that the output would have a  $\pm$  input signal span centered around an external DC reference voltage applied to the  $V_{CMO}$  pin.

## Power Supply Voltages by Application

The ISL28617 can be adapted to a wide variety of instrumentation amplifier applications where the signal source is powered from supply voltages that are different from the supply voltages powering downstream circuits. The following examples are included as a guide to the proper connection and voltages applied to the supply pins  $V_{CC}$ ,  $V_{EE}$ ,  $V_{CO}$  and  $V_{EO}$ .

There are a common set of requirements across all power applications:

1. A common ground connection from the input supplies, ( $V_{CC}$ ,  $V_{EE}$ ) to the output supplies ( $V_{CO}$ ,  $V_{EO}$ ) is required for all powering options.
2. The signal input pins  $IN+$ ,  $IN-$  cannot float, and must have a DC return path to ground.
3. The input and output supplies cannot both be operated in single supply mode due to the 3V feedback amplifier common mode headroom requirement in Equation 11.

The following are typical power examples:

### EXAMPLE 1: BIPOLAR INPUT TO SINGLE SUPPLY OUTPUT

The ISL28617 is configured as a 5V ADC driver in a high gain sensor bridge amplifier powered from a  $\pm 10V$  excitation source. In this application, the ISL28617 must extract the low level bipolar sensor signal and shift the level to the 0V to +5V differential rail-to-rail signal needed by the ADC. The following powering option is recommended:

- $V_{CC} = +10V$ ,  $V_{EE} = -10V$
- $V_{CO} = +5V$ ,  $V_{EO} = GND$
- $V_{CMO} = +2.5V$
- $V_{CC}$ ,  $V_{EE}$  power supply common connects to GND

### EXAMPLE 2: HIGH VOLTAGE BIPOLAR I/O BUFFER

The ISL28617 is configured as a high impedance buffer instrumentation amplifier in a  $\pm 15V$  industrial sensor application. In this application, the ISL28617 must extract and amplify the high impedance sensor signal and send it downstream to a differential ADC operating from  $\pm 15V$  supplies. The following powering options are recommended:

1. Input and output supplies are strapped to the same supplies and rail-to-rail input to the ADC is not required.
  - $V_{CC} = V_{CO} = +15V$
  - $V_{EE} = V_{EO} = -15V$
  - $V_{CMO} = GND$
  - $V_{CC}$ ,  $V_{EE}$  power supply common connects to GND and  $V_{OUT} = \pm 12V$ .
2.  $\pm 15V$  Rail-to-rail output is required, then:
  - $V_{CC} = +18V$ ,  $V_{EE} = -18V$
  - $V_{CO} = +15V$ ,  $V_{EO} = -15V$
  - $V_{CMO} = GND$
  - $V_{CC}$ ,  $V_{EE}$  power supply common connects to GND

The  $V_{CO}$  and  $V_{EO}$  power supply pins connect to the ADC  $\pm 15V$  power supply pins. Rail-to-rail output swing requires that  $V_{CC} = V_{CO} + 3V$  and  $V_{EE} = V_{EO} - 3V$ , or  $\pm 18V$ .

## EXAMPLE 3: GAINS LESS THAN 1

The ISL28617 is configured to a gain of 0.2V/V driving a rail-to-rail 3V ADC. In this application, the maximum input dynamic range is  $\pm 15V$ .

- $V_{CC} = +18V$ ,  $V_{EE} = -18V$
- $V_{CO} = +3V$ ,  $V_{EO} = GND$
- $V_{CMO} = +1.5V$
- $V_{CC}$ ,  $V_{EE}$  power supply common connects to GND

In this attenuator configuration, the input signal range is  $\pm 15V$ , which requires an additional  $\pm 3V$  of input overhead from the input supplies. Thus,  $V_{CC}$  and  $V_{EE} = \pm 18V$ .

## AC Performance Considerations

The ISL28617 closed loop frequency response is formed by the feedback  $G_M$  amplifier and gain resistor  $R_{FB}$  and has the characteristics of a current feedback amplifier. Therefore, the -3dB gain does not significantly decrease at high gains as is the case with the constant gain-bandwidth response of the classic voltage feedback amplifier.

There are four behaviors of current feedback amplifiers that must be considered:

- Frequency response increases with decreasing values of  $R_{FB}$ . A comparison of the  $G = 100$ , -3db response (Figures 16, 17)  $R_{FB}$  at 30.1k $\Omega$  vs. 121k $\Omega$  shows almost a 4X decrease from 2MHz to 0.5MHz.
- Gain peaking tends to increase with decreasing values of  $R_{FB}$
- Wide band applications at gains less than 1 (Figures 16, 17) can have high gain peaking resulting in high levels of overshoot with pulsed input signals
- Parasitic capacitance at the feedback resistor terminals ( $+R_{FB}$ ,  $-R_{FB}$ ) and the Kelvin sense terminals ( $+R_{FB}SENSE$ ,  $-R_{FB}SENSE$ ) will result in increasing levels of peaking and transient response overshoot.

To minimize peaking external PC parasitic capacitance should be minimized as much as possible. The ISL28617 is designed to be stable with PC board parasitic capacitance up to 20pF and feedback resistor values down to 30.1k $\Omega$ . At gains less than 1, the maximum parasitic capacitance may have to be limited further to avoid additional compensation.

Uncorrected gain peaking and high overshoot in the feedback stage can cause loss of feedback loop stability if the transient causes the feedback voltage to exceed the common mode input range of the feedback amplifier or the maximum linear range of the feedback resistor  $R_{FB}$ . Corrective actions include increasing the size of the feedback resistor (see Figure 30) and re-scaling the input gain resistor  $R_{IN}$ , or adding input frequency compensation described in the next section.

The penalty of increasing the  $R_{FB}$  (and  $R_{IN}$  re-scaling) is increased noise, so this is generally not the corrective action of choice

## AC Compensation Techniques

Input compensation with a low pass filter (Figure 32) can be an effective way to block high frequency signals from the differential amplifier inputs. It does not change the gain peaking behavior of the feedback loop, but it does block signals from

creating overdrive instability. This method is useful after other corrective measures have been implemented, and when there is little control over the input signal frequency content.

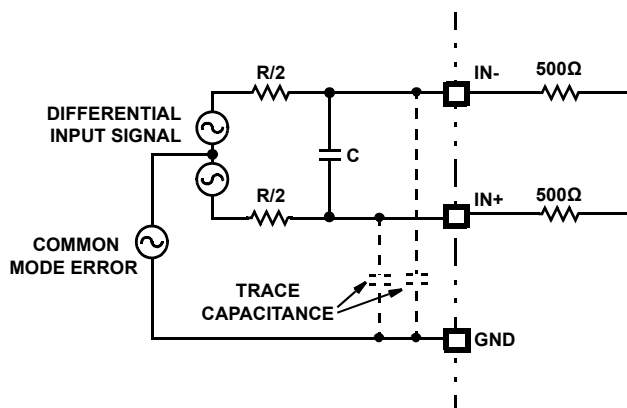

FIGURE 32. INPUT DIFFERENTIAL LOW PASS FILTER AND PARASITIC CAPACITANCE

## Input Common Mode Rejection Considerations

The ISL28617 is capable of a very high level (120dB) of CMRR performance from DC to as high as 1kHz. (Figure 1; CMRR vs. Frequency). This high level of performance over frequency is made possible by the high common mode input impedance (80G $\Omega$ ) but requires careful attention to the matching of the IN+ and IN- external impedances to GND.

A mismatch in the series impedance in conjunction with parasitic capacitance at the IN+, IN- terminals (Figure 32) will cause a common mode amplitude imbalance that will show up as a differential input signal, rapidly degrading CMRR as the common mode frequency increases.

Maximum CMRR performance is achieved with attention to balancing external components and attention to PC layout.

## Layout Guidelines

The ISL28617 is a high precision device with wide band AC performance. Maximizing DC precision requires attention to the layout of the gain resistors. Achieving good AC response requires attention to parasitic capacitance at the gain resistor terminals, and CMRR performance over frequency is ensured with symmetrical component placement and layout of the input differential signals to the IN+ and IN- terminals.

To ensure the highest DC precision, the location of the gain resistors and PC trace connections to the Kelvin connections are most important. Proper Kelvin connections remove trace resistance errors so that the amplifier gain accuracy, and gain temperature coefficients are determined by the gain resistor matching tolerance. Interconnect constraints preclude mounting the gain resistors next to each other, so they should be located on either side of the ISL28617 and as close to the device as possible. The Kelvin connections are formed at the junction of the sense pins ( $\pm R_{IN}SENSE$ ,  $\pm R_{FB}SENSE$ ) and the gain resistor current drive terminals ( $\pm R_{IN}$ ,  $\pm R_{FB}$ ) terminals. This junction should be made at the terminal pads directly under the ends of each resistor.

Reduced trace lengths that maintain DC accuracy are also important for minimizing the capacitance that can degrade AC stability. This is especially true at gains less than 1. Layout techniques for precision applications using larger size precision gain resistors at very low gains ( $G = 0.1V/V$ ) include removing a section of the underlying PC ground plane directly under the gain resistor terminals and body.

Layout guidelines for high CMRR include matching trace lengths and symmetrical component placement on the circuit that connects the signal source to the IN+, IN- pins. This ensures matching of the IN+ and IN- input impedances (Figure 32).

## Power Supply De-coupling

Standard power supply de-coupling consists of a single 0.1μF 50V ceramic capacitor at the power supply terminals located as close to the device as possible. In applications where the input and output supplies are strapped to the same voltage ( $V_{EE} = V_{EO}$ ,  $V_{CC} = V_{CO}$ ) the connection point should be as close to the device as possible, with a single 0.1μF 50V ceramic capacitor at the junction. Applications using separate supplies require 0.1μF 50V ceramic de-coupling capacitors at each power supply terminal.

## 3. Estimating Amplifier DC and Noise Performance

The gain resistor ohmic values and ratios are all that is required to estimate DC offset and noise. The following sections illustrate methods to calculate DC offset and noise performance. These estimates are useful for optimizing resistor values for noise and DC offset.

### Calculating DC Offset Voltage

Output offset voltage, like output noise, has several contributors. Also similar to output noise, the major offset contributor depends on the gain configuration. In high-gain,  $V_{OS(I)}$  dominates, while in low-gain, offset due to  $I_{ERR}$  dominates.

The summation of DC offsets to arrive at total DC offset error is performed in two ways. Equation 13 is a simple addition of the DC offsets appearing at the output, and is useful when defining the minimum to maximum range of offset that can be expected. The drawback is that the result defines the corner of the corners

of the error box, and not a typical value given that these sources are uncorrelated.

$$V_{OS(RTO)} = [(A_V \times V_{OS(I)} + (V_{OS(FB)} + (I_{ERR} \times R_{FB}))] \quad (EQ. 13)$$

Equation 14 expresses the total DC error as the rms, or square root of the sum of the squares to provide an estimate of a typical value.

$$V_{OS(RTO)TYP} = \sqrt{[(A_V \times V_{OS(I)})^2 + (V_{OS(FB)})^2 + (I_{ERR} \times R_{FB})^2]} \quad (EQ. 14)$$

Equation 15 converts the output offset error (Equation 13) range (Equation 13) to an input referred error range [ $V_{OS(RTI)}$ ] and enables a comparison with the DC component of the input signal.

$$V_{OS(RTI)} = [(V_{OS(I)} + (V_{OS(FB)}/A_V) + (I_{ERR} \times R_{FB})/A_V] \quad (EQ. 15)$$

Similarly, Equation 16 shows the typical DC offset value (Equation 14) referred to the input.

$$V_{OS(RTI)TYP} = \sqrt{[V_{OS(I)}^2 + (V_{OS(FB)}/A_V)^2 + (I_{ERR} \times R_{FB})/A_V]^2} \quad (EQ. 16)$$

These results are summarized in Table 1.

### Calculating Noise Voltage

The calculation of noise spectral density at the output [ $e_N(RTO)$ ] from all noise sources is given by Equation 17. Equation 18

$$e_N(RTO) = \sqrt{[(A_V \times e_N(I))^2 + (2 \times A_V \times i_N(I) \times 500\Omega)^2 + (A_V)^2 \times (4kT \times R_{IN}) + (4kT \times R_{FB}) + (R_{FB} \times i_N(I_{ERR}))^2 + (e_N(FB))^2]} \quad (EQ. 17)$$

converts the output noise to the input referred value when evaluating the input signal to noise ratio.

$$e_N(RTI) = e_N(RTO)/A_V \quad (EQ. 18)$$

Table 2 provides examples of the noise contribution of each source by circuit gain and output voltage span.

In a high-gain configuration, the input noise is the dominant noise source. In a low-gain configuration, the noise voltage from the product of the internal noise current,  $I_{N(Err)}$ , and the feedback resistor,  $R_{FB}$  dominates. The contribution of the internal noise current,  $I_{N(Err)}$  increases in proportion to  $R_{FB}$ , but the corresponding increase in output voltage with  $R_{FB}$  keeps the ratio of this noise voltage to output voltage constant.

TABLE 1. COMPUTING TYPICAL OUTPUT OFFSET VOLTAGE RANGES

$A_V$	$V_{O(LIN)}$	$R_{IN}$ (kΩ)	$R_{FB}$ (kΩ)	$A_V \times V_{OS(I)}$ (μV) (Note 10)	$V_{OS(FB)}$ (μV) (Note 10)	$I_{ERR}$ (5nA) $\times R_{FB}$ (μV) (Note 10)	EQ. 13 $V_{OS(RTO)}$ (μV)	EQ. 15 $V_{OS(RTI)}$ (μV)	EQ. 14 TYPICAL $V_{OS(RTO)}$ (μV)	EQ. 16 TYPICAL $V_{OS(RTI)}$ (μV)
1	±2.5	30	30	±30	±400	±150	±580		428	
1	±10	120	120	±15	±400	±600	±1015		721	
100	±2.5	0.3	30	±1500	±400	±150	±2000	±20	1560	15.6
100	±10	1.2	120	±1500	±400	±600	±2500	±25	1669	16.7

NOTE:

10. Chosen for illustration purposes and does not reflect actual device performance.



# ISL28617

TABLE 2. 1kHz INPUT NOISE AND THERMAL NOISE CONTRIBUTIONS

$A_V$	$R_{IN}$ (k $\Omega$ )	$R_{FB}$ (k $\Omega$ )	$A_V \times e_N(I)$ (nV/ $\sqrt{Hz}$ )	$2 \times A_V \times I_{N(I)}$ $\times 500\Omega$ (nV/ $\sqrt{Hz}$ )	$A_V \times \sqrt{4kT}$ $\times R_{IN}$ (nV/ $\sqrt{Hz}$ )	$\sqrt{4kT \times R_{FB}}$ (nV/ $\sqrt{Hz}$ )	$R_{FB} \times I_N(I_{ERR})$ (nV/ $\sqrt{Hz}$ )	$e_N(FB)$ (nV/ $\sqrt{Hz}$ )	$e_N$ (RTO) OUTPUT REFERRED NOISE (nV/ $\sqrt{Hz}$ )	$e_N$ (RTI) INPUT REFERRED NOISE (nV/ $\sqrt{Hz}$ )
1	30	30	8.6	0.15	22.3	22.3	78	8.6	86	
1	120	120	8.6	0.15	44.6	44.6	300	8.6	307	
100	0.3	30	860	15	223	22.3	78	8.6	892	8.9
100	1.2	120	860	15	446	44.6	300	8.6	1015	10.15

NOTE:

11.  $e_N$  and  $i_N$  values are chosen for illustration purposes and may not reflect actual device performance.

## Revision History

The revision history provided is for informational purposes only and is believed to be accurate, but not warranted. Please go to web to make sure you have the latest Rev.

DATE	REVISION	CHANGE
May 25, 2012	FN6562.0	Initial release.

## Products

Intersil Corporation is a leader in the design and manufacture of high-performance analog semiconductors. The Company's products address some of the industry's fastest growing markets, such as, flat panel displays, cell phones, handheld products, and notebooks. Intersil's product families address power management and analog signal processing functions. Go to [www.intersil.com/products](http://www.intersil.com/products) for a complete list of Intersil product families.

For a complete listing of Applications, Related Documentation and Related Parts, please see the respective device information page on intersil.com: [ISL28617](http://www.intersil.com/ISL28617)

To report errors or suggestions for this datasheet, please go to: [www.intersil.com/askourstaff](http://www.intersil.com/askourstaff)

FTIs are available from our website at: <http://rel.intersil.com/reports/search.php>

For additional products, see [www.intersil.com/product\\_tree](http://www.intersil.com/product_tree)

Intersil products are manufactured, assembled and tested utilizing ISO9000 quality systems as noted in the quality certifications found at [www.intersil.com/design/quality](http://www.intersil.com/design/quality)

Intersil products are sold by description only. Intersil Corporation reserves the right to make changes in circuit design, software and/or specifications at any time without notice. Accordingly, the reader is cautioned to verify that data sheets are current before placing orders. Information furnished by Intersil is believed to be accurate and reliable. However, no responsibility is assumed by Intersil or its subsidiaries for its use; nor for any infringements of patents or other rights of third parties which may result from its use. No license is granted by implication or otherwise under any patent or patent rights of Intersil or its subsidiaries.

For information regarding Intersil Corporation and its products, see [www.intersil.com](http://www.intersil.com)

## Package Outline Drawing

### M24.173

24 LEAD THIN SHRINK SMALL OUTLINE PACKAGE (TSSOP)

Rev 1, 5/10

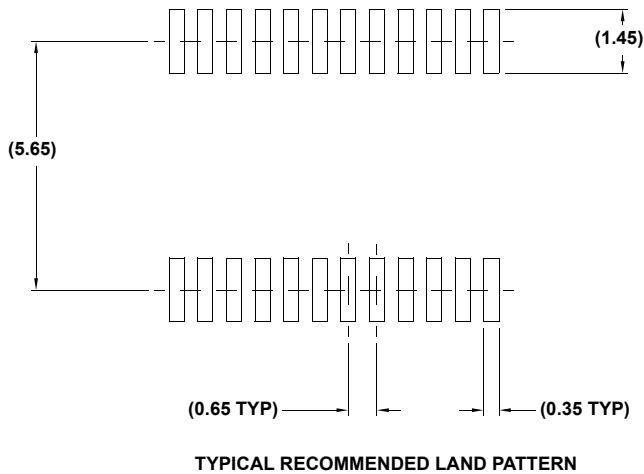
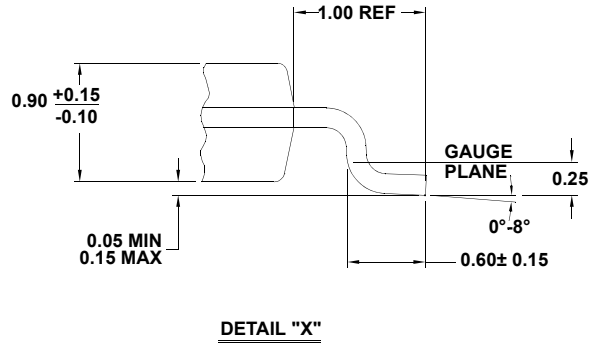
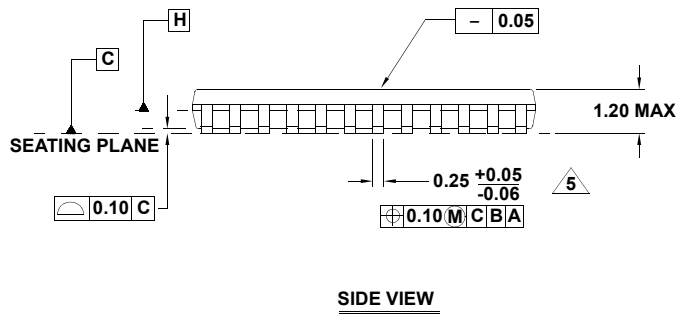
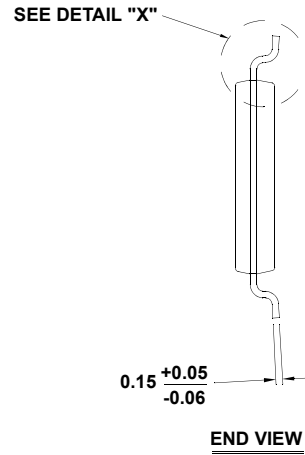
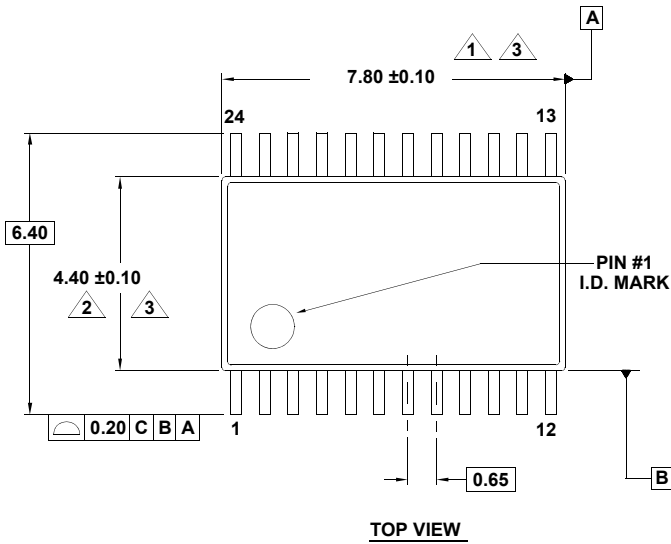

**NOTES:**

1. Dimension does not include mold flash, protrusions or gate burrs. Mold flash, protrusions or gate burrs shall not exceed 0.15 per side.
2. Dimension does not include interlead flash or protrusion. Interlead flash or protrusion shall not exceed 0.25 per side.
3. Dimensions are measured at datum plane H.
4. Dimensioning and tolerancing per ASME Y14.5M-1994.
5. Dimension does not include dambar protrusion. Allowable protrusion shall be 0.08mm total in excess of dimension at maximum material condition. Minimum space between protrusion and adjacent lead is 0.07mm.
6. Dimension in ( ) are for reference only.
7. Conforms to JEDEC MO-153.