

isc Silicon PNP Darlington Power Transistor

2SB1551

**DESCRIPTION**

- Collector-Emitter Breakdown Voltage-  
:  $V_{(BR)CEO} = -80V(\text{Min})$
- High DC Current Gain-  
:  $h_{FE} = 1000(\text{Min}) @ (V_{CE} = -3V; I_C = -5A)$

**APPLICATIONS**

- Designed for power amplifier applications.

**ABSOLUTE MAXIMUM RATINGS( $T_a=25^\circ\text{C}$ )**

SYMBOL	PARAMETER	VALUE	UNIT
$V_{CBO}$	Collector-Base Voltage	-80	V
$V_{CEO}$	Collector-Emitter Voltage	-80	V
$V_{EBO}$	Emitter-Base Voltage	-7	V
$I_C$	Collector Current-Continuous	-10	A
$I_{CM}$	Collector Current-Pulse	-20	A
$P_C$	Collector Power Dissipation @ $T_a=25^\circ\text{C}$	2	W
	Collector Power Dissipation @ $T_c=25^\circ\text{C}$	30	
$T_J$	Junction Temperature	150	$^\circ\text{C}$
$T_{stg}$	Storage Temperature	-55~150	$^\circ\text{C}$

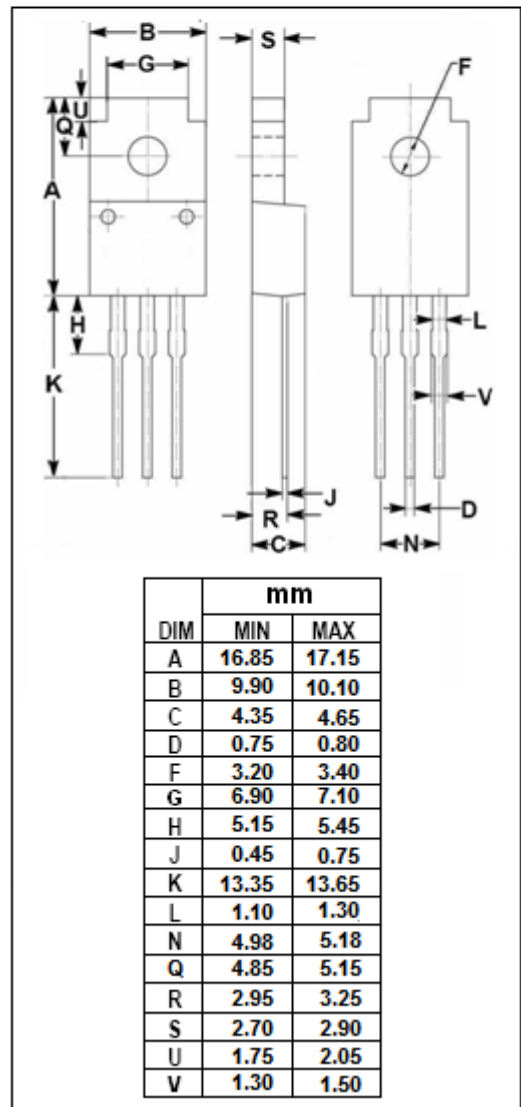
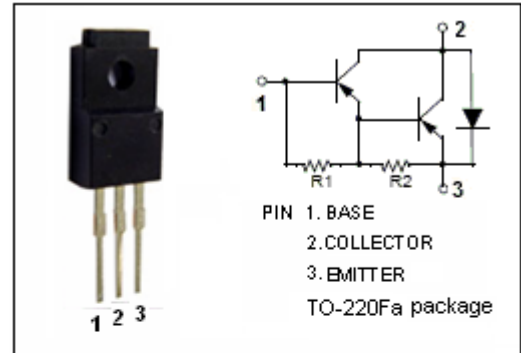

**isc Silicon PNP Darlington Power Transistor****2SB1551****ELECTRICAL CHARACTERISTICS**T<sub>j</sub>=25°C unless otherwise specified

SYMBOL	PARAMETER	CONDITIONS	MIN	TYP.	MAX	UNIT
V <sub>(BR)CEO</sub>	Collector-Emitter Breakdown Voltage	I <sub>C</sub> = -5mA; I <sub>B</sub> = 0	-80			V
V <sub>(BR)CBO</sub>	Collector-Base Breakdown Voltage	I <sub>C</sub> = -50 μ A; I <sub>E</sub> = 0	-80			V
V <sub>CE(sat)</sub>	Collector-Emitter Saturation Voltage	I <sub>C</sub> = -3A; I <sub>B</sub> = -6mA			-1.5	V
I <sub>CBO</sub>	Collector Cutoff Current	V <sub>CB</sub> = -80V; I <sub>E</sub> = 0			-100	μ A
I <sub>EBO</sub>	Emitter Cutoff Current	V <sub>EB</sub> = -5V; I <sub>C</sub> = 0			-3	mA
h <sub>FE</sub>	DC Current Gain	I <sub>C</sub> = -5A; V <sub>CE</sub> = -3V	1000		20000	
C <sub>OB</sub>	Output Capacitance	I <sub>E</sub> = 0; V <sub>CB</sub> = -10V; f <sub>test</sub> = 1MHz		90		pF
f <sub>T</sub>	Current-Gain—Bandwidth Product	I <sub>E</sub> = 0.5A; V <sub>CE</sub> = -5V; f <sub>test</sub> = 10MHz		12		MHz