



# PO49FCT32806A

## 700MHz TTL/CMOS Potato Chip

FEATURES:	DESCRIPTION:
<ul style="list-style-type: none"> <li>. Operating frequency up to 700MHz with 2pf load</li> <li>. Operating frequency up to 500MHz with 5pf load</li> <li>. Operating frequency up to 300MHz with 15pf load</li> <li>. Operating frequency up to 120MHz with 50pf load</li> <li>. Very low output pin to pin skew &lt; 250ps</li> <li>. Very low pulse skew &lt; 200ps</li> <li>. VCC = 1.65V to 3.6V</li> <li>. Propagation delay &lt; 2.9ns max with 15pf load</li> <li>. Low input capacitance: 3pf typical</li> <li>. Dual 1:5 invert fanout</li> <li>. Available in 20pin 300mil wide SOIC package</li> <li>. Available in 20pin 150mil wide QSOP package</li> </ul>	<p>Potato Semiconductor's PO49FCT32806A is designed for world top performance using submicron CMOS technology to achieve 700MHz TTL output frequency with less than 200ps output pulse skew.</p> <p>PO49FCT32806A is a 3.3V CMOS Dual 1 input to 5 outputs Invert Buffered driver to achieve 700MHz output frequency with integrated series damping resistors on all outputs to match 50 ohm transmission line impedance. Typical applications are crystal oscillator, ring oscillator, clock and signal distribution.</p>

### Pin Configuration

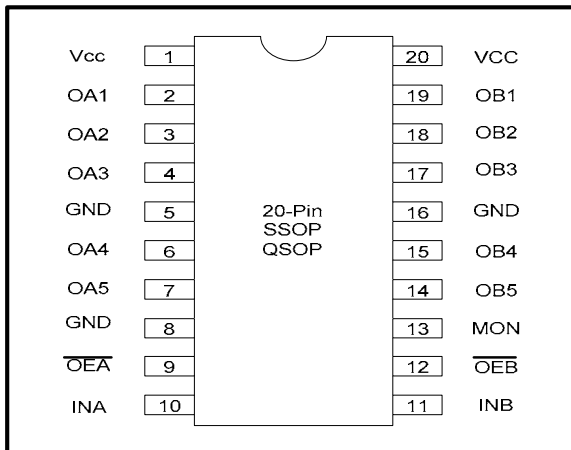

### Logic Block Diagram

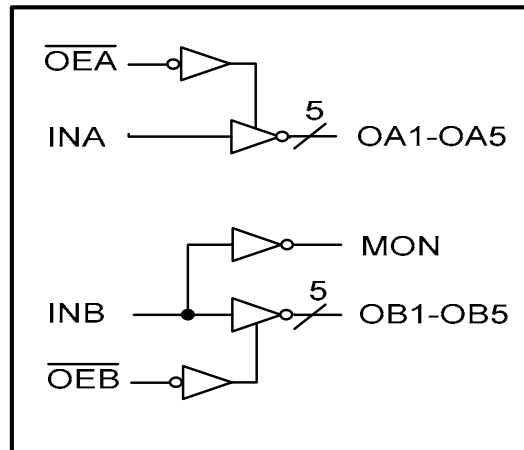

### Pin Description

Pin Name	Description
INA, INB	Signal or clock Inputs
$\overline{OEA}$ , $\overline{OEB}$	Hi-Z State Output Enable Inputs (Active LOW)
OAn, OBn	Signal or clock Outputs
MON	Monitor Output
Vcc, GND	Power, Ground

Inputs		Outputs	
$\overline{OEA}$ , $\overline{OEB}$	INA, INB	OAn, OBn	MON
L	L	H	H
L	H	L	L
H	L	Z	H
H	H	Z	L

**700MHz TTL/CMOS Potato Chip****Maximum Ratings**

Description	Max	Unit
Storage Temperature	-65 to 150	°C
Operation Temperature	-40 to 85	°C
Operation Voltage	-0.5 to +4.6	V
Input Voltage	-0.5 to Vcc+0.5	V
Output Voltage	-0.5 to Vcc+0.5	V

**Note:**

stresses greater than listed under Maximum Ratings may cause permanent damage to the device. This is a stress rating only and functional operation of the device at these or any other conditions above those indicated in the operational sections of this specification is not implied. Exposure to absolute maximum rating conditions for extended periods may affect reliability specification is not implied.

**DC Electrical Characteristics**

Symbol	Description	Test Conditions	Min	Typ	Max	Unit
<b>VOH</b>	Output High voltage	Vcc=3V Vin=VIH or VIL, IOH= -8mA	<b>2.4</b>	<b>3</b>	-	<b>V</b>
<b>VOL</b>	Output Low voltage	Vcc=3V Vin=VIH or VIL, IOH=12mA	-	<b>0.3</b>	<b>0.5</b>	<b>V</b>
<b>VIH</b>	Input High voltage	Guaranteed Logic HIGH Level (Input Pin)	<b>2</b>	-	<b>Vcc</b>	<b>V</b>
<b>VIL</b>	Input Low voltage	Guaranteed Logic LOW Level (Input Pin)	<b>-0.5</b>	-	<b>0.8</b>	<b>V</b>
<b>IOZH</b>	High Impedance Output current	Vcc = 3.6V and Vo = Vcc	-	-	<b>1</b>	<b>uA</b>
<b>IOZL</b>	High Impedance Output current	Vcc = 3.6V and Vo = 0V	-	-	<b>-1</b>	<b>uA</b>
<b>IiH</b>	Input High current	Vcc = 3.6V and Vin = 3.6V	-	-	<b>1</b>	<b>uA</b>
<b>IiL</b>	Input Low current	Vcc = 3.6V and Vin = 0V	-	-	<b>-1</b>	<b>uA</b>
<b>VIK</b>	Clamp diode voltage	Vcc = Min. And IIN = -18mA	-	<b>-0.7</b>	<b>-1.2</b>	<b>V</b>

**Notes:**

1. For conditions shown as Max. or Min., use appropriate value specified under Electrical Characteristics for the applicable device type.
2. Typical values are at Vcc = 3.3V, 25 °C ambient.
3. This parameter is guaranteed but not tested.
4. Not more than one output should be shorted at one time. Duration of the test should not exceed one second.
5. VoH = Vcc - 0.6V at rated current

**700MHz TTL/CMOS Potato Chip****Power Supply Characteristics**

Symbol	Description	Test Conditions (1)	Min	Typ	Max	Unit
<b>IccQ</b>	Quiescent Power Supply Current	Vcc=Max, Vin=Vcc or GND	-	<b>0.1</b>	<b>30</b>	<b>uA</b>

**Notes:**

1. For conditions shown as Max. or Min., use appropriate value specified under Electrical Characteristics for the applicable device type.
2. Typical values are at Vcc = 3.3V, 25°C ambient.
3. This parameter is guaranteed but not tested.
4. Not more than one output should be shorted at one time. Duration of the test should not exceed one second.

**Capacitance**

Parameters (1)	Description	Test Conditions	Typ	Max	Unit
<b>Cin</b>	Input Capacitance	Vin = 0V	<b>3</b>	<b>4</b>	<b>pF</b>
<b>Cout</b>	Output Capacitance	Vout = 0V	-	<b>6</b>	<b>pF</b>

**Notes:**

- 1 This parameter is determined by device characterization but not production tested.

**Switching Characteristics**

Symbol	Description	Test Conditions (1)	Max	Unit
<b>tPLH &amp; tPHL</b>	Propagation Delay INA to OAn, INB to OBn	CL = 15pF	<b>2.9</b>	<b>ns</b>
<b>tpZH or tpZL</b>	Output Enable Time	CL = 15pF	<b>2.5</b>	<b>ns</b>
<b>tpHZ or tPLZ</b>	Output Disable Time	CL = 15pF	<b>2.5</b>	<b>ns</b>
<b>tr/tf</b>	Rise/Fall Time	0.8V – 2.0V	<b>1</b>	<b>ns</b>
<b>tsk(p)</b>	Pulse Skew (Same Package)	CL = 15pF, 125MHz	<b>0.2</b>	<b>ns</b>
<b>tsk(o)</b>	Output Pin to Pin Skew (Same Package)	CL = 15pF, 125MHz	<b>0.25</b>	<b>ns</b>
<b>tsk(pp)</b>	Output Skew (Different Package)	CL = 15pF, 125MHz	<b>0.4</b>	<b>ns</b>
<b>fmax</b>	Input Frequency	CL = 50pF	<b>120</b>	<b>MHz</b>
<b>fmax</b>	Input Frequency	CL = 15pF	<b>300</b>	<b>MHz</b>
<b>fmax</b>	Input Frequency	CL = 5pF	<b>500</b>	<b>MHz</b>
<b>fmax</b>	Input Frequency	CL = 2pF	<b>700</b>	<b>MHz</b>

**Notes:**

1. See test circuits and waveforms.
2. tPLH, tPHL, tsk(p), and tsk(o) are production tested. All other parameters guaranteed but not production tested.
3. Airflow of 1m/s is recommended for frequencies above 133MHz



## 700MHz TTL/CMOS Potato Chip

### Test Waveforms

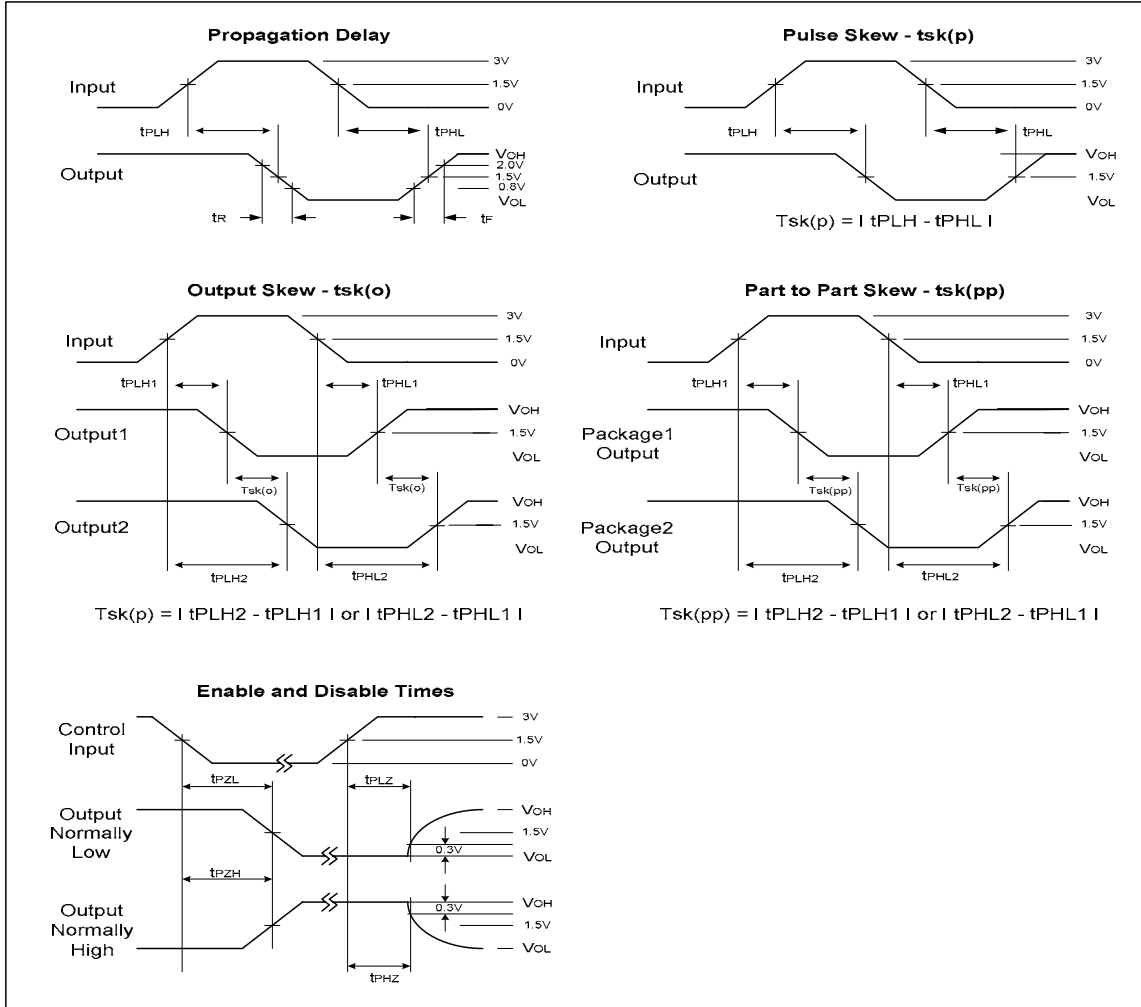

### Test Circuit

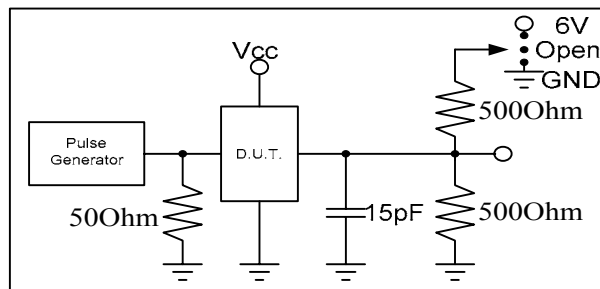
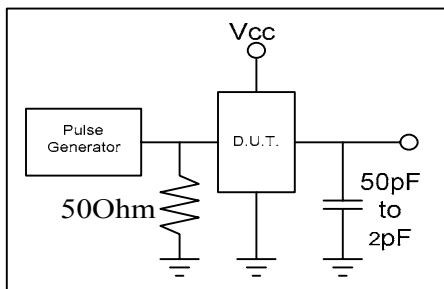



## 700MHz TTL/CMOS Potato Chip

### Packaging Mechanical Drawing: 20 pin QSOP

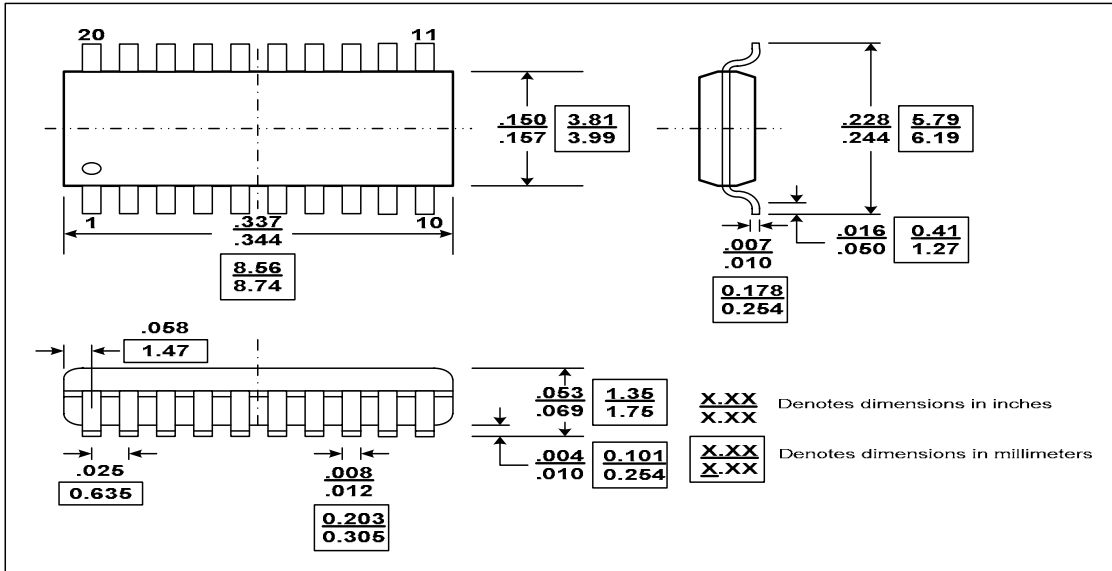

### Packaging Mechanical Drawing: 20 pin SOIC

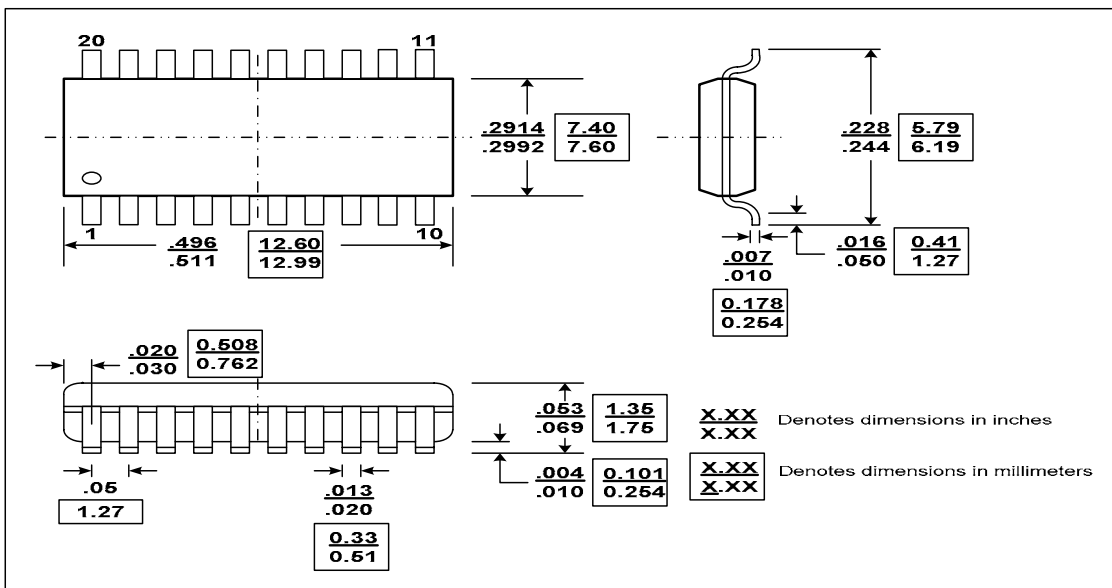



## 700MHz TTL/CMOS Potato Chip

### Packaging Mechanical Drawing: 20 pin SSOP

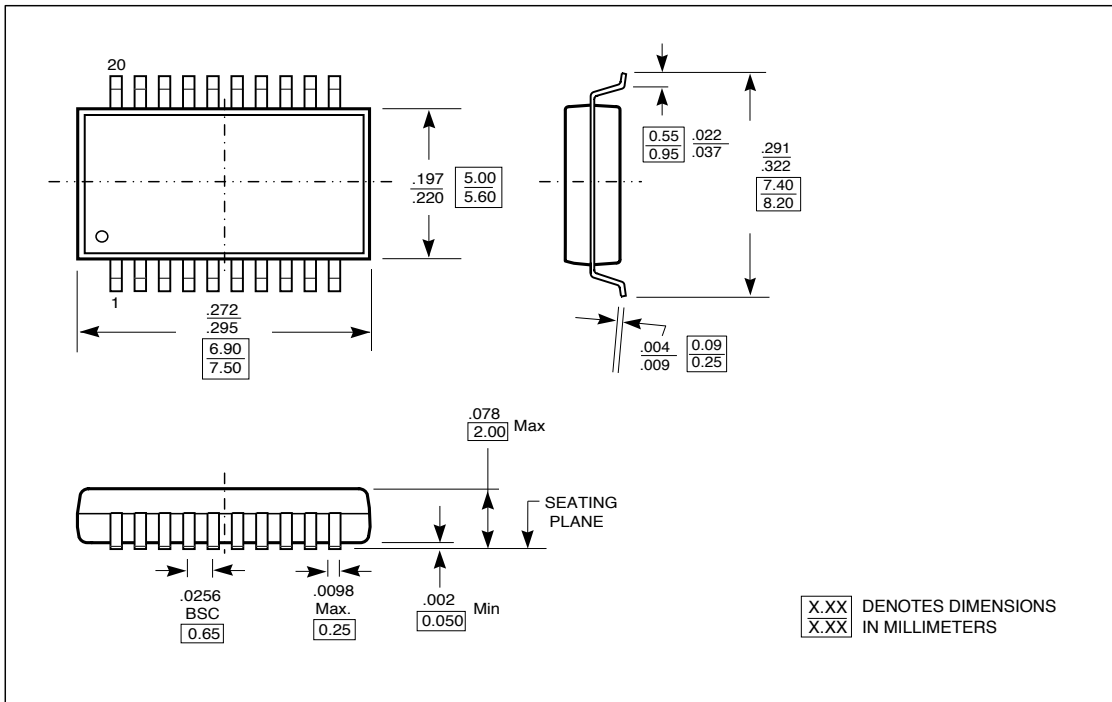

### IC Ordering Information

Ordering Code	Package	Top-Marking	T <sub>A</sub>
PO49FCT32806ACU for Tube	20pin 300mil SOIC	Pb-free & Green	PO49FCT32806AC -40°C to 85°C
PO49FCT32806ACR for Tape & Reel	20pin 300mil SOIC	Pb-free & Green	PO49FCT32806AC -40°C to 85°C
PO49FCT32806AQU for Tube	20pin 150mil QSOP	Pb-free & Green	PO49FCT32806AQ -40°C to 85°C
PO49FCT32806AQR for Tape & Reel	20pin 150mil QSOP	Pb-free & Green	PO49FCT32806AQ -40°C to 85°C
PO49FCT32806ASSU for Tube	20pin 209mil SSOP	Pb-free & Green	PO49FCT32806ASS -40°C to 85°C
PO49FCT32806ASSR for Tape & Reel	20pin 209mil SSOP	Pb-free & Green	PO49FCT32806ASS -40°C to 85°C

### IC Package Information

PACKAGE CODE	PACKAGE TYPE	TAPE WIDTH (mm)	TAPE PITCH (mm)	TAPE & REEL PIN 1 LOCATION	TAPE TRAILER LENGTH	QTY PER TAPE	TAPE LEADER LENGTH	QTY PER TUBE
C	20pin 300mil SOIC	24	12	Top Left Corner	26 (12")	1000	43 (20")	38
Q	20pin 150mil QSOP	16	8	Top Left Corner	39 (12")	3000	64 (20")	55
SS	20pin 209mil SSOP	16	12	Top Left Corner	26 (12")	2000	43 (20")	66