

Solid State Control Solutions for Three Phase 1 HP Motor



ON Semiconductor
Formerly a Division of Motorola
<http://onsemi.com>

Prepared by: Alfredo Ochoa, Alex Lara & Gabriel Gonzalez
Thyristors Applications Engineers

APPLICATION NOTE

INTRODUCTION

In all kinds of manufacturing, it is very common to have equipment that has three phase motors for doing different work functions on the production lines. These motor functions can be extruders, fans, transport belts, mixers, pumps, air compressors, etc. Therefore, it is necessary to have equipment for controlling the start and stop of the motors and in some cases for reversing them. Actually, one of the most common solutions for performing this control functions is by using three phase magnetic starters. It consists of a block with three main mechanical contacts which provide the power to the three main terminals of the motor once its coil is energized. However, the magnetic starter has a lot of disadvantages and the most common appear when they are driving high current levels that can cause arcing and sparks on their contacts each time they are activated or de-activated. Because of these kind of effects the contacts of the magnetic starters get very significantly damaged causing problems in their functionality. With time it can cause bad and inefficient operation of the motors. This is why, thyristor should be considered as a low cost alternative and indeed a powerful device for motor control applications. Thyristors can take many forms but they have certain features in common. All of them are solid state switches that act as open circuits capable of withstanding the rated voltage until triggered. When they are triggered, thyristors become low impedance current paths and remain in that condition (i.e. conduction) until the current either stops or drops below a minimum value called the holding level. Once a thyristor has been triggered, the trigger current can be removed without turning off the device.

DEFINITIONS

Three phase induction motor.

A three phase induction motor consists of a stator winding and a rotor of one of the two following types: one type is a squirrel-cage rotor with a winding consisting of conducting bars embedded in slots in the rotor iron and short circuited at each end by conducting end rings. The other type is a wound rotor with a winding similar to and having the same number of poles as the stator winding, with the terminals of the winding being connected to the slip rings or collector rings on the left end of the shaft. Carbon brushes bearing on these rings make the rotor terminals available at points external to the motor so that additional resistance can be inserted in the rotor circuit if desired.

Three phase voltages of stator frequency are induced in the rotor, and the accompanying currents are determined by the voltage magnitude and rotor impedance. Because they are induced by the rotating stator field, these rotor currents inherently produce a rotor field with the same number of poles as the stator and rotating at the same speed with respect to the stationary rotor. Rotor and stator fields are thus stationary with respect to each other in space, and a starting torque is produced. If this torque is sufficient to overcome the opposition to rotation created by the shaft load the motor will come up to its operating speed. The operating speed can never equal the synchronous speed of the stator field.

The following figure shows a three phase 1HP motor controlled through a conventional magnetic starter which has an over-load relay for protecting the motor against over-load phenomena.

AND8008/D

Power Schematic

220 V_{rms} 60 Hz

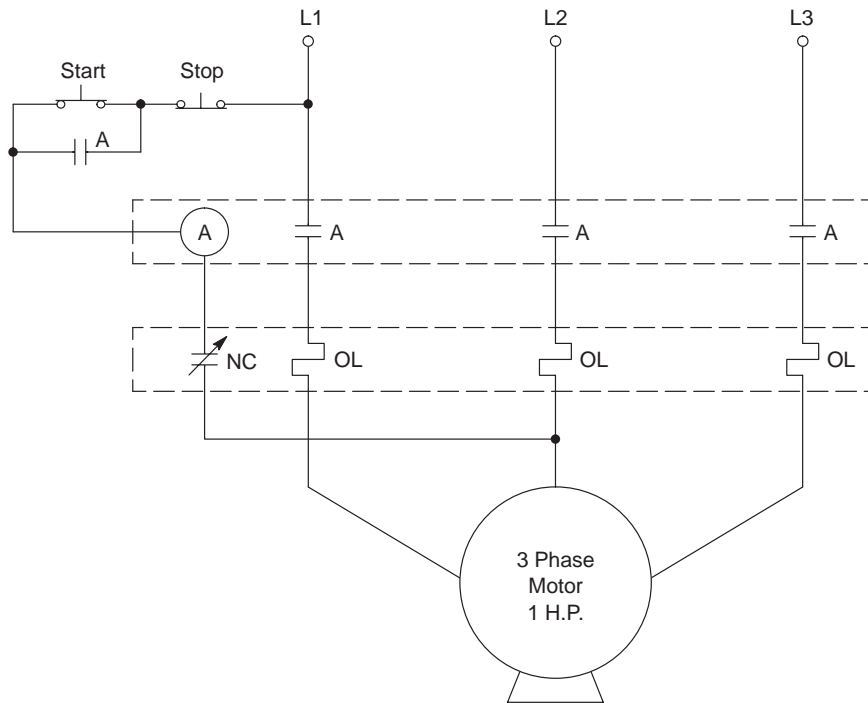

When the start button is pushed on, the coil of the magnetic starter (A) is energized, thereby, the mechanical switch contacts close allowing current-flow through the motor which starts it to operate. If the stop button is pushed, the coil (A) will be de-energized causing the motor to stop because of the mechanical switch contacts opened. In addition, if an overload phenomena exists in the circuit of the motor, the switch contact (NC) of the overload relay will open de-energizing the coil and protecting the motor against any kind of damage.

Magnetic starters have a lot of disadvantages like arcing, corrosion of the switch contacts, sparks, noisy operation, short life span, etc. Therefore, in some motor applications, it is not useful to control the motors by using magnetic starters since the results can be undesirable.

On the other hand, the following schematic diagrams show how thyristors can perform the same control function for starting and stopping a three phase 1HP motor. In addition, the diagrams below show an over load circuit for protecting the motor against overload phenomena.

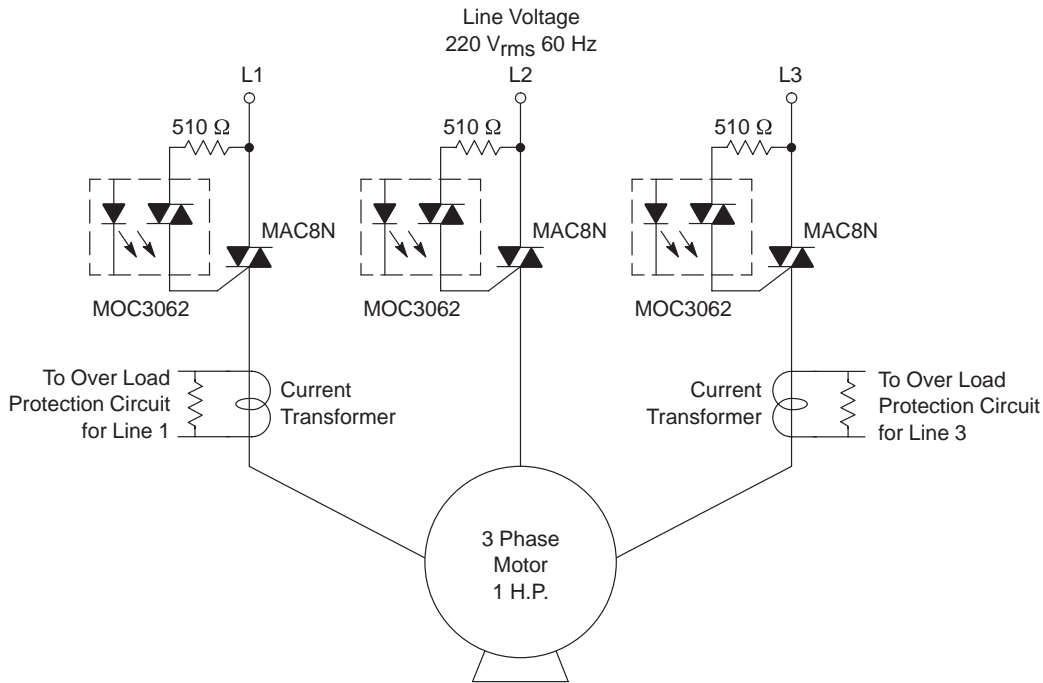

Diagram 1 shows how three triacs (MAC8M) substitute the mechanical contacts of the conventional magnetic starter (shown previously) for supplying the power to the three phase 1HP motor once the triacs are triggered.

It is important to mention that the optocoupler devices (MOC3061) will supply the signal currents to the triacs and hence the motor keeping the same phase shifting (120 electrical degrees) between lines. This is because these optocouplers (MOC3061) have zero crossing circuits within them.

Another important thing must be considered as a protection for the triacs (MAC8M) against fast voltage transients, is a RC network called snubber which consists of a series resistor and capacitor placed around the triacs. These components along with the load inductance from a series CRL circuit.

Many RC combinations are capable of providing acceptable performance. However, improperly used snubbers can cause unreliable circuit operation and damage

to the semiconductor device. Snubber design involves compromises. They include cost, voltage rate, peak voltage, and turn-on stress. Practical solutions depend on the device and circuit physics.

Diagram 2 shows an electronic over-load circuit which provides very reliable protection to the motor against over load conditions. The control signals for the two electronic over-load circuits are received from the shunt resistors connected in parallel to the two current transformers placed in two of the three main lines (L1, L3) for sensing the current flowing through the motor when it is operating. The level of the voltage signals appearing in the shunt resistors is dependent on the current flowing through each main line of the motor. Therefore, if it occurs, that an over load condition in the power circuit of the motor, that voltage level will increase its value causing the activation of the electronic over-load circuits which will stop the motor by protecting it against the over-load condition experienced.

Over Load Protection Circuit for Line 1

Diagram 2

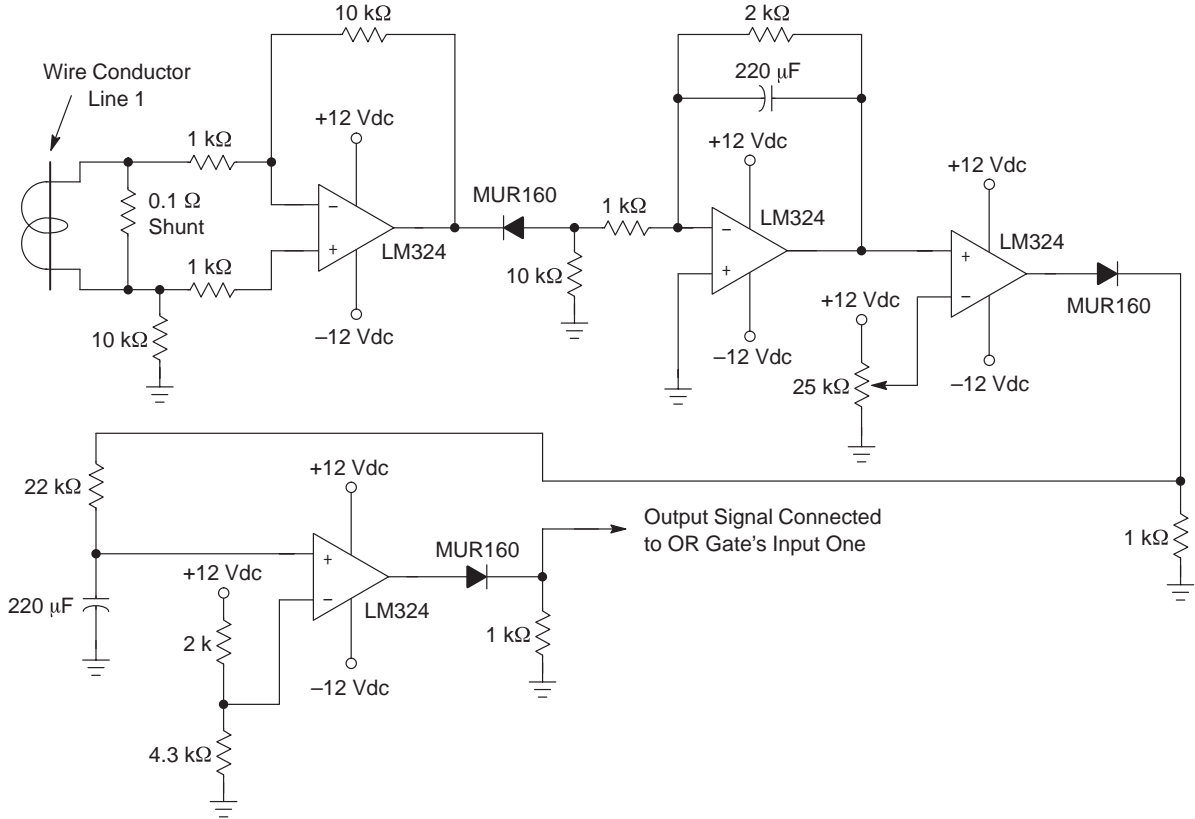

Over Load Protection Circuit for Line 3

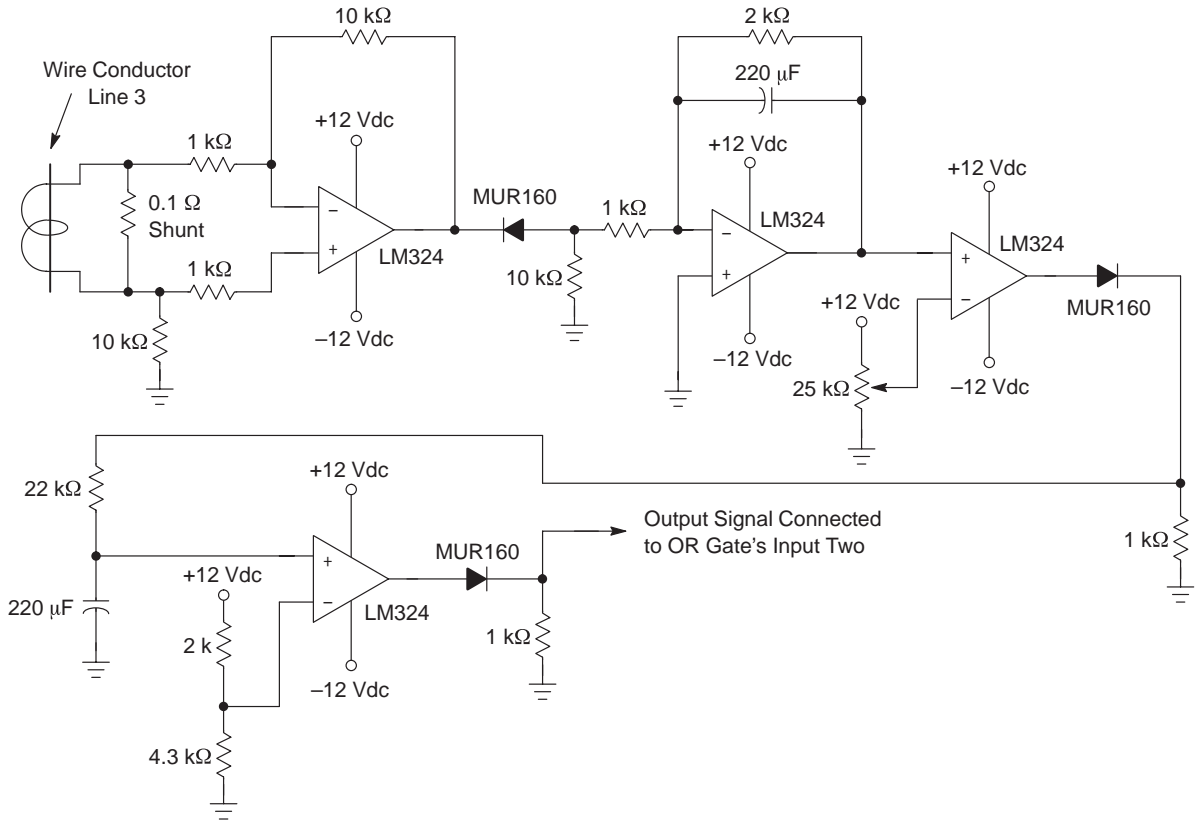

Start/Stop Control Circuit

Diagram 3

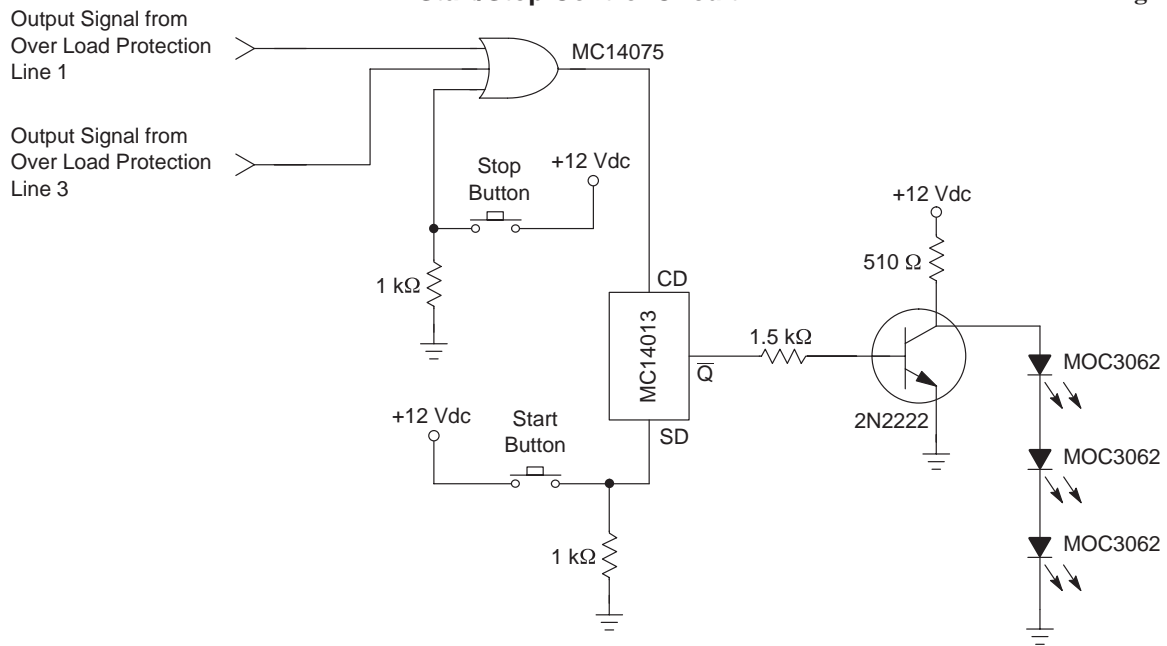
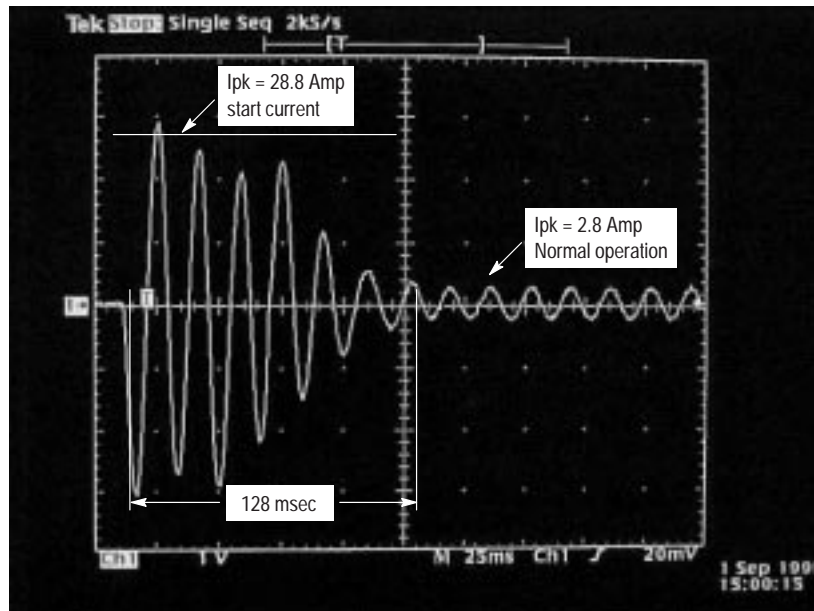

Diagram 3 shows the main electronic control circuit for controlling the start and stop of the motor each time it is needed. If the start button is pushed on, the Flip Flop (MC14013) is activated triggering the transistor (2N2222) which turns on the optocoupler's LED's which in turn the three triacs (MAC8M) get triggered and finally starts the motor. The motor will stop to operate, whenever the stop

button is pushed or any overload condition occurs in the power circuit of the motor.

The following plot shows the motor's start current waveform on one of the three phases when the motor starts to operate under normal operation conditions and without driving any kind of mechanical load:



This other plot shows the motor's start current waveform of the three phases when the motor starts to operate under normal operation conditions and without mechanical load.

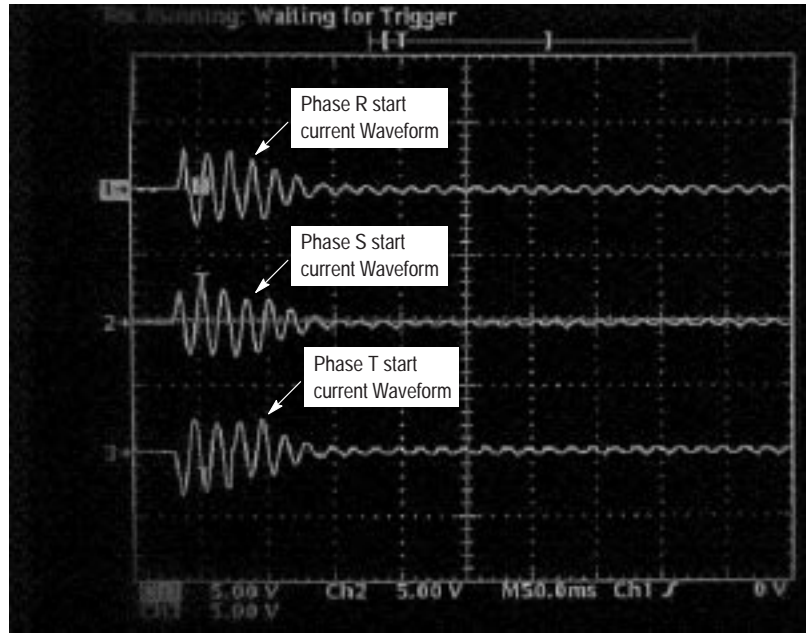

The previous plots show the maximum start current IPK of the motor when it starts to operate and how long it takes before the current reaches its nominal value. Here, It is important to mention that the triacs (MAC8N) were selected by taking into consideration the motor's start current value as well as the ITSM capability of these devices. Therefore, if it is needed to control motors with higher power (more than 1HP), first, it would be necessary to characterize them in order to know their current characteristics. Next be able to select the right triacs for controlling the motor without any kind of problems.

Another important item must be considered if it is needed to control motors with higher power. These are the

electronic over-load circuits, which have to be adjusted taking into consideration the level of overload current that is needed to protect, and is dependent on the kind of motor that is being controlled.

Based in the previous diagrams and plots, it has been proven that triacs can substitute the function of the magnetic starters for starting and stopping a three phase 1HP motor as well as for protecting it against overload conditions.

The following schematics show a solid state solution for controlling and reversing a three phase 1HP motor:

Reverse Control Schematic

Schematic 1

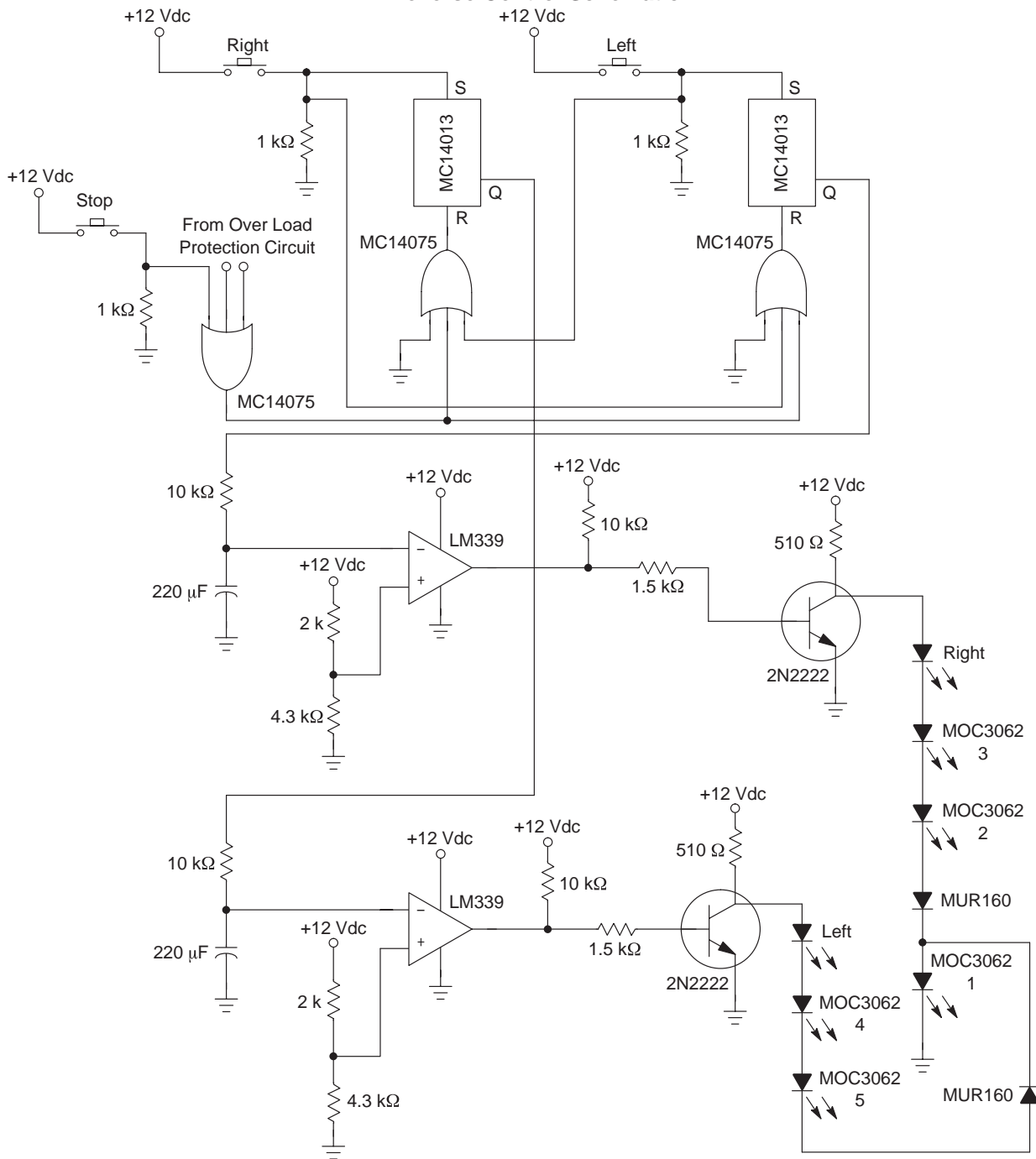

Schematic 1 shows the control diagram for controlling and reversing the motor depending on which direction it is needed to operate. If the right-button is pushed-on, the triacs number 1, 2, and 3 (shown in the schematic 2) will be activated, thereby, the motor will operate in the right direction. If the left button is pushed-on, the triacs numbered 1, 4, and 5 will be activated causing the left operation of the motor. Because of the design of the control circuit, it is possible to reverse the motor without stopping it once it is operating in right direction. This means, it is not necessary to stop the motor in order to reverse itself.

Nevertheless, it is important to mention that the control circuit takes a delay-time (of around 3 seconds) before it activates the other triacs (1,4,5) for reversing the motor. This delay is to assure that the triacs operating (1,2,3) will be completely in the off state before it turns-on those other triacs. This delay-time is very important because if the triacs for reversing the motor are activated before the other triacs triggered have reached their completely turned-off state, it may cause a big short circuit between phases. If this happens the triacs will be damaged.

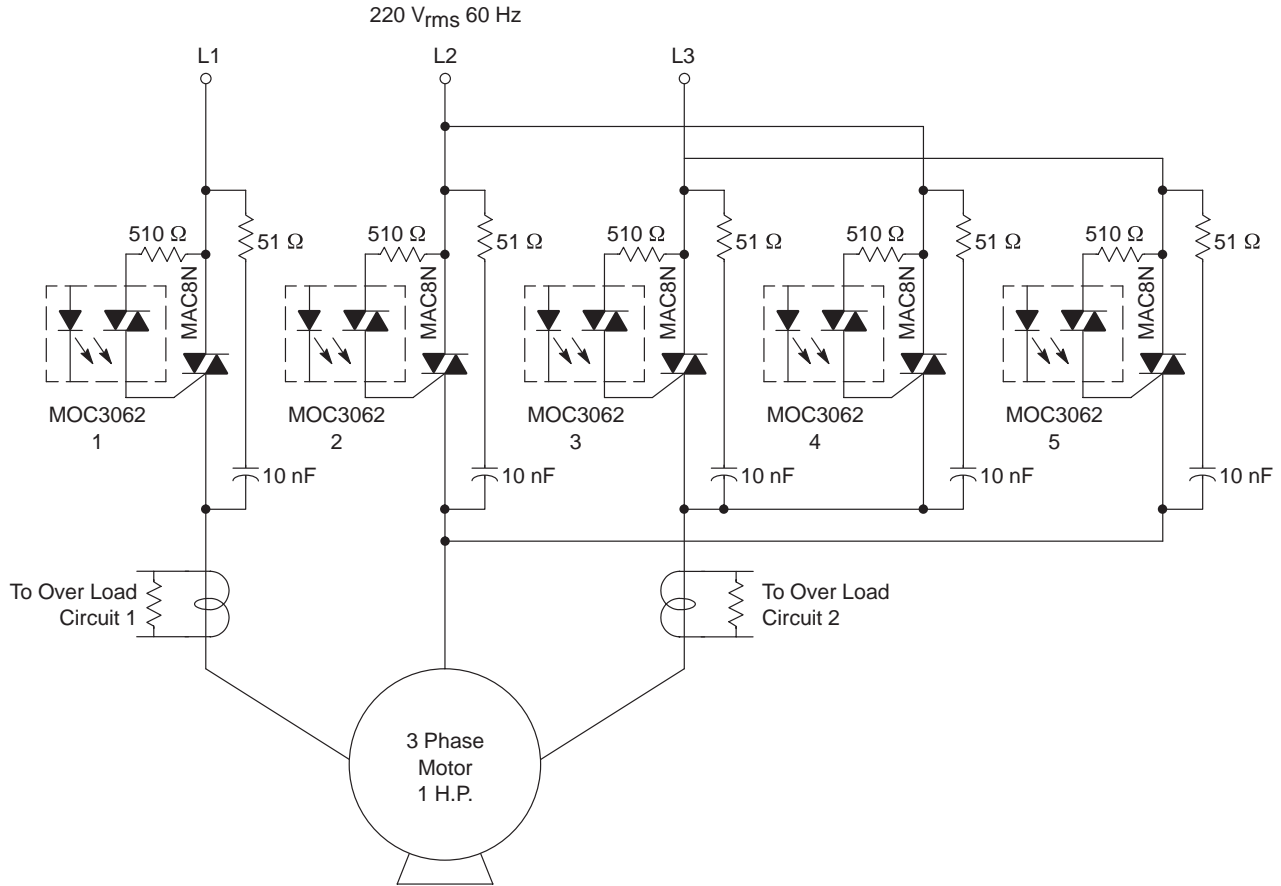

Schematic 2 shows the power diagram for reversing a three phase 1HP motor. The way it makes this reverse function control is by changing the phases—order supplied to the motor through the triacs (number 4 and 5) and it is based in the motor's principle for reversing itself. This diagram also shows two current transformer placed in two of the three main lines of the motor for sending the control signals to the electronic overload circuit described previously. So this means, that the same overload concept is applicable to these schematics as well as the motor's start current waveforms and characteristics shown and explained previously.

In conclusion, it is proven that thyristors can substitute to the magnetic starters for making three phase motor control function in more efficient ways. Because thyristors are very reliable power switches, they can offer many advantages in motor applications. Some of the advantages of triacs as replacements for relays include:

- High Commutating di/dt and High Immunity to dv/dt @ 125°C
- Small size and light weight.

- Safety – freedom from arcing and spark initiated explosions.
- Long life span – contact bounce and burning eliminated.
- Fast operation – turn-on in microseconds and turn-off in milliseconds.
- Quiet operation.

The above mentioned points are only some of the big advantages that can be had if thyristors are used for making motor control function. Besides, the total cost of the previous control and power circuits does not exceed to the cost of the conventional magnetic starters.

One more consideration is that extreme environmental temperatures could effect the functionality of the electronic control circuits described herein. Therefore, if the operation is needed under extreme ambient temperatures, the designer must evaluate the parameter variation of all the electronic devices in order to assure the right operation in the application circuit.

Notes

Notes

Notes

ON Semiconductor and  are trademarks of Semiconductor Components Industries, LLC (SCILLC). SCILLC reserves the right to make changes without further notice to any products herein. SCILLC makes no warranty, representation or guarantee regarding the suitability of its products for any particular purpose, nor does SCILLC assume any liability arising out of the application or use of any product or circuit, and specifically disclaims any and all liability, including without limitation special, consequential or incidental damages. "Typical" parameters which may be provided in SCILLC data sheets and/or specifications can and do vary in different applications and actual performance may vary over time. All operating parameters, including "Typicals" must be validated for each customer application by customer's technical experts. SCILLC does not convey any license under its patent rights nor the rights of others. SCILLC products are not designed, intended, or authorized for use as components in systems intended for surgical implant into the body, or other applications intended to support or sustain life, or for any other application in which the failure of the SCILLC product could create a situation where personal injury or death may occur. Should Buyer purchase or use SCILLC products for any such unintended or unauthorized application, Buyer shall indemnify and hold SCILLC and its officers, employees, subsidiaries, affiliates, and distributors harmless against all claims, costs, damages, and expenses, and reasonable attorney fees arising out of, directly or indirectly, any claim of personal injury or death associated with such unintended or unauthorized use, even if such claim alleges that SCILLC was negligent regarding the design or manufacture of the part. SCILLC is an Equal Opportunity/Affirmative Action Employer.

PUBLICATION ORDERING INFORMATION

USA/EUROPE Literature Fulfillment:

Literature Distribution Center for ON Semiconductor
 P.O. Box 5163, Denver, Colorado 80217 USA
Phone: 303-675-2175 or 800-344-3860 Toll Free USA/Canada
Fax: 303-675-2176 or 800-344-3867 Toll Free USA/Canada
Email: ONlit@hibbertco.com

Fax Response Line*: 303-675-2167
 800-344-3810 Toll Free USA/Canada
 *To receive a Fax of our publications

N. America Technical Support: 800-282-9855 Toll Free USA/Canada

ASIA/PACIFIC: LDC for ON Semiconductor – Asia Support

Phone: 303-675-2121 (Tue-Fri 9:00am to 1:00pm, Hong Kong Time)
Email: ONlit-asia@hibbertco.com

JAPAN: ON Semiconductor, Japan Customer Focus Center
 4-32-1 Nishi-Gotanda, Shinagawa-ku, Tokyo, Japan 141-8549

Phone: 81-3-5487-8345
Email: r14153@onsemi.com

ON Semiconductor Website: <http://onsemi.com>

For additional information, please contact your local Sales Representative.