

8 PIN SOP HIGH SPEED 1Mbit/s TRANSISTOR PHOTOCOUPLER

EL045X EL050X series

Features

- High speed 1Mbit/s
- High isolation voltage between input and output (Viso=3750 Vrms)
- Guaranteed performance from 0°C to 70 °C
- Wide operating temperature range of -55°C to 100 °C
- Pb free and RoHS and Halogen free compliant
- cUL approved (No. E214129)
- VDE approved (No. 40028116)
- SEMKO approved
- NEMKO approved
- DEMKO approved
- FIMKO approved

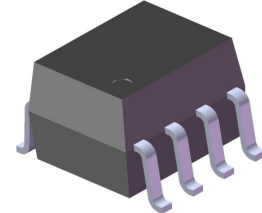

Description

The EL050x and EL045x devices each consist of an infrared emitting diode, optically coupled to a high speed photo detector transistor. A separate connection for the photodiode bias and output-transistor collector increase the speed by several orders of magnitude over conventional phototransistor couplers by reducing the base-collector capacitance of the input transistor.

The devices are packaged in an 8-pin small outline package which conforms to the standard SO-8 footprint.

Applications

- Line receivers
- Telecommunication equipments
- Power transistor isolation in motor drives
- Replacement for low speed phototransistor photo couplers
- Feedback loop in switch-mode power supplies
- Home appliances
- High speed logic ground isolation

Schematic

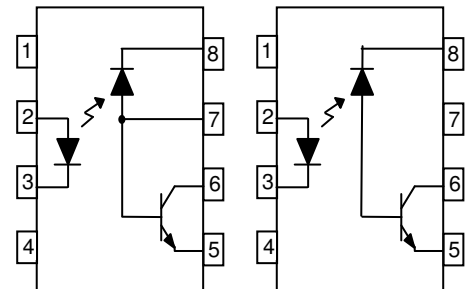

EL0500 / EL0501

Pin Configuration

1. No Connection
2. Anode
3. Cathode
4. No Connection
5. Gnd
6. Vout
7. V_B
8. V_{CC}

EL0452

Pin Configuration

1. No Connection
2. Anode
3. Cathode
4. No Connection
5. Gnd
6. Vout
7. No Connection
8. V_{CC}



LIGHTING FOREVER

8 PIN SOP HIGH SPEED 1Mbit/s TRANSISTOR PHOTOCOUPLER

EL045X EL050X series

Absolute Maximum Ratings ($T_a=25^\circ\text{C}$)

Parameter		Symbol	Rating	Unit
Input	Forward current	I_F	25	mA
	Peak forward current (50% duty, 1ms P.W)	I_{FP}	50	mA
	Peak transient current ($\leq 1\mu\text{s}$ P.W, 300pps)	I_{Ftrans}	1	A
	Reverse voltage	V_R	5	V
	Power dissipation	P_{IN}	45	mW
Output	Power dissipation	P_O	100	mW
	Emitter-Base reverse voltage	EL0500 EL0501 V_{EBR}	5	V
	Base current	EL0500 EL0501 I_B	5	mA
	Average Output current	$I_{O(AVG)}$	8	mA
	Peak Output current	$I_{O(PK)}$	16	mA
	Output voltage	V_O	-0.5 to 20	V
	Supply voltage	V_{CC}	-0.5 to 30	V
Isolation voltage ^{*1}		V_{ISO}	3750	V rms
Operating temperature		T_{OPR}	-55 ~ +100	$^\circ\text{C}$
Storage temperature		T_{STG}	-55 ~ +125	$^\circ\text{C}$
Soldering temperature ^{*2}		T_{SOL}	260	$^\circ\text{C}$

Notes

*1 AC for 1 minute, R.H.= 40 ~ 60% R.H. In this test, pins 1, 2, 3, 4 are shorted together, and pins 5, 6, 7, 8 are shorted together.

*2 For 10 seconds.



LIGHTING FOREVER

8 PIN SOP HIGH SPEED 1Mbit/s TRANSISTOR PHOTOCOUPLER

EL045X EL050X seriesElectrical Characteristics ($T_A=0$ to 70°C unless specified otherwise)**Input**

Parameter	Symbol	Min.	Typ.*	Max.	Unit	Conditions
Forward voltage	V_F	-	1.5	1.8	V	$I_F = 16\text{mA}$
Reverse Voltage	V_R	5.0	-	-	V	$I_R = 10\mu\text{A}$
Temperature coefficient of forward voltage	$\Delta V_F/\Delta T_A$	-	-1.6	-	mV/ $^\circ\text{C}$	$I_F = 16\text{mA}$

Output

Parameter	Symbol	Min.	Typ.*	Max.	Unit	Conditions
Logic High Output Current	I_{OH}	-	0.001	0.5	μA	$I_F=0\text{mA}$, $V_O=V_{CC}=5.5\text{V}$, $T_A=25^\circ\text{C}$
		-	0.01	1		$I_F=0\text{mA}$, $V_O=V_{CC}=15\text{V}$, $T_A=25^\circ\text{C}$
		-	-	50		$I_F=0\text{mA}$, $V_O=V_{CC}=15\text{V}$
Logic Low Supply Current	I_{CCL}	-	140	200	μA	$I_F=16\text{mA}$, $V_O=\text{Open}$, $V_{CC}=15\text{V}$
Logic High Supply Current	I_{CCH}	-	0.01	1	μA	$I_F=0\text{mA}$, $V_O=\text{Open}$, $V_{CC}=15\text{V}$, $T_A=25^\circ\text{C}$
		-	-	2		$I_F=0\text{mA}$, $V_O=\text{Open}$, $V_{CC}=15\text{V}$



LIGHTING FOREVER

8 PIN SOP HIGH SPEED 1Mbit/s TRANSISTOR PHOTOCOUPLER

EL045X EL050X series

Transfer Characteristics ($T_A=0$ to 70°C unless specified otherwise)

Parameter		Symbol	Min.	Typ.*	Max.	Unit	Conditions
Current Transfer Ratio	EL0500	CTR	7	-	50	%	$I_F = 16\text{mA}$, $V_O = 0.4\text{V}$, $V_{CC}=4.5\text{V}$, $T_A=25^\circ\text{C}$
	EL0501 EL0452		19	-	50		
	EL0500		5	-	-		$I_F = 16\text{mA}$, $V_O = 0.5\text{V}$, $V_{CC}=4.5\text{V}$
	EL0501 EL0452		15	-	-		
Logic Low Output Voltage	EL0500	V_{OL}	-	0.18	0.4	V	$I_F = 16\text{mA}$, $I_O = 1.1\text{mA}$, $V_{CC}=4.5\text{V}$, $T_A=25^\circ\text{C}$
	EL0501 EL0452		-	0.18	0.4		$I_F = 16\text{mA}$, $I_O = 3\text{mA}$, $V_{CC}=4.5\text{V}$, $T_A=25^\circ\text{C}$
	EL0500		-	-	0.5		$I_F = 16\text{mA}$, $I_O = 0.8\text{mA}$, $V_{CC}=4.5\text{V}$
	EL0501 EL0452		-	-	0.5		$I_F=16\text{mA}$, $I_O=2.4\text{mA}$, $V_{CC}=4.5\text{V}$



LIGHTING FOREVER

8 PIN SOP HIGH SPEED 1Mbit/s TRANSISTOR PHOTOCOUPLER

EL045X EL050X series**Switching Characteristics ($T_A=0$ to 70°C unless specified otherwise, $I_F=16\text{mA}$, $V_{CC}=5\text{V}$)**

Parameter	Symbol	Min.	Typ.*	Max.	Unit	Conditions	
Propagation Delay Time to Logic Low	EL0500	TPHL	-	-	1.5	μs	$R_L=4.1\text{K}\Omega$, $T_A=25^\circ\text{C}$
			-	-	2.0		$R_L=4.1\text{K}\Omega$
	EL0501 EL0452		-	-	0.8		$R_L=1.9\text{K}\Omega$, $T_A=25^\circ\text{C}$
			-	-	1.0		$R_L=1.9\text{K}\Omega$
Propagation Delay Time to Logic High	EL0500	TPLH	-	-	1.5	μs	$R_L=4.1\text{K}\Omega$, $T_A=25^\circ\text{C}$
			-	-	2.0		$R_L=4.1\text{K}\Omega$
	EL0501 EL0452		-	-	0.8		$R_L=1.9\text{K}\Omega$, $T_A=25^\circ\text{C}$
			-	-	1.0		$R_L=1.9\text{K}\Omega$
Common Mode Transient Immunity at Logic High	EL0500	CM _H	-	1,000	-	$V/\mu\text{s}$	$I_F = 0\text{mA}$, $V_{CM}=10\text{Vp-p}$, $R_L=4.1\text{K}\Omega$, $T_A = 25^\circ\text{C}$
	EL0452 EL0501		-	1,000	-		$I_F = 0\text{mA}$, $V_{CM}=10\text{Vp-p}$, $R_L=1.9\text{K}\Omega$, $T_A = 25^\circ\text{C}$
Common Mode Transient Immunity at Logic Low (Fig.9) ^{*3}	EL0500	CM _L	-	1,000	-	$V/\mu\text{s}$	$I_F = 16\text{mA}$, $V_{CM}=10\text{Vp-p}$, $R_L=4.1\text{K}\Omega$, $T_A = 25^\circ\text{C}$
	EL0452 EL0501		-	1,000	-		$I_F = 16\text{mA}$, $V_{CM}=10\text{Vp-p}$, $R_L=1.9\text{K}\Omega$, $T_A = 25^\circ\text{C}$

8 PIN SOP HIGH SPEED 1Mbit/s TRANSISTOR PHOTOCOUPLER

EL045X EL050X series

Typical Performance Curves

Figure 1. Forward Current vs Forward Voltage

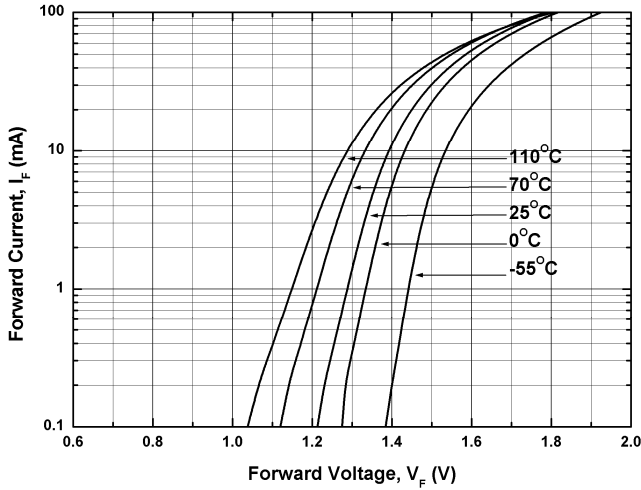

Figure 2. Current Transfer Ratio vs Forward Current

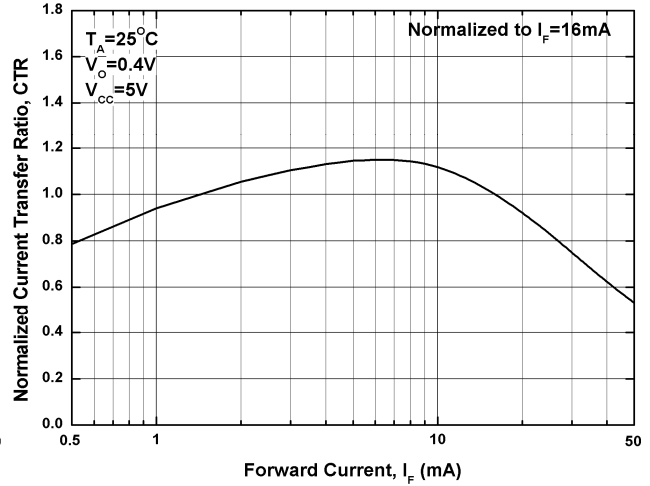

Figure 3. Current Transfer Ratio vs Ambient Temperature

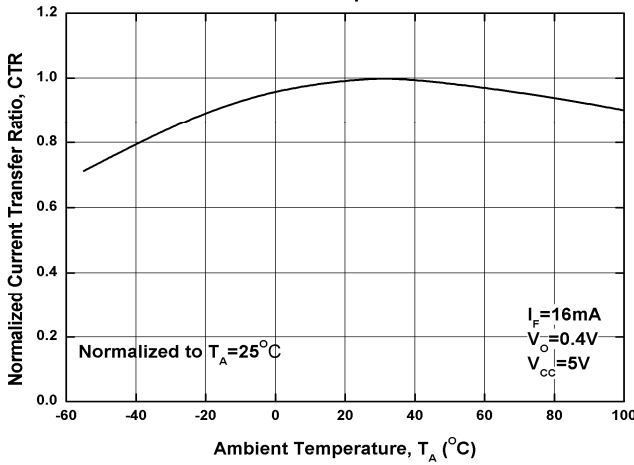

Figure 4. Output Current vs Output Voltage

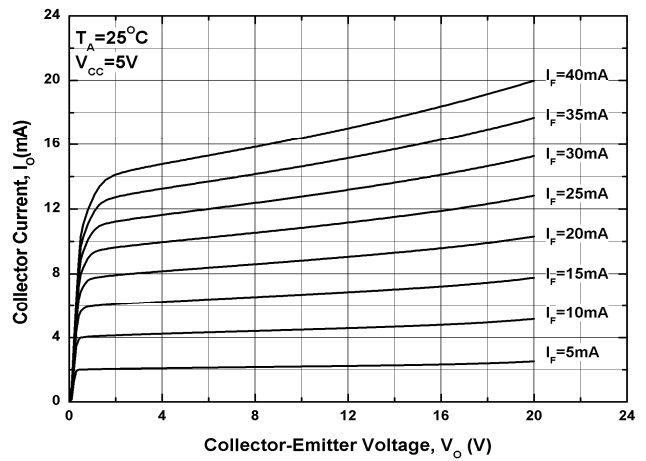

Figure 5. Logic High Output Current vs Ambient Temperature

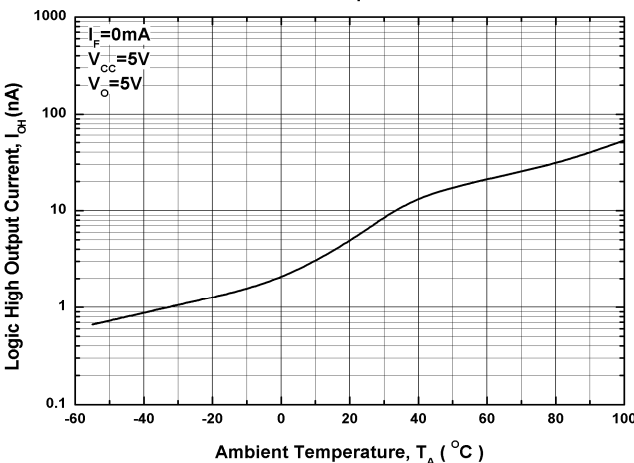
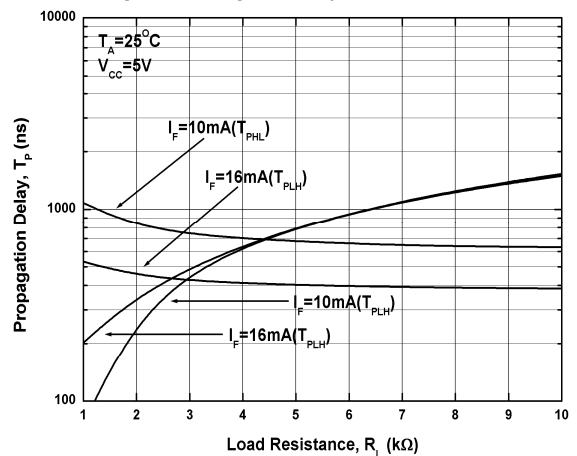

Figure 6. Propagation Delay vs. Load Resistance





LIGHTING FOREVER

8 PIN SOP HIGH SPEED 1Mbit/s TRANSISTOR PHOTOCOUPLER

EL045X EL050X series

Figure 7. Propagation Delay vs. Temperature

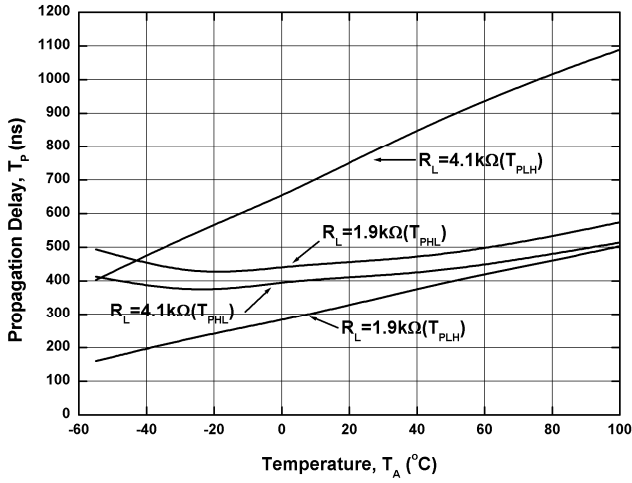

8 PIN SOP HIGH SPEED 1Mbit/s TRANSISTOR PHOTOCOUPLER

EL045X EL050X series

Figure 8 Switching Time Test Circuit & Waveform

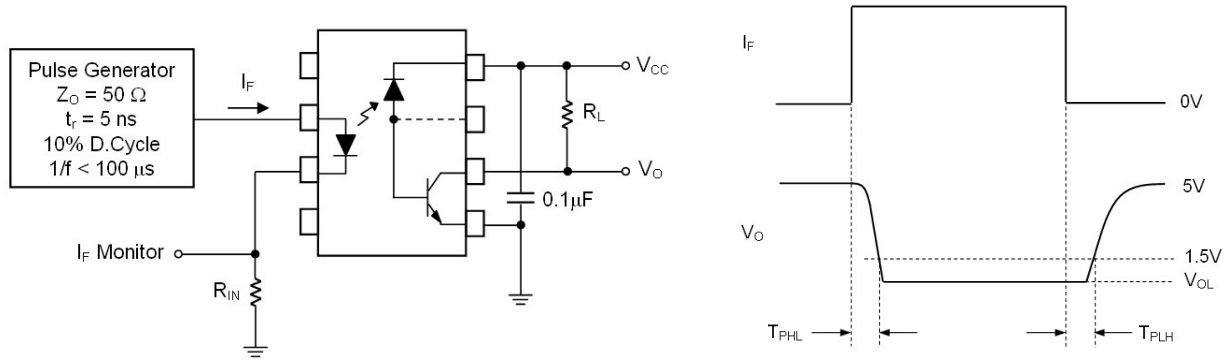
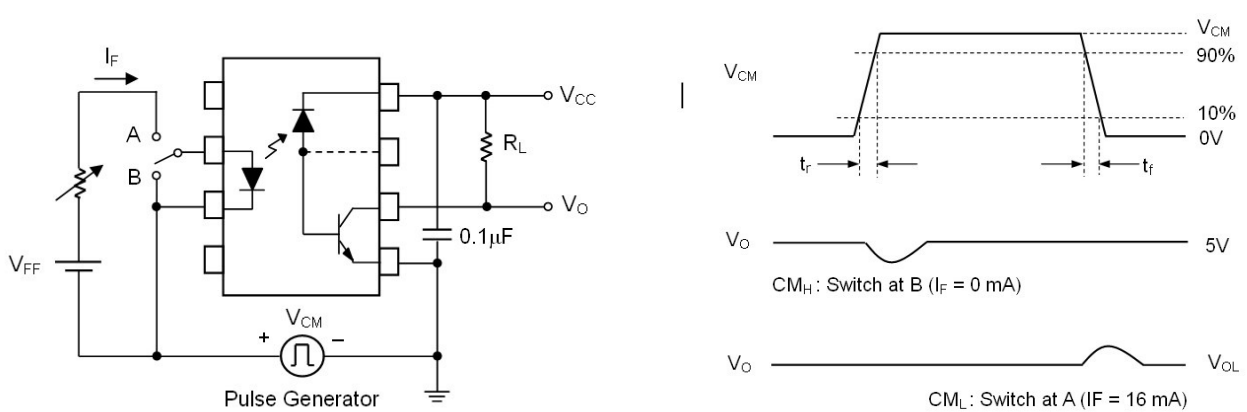

Figure 9 Transient Immunity Test Circuit & Waveform



Note:

*3 Common mode transient immunity in logic high level is the maximum tolerable (positive) dV_{cm}/dt on the leading edge of the common mode pulse signal V_{CM} , to assure that the output will remain in a logic high state (i.e., $V_O > 2.0V$).

Common mode transient immunity in logic low level is the maximum tolerable (negative) dV_{cm}/dt on the trailing edge of the common mode pulse signal, V_{CM} , to assure that the output will remain in a logic low state (i.e., $V_O < 0.8V$).



LIGHTING FOREVER

8 PIN SOP HIGH SPEED 1Mbit/s TRANSISTOR PHOTOCOUPLER

EL045X EL050X series

Order Information

Part Number

EL050X(Z)-V

Or

EL0452(Z)-V

Note

- X = Part No. (X = 0 or 1) for EL050x
- Z = Tape and reel option (TA, TB or none)
- V = VDE (optional)

Option	Description	Packing quantity
None	Standard	100 units per tube
-V	Standard + VDE	100 units per tube
(TA)	TA tape & reel option	2000 units per reel
(TB)	TB tape & reel option	2000 units per reel
(TA)-V	TA tape & reel option + VDE	2000 units per reel
(TB)-V	TB tape & reel option + VDE	2000 units per reel



LIGHTING FOREVER

8 PIN SOP HIGH SPEED 1Mbit/s TRANSISTOR PHOTOCOUPLER

EL045X EL050X series

Package Drawing (Dimensions in mm)

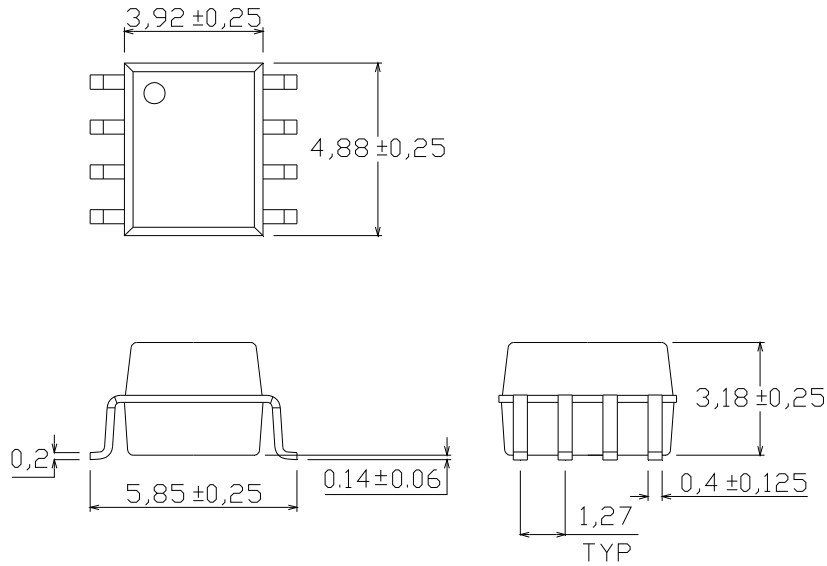

Recommended pad layout for surface mount leadform

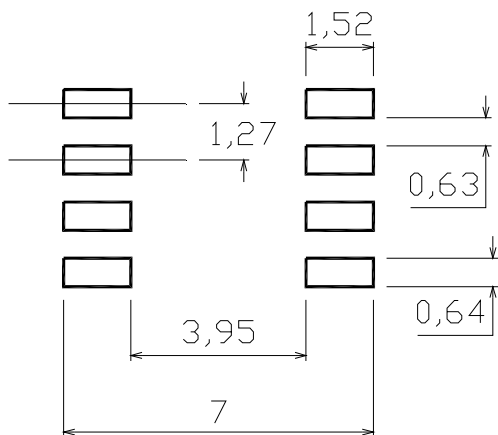



LIGHTING FOREVER

8 PIN SOP HIGH SPEED 1Mbit/s TRANSISTOR PHOTOCOUPLER

EL045X EL050X series

Device Marking

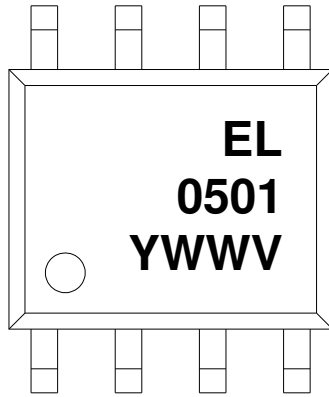

Notes

- EL denotes EVERLOGHT
- 0501 denotes Device Number
- Y denotes 1 digit Year code
- WW denotes 2 digit Week code
- V denotes VDE (optional)

**8 PIN SOP HIGH SPEED 1Mbit/s
TRANSISTOR PHOTOCOUPLER**

EL045X EL050X series

Tape & Reel Packing Specifications

Option TA

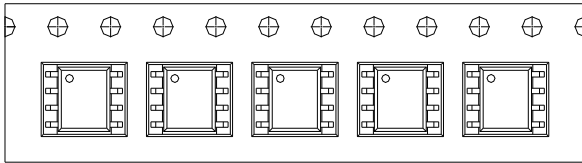

Option TB

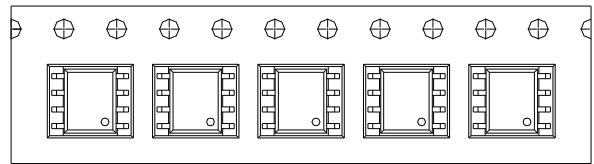

Direction of feed from reel



Direction of feed from reel

Tape dimensions

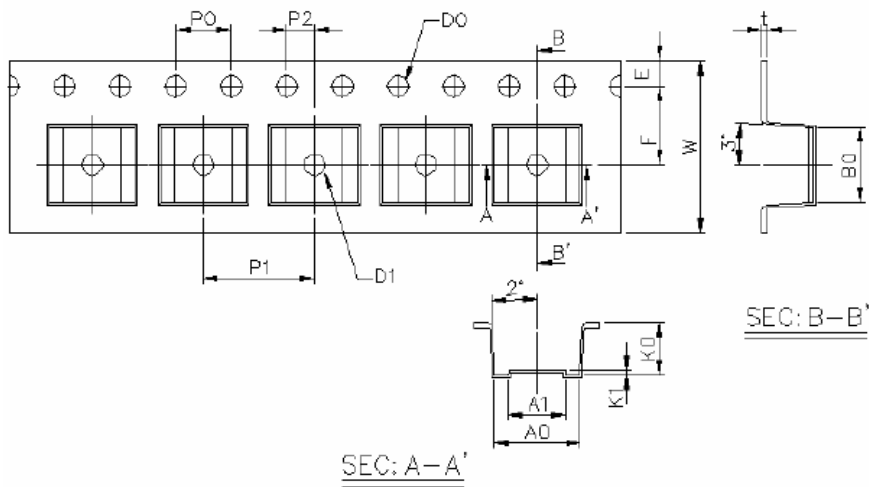

Dimension No.	A0	A1	B0	D0	D1	E	F
Dimension(mm)	6.2±0.1	4.1±0.1	5.28±0.1	1.5±0.1	1.5±0.3	1.75±0.1	5.5±0.1
Dimension No.	Po	P1	P2	t	W	K0	K1
Dimension(mm)	4.0±0.1	8.0±0.1	2.0±0.1	0.4±0.1	12.0+0.3/ -0.1	3.7±0.1	0.3±0.1



LIGHTING FOREVER

8 PIN SOP HIGH SPEED 1Mbit/s TRANSISTOR PHOTOCOUPLER

EL045X EL050X series

Solder Reflow Temperature Profile

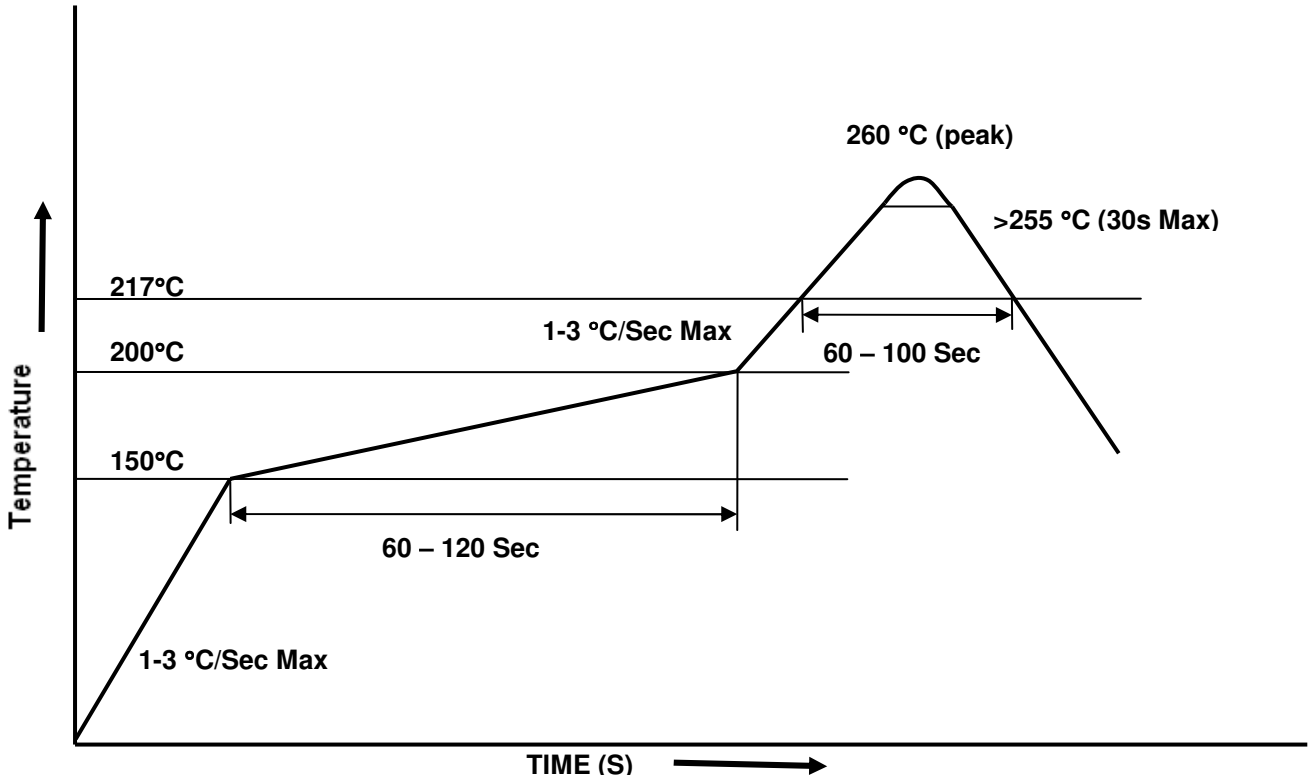



LIGHTING FOREVER

8 PIN SOP HIGH SPEED 1Mbit/s TRANSISTOR PHOTOCOUPLER

EL045X EL050X series

DISCLAIMER

1. Above specification may be changed without notice. EVERLIGHT will reserve authority on material change for above specification.
2. When using this product, please observe the absolute maximum ratings and the instructions for using outlined in these specification sheets. EVERLIGHT assumes no responsibility for any damage resulting from use of the product which does not comply with the absolute maximum ratings and the instructions included in these specification sheets.
3. These specification sheets include materials protected under copyright of EVERLIGHT corporation. Please don't reproduce or cause anyone to reproduce them without EVERLIGHT's consent.