

GELM317

3-TERMINAL 1A POSITIVE ADJUSTABLE VOLTAGE REGULATOR

Description

The GELM317 is an adjustable 3-terminal positive voltage regulator, designed to supply more than 1.5A of output current with voltage adjustable from 1.3 to 37V.

Features

- *Output current up to 1.5A.
- *Output voltage adjustable from 1.3V to 37V.
- *Internal short circuit protection.
- *Internal over temperature protection.
- *Safe-Area compensation for output transistor.

Package Dimensions

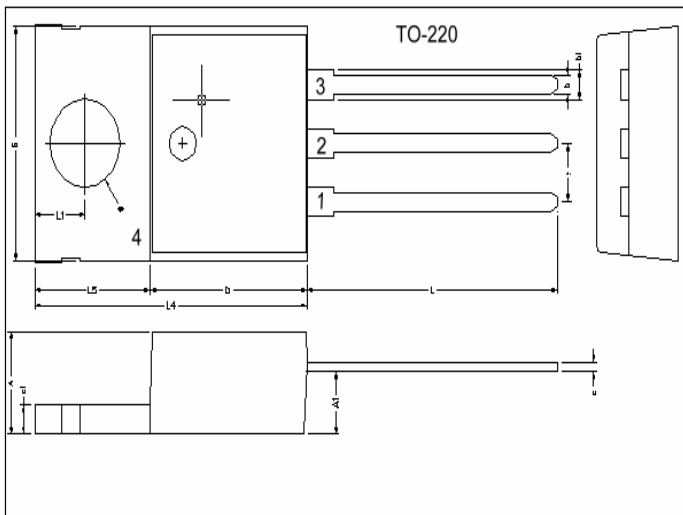

Marking :

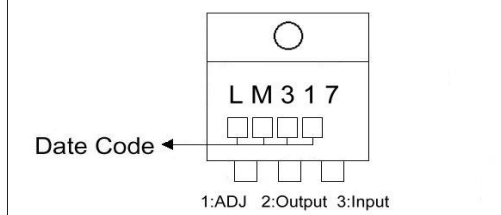

REF.	Millimeter		REF.	Millimeter	
	Min.	Max.		Min.	Max.
A	4.40	4.80	c1	1.25	1.45
b	0.76	1.0	b1	1.17	1.47
c	0.36	0.50	L	13.25	14.25
D	8.60	9.00	e	2.54 REF.	
E	9.80	10.4	L1	2.60	2.89
L4	14.7	15.3	∅	3.71	3.96
L5	6.20	6.60	A1	2.60	2.80

BLOCK DIAGRAM

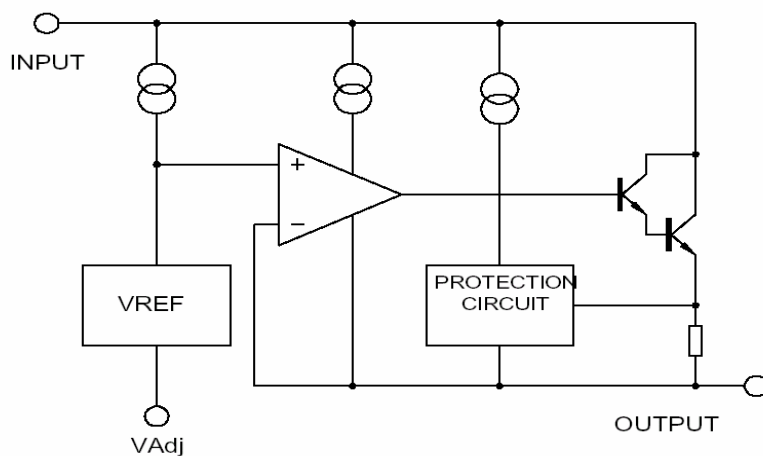

Absolute Maximum Ratings at Ta = 25°C

Parameter	Symbol	Ratings	Unit
Input-Output Voltage Difference	Vi-Vo	40	V
Load Temperature	TLEAD	230	°C
Power Dissipation	Pd	Internal limited	
Operating Temperature Range	TOPR	0~125	°C
Storage Temperature Range	TSTG	-65 ~ 150	°C

Electrical Characteristics at Ta = 25°C

(VI-VO=5V, 0°C < Tj < 125°C, IO=500mA, IMAX=1.5A, PMAX=20W, unless otherwise specified)

PARAMETER	Symbol	Test Conditions		TYPE	Max.	UNIT
Line Regulation	ΔVO	Ta=25°C, 3V<=VI-VO=40V		0.01	0.04	%V
		Ta=0-125°C, 3V<=VI-VO<=40V		0.02	0.07	%V
Load Regulation	ΔVO	Ta=25°C	VO<=6V	18	25	mV
		10mA<=IO<=IMAX	VO>=5V	0.4	0.5	%VO
		10mA<=IO<=IMAX	VO<=5V	40	70	mV
			VO>=6V	0.8	1.5	%VO
Adjustable Pin Current	IADJ			46	100	uA
Adjustable Pin Current Change	ΔIADJ	2.5V<=VI-VO<=40V , 10mA<=IO<=IMAX, PD<=PMAX		2.0	5	uA
Reference Voltage		3V<=VI-VO<=40V, 10mA<=IO<=IMAX, PD<=PMAX	1.20	1.25	1.30	V
Temperature Stability	STT			0.7		%VO
Minimum Load Current for Regulation	IL(MIN)	VI-VO=40V		3.5	10	mA
Maximum Output Current	IO(MAX)	VI-VO<=15V, PD<=PMAX	1.5	2.2		A
		VI-VO<=15V, PD<=PMAX, Ta=25°C	0.15	0.4		
RMS Noise v.s. %of Vout	eN	TA=25°C, 10HZ<=f<=10KHZ		0.003	0.01	%VO
Ripple Rejection	RR	VO=10V, f=120HZ,		60		dB
		VO=10V, f=120HZ, CADJ=10uF	66	75		
Long-term Stability, TJ=THIGH	ST	TA=25°C, 1000hr		0.3	1	%
Junction to Case Thermal Resistance	R θ JC			5		°C/W

*Note: Testing with low duty pulse should be used to avoid heating effect.

Characteristics Curve

Fig.1. Load Regulation vs temperature

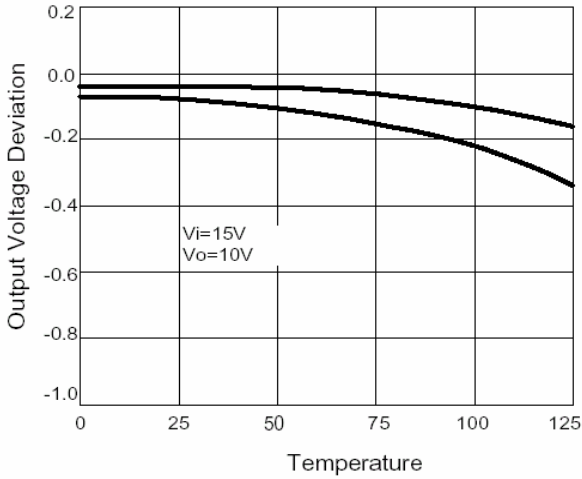

Fig.2 Adjustment Current vs Temperature

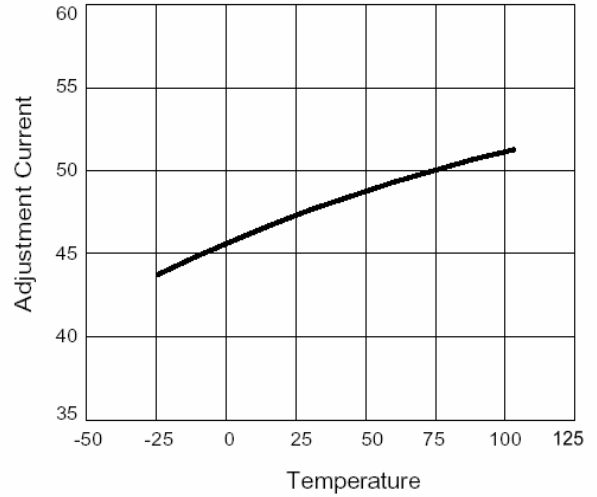

Fig.3. Dropout Voltage vs Input-Output Voltage Difference

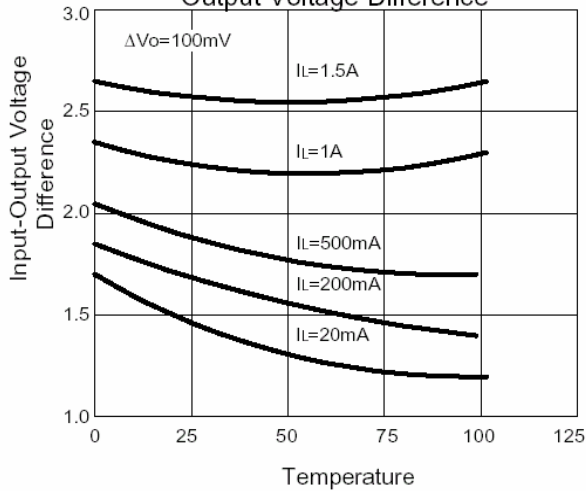
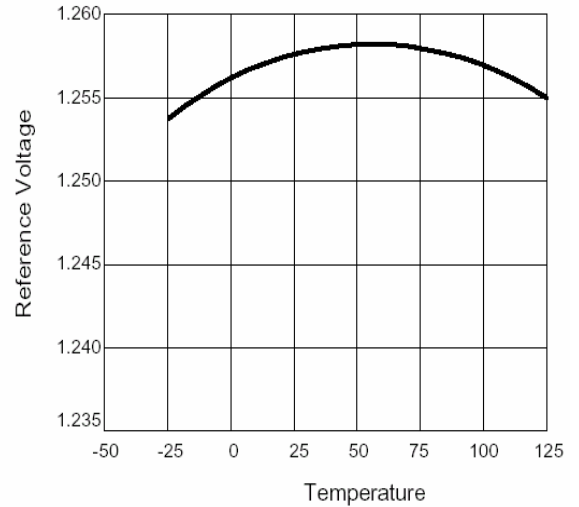

Fig.4 Reference Voltage vs Temperature



Application Circuit

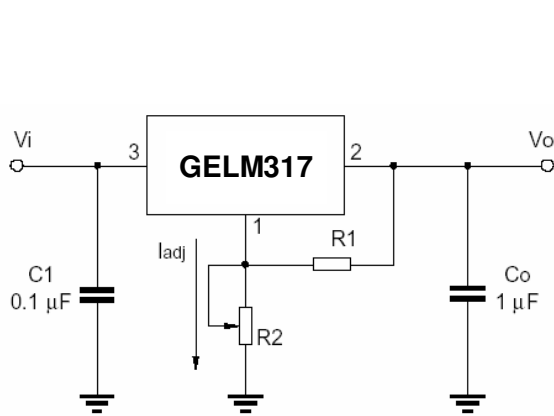

Fig.5 Programmable voltage regulator

$$V_o = 1.25V * (1 + R_2/R_1) + I_{adj} * R_2$$

C1 is required when regulator is located an appreciated distance from power supply. Co is needed to improve transient response.

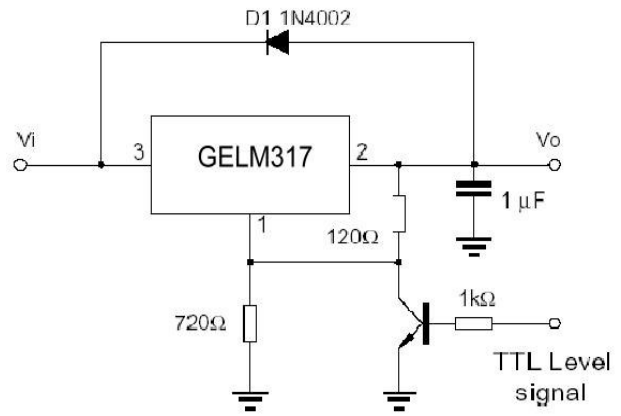

Fig.6 Regulator with On-off control

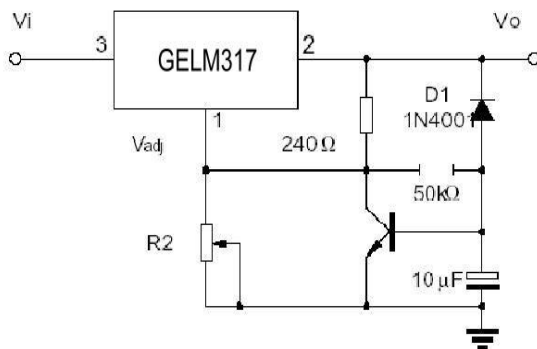
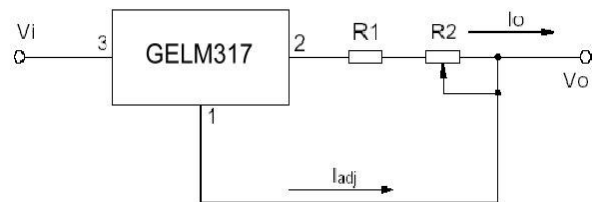

Fig.7 Soft start application



$$I_{o\max} = \left(\frac{V_{ref}}{R_1} \right) + I_{adj} = \frac{1.25V}{R_1}$$

$$I_{o\min} = \left(\frac{V_{ref}}{R_1 + R_2} \right) + I_{adj} = \frac{1.25V}{R_1 + R_2}$$

$$5mA < I_o < 100mA$$

Fig.8 Constant current application

Important Notice:

- All rights are reserved. Reproduction in whole or in part is prohibited without the prior written approval of GTM.
- GTM reserves the right to make changes to its products without notice.
- GTM semiconductor products are not warranted to be suitable for use in life-support Applications, or systems.
- GTM assumes no liability for any consequence of customer product design, infringement of patents, or application assistance.

Head Office And Factory:

- **Taiwan:** No. 17-1 Tatung Rd. Fu Kou Hsin-Chu Industrial Park, Hsin-Chu, Taiwan, R. O. C.
- TEL : 886-3-597-7061 FAX : 886-3-597-9220, 597-0785
- **China:** (201203) No.255, Jang-Jiang Tsai-Lueng RD. , Pu-Dung-Hsin District, Shang-Hai City, China
- TEL : 86-21-5895-7671 ~ 4 FAX : 86-21-38950165