

16-bit Proprietary Microcontroller

CMOS

F²MC-16LX MB90455 Series

MB90F455 (S) /F456 (S) /F457 (S) MB90455 (S) /456 (S) /457 (S) /V495G

■ DESCRIPTION

MB90455 series devices are general-purpose high-performance 16-bit micro controllers designed for process control of consumer products, which require high-speed real-time processing.

The system, inheriting the architecture of F²MC* family, employs additional instruction ready for high-level languages, expanded addressing mode, enhanced multiply-divide instructions, and enriched bit-processing instructions. Furthermore, employment of 32-bit accumulator achieves processing of long-word data (32 bits).

The peripheral resources of MB90455 series include the following:

8/10-bit A/D converter, UART 1, 8/16-bit PPG timer, 16-bit input-output timer (16-bit free-run timer, input capture 0, 1, 2, 3 (ICU)).

*: "F²MC", an abbreviation for FUJITSU Flexible Microcontroller, is a registered trademark of FUJITSU Ltd.

■ FEATURES

• Clock

- Built-in PLL clock frequency multiplication circuit
- Selection of machine clocks (PLL clocks) is allowed among frequency division by two on oscillation clock, and multiplication of 1 to 4 times of oscillation clock (for 4-MHz oscillation clock, 4 MHz to 16 MHz).
- Operation by sub-clock (8.192 kHz) is allowed.
- Minimum execution time of instruction: 62.5 ns (when operating with 4-MHz oscillation clock, and 4-time multiplied PLL clock).

(Continued)

■ PACKAGE

48-pin plastic-LQFP

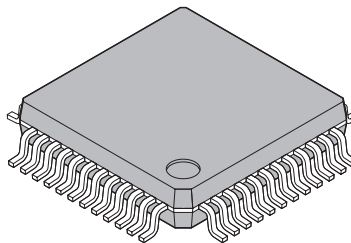

(FPT-48P-M26)

MB90455 Series

- **16 Mbyte CPU memory space**
 - 24-bit internal addressing
- **Instruction system best suited to controller**
 - Wide choice of data types (bit, byte, word, and long word)
 - Wide choice of addressing modes (23 types)
 - Enhanced multiply-divide instructions and RETI instructions
 - Enhanced high-precision computing with 32-bit accumulator
- **Instruction system compatible with high-level language (C language) and multitask**
 - Employing system stack pointer
 - Enhanced various pointer indirect instructions
 - Barrel shift instructions
- **Increased processing speed**
 - 4-byte instruction queue
- **Powerful interrupt function with 8 levels and 34 factors**
- **Automatic data transfer function independent of CPU**
 - Expanded intelligent I/O service function (EI² OS): Maximum of 16 channels
- **Low power consumption (standby) mode**
 - Sleep mode (a mode that halts CPU operating clock)
 - Time-base timer mode (a mode that operates oscillation clock, sub clock, time-base timer and clock timer only)
 - Clock mode (a mode that operates sub clock and clock timer only)
 - Stop mode (a mode that stops oscillation clock and sub clock)
 - CPU blocking operation mode
- **Process**
 - CMOS technology
- **I/O port**
 - General-purpose input/output port (CMOS output): 34 ports(MB90F455/F456/F457, MB90455/456/457) (including 4 high-current output ports) (When sub clock is not used, 36 ports(MB90F455S/F456S/F457S, MB90455S/456S/457S))
- **Timer**
 - Time-base timer, clock timer, watchdog timer: 1 channel
 - 8/16-bit PPG timer: 8-bit x 4 channels, or 16-bit x 2 channels
 - 16-bit reload timer: 2 channels
 - 16-bit input/output timer
 - 16-bit free run timer: 1 channel
 - 16-bit input capture: (ICU): 4 channelsInterrupt request is issued upon latching a count value of 16-bit free run timer by detection of an edge on pin input.
- **UART 1: 1 channel**
 - Equipped with full-duplex double buffer
 - Clock-asynchronous or clock-synchronous serial transmission is available

(Continued)

(Continued)

- **DTP/External interrupt: 4 channels**

- Module for activation of expanded intelligent I/O service (EI²OS), and generation of external interrupt.

- **Delay interrupt generator module**

- Generates interrupt request for task switching.

- **8/10-bit A/D converter: 8 channels**

- Resolution is selectable between 8-bit and 10-bit.
- Activation by external trigger input is allowed.
- Conversion time: 6.125 μ s (at 16-MHz machine clock, including sampling time)

- **Program patch function**

- Address matching detection for 2 address pointers.

MB90455 Series

■ PRODUCT LINEUP

Part Number Parameter	MB90F455 (S) / F456 (S) /F457 (S)	MB90455 (S) / 456 (S) /457 (S)	MB90V495G
Classification	Flash ROM	Mask ROM	Evaluation product
ROM capacity	MB90F455 (S) : 24 Kbytes MB90F456 (S) : 32 Kbytes MB90F457 (S) : 64 Kbytes	MB90455 (S) : 24 Kbytes MB90456 (S) : 32 Kbytes MB90457 (S) : 64 Kbytes	—
RAM capacity	2 Kbytes		6 Kbytes
Clock	MB90F455/F456/F457 : 2 systems MB90F455S/F456S/F457S : 1 system	MB90455/456/457 : 2 systems MB90455S/456S/457S : 1 system	2 systems
Process	CMOS		
Package	LQFP-48 (0.50 mm width)		PGA256
Operating power supply voltage	3.5 V to 5.5 V		4.5 V to 5.5 V
Special power supply for emulator*1	—		None
CPU functions	Number of basic instructions : 351 instructions Instruction bit length : 8 bits and 16 bits Instruction length : 1 byte to 7 bytes Data bit length : 1 bit, 8 bits, 16 bits		
	Minimum instruction execution time : 62.5 ns (at 16-MHz machine clock)		
	Interrupt processing time : 1.5 μs at minimum (at 16-MHz machine clock)		
Low power consumption (standby) mode	Sleep mode/Clock mode/Time-base timer mode/ Stop mode/CPU intermittent		
I/O port	General-purpose input/output ports (CMOS output) : 34 ports (36 ports*2) including 4 high-current output ports (P14 to P17)		
Time-base timer	18-bit free-run counter Interrupt cycle : 1.024 ms, 4.096 ms, 16.834 ms, 131.072 ms (with oscillation clock frequency at 4 MHz)		
Watchdog timer	Reset generation cycle: 3.58 ms, 14.33 ms, 57.23 ms, 458.75 ms (with oscillation clock frequency at 4 MHz)		
16-bit input/ output timer	16-bit free-run timer	Number of channels: 1 Interrupt upon occurrence of overflow	
	Input capture	Number of channels: 4 Retaining free-run timer value set by pin input (rising edge, falling edge, and both edges)	
16-bit reload timer	Number of channels: 2 16-bit reload timer operation Count clock cycle: 0.25 μs, 0.5 μs, 2.0 μs (at 16-MHz machine clock frequency) External event count is allowed.		
Clock timer	15-bit free-run counter Interrupt cycle: 31.25 ms, 62.5 ms, 12 ms, 250 ms, 500 ms, 1.0 s, 2.0 s (with 8.192 kHz sub clock)		

(Continued)

MB90455 Series

(Continued)

Part Number Parameter	MB90F455 (S) / F456 (S) /F457 (S)	MB90455 (S) / 456 (S) /457 (S)	MB90V495G
8/16-bit PPG timer	Number of channels: 2 (four 8-bit channels are available also) PPG operation is allowed with four 8-bit channels or one 16-bit channel. Outputting pulse wave of arbitrary cycle or arbitrary duty is allowed. Count clock: 62.5 ns to 1 μ s (with 16 MHz machine clock)		
Delay interrupt generator module	Interrupt generator module for task switching. Used for Real-time OS.		
DTP/External interrupt	Number of inputs: 4 Activated by rising edge, falling edge, "H" level or "L" level input. External interrupt or expanded intelligent I/O service (EI ² OS) is available.		
8/10-bit A/D converter	Number of channels: 8 Resolution: Selectable 10-bit or 8-bit. Conversion time: 6.125 μ s (at 16-MHz machine clock, including sampling time) Sequential conversion of two or more successive channels is allowed. (Setting a maximum of 8 channels is allowed.) Single conversion mode : Selected channel is converted only once. Sequential conversion mode: Selected channel is converted repetitively. Halt conversion mode : Conversion of selected channel is stopped and activated alternately.		
UART 1	Number of channels: 1 Clock-synchronous transfer: 62.5 Kbps to 2 Mbps Clock-asynchronous transfer: 9,615 bps to 500 Kbps Communication is allowed by bi-directional serial communication function and master/slave type connection.		

*1 : Settings of DIP switch S2 for using emulation pod MB2145-507. For details, See MB2145-507 Hardware Manual (2.7 Power Pin solely for Emulator).

*2 : MB90F455S/F456S/F457S, MB90455S/456S/457S

MB90455 Series

■ PACKAGES AND PRODUCT MODELS

Package	MB90F455 (S)/F456 (S)/F457 (S)	MB90455 (S) /456 (S) /457 (S)
FPT-48P-M26	○	○

○ : Yes × : No

Note : Refer to “■ PACKAGE DIMENSION” for details of the package.

■ PRODUCT COMPARISON

Memory space

When testing with test product for evaluation, check the differences between the product and a product to be used actually. Pay attention to the following points:

- The MB90V495G has no built-in ROM. However, a special-purpose development tool allows the operations as those of one with built-in ROM. ROM capacity depends on settings on a development tool.
- On MB90V495G, an image from FF4000_H to FFFFFFF_H is viewed on 00 bank and an image of FE0000_H to FF3FFF_H is viewed only on FE bank and FF bank. (Modified on settings of a development tool.)
- On MB90F455 (S) /F456 (S) /F457 (S) , MB90455 (S) /456 (S) /457 (S) , an image from FF4000_H to FFFFFFF_H is viewed on 00 bank and an image of FE0000_H to FF3FFF_H is viewed only on FF bank.

PIN ASSIGNMENT

(TOP VIEW)

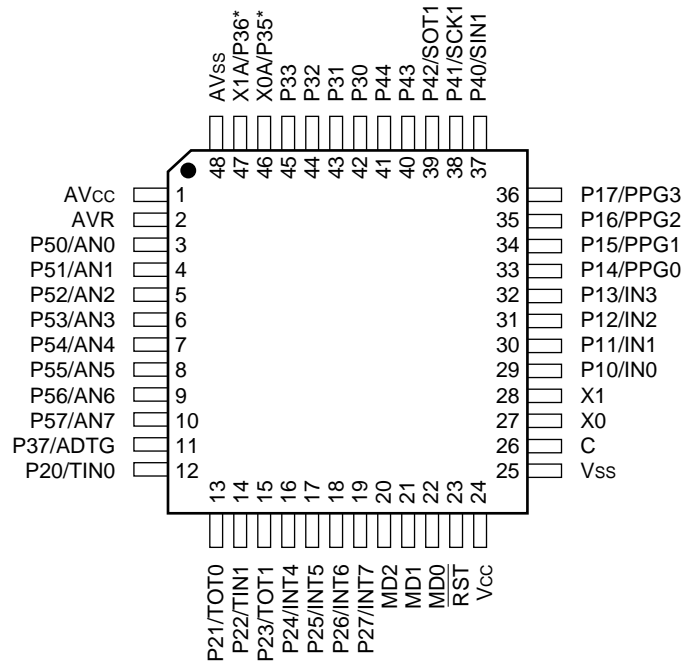

(FPT-48P-M26)

* : MB90F455/F456/F457, MB90455/456/457 : X1A, X0A
 MB90F455S/F456S/F457S, MB90455S/456S/457S : P36, P35

MB90455 Series

■ PIN DESCRIPTION

Pin No.	Pin name	Circuit format	Description
1	AVcc	—	Vcc power input pin for A/D converter
2	AVR	—	Power (Vref+) input pin for A/D converter. Use as input for Vcc or lower.
3 to 10	P50 to P57	E	General-purpose input/output ports.
	AN0 to AN7		Functions as an analog input pin for A/D converter. Valid when analog input setting is “enabled.”
11	P37	D	General-purpose input/output port.
	ADTG		Function as an external trigger input pin for A/D converter. Use the pin by setting as input port.
12	P20	D	General-purpose input/output port.
	TIN0		Function as an event input pin for reload timer 0. Use the pin by setting as input port.
13	P21	D	General-purpose input/output port.
	TOT0		Function as an event output pin for reload timer 0. Valid only when output setting is “enabled.”
14	P22	D	General-purpose input/output port.
	TIN1		Function as an event input pin for reload timer 1. Use the pin by setting as input port.
15	P23	D	General-purpose input/output port.
	TOT1		Function as an event output pin for reload timer 1. Valid only when output setting is “enabled.”
16 to 19	P24 to P27	D	General-purpose input/output ports.
	INT4 to INT7		Functions as an external interrupt input pin. Use the pin by setting as input port.
20	MD2	F	Input pin for specifying operation mode. Connect directly to Vss.
21	MD1	C	Input pin for specifying operation mode. Connect directly to Vcc.
22	MD0	C	Input pin for specifying operation mode. Connect directly to Vcc.
23	RST	B	External reset input pin.
24	Vcc	—	Power source (5 V) input pin.
25	Vss	—	Power source (0 V) input pin.
26	C	—	Capacitor pin for stabilizing power source. Connect a ceramic capacitor of approximately 0.1 μ F.
27	X0	A	Pin for high-rate oscillation.
28	X1	A	Pin for high-rate oscillation.
29 to 32	P10 to P13	D	General-purpose input/output ports.
	IN0 to IN3		Functions as trigger input pins of input capture channels 0 to 3. Use the pins by setting as input ports.

(Continued)

MB90455 Series

(Continued)

Pin No.	Pin name	Circuit format	Description
33 to 36	P14 to P17	G	General-purpose input/output ports. High-current output ports.
	PPG0 to PPG3		Functions as output pins of PPG timers 01 and 23. Valid when output setting is "enabled."
37	P40	D	General-purpose input/output port.
	SIN1		Serial data input pin for UART. Use the pin by setting as input port.
38	P41	D	General-purpose input/output port.
	SCK1		Serial clock input pin for UART. Valid only when serial clock input/output setting on UART is "enabled."
39	P42	D	General-purpose input/output port.
	SOT1		Serial data input pin for UART. Valid only when serial data input/output setting on UART is "enabled."
40	P43	D	General-purpose input/output port.
41	P44	D	General-purpose input/output port.
42 to 45	P30 to P33	D	General-purpose input/output ports.
46	X0A*	A	Pin for low-rate oscillation.
	P35*		General-purpose input/output port.
47	X1A*	A	Pin for low-rate oscillation.
	P36*		General-purpose input/output port.
48	AVss	—	Vss power source input pin for A/D converter.

* : MB90F455/F456/F457, MB90455/456/457 : X1A, X0A
 MB90F455S/F456S/F457S, MB90455S/456S/457S : P36, P35

MB90455 Series

■ I/O CIRCUIT TYPE

Type	Circuit	Remarks
A		<ul style="list-style-type: none"> • High-rate oscillation feedback resistor, approx.1 MΩ • Low-rate oscillation feedback resistor, approx.10 MΩ
B		<ul style="list-style-type: none"> • Hysteresis input with pull-up resistor. • Pull-up resistor, approx.50 kΩ
C		<ul style="list-style-type: none"> • Hysteresis input
D		<ul style="list-style-type: none"> • CMOS hysteresis input • CMOS level output • Standby control provided
E		<ul style="list-style-type: none"> • CMOS hysteresis input • CMOS level output • Shared for analog input pin • Standby control provided

(Continued)

(Continued)

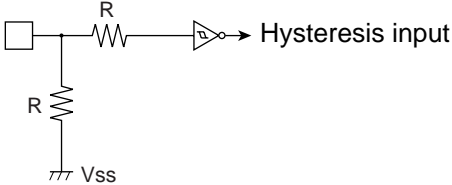
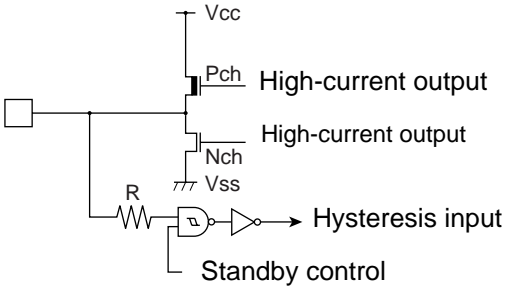
Type	Circuit	Remarks
F		<ul style="list-style-type: none"> • Hysteresis input with pull-down resistor • Pull-down resistor, approx. 50 kΩ • FLASH product is not provided with pull-down resistor.
G		<ul style="list-style-type: none"> • CMOS hysteresis input • CMOS level output (high-current output) • Standby control provided

MB90455 Series

■ HANDLING DEVICES

• Do not exceed maximum rating (preventing “latch up”)

- On a CMOS IC, latch-up may occur when applying a voltage higher than V_{cc} or a voltage lower than V_{ss} to input or output pin, which has no middle or high withstand voltage. Latch-up may also occur when a voltage exceeding maximum rating is applied across V_{cc} and V_{ss} .
- Latch-up causes drastic increase of power current, which may lead to destruction of elements by heat. Extreme caution must be taken not to exceed maximum rating.
- When turning on and off analog power source, take extra care not to apply an analog power voltages (AV_{cc} and AVR) and analog input voltage that are higher than digital power voltage (V_{cc}).

• Handling unused pins

- Leaving unused input pins open may cause permanent destruction by malfunction or latch-up. Apply pull-up or pull-down process to the unused pins using resistors of 2 k Ω or higher. Leave unused input pins open under output status, or process as input pins if they are under input status.

• Using external clock

- When using an external clock, drive only X0 pin and leave X1 pin open. An example of using an external clock is shown below.

Using external clock

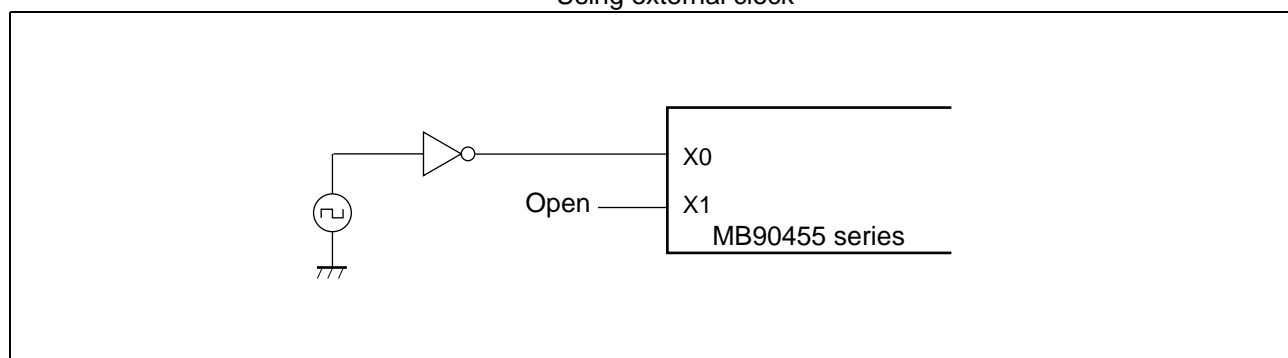

• Notes when using no sub clock

- If an oscillator is not connected to X0A and X1A pin, apply pull-down resistor to X0A pin and leave X1A pin open.

• About power supply pins

- If two or more V_{cc} and V_{ss} exist, the pins that should be at the same potential are connected to each other inside the device. For reducing unwanted emissions and preventing malfunction of strobe signals caused by increase of ground level, however, be sure to connect the V_{cc} and V_{ss} pins to the power source and the ground externally.
- Pay attention to connect a power supply to V_{cc} and V_{ss} of MB90455 series device in a lowest-possible impedance.
- Near pins of MB90455 series device, connecting a bypass capacitor is recommended at 0.1 μF across V_{cc} and V_{ss} .

• Crystal oscillator circuit

- Noises around X0 and X1 pins cause malfunctions on a MB90455 series device. Design a print circuit so that X0 and X1 pins, an crystal oscillator (or a ceramic oscillator), and bypass capacitor to the ground become as close as possible to each other. Furthermore, avoid wires to X0 and X1 pins crossing each other as much as possible.
- Print circuit designing that surrounds X0 and X1 pins with grounding wires, which ensures stable operation, is strongly recommended.

- **Caution on Operations during PLL Clock Mode**

- If the PLL clock mode is selected, the microcontroller attempt to be working with the self-oscillating circuit even when there is no external oscillator or external clock input is stopped. Performance of this operation, however, cannot be guaranteed.

- **Sequence of turning on power of A/D converter and applying analog input**

- Be sure to turn on digital power (V_{CC}) before applying signals to the A/D converter and applying analog input signals (AN0 to AN7 pins).
- Be sure to turn off the power of A/D converter and analog input before turning off the digital power source.
- Be sure not to apply AVR exceeding AV_{CC} when turning on and off. (No problems occur if analog and digital power is turned on and off simultaneously.)

- **Handling pins when A/D converter is not used**

- If the A/D converter is not used, connect the pins under the following conditions: " $AV_{CC}=AVR=V_{CC}$," and " $AV_{SS}=V_{SS}$ "

- **Note on turning on power**

- For preventing malfunctions on built-in step-down circuit, maintain a minimum of 50 μ s of voltage rising time (between 0.2 V and 2.7 V) when turning on the power.

- **Stabilization of supply voltage**

- A sudden change in the supply voltage may cause the device to malfunction even within the specified V_{CC} supply voltage operating range. Therefore, the V_{CC} supply voltage should be stabilized. For reference, the supply voltage should be controlled so that V_{CC} ripple variations (peak-to-peak values) at commercial frequencies (50 Hz to 60 Hz) fall below 10% of the standard V_{CC} supply voltage and the coefficient of fluctuation does not exceed 0.1 V/ms at instantaneous power switching.

MB90455 Series

■ BLOCK DIAGRAM

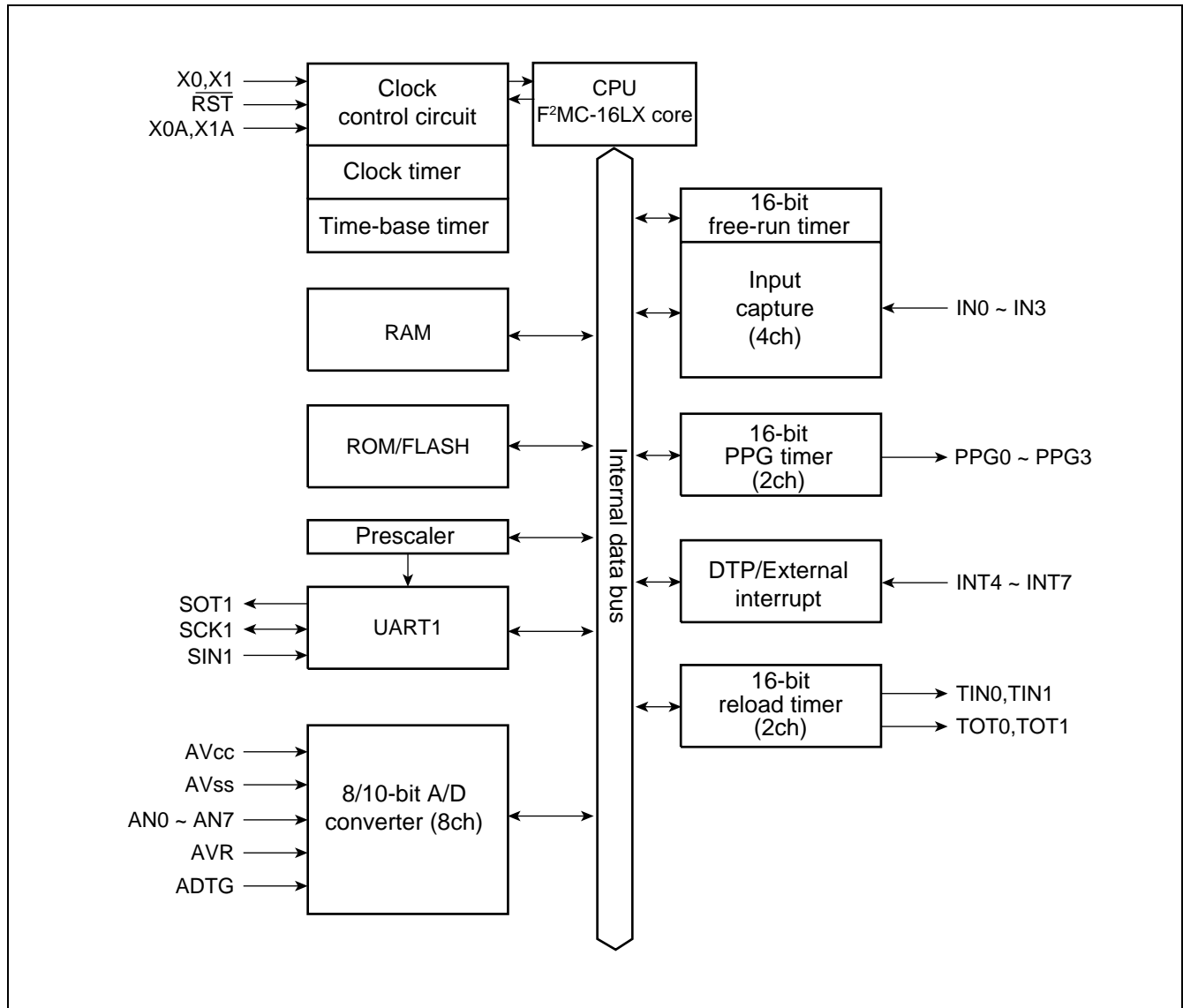

MEMORY MAP

MB90455 series allows specifying a memory access mode “single chip mode.”



1. Memory allocation of MB90455

MB90455 series model has 24-bit wide internal address bus and up to 24-bit bus of external address bus. A maximum of 16 Mbyte memory space of external access memory is accessible.

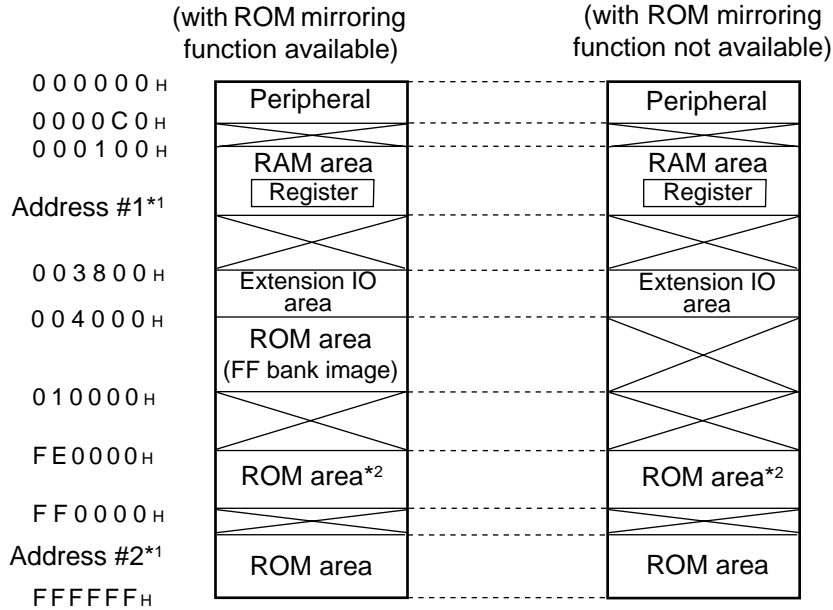
2. Memory map



Product	Address #1*1	Address #2*1
MB90F455 (S) /455 (S)	000900H	FFA000H
MB90F456 (S) /456 (S)	000900H	FF8000H
MB90F457 (S) /457 (S)	000900H	FF0000H
MB90V495G	001900H	—

 : Internal access memory
 : Access disallowed

*1 : Addresses #1 and #3 are product-specific.

*2 : On MB90F455 (S) /F456 (S) /F457 (S) , 455 (S) /456 (S) /457 (S) , to read “FE0000H” to “FFFFFFH” is to read out “FF0000H” to “FFFFFFH”.

Note : When internal ROM is operating, F²MC-16LX allows viewing ROM data image on FF bank at upper-level of 00 bank. This function is called “mirroring ROM,” which allows effective use of C compiler small model. F²MC-16LX assigns the same low order 16-bit address to FF bank and 00 bank, which allows referencing table in ROM without specifying “far” using pointer. For example, when accessing to “00C000H”, ROM data at “FFC000H” is accessed actually. However, because ROM area of FF bank exceeds 48 Kbytes, viewing all areas is not possible on 00 bank image. Because ROM data of “FF4000H” to “FFFFFFH” is viewed on “004000H” to “00FFFFH” image, store a ROM data table in area “FF4000H” to “FFFFFFH.”

MB90455 Series

■ I/O MAP

Address	Register abbreviation	Register name	Reset value	Peripheral function name	Read/Write
000000 _H	(Reserved area) *				
000001 _H	PDR1	Port 1 data register	XXXXXXXX _B	Port 1	R/W
000002 _H	PDR2	Port 2 data register	XXXXXXXX _B	Port 2	R/W
000003 _H	PDR3	Port 3 data register	XXXXXXXX _B	Port 3	R/W
000004 _H	PDR4	Port 4 data register	XXXXXXXX _B	Port 4	R/W
000005 _H	PDR5	Port 5 data register	XXXXXXXX _B	Port 5	R/W
000006 _H to 000010 _H	(Reserved area) *				
000011 _H	DDR1	Port 1 direction data register	00000000 _B	Port 1	R/W
000012 _H	DDR2	Port 2 direction data register	00000000 _B	Port 2	R/W
000013 _H	DDR3	Port 3 direction data register	000X0000 _B	Port 3	R/W
000014 _H	DDR4	Port 4 direction data register	XXX00000 _B	Port 4	R/W
000015 _H	DDR5	Port 5 direction data register	00000000 _B	Port 5	R/W
000016 _H to 00001A _H	(Reserved area) *				
00001B _H	ADER	Analog input permission register	11111111 _B	8/10-bit A/D converter	R/W
00001C _H to 000025 _H	(Reserved area) *				
000026 _H	SMR1	Serial mode register 1	00000000 _B	UART1	R/W
000027 _H	SCR1	Serial control register 1	00000100 _B		R/W, W
000028 _H	SIDR1/ SODR1	Serial input data register 1/ Serial output data register 1	XXXXXXXX _B		R, W
000029 _H	SSR1	Serial status data register 1	00001000 _B		R, R/W
00002A _H	(Reserved area) *				
00002B _H	CDCR1	Communication prescaler control register 1	0XXX0000 _B	UART1	R/W
00002C _H to 00002F _H	(Reserved area) *				
000030 _H	ENIR	DTP/External interrupt permission register	00000000 _B	DTP/External interrupt	R/W
000031 _H	EIRR	DTP/External interrupt permission register	XXXXXXXX _B		R/W
000032 _H	(Reserved area) *				
000033 _H	ELVR	Detection level setting register	00000000 _B	DTP/External interrupt	R/W

(Continued)

MB90455 Series

Address	Register abbreviation	Register name	Reset value	Peripheral function name	Read/Write
000034 _H	ADCS	A/D control status register	00000000 _B	8/10-bit A/D converter	R/W
000035 _H			00000000 _B		R/W, W
000036 _H	ADCR	A/D data register	XXXXXXXX _B		W, R
000037 _H			00101XXX _B		R
000038 _H to 00003F _H	(Reserved area) *				
000040 _H	PPGC0	PPG0 operation mode control register	0X000XX1 _B	8/16-bit PPG timer 0/1	R/W, W
000041 _H	PPGC1	PPG1 operation mode control register	0X000001 _B		R/W, W
000042 _H	PPG01	PPG0/1 count clock selection register	000000XX _B		R/W
000043 _H	(Reserved area) *				
000044 _H	PPGC2	PPG2 operation mode control register	0X000XX1 _B	8/16-bit PPG timer 2/3	R/W, W
000045 _H	PPGC3	PPG3 operation mode control register	0X000001 _B		R/W, W
000046 _H	PPG23	PPG2/3 count clock selection register	000000XX _B		R/W
000047 _H to 00004F _H	(Reserved area) *				
000050 _H	IPCP0	Input capture data register 0	XXXXXXXX _B	16-bit input/output timer	R
000051 _H			XXXXXXXX _B		
000052 _H	IPCP1	Input capture data register 1	XXXXXXXX _B		R
000053 _H			XXXXXXXX _B		
000054 _H	ICS01	Input capture control status register	00000000 _B		R/W
000055 _H	ICS23		00000000 _B		
000056 _H	TCDT	Timer counter data register	00000000 _B		R/W
000057 _H			00000000 _B		
000058 _H	TCCS	Timer counter control status register	00000000 _B	R/W	
000059 _H	(Reserved area) *				
00005A _H	IPCP2	Input capture data register 2	XXXXXXXX _B	16-bit input/output timer	R
00005B _H			XXXXXXXX _B		
00005C _H	IPCP3	Input capture data register 3	XXXXXXXX _B		R
00005D _H			XXXXXXXX _B		

(Continued)

MB90455 Series

Address	Register abbreviation	Register name	Reset value	Peripheral function name	Read/Write
00005E _H to 000065 _H	(Reserved area) *				
000066 _H	TMCSR0	Timer control status register	00000000 _B	16-bit reload timer 0	R/W
000067 _H			XXXX0000 _B		R/W
000068 _H	TMCSR1		00000000 _B	16-bit reload timer 1	R/W
000069 _H			XXXX0000 _B		R/W
00006A _H to 00006E _H	(Reserved area) *				
00006F _H	ROMM	ROM mirroring function selection register	XXXXXXXX1 _B	ROM mirroring function selection module	W
000070 _H to 00007F _H	(Reserved area) *				
000080 _H to 00008F _H	(Reserved area) *				
000090 _H to 00009D _H	(Reserved area) *				
00009E _H	PACSR	Address detection control register	00000000 _B	Address matching detection function	R/W
00009F _H	DIRR	Delay interrupt request generation/release register	XXXXXXXX0 _B	Delay interrupt generation module	R/W
0000A0 _H	LPMCR	Low power consumption mode control register	00011000 _B	Low power consumption mode	W,R/W
0000A1 _H	CKSCR	Clock selection register	11111100 _B	Clock	R,R/W
0000A2 _H to 0000A7 _H	(Reserved area) *				
0000A8 _H	WDTC	Watchdog timer control register	XXXXX111 _B	Watchdog timer	R,W
0000A9 _H	TBTC	Time-base timer control register	1XX00100 _B	Time-base timer	R/W,W
0000AA _H	WTC	Clock timer control register	1X001000 _B	Clock timer	R,R/W
0000AB _H to 0000AD _H	(Reserved area) *				

(Continued)

MB90455 Series

Address	Register abbreviation	Register name	Reset value	Peripheral function name	Read/Write
0000AE _H	FMCS	Flash memory control status register	000X0000 _B	512 k-bit flash memory	R,W,R/W
0000AF _H	(Reserved area) *				
0000B0 _H	ICR00	Interrupt control register 00	00000111 _B	Interrupt controller	R/W
0000B1 _H	ICR01	Interrupt control register 01	00000111 _B		
0000B2 _H	ICR02	Interrupt control register 02	00000111 _B		
0000B3 _H	ICR03	Interrupt control register 03	00000111 _B		
0000B4 _H	ICR04	Interrupt control register 04	00000111 _B		
0000B5 _H	ICR05	Interrupt control register 05	00000111 _B		
0000B6 _H	ICR06	Interrupt control register 06	00000111 _B		
0000B7 _H	ICR07	Interrupt control register 07	00000111 _B		
0000B8 _H	ICR08	Interrupt control register 08	00000111 _B		
0000B9 _H	ICR09	Interrupt control register 09	00000111 _B		
0000BA _H	ICR10	Interrupt control register 10	00000111 _B		
0000BB _H	ICR11	Interrupt control register 11	00000111 _B		
0000BC _H	ICR12	Interrupt control register 12	00000111 _B		
0000BD _H	ICR13	Interrupt control register 13	00000111 _B		
0000BE _H	ICR14	Interrupt control register 14	00000111 _B		
0000BF _H	ICR15	Interrupt control register 15	00000111 _B		
0000C0 _H to 0000FF _H	(Reserved area) *				
001FF0 _H	PADR0	Detection address setting register 0 (low-order)	XXXXXXXX _B	Address matching detection function	R/W
001FF1 _H		Detection address setting register 0 (middle-order)	XXXXXXXX _B		
001FF2 _H		Detection address setting register 0 (high-order)	XXXXXXXX _B		
001FF3 _H	PADR1	Detection address setting register 1 (low-order)	XXXXXXXX _B		R/W
001FF4 _H		Detection address setting register 1 (middle-order)	XXXXXXXX _B		
001FF5 _H		Detection address setting register 1 (high-order)	XXXXXXXX _B		
003900 _H	TMR0/ TMRLR0	16-bit timer register 0/16-bit reload register	XXXXXXXX _B	16-bit reload timer 0	R,W
003901 _H			XXXXXXXX _B		

(Continued)

MB90455 Series

(Continued)

Address	Register abbreviation	Register name	Reset value	Peripheral function name	Read/Write
003902 _H	TMR1/ TMRLR1	16-bit timer register 1/16-bit reload register	XXXXXXXX _B	16-bit reload timer 1	R,W
003903 _H			XXXXXXXX _B		
003904 _H to 00390F _H	(Reserved area) *				
003910 _H	PRL0	PPG0 reload register L	XXXXXXXX _B	8/16-bit PPG timer	R/W
003911 _H	PRLH0	PPG0 reload register H	XXXXXXXX _B		R/W
003912 _H	PRL1	PPG1 reload register L	XXXXXXXX _B		R/W
003913 _H	PRLH1	PPG1 reload register H	XXXXXXXX _B		R/W
003914 _H	PRL2	PPG2 reload register L	XXXXXXXX _B		R/W
003915 _H	PRLH2	PPG2 reload register H	XXXXXXXX _B		R/W
003916 _H	PRL3	PPG3 reload register L	XXXXXXXX _B		R/W
003917 _H	PRLH3	PPG3 reload register H	XXXXXXXX _B		R/W
003918 _H to 003BFF _H	(Reserved area) *				
003C00 _H to 003C0F _H	RAM (General purpose RAM)				
003C10 _H to 003FFF _H	(Reserved area) *				

Reset values :

0 : Reset value of this bit is "0."

1 : Reset value of this bit is "1."

X : Reset value of this bit is undefined.

* : "Reserved area" should not be written anything. Result of reading from "Reserved area" is undefined.

■ INTERRUPT SOURCES, INTERRUPT VECTORS, AND INTERRUPT CONTROL REGISTERS

Interrupt source	E ² OS readiness	Interrupt vector		Interrupt control register		Priority*3	
		Number	Address	ICR	Address		
Reset	×	#08	08 _H	FFFFDC _H	—	—	High ↑
INT 9 instruction	×	#09	09 _H	FFFFD8 _H	—	—	
Exceptional treatment	×	#10	0A _H	FFFFD4 _H	—	—	
Reserved	×	#11	0B _H	FFFFD0 _H	ICR00	0000B0 _H	
Reserved	×	#12	0C _H	FFFFCC _H			
Reserved	×	#13	0D _H	FFFFC8 _H	ICR01	0000B1 _H	
Reserved	×	#14	0E _H	FFFFC4 _H			
Reserved	×	#15	0F _H	FFFFC0 _H	ICR02	0000B2 _H	
Time-base timer	×	#16	10 _H	FFFFBC _H			
16-bit reload timer 0	Δ	#17	11 _H	FFFFB8 _H	ICR03	0000B3 _H *1	
8/10-bit A/D converter	Δ	#18	12 _H	FFFFB4 _H			
16-bit free-run timer overflow	Δ	#19	13 _H	FFFFB0 _H	ICR04	0000B4 _H	
Reserved	×	#20	14 _H	FFFFAC _H			
Reserved	×	#21	15 _H	FFFFA8 _H	ICR05	0000B5 _H	
PPG timer ch0, ch1 underflow	×	#22	16 _H	FFFFA4 _H			
Input capture 0-input	Δ	#23	17 _H	FFFFA0 _H	ICR06	0000B6 _H *1	
External interrupt (INT4/INT5)	Δ	#24	18 _H	FFFF9C _H			
Input capture 1-input	Δ	#25	19 _H	FFFF98 _H	ICR07	0000B7 _H *2	
PPG timer ch2, ch3 underflow	×	#26	1A _H	FFFF94 _H			
External interrupt (INT6/INT7)	Δ	#27	1B _H	FFFF90 _H	ICR08	0000B8 _H *1	
Clock timer	Δ	#28	1C _H	FFFF8C _H			
Reserved	×	#29	1D _H	FFFF88 _H	ICR09	0000B9 _H	
Input capture 2-input Input capture 3-input	×	#30	1E _H	FFFF84 _H			
Reserved	×	#31	1F _H	FFFF80 _H	ICR10	0000BA _H	
Reserved	×	#32	20 _H	FFFF7C _H			
Reserved	×	#33	21 _H	FFFF78 _H	ICR11	0000BB _H	
Reserved	×	#34	22 _H	FFFF74 _H			
Reserved	×	#35	23 _H	FFFF70 _H	ICR12	0000BC _H	↓ Low
16-bit reload timer 1	○	#36	24 _H	FFFF6C _H			

(Continued)

MB90455 Series

(Continued)

Cause of interrupt	EI ² OS readiness	Interrupt vector			Interrupt control register		Priority* ³
		Number		Address	ICR	Address	
UART1 reception completed	○	#37	25 _H	FFFF68 _H	ICR13	0000BD _H * ¹	High ↑
UART1 transmission completed	Δ	#38	26 _H	FFFF64 _H			
Reserved	×	#39	27 _H	FFFF60 _H	ICR14	0000BE _H	
Reserved	×	#40	28 _H	FFFF5C _H			
Flash memory	×	#41	29 _H	FFFF58 _H	ICR15	0000BF _H	↓ Low
Delay interrupt generation module	×	#42	2A _H	FFFF54 _H			

○ : Available

×

◎ : Available EI²OS function is provided.

Δ : Available when a cause of interrupt sharing a same ICR is not used.

- *1:
- Peripheral functions sharing an ICR register have the same interrupt level.
 - If peripheral functions share an ICR register, only one function is available when using expanded intelligent I/O service (EI²OS) .
 - If peripheral functions share an ICR register, a function using expanded intelligent I/O service (EI²OS) does not allow interrupt by another function.

*2: Input capture 1 is ready only for EI²OS, and PPG is not ready for EI²OS. Disable PPG interrupt when using EI²OS with Input capture 1.

*3: Priority when two or more interrupts of a same level occur simultaneously.

■ PERIPHERAL RESOURCES

1. I/O Ports

The I/O ports are used as general-purpose input/output ports (parallel I/O ports). The MB90455 series model is provided with 5 ports (34 inputs). The ports function as input/output pins for peripheral functions also.

• I/O port functions

An I/O port, using port data register (PDR), outputs the output data to I/O pin and input a signal input to I/O port. The port direction register (DDR) specifies direction of input/output of I/O pins on a bit-by-bit basis.

The following summarizes functions of the ports and sharing peripheral functions :

- Port 1 : General-purpose input/output port, used also for PPG timer output and input capture inputs.
- Port 2 : General-purpose input/output port, used also for reload timer input/output and external interrupt input.
- Port 3 : General-purpose input/output port, used also for A/D converter activation trigger pin.
- Port 4 : General-purpose input/output port, used also for UART input/output.
- Port 5 : General-purpose input/output port, used also analog input pin.

• Port 1 pins block diagram (single-chip mode)

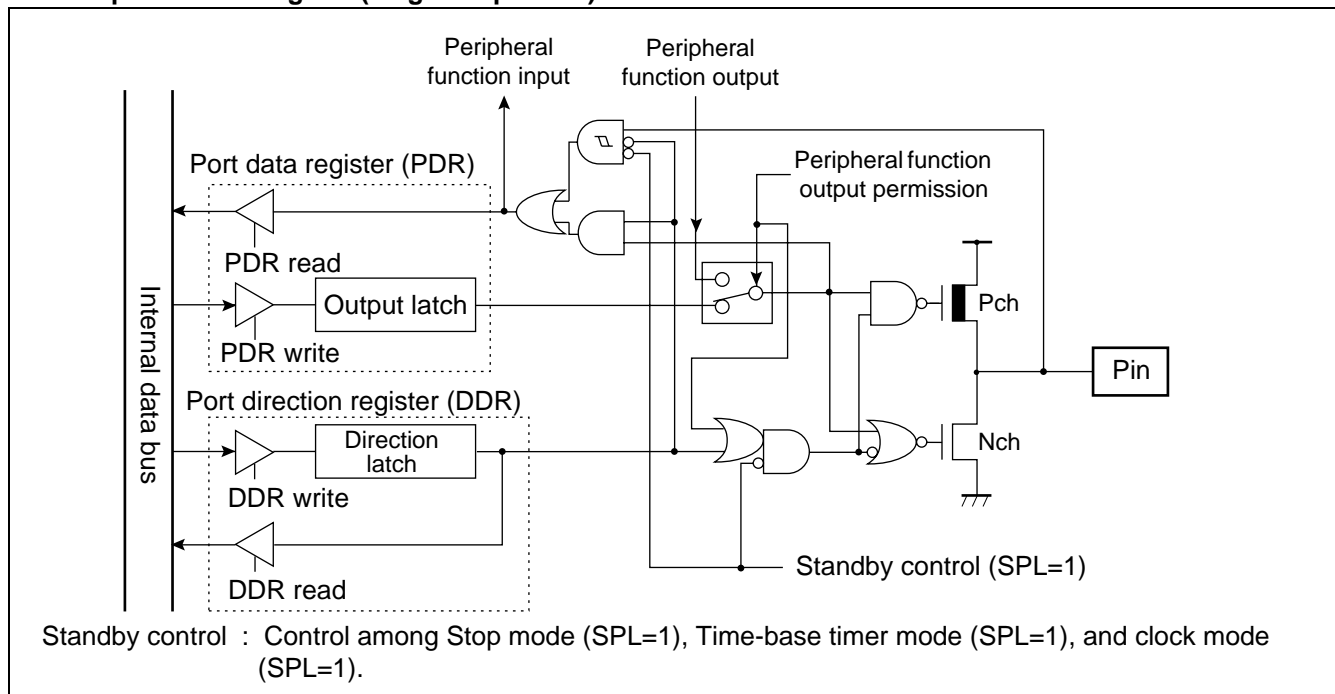

• Port 1 registers (single-chip mode)

- Port 1 registers include port 1 data register (PDR1) and port 1 direction register (DDR1).
- The bits configuring the register correspond to port 1 pins on a one-to-one basis.

Relation between port 1 registers and pins

Port name	Bits of register and corresponding pins								
	PDR1, DDR1	bit7	bit6	bit5	bit4	bit3	bit2	bit1	bit0
Port 1	Corresponding pins	P17	P16	P15	P14	P13	P12	P11	P10

MB90455 Series

• Port 2 pins block diagram (general-purpose input/output port)

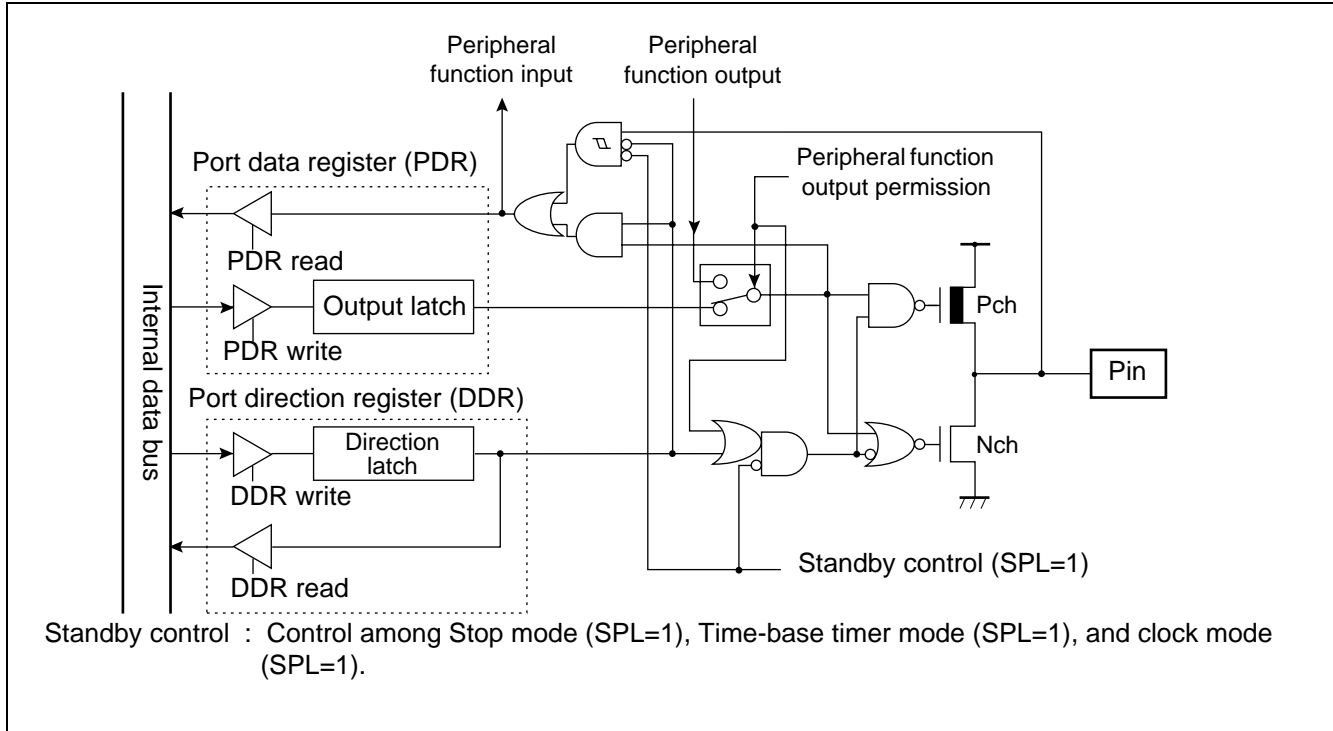

• Port 2 registers

- Port 2 registers include port 2 data register (PDR2) and port 2 direction register (DDR2).
- The bits configuring the register correspond to port 2 pins on a one-to-one basis.

Relation between port 2 registers and pins

Port name	Bits of register and corresponding pins								
	PDR2,DDR2	bit7	bit6	bit5	bit4	bit3	bit2	bit1	bit0
Port 2	Corresponding pins	P27	P26	P25	P24	P23	P22	P21	P20

• Port 3 pins block diagram (general-purpose input/output port)

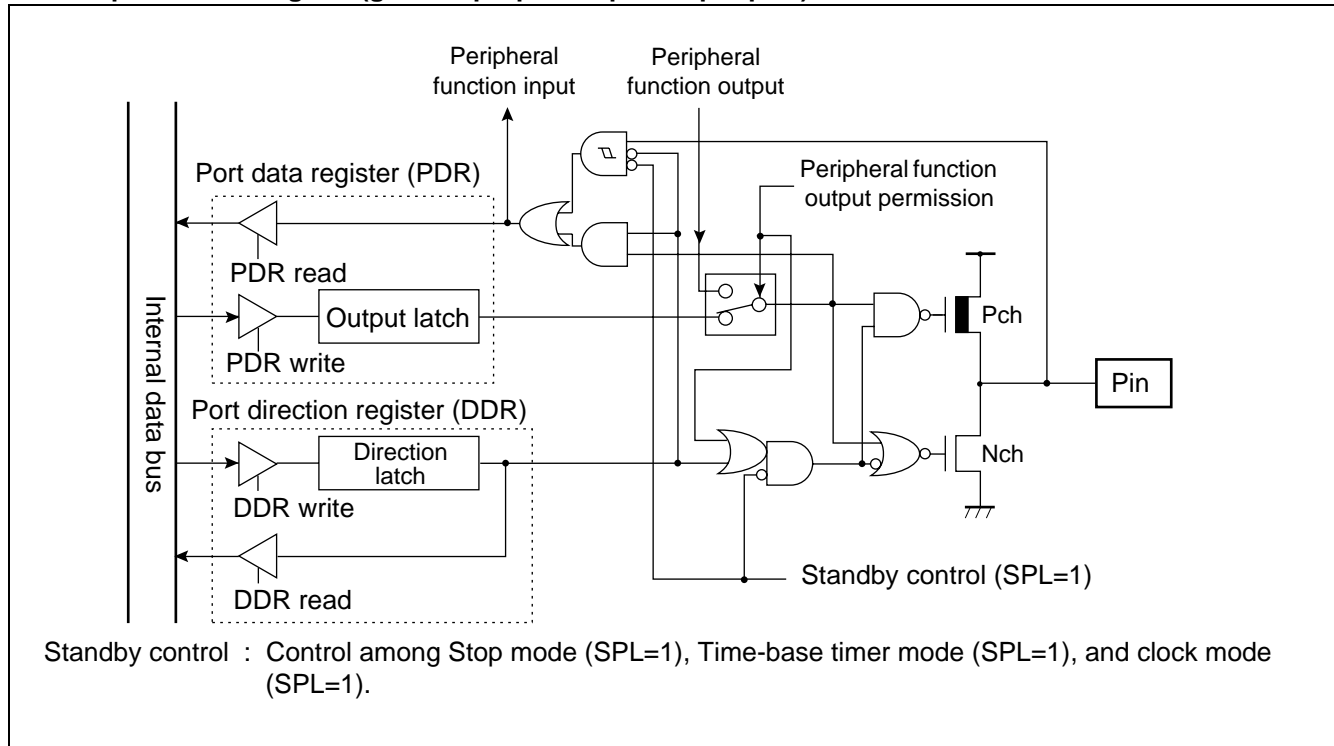

• Port 3 registers

- Port 3 registers include port 3 data register (PDR3) and port 3 direction register (DDR3).
- The bits configuring the register correspond to port 3 pins on a one-to-one basis.

Relation between port 3 registers and pins

Port name	Bits of register and corresponding pins								
	PDR3, DDR3	bit7	bit6	bit5	bit4	bit3	bit2	bit1	bit0
Port 3	Corresponding pins	P37	P36*	P35*	—	P33	P32	P31	P30

* : P35 and P36 do not exist on MB90F455/F456/F457, and MB90455/456/457.

MB90455 Series

• Port 4 pins block diagram

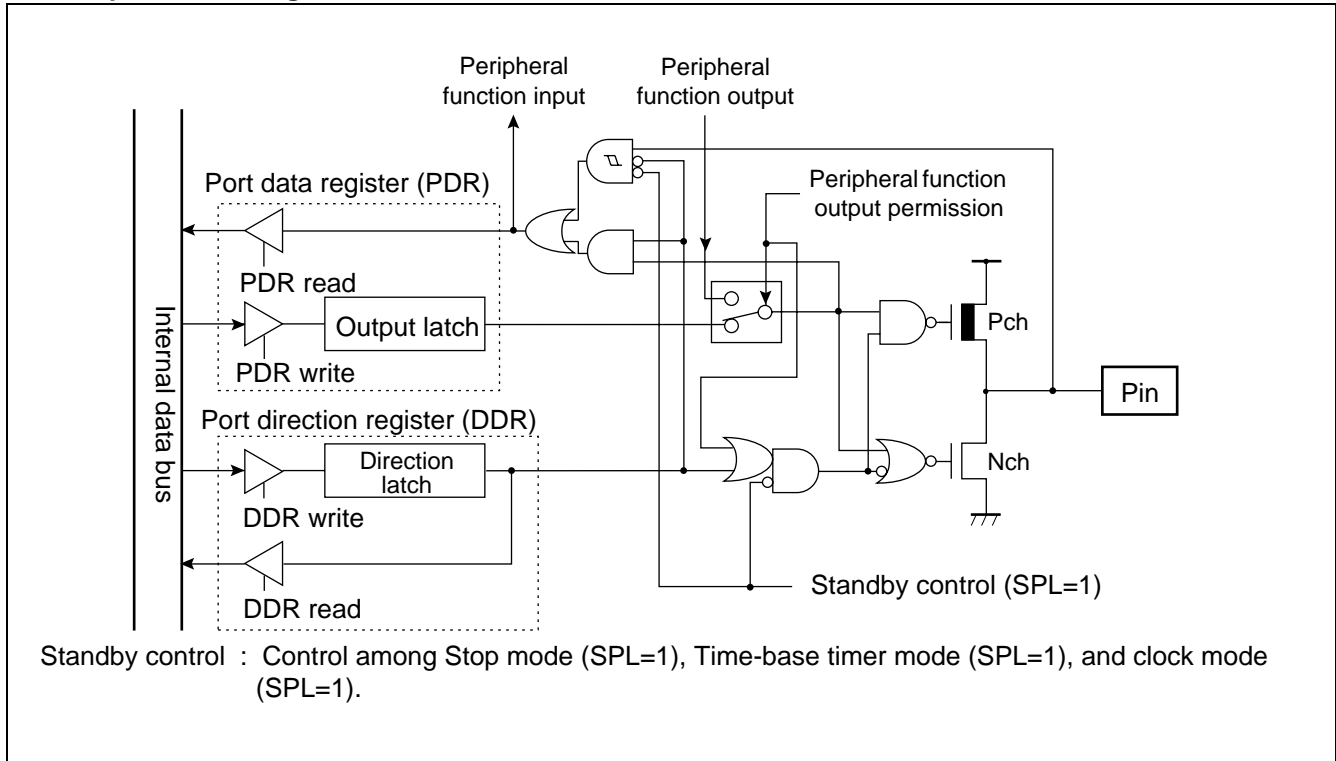

• Port 4 registers

- Port 4 registers include port 4 data register (PDR4) and port 4 direction register (DDR4).
- The bits configuring the register correspond to port 4 pins on a one-to-one basis.

Relation between port 4 registers and pins

Port name	Bits of register and corresponding pins									
Port 4	PDR4, DDR4	—	—	—	bit4	bit3	bit2	bit1	bit0	
	Corresponding pins	—	—	—	P44	P43	P42	P41	P40	

• Port 5 pins block diagram

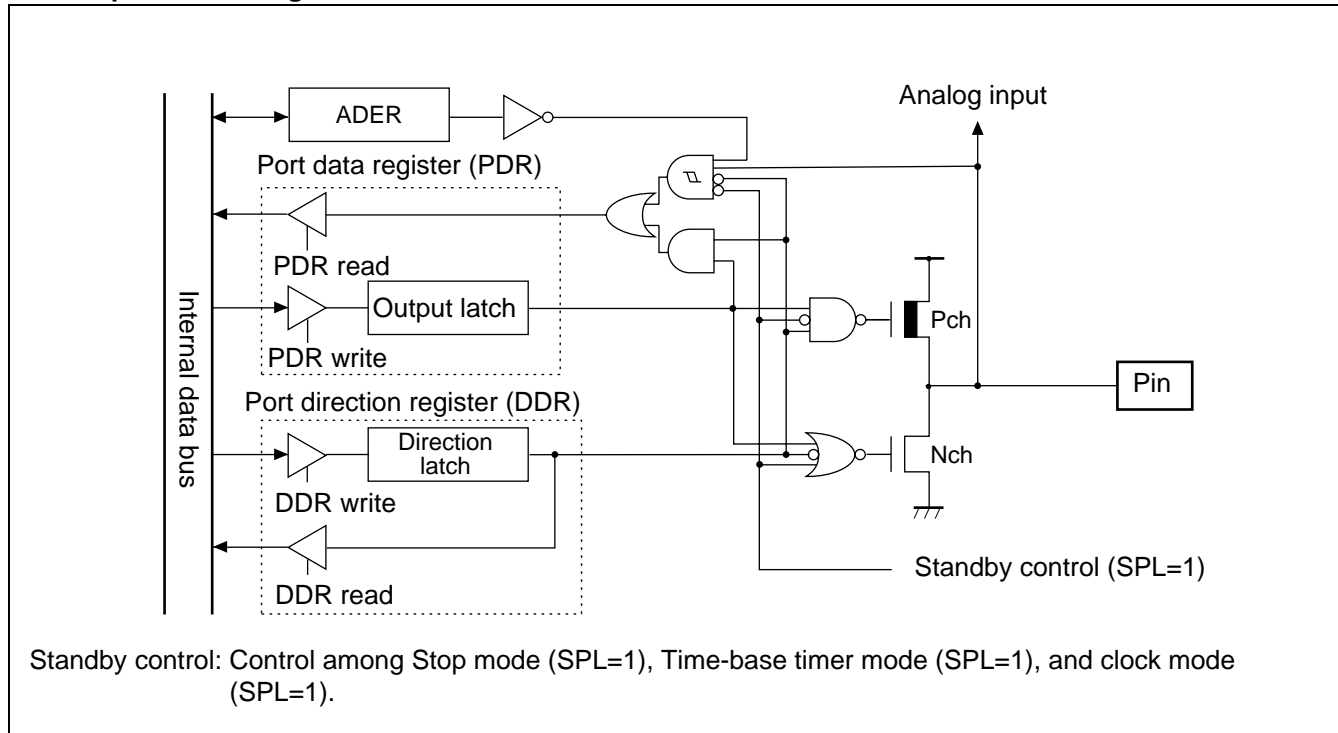

• Port 5 registers

- Port 5 registers include port 5 data register (PDR5), port 5 direction register (DDR5), and analog input permission register (ADER).
- Analog input permission register (ADER) allows or disallows input of analog signal to the analog input pin.
- The bits configuring the register correspond to port 5 pins on a one-to-one basis.

Relation between port 5 registers and pins

Port name	Bits of register and corresponding pins								
Port 5	PDR5, DDR5	bit7	bit6	bit5	bit4	bit3	bit2	bit1	bit0
	ADER	ADE7	ADE6	ADE5	ADE4	ADE3	ADE2	ADE1	ADE0
	Corresponding pins	P57	P56	P55	P54	P53	P52	P51	P50

MB90455 Series

2. Time-Base Timer

The time-base timer is a 18-bit free-run counter (time-base timer counter) that counts up in synchronization with the main clock (dividing main oscillation clock by 2).

- Four choices of interval time are selectable, and generation of interrupt request is allowed for each interval time.
- Provides operation clock signal to oscillation stabilizing wait timer and peripheral functions.

• Interval timer function

- When the counter of time-base timer reaches an interval time specified by interval time selection bit (TBTC:TBC1, TBC0), an overflow (carrying-over) occurs (TBTC: TBOF=1) and interrupt request is generated.
- If an interrupt by overflow is permitted (TBTC: TBIE=1), an interrupt is generated when overflow occurs (TBTC: TBOF=1).
- The following four interval time settings are selectable :

Interval time of time-base timer

Count clock	Interval time
2/HCLK (0.5 μ s)	2^{12} /HCLK (Approx. 1.0 ms)
	2^{14} /HCLK (Approx. 4.1 ms)
	2^{16} /HCLK (Approx. 16.4 ms)
	2^{19} /HCLK (Approx. 131.1 ms)

HCLK: Oscillation clock

Values in parentheses “()” are those under operation of 4-MHz oscillation clock.

• Time-base timer block diagram

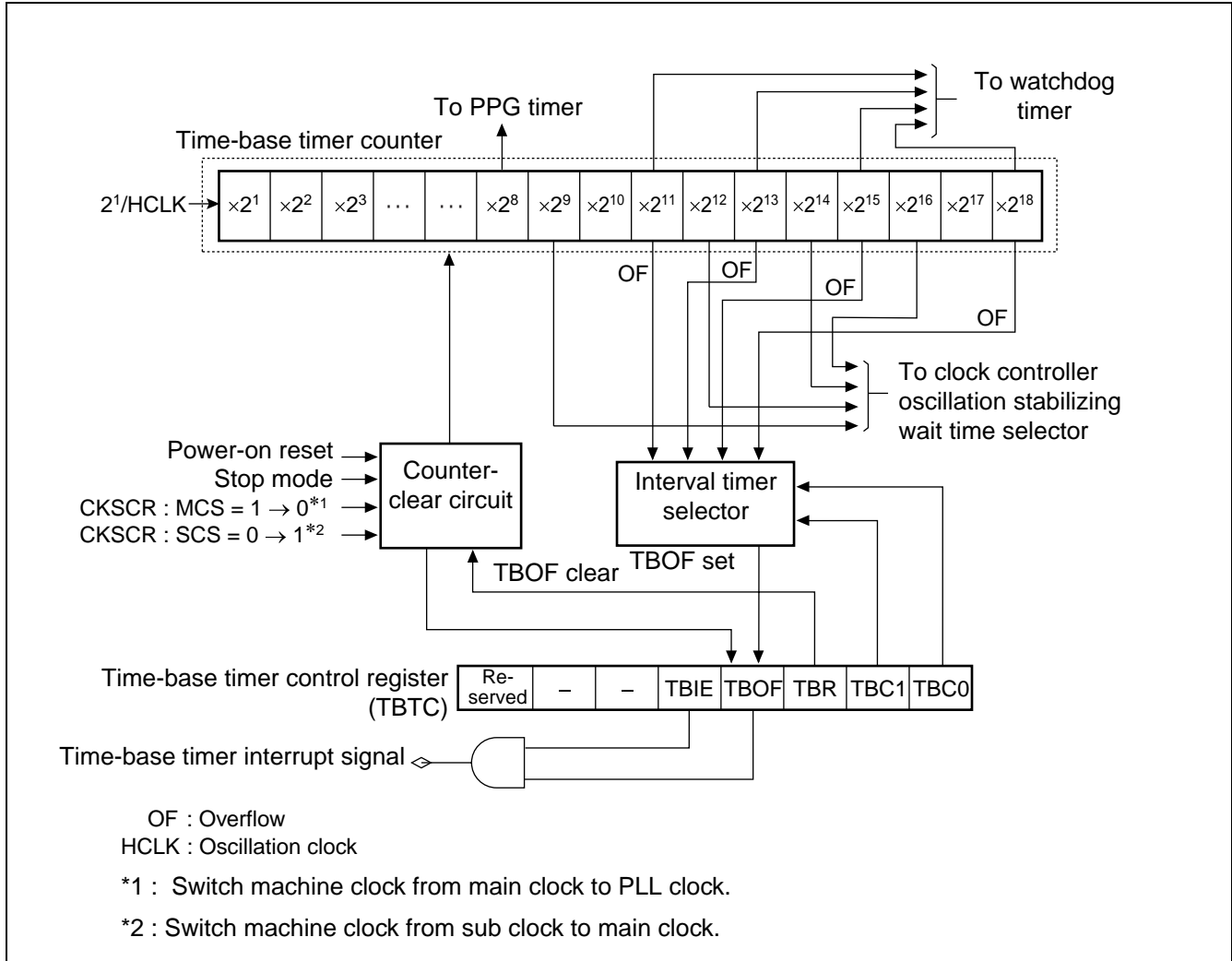

Actual interrupt request number of time-base timer is as follows:

Interrupt request number: #16 (10_H)

MB90455 Series

3. Watchdog Timer

The watchdog timer is a 2-bit counter that uses time-base timer or clock timer as count clock. If the counter is not cleared within an interval time, CPU is reset.

• Watchdog timer functions

- The watchdog timer is a timer counter that prevents runaway of a program. Once a watchdog timer is activated, the counter of watchdog timer must always be cleared within a specified time of interval. If specified interval time elapses without clearing the counter of a watchdog timer, CPU resetting occurs. This is the function of a watchdog timer.
- The interval time of a watchdog timer is determined by a clock cycle, which is input as a count clock. Watchdog resetting occurs between a minimum time and a maximum time specified.
- The output target of a clock source is specified by the watchdog clock selection bit (WTC: WDCS) in the clock timer control register.
- Interval time of a watchdog timer is specified by the time-base timer output selection bit/clock timer output selection bit (WDTC: WT1, WT0) in the watchdog timer control register.

Interval timer of watchdog timer

Min	Max	Clock cycle	Min	Max	Clock cycle
Approx. 3.58 ms	Approx. 4.61 ms	$2^{14} \pm 2^{11}$ /HCLK	Approx. 0.457 s	Approx. 0.576 s	$2^{12} \pm 2^9$ /SCLK
Approx. 14.33 ms	Approx. 18.3 ms	$2^{16} \pm 2^{13}$ /HCLK	Approx. 3.584 s	Approx. 4.608 s	$2^{15} \pm 2^{12}$ /SCLK
Approx. 57.23 ms	Approx. 73.73 ms	$2^{18} \pm 2^{15}$ /HCLK	Approx. 7.168 s	Approx. 9.216 s	$2^{16} \pm 2^{13}$ /SCLK
Approx. 458.75 ms	Approx. 589.82 ms	$2^{21} \pm 2^{18}$ /HCLK	Approx. 14.336 s	Approx. 18.432 s	$2^{17} \pm 2^{14}$ /SCLK

HCLK: Oscillation clock (4 MHz) , CSCLK: Sub clock (8.192 kHz)

- Notes:
- If the time-base timer is cleared when watchdog timer count clock is used as time base timer output (carry-over signal), watchdog reset time may become longer.
 - When using the sub clock as machine clock, be sure to specify watchdog timer clock source selection bit (WDCS) in clock timer control register (WTC) at "0," selecting output of clock timer.

• Watchdog timer block diagram

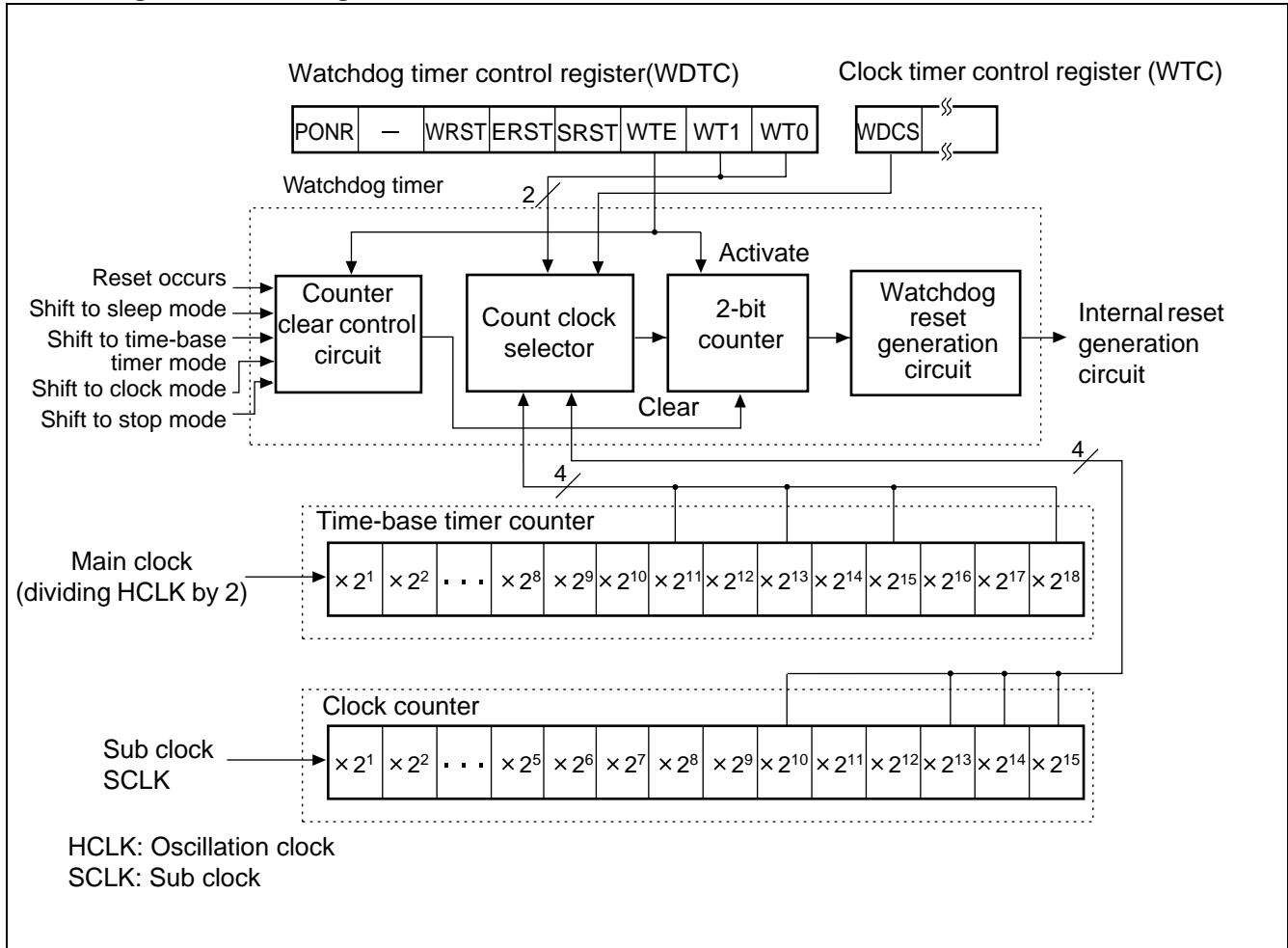

4. 16-bit Input/Output Timer

The 16-bit input/output timer is a compound module composed of 16-bit free-run timer, (1 unit) and input capture (2 units, 4 input pins). The timer, using the 16-bit free-run timer as a basis, enables measurement of clock cycle of an input signal and its pulse width.

• Configuration of 16-bit input/output timer

The 16-bit input/output timer is composed of the following modules:

- 16-bit free-run timer (1 unit)
- Input capture (2 units, 2 input pins per unit)

• Functions of 16-bit input/output timer

(1) Functions of 16-bit free-run timer

The 16-bit free-run timer is composed of 16-bit up counter, timer counter control status register, and prescaler. The 16-bit up counter increments in synchronization with dividing ratio of machine clock.

- Count clock is set among four types of machine clock dividing rates.
- Generation of interrupt is allowed by counter value overflow.
- Activation of expanded intelligent I/O service (EI²OS) is allowed by interrupt generation.
- Counter value of 16-bit free-run timer is cleared to "0000H" by either resetting or software-clearing with timer count clear bit (TCCS: CLR).
- Counter value of 16-bit free-run timer is output to input capture, which is available as base time for capture operation.

(2) Functions of input capture

The input capture, upon detecting an edge of a signal input to the input pin from external device, stores a counter value of 16-bit free-run timer at the time of detection into the input capture data register. The function includes the input capture data registers corresponding to four input pins, input capture control status register, and edge detection circuit.

- Rising edge, falling edge, and both edge are selectable for detection.
- Generating interrupt on CPU is allowed by detecting an edge of input signal.
- Expanded intelligent I/O service (EI²OS) is activated by interrupt generation.
- The four input capture input pins and input capture data registers allows monitoring of a maximum of four events.

• 16-bit input/output timer block diagram

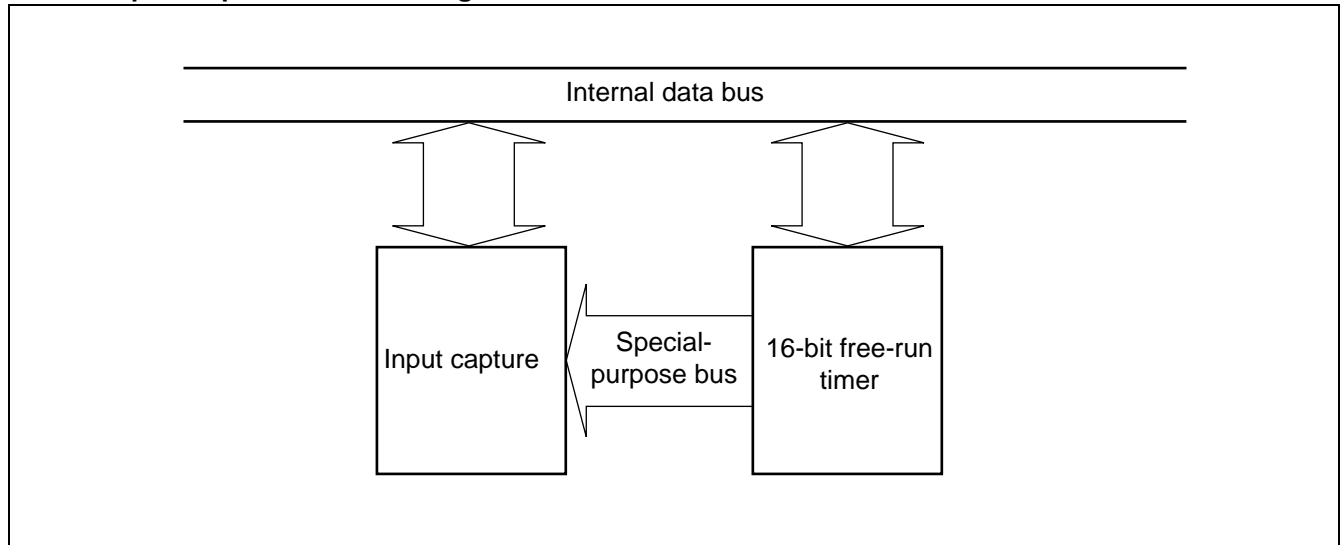

• 16-bit free-run timer

Counter value of 16-bit free-run timer is used as reference time (base time) of input capture.

• Input capture

Input capture detects rising edge, falling edge or both edges and retains a counter value of 16-bit free-run timer. Detection of edge on input signal is allowed to generate interrupt.

• 16-bit free-run timer block diagram

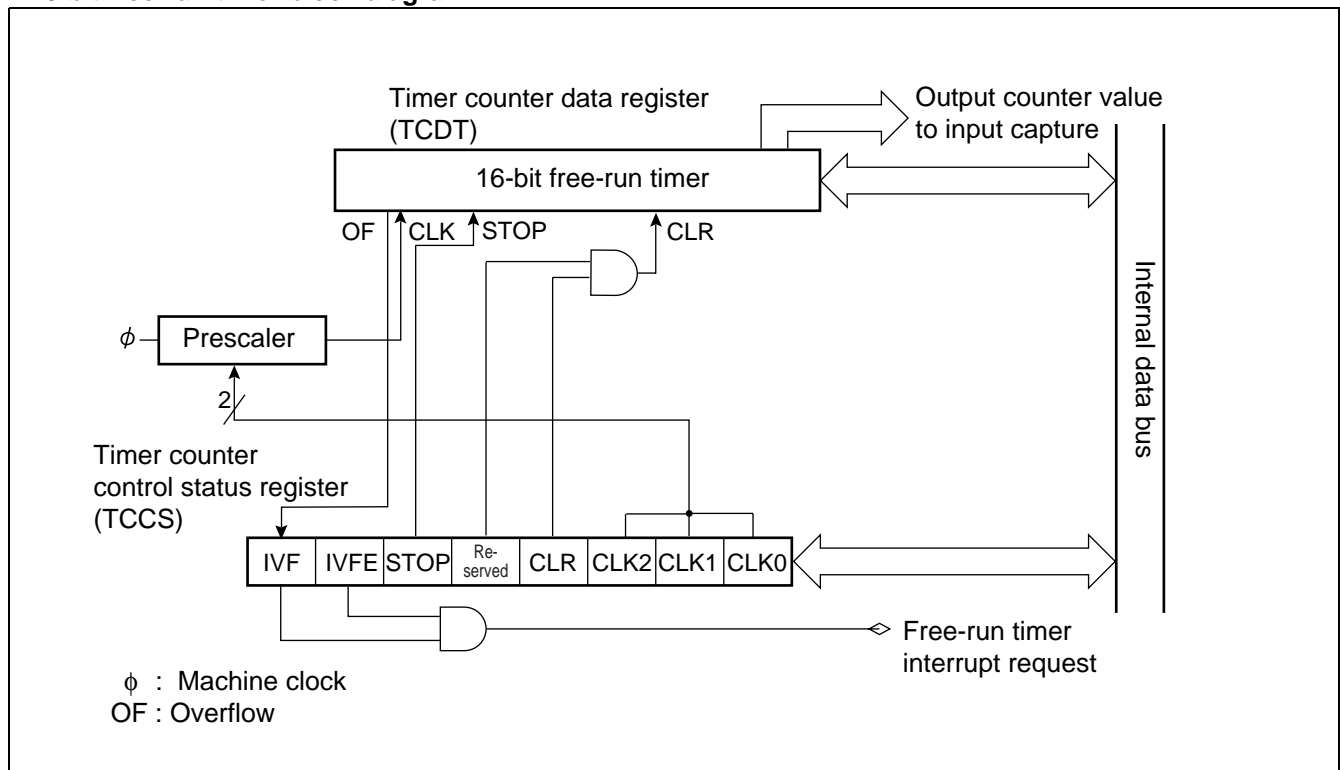

MB90455 Series

- **Detailed pin assignment on block diagram**

The 16-bit input/output timer includes a 16-bit free-run timer. Interrupt request number of the 16-bit free-run timer is as follows:

Interrupt request number: 19 (13_H)

- **Prescaler**

The prescaler divides a machine clock and provides a counter clock to the 16-bit up counter. Dividing ratio of the machine clock is specified by timer counter control status register (TCCS) among four values.

- **Timer counter data register (TCDT)**

The timer counter data register is a 16-bit up counter. A current counter value of the 16-bit free-run timer is read. Writing a value during halt of the counter allows setting an arbitrary counter value.

•Input capture block diagram

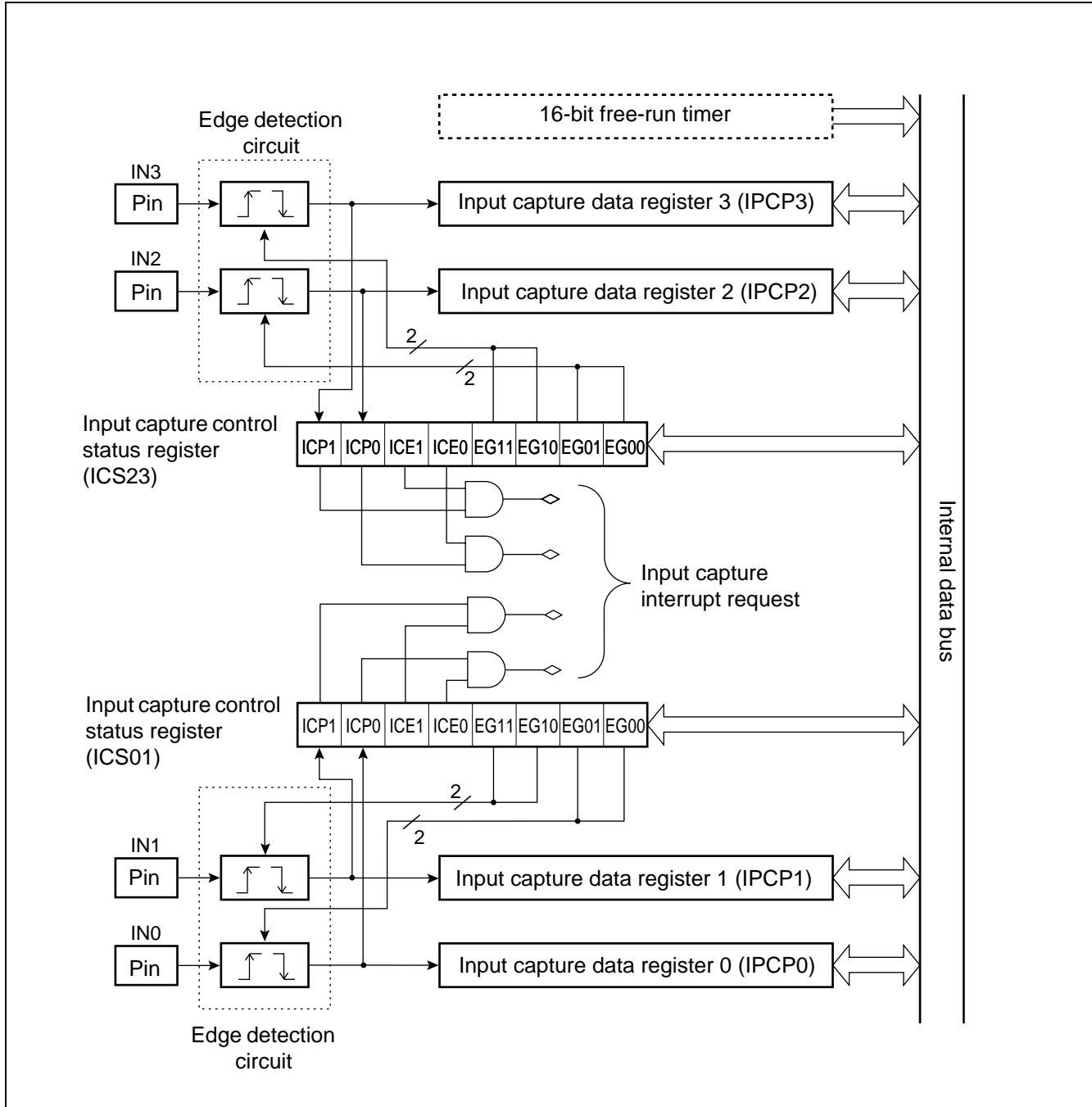

5. 16-bit Reload Timer

The 16-bit reload timer has the following functions:

- Count clock is selectable among 3 internal clocks and external event clock.
- Activation trigger is selectable between software trigger and external trigger.
- Generation of CPU interrupt is allowed upon occurrence of underflow on 16-bit timer register. Available as an interval timer using the interrupt function.
- When underflow of 16-bit timer register (TMR) occurs, one of two reload modes is selectable between one-shot mode that halts counting operation of TMR, and reload mode that reloads 16-bit reload register value to TMR, continuing TMR counting operation.
- The 16-bit reload timer is ready for expanded intelligent I/O service (EI²OS).
- MB90455 series device has 2 channels of built-in 16-bit reload timer.

• Operation mode of 16-bit reload timer

Count clock	Activation trigger	Operation upon underflow
Internal clock mode	Software trigger, external trigger	One-shot mode, reload mode
Event count mode	Software trigger	One-shot mode, reload mode

• Internal clock mode

- The 16-bit reload timer is set to internal clock mode, by setting count clock selection bit (TMCSR: CSL1, CSL0) to "00_B", "01_B", "10_B".
- In the internal clock mode, the counter decrements in synchronization with the internal clock.
- Three types of count clock cycles are selectable by count clock selection bit (TMCSR: CSL1, CSL0) in timer control status register.
- Edge detection of software trigger or external trigger is specified as an activation trigger.

• 16-bit reload timer block diagram

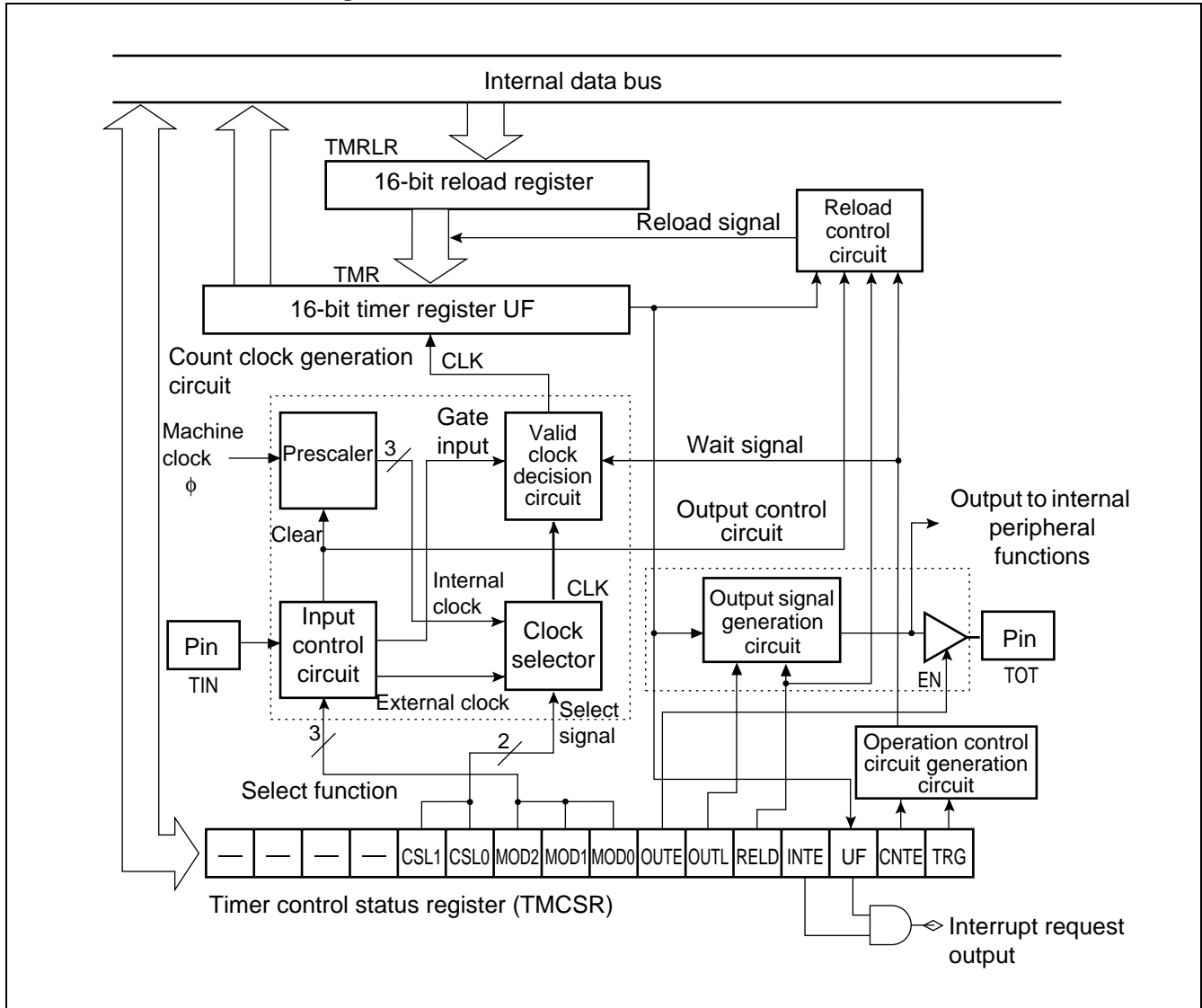

MB90455 Series

6. Clock Timer Outline

The clock timer is a 15-bit free-run counter that increments in synchronization with sub clock.

- Interval time is selectable among 7 choices, and generation of interrupt request is allowed for each interval.
- Provides operation clock to the subclock oscillation stabilizing wait timer and watchdog timer.
- Always uses subclock as a count clock regardless of settings of clock selection register (CKSCR).

• Interval timer function

- In the clock timer, a bit corresponding to the interval time overflows (carry-over) when an interval time, which is specified by interval time selection bit, is reached. Then overflow flag bit is set (WTC: WTOF=1).
- If an interrupt by overflow is permitted (WTC: WTIE=1), an interrupt request is generated upon setting an overflow flag bit.
- Interval time of clock timer is selectable among the following seven choices :

• Interval time of clock timer

Sub clock cycle	Interval time
SCLK (122 μ s)	2^8 /SCLK (31.25 ms)
	2^9 /SCLK (62.5 ms)
	2^{10} /SCLK (125 ms)
	2^{11} /SCLK (250 ms)
	2^{12} /SCLK (500 ms)
	2^{13} /SCLK (1.0 s)
	2^{14} /SCLK (2.0 s)

SCLK: Sub clock frequency

Values in parentheses “()” are calculation when operating with 8.192 kHz clock.

• Clock timer block diagram

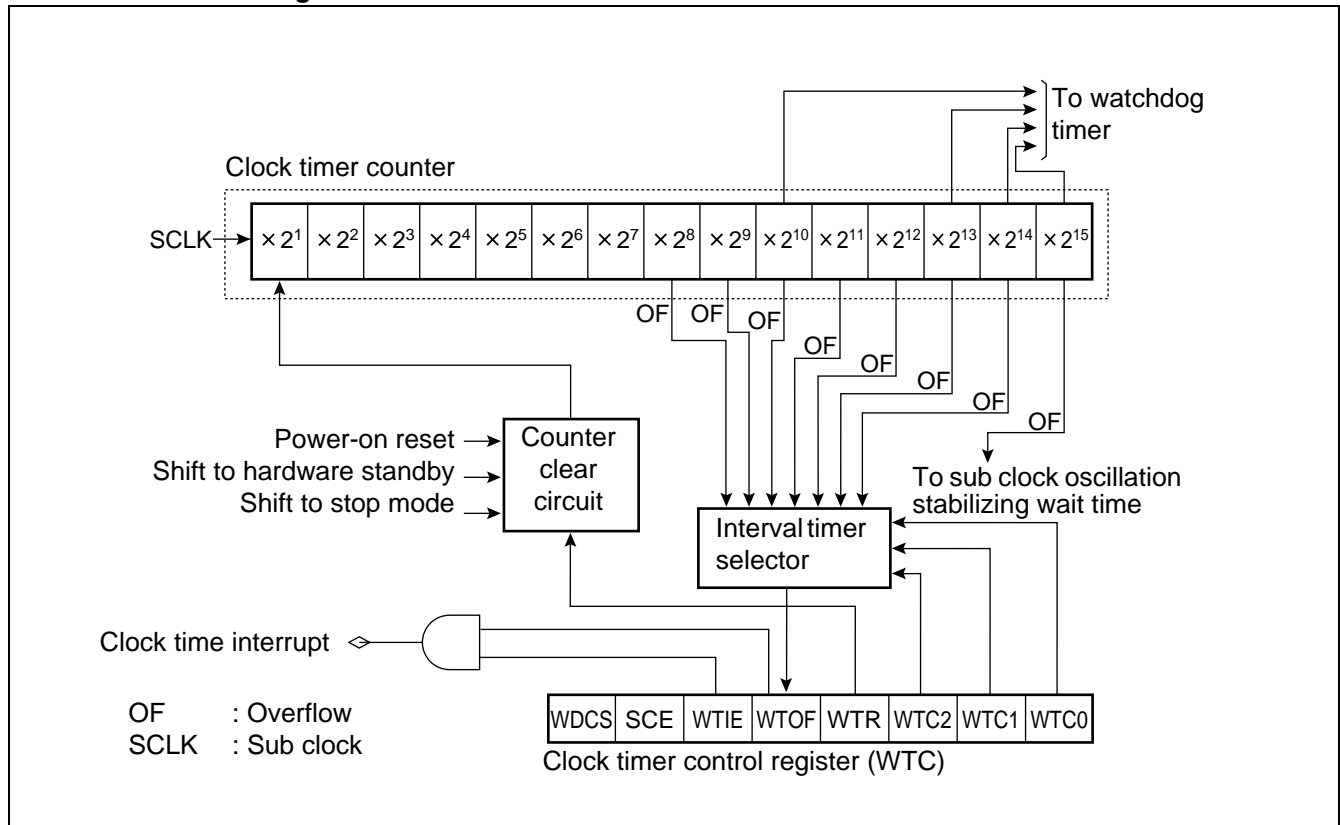

Actual interrupt request number of clock timer is as follows :

Interrupt request number : #28 (1C_H)

• Clock timer counter

A 15-bit up counter that uses sub clock (SCLK) as a count clock.

• Counter clear circuit

A circuit that clears the clock timer counter.

7. 8/16-bit PPG Timer Outline

The 8/16-bit PPG timer is a 2-channel reload timer module (PPG0 and PPG1) that allows outputting pulses of arbitrary cycle and duty cycle. Combination of the two channels allows selection among the following operations:

- 8-bit PPG output 2-channel independent operation mode
- 16-bit PPG output operation mode
- 8-bit and 8-bit PPG output operation mode

MB90455 series device has two 8/16-bit built-in PPG timers. This section describes functions of PPG0/1. PPG2/3 have the same functions as those of PPG0/1.

• Functions of 8/16-bit PPG timer

The 8/16-bit PPG timer is composed of four 8-bit reload register (PRLH0/PRL0, PRLH1/PRL1) and two PPG down counters (PCNT0, PCNT1).

- Widths of “H” and “L” in output pulse are specifiable independently. Cycle and duty factor of output pulse is specifiable arbitrarily.
- Count clock is selectable among 6 internal clocks.
- The timer is usable as an interval timer, by generating interrupt requests for each interval.
- The time is usable as a D/A converter, with an external circuit.

• 8/16-bit PPG timer0 block diagram

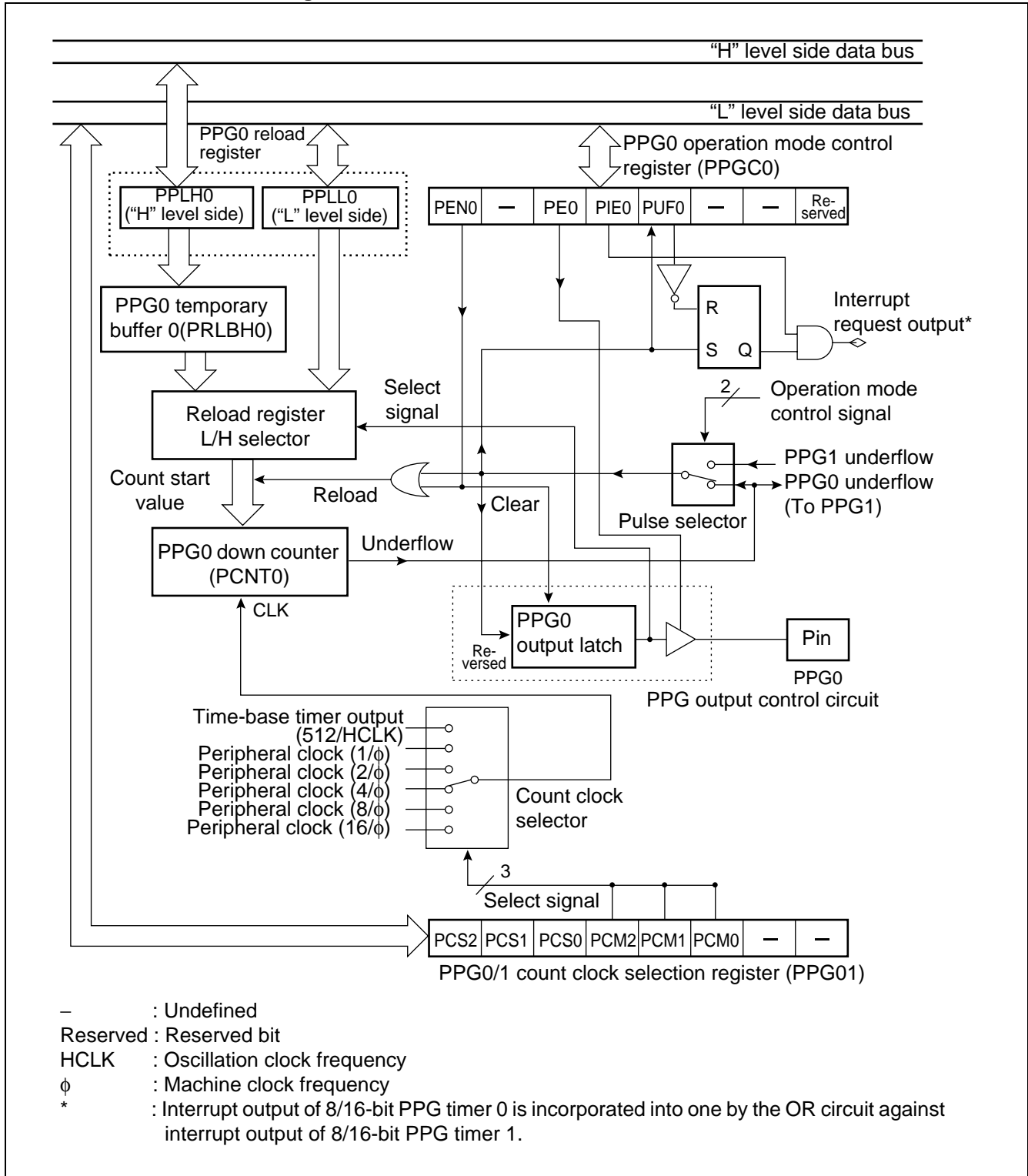

MB90455 Series

• 8/16-bit PPG timer 1 block diagram

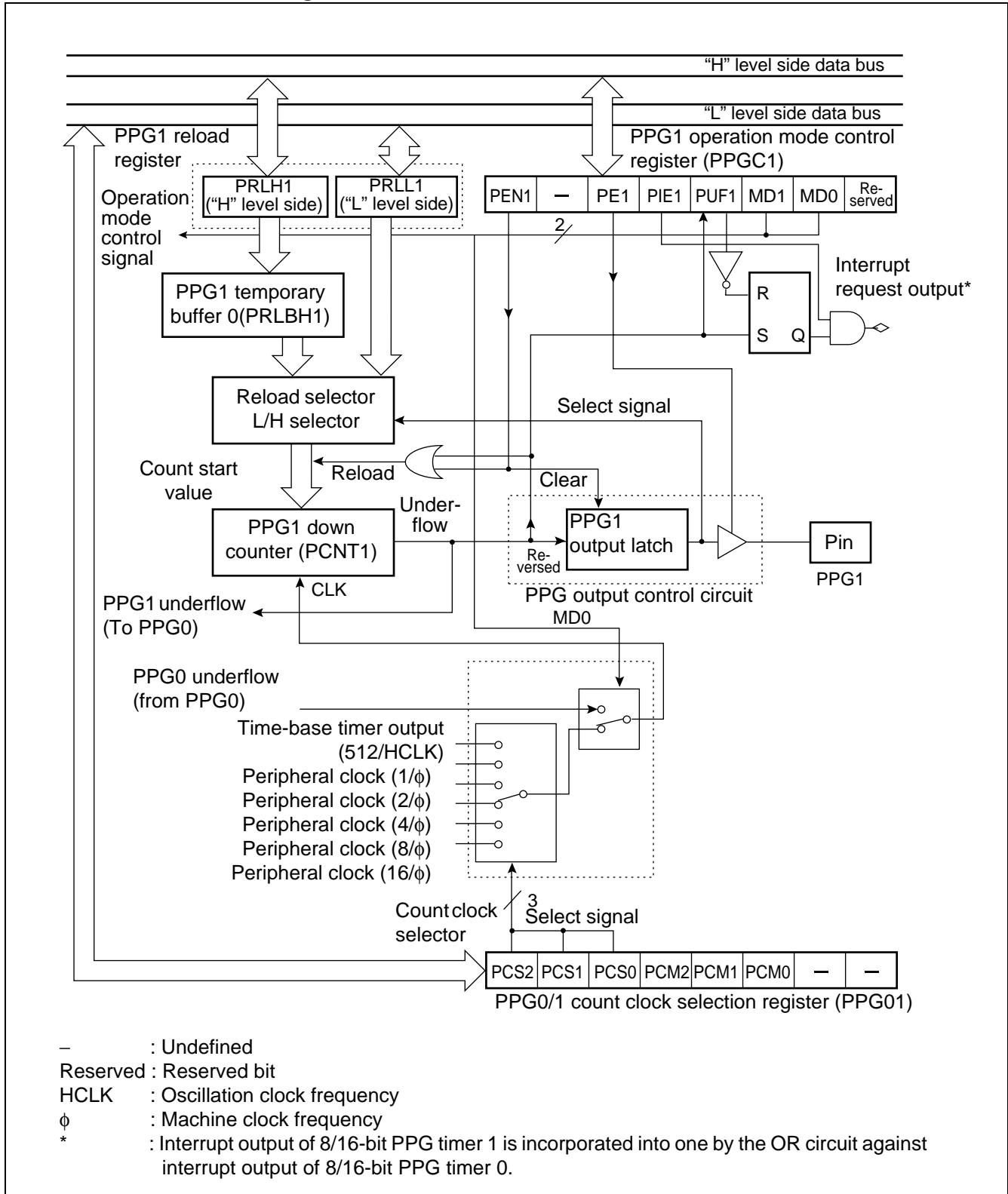

8. Delay Interrupt Generation Module Outline

The delay interrupt generation module is a module that generates interrupts for switching tasks. Generation of a hardware interrupt request is performed by software.

- **Delay interrupt generation module outline**

Using the delay interrupt generation module, hardware interrupt request is generated and released by software.

Delay interrupt generation module outline

	Function and control
Cause of interrupt	Set "1" in R0 bit of delay interrupt request generation/release register (DIRR: R0=1), generating an interrupt request. Set "0" in R0 bit of delay interrupt request generation/release register (DIRR: R0=0), releasing an interrupt request.
Interrupt number	#42 (2AH)
Interrupt control	No setting of permission register is provided.
Interrupt flag	Retained in DIRR: R0 bit
EI ² OS	Not ready for expanded intelligent I/O service.

- **Delay interrupt generation module block diagram**

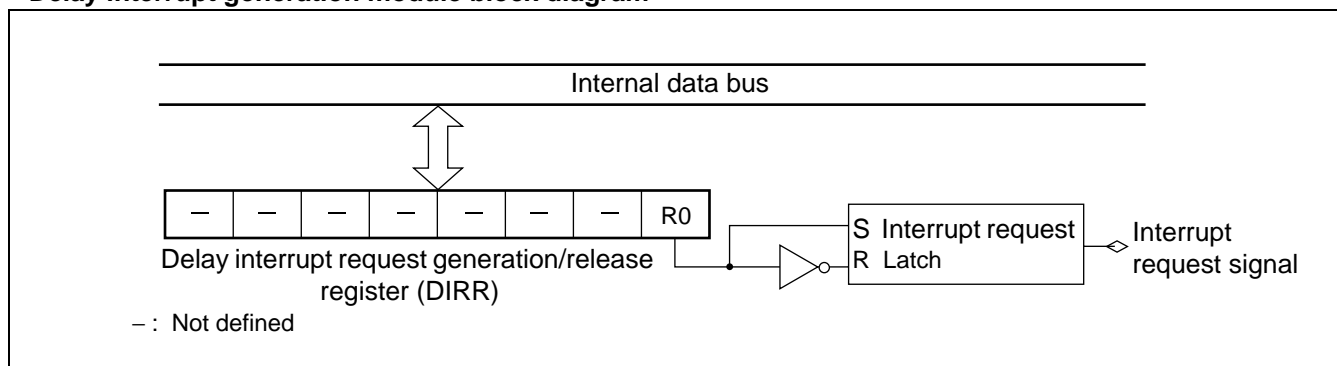

- **Interrupt request latch**

A latch that retains settings on delay interrupt request generation/release register (generation or release of delay interrupt request).

- **Delay interrupt request generation/release register (DIRR)**

Generates or releases delay interrupt request.

- **Interrupt number.**

An interrupt number used in delay interrupt generation module is as follows:

Interrupt number: #42 (2AH)

MB90455 Series

9. DTP/External Interrupt Outline

DTP/external interrupt transfers an interrupt request generated by an external peripheral device or a data transmission request to CPU, generating external interrupt request and activating expanded intelligent I/O service.

• DTP/external interrupt function

An interrupt request input from external peripheral device to external input pins (INT7 to INT4), just as interrupt request of peripheral device, generates an interrupt request. The interrupt request generates an external interrupt and activates expanded intelligent I/O service (EI²OS).

If the expanded intelligent I/O service (EI²OS) has been disabled by interrupt control register (ICR: ISE=0), external interrupt function is enabled and branches to interrupt processing.

If the EI²OS has been enabled, (ICR: ISE=1), DTP function is enabled and automatic data transmission is performed by EI²OS. After performing specified number of data transmission processes, the process branches to interrupt processing.

DTP/external interrupt

	External interrupt	DTP function
Input pin	4 pins (INT4 to INT7)	
Interrupt cause	Specify for each pin with detection level setting register (ELVR).	
	Input of "H" level/"L" level/rising edge/falling edge.	Input of "H" level/ "L" level
Interrupt number	#24 (18 _H) , #27 (1B _H)	
Interrupt control	Enabling or disabling output of interrupt request, using DTP/external interrupt permission register (ENIR).	
Interrupt flag	Retaining interrupt cause with DTP/external interrupt cause register (EIRR).	
Process selection	Disable EI ² OS (ICR: ISE=0)	Enable EI ² OS (ICR: ISE=1)
Process	Branch to external interrupt process	After automatic data transmission by EI ² OS for specified number of times, branch to interrupt process.

• DTP/External interrupt block diagram

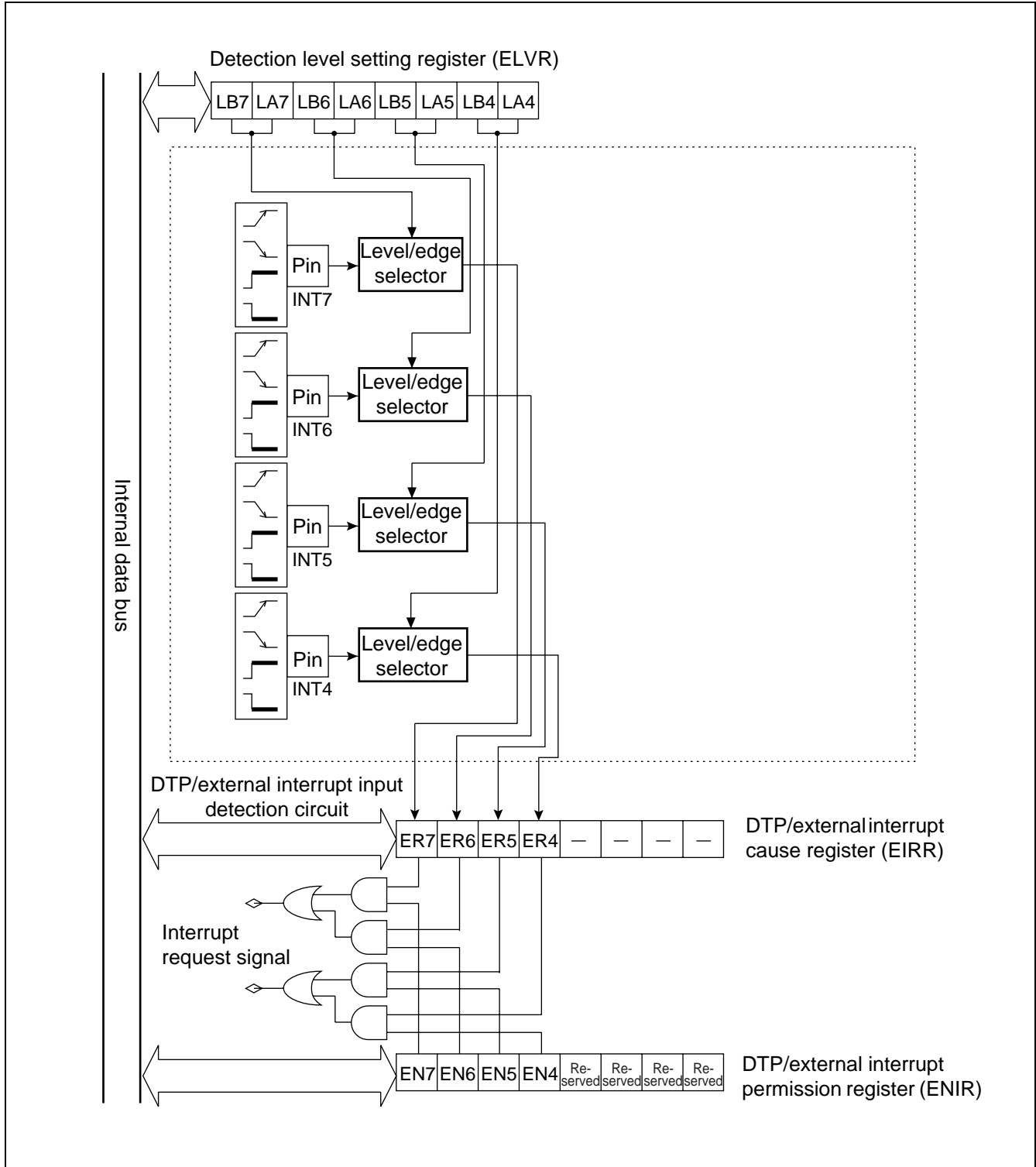

10. 8/10-bit A/D Converter

The 8/10-bit A/D converter converts an analog input voltage into 8-bit or 10-bit digital value, using the RC-type successive approximation conversion method.

- Input signal is selected among 8 channels of analog input pins.
- Activation trigger is selected among software trigger, internal timer output, and external trigger.

• Functions of 8/10-bit A/D converter

The 8/10-bit A/D converter converts an analog voltage (input voltage) input to analog input pin into an 8-bit or 10-bit digital value (A/D conversion).

The 8/10-bit A/D converter has the following functions:

- A/D conversion takes a minimum of $6.12 \mu\text{s} \times 1$ for one channel, including sampling time. (A/D conversion)
- Sampling of one channel takes a minimum of $2.0 \mu\text{s}^*$.
- RC-type successive approximation conversion method, with sample & hold circuit is used for conversion.
- Resolution of either 8 bits or 10 bits is specifiable.
- A maximum of 8 channels of analog input pins are allowed for use.
- Generation of interrupt request is allowed, by storing A/D conversion result in A/D data register.
- Activation of EI²OS is allowed upon occurrence of an interrupt request. With use of EI²OS, data loss is avoided even if A/D conversion is performed successively.
- An activation trigger is selectable among software trigger, internal timer output, and external trigger (fall edge).

*: When operating with 16-MHz machine clock

• 8/10-bit A/D converter conversion mode

Conversion mode	Description
Singular conversion mode	The A/D conversion is performed from a start channel to an end channel sequentially. Upon completion of A/D conversion on an end channel, A/D conversion function stops.
Sequential conversion mode	The A/D conversion is performed from a start channel to an end channel sequentially. Upon completion of A/D conversion on an end channel, A/D conversion function resumes from the start channel.
Pausing conversion mode	The A/D conversion is performed by pausing at each channel. Upon completion of A/D conversion on an end channel, A/D conversion and pause functions resume from the start channel.

• 8/10-bit A/D converter block diagram

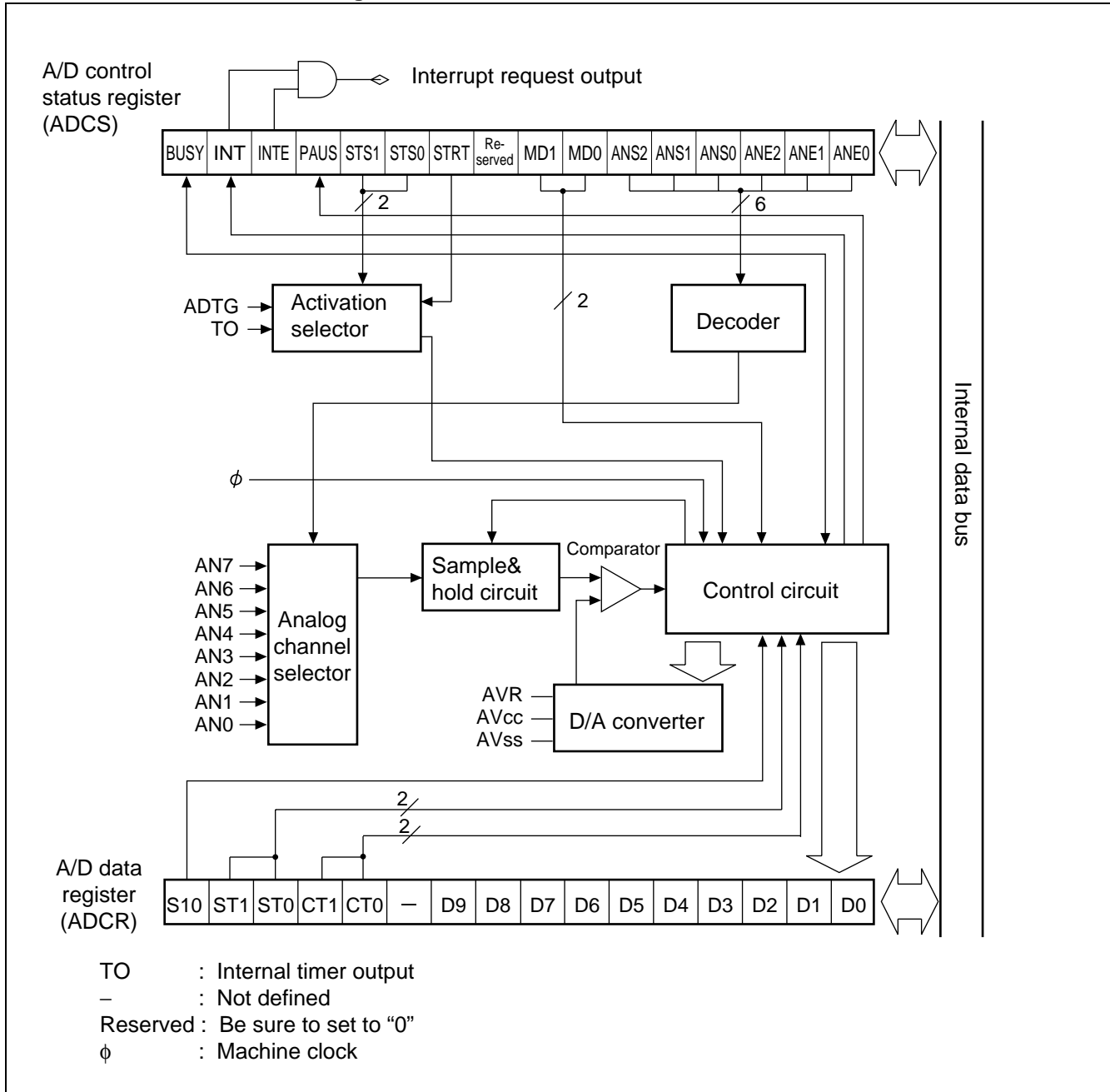

MB90455 Series

11. UART Outline

UART is a general-purpose serial data communication interface for synchronous and asynchronous communication using external devices.

- Provided with bi-directional communication function for both clock-synchronous and clock-asynchronous modes.
- Provided with master/slave communication function (multi-processor mode). (Only master side is available.)
- Interrupt request is generated upon completion of reception, completion of transmission and detection of reception error.
- Ready for expanded intelligent service, EI²OS.

UART functions

	Description
Data buffer	Full-duplex double buffer
Transmission mode	Clock synchronous (No start/stop bit, no parity bit) Clock asynchronous (start-stop synchronous)
Baud rate	Built-in special-purpose baud-rate generator. Setting is selectable among 8 values. Input of external values is allowed. Use of clock from external timer (16-bit reload timer 0) is allowed.
Data length	7 bits (only asynchronous normal mode) 8 bits
Signaling system	Non Return to Zero (NRZ) system
Reception error detection	Framing error Overrun error Parity error (not detectable in operation mode 1 (multi-processor mode))
Interrupt request	Receive interrupt (reception completed, reception error detected) Transmission interrupt (transmission completed) Ready for expanded intelligent I/O service (EI ² OS) in both transmission and reception
Master/slave communication function (asynchronous, multi-processor mode)	Communication between 1 (master) and n (slaves) are available (usable as master only).

Note : Start/stop bit is not added upon clock-synchronous transmission. Data only is transmitted.

UART operation modes

Operation mode	Data length		Synchronization	Stop bit length
	With parity	Without parity		
0 Asynchronous mode (normal mode)	7-bit or 8-bit		Asynchronous	1-bit or 2-bit *2
1 Multi processor mode	8+1*1	—	Asynchronous	
2 Synchronous mode	8	—	Synchronous	No

— : Disallowed

*1 : "+1" is an address/data selection bit used for communication control (bit 11 of SCR1 register: A/D)

*2 : Only 1 bit is detected as a stop bit on data reception.

• UART block diagram

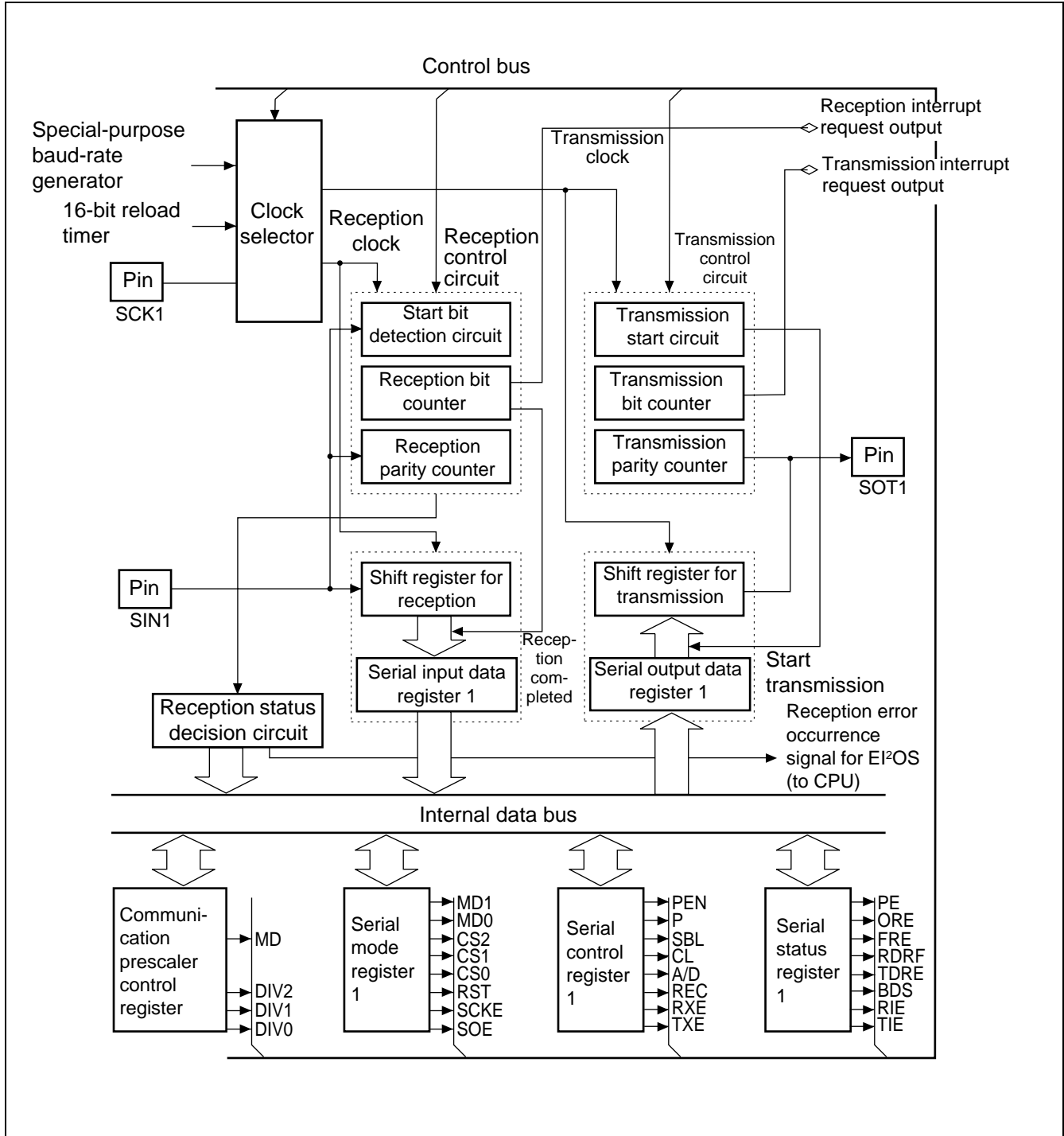

12. Address Matching Detection Function Outline

The address matching detection function checks if an address of an instruction to be processed next to a currently-processed instruction is identical with an address specified in the detection address register. If the addresses match with each other, an instruction to be processed next in program is forcibly replaced with INT9 instruction, and process branches to the interrupt process program. Using INT9 interrupt, this function is available for correcting program by batch processing.

• Address matching detection function outline

- An address of an instruction to be processed next to a currently-processed instruction of the program is always retained in an address latch via internal data bus. By the address matching detection function, the address value retained in the address latch is always compared with an address specified in detection address setting register. If the compared address values match with each other, an instruction to be processed next by CPU is forcibly replaced with INT9 instruction, and an interrupt process program is executed.
- Two detection address setting registers are provided (PADR0 and PADR1), and each register is provided with interrupt permission bit. Generation of interrupt, which is caused by address matching between the address retained in address latch and the address specified in address setting register, is permitted and prohibited on a register-by-register basis.

• Address matching detection function block diagram

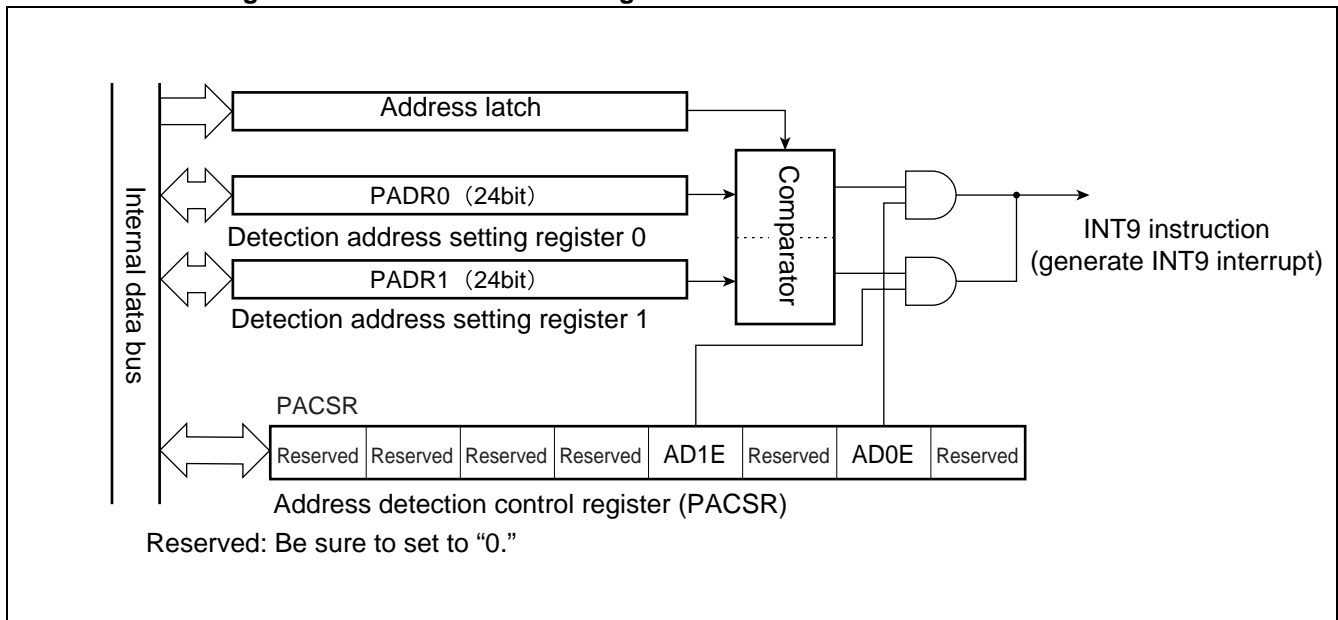

- Address latch
Retains address value output to internal data bus.
- Address detection control register (PACSR)
Specifies if interrupt is permitted or prohibited when addresses match with each other.
- Detection address setting (PADR0, PADR1)
Specifies addresses to be compared with values in address latch.

13. ROM Mirror Function Selection Module Outline

The ROM mirror function selection module sets the data in ROM assigned to FF bank so that the data is read by access to 00 bank.

• ROM mirror function selection module block diagram

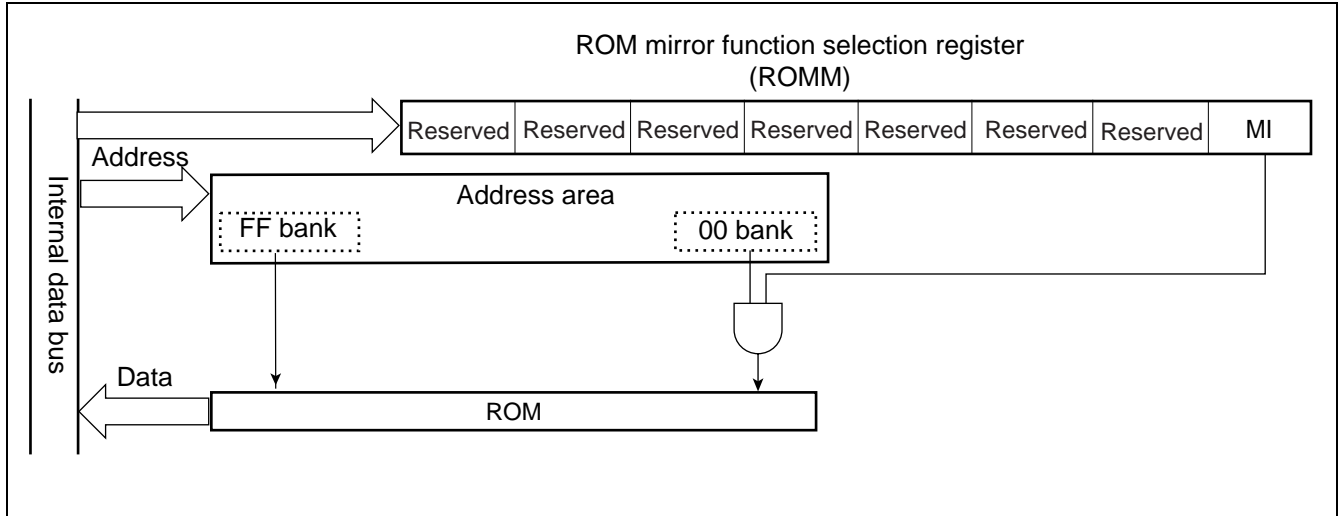

• FF bank access by ROM mirror function

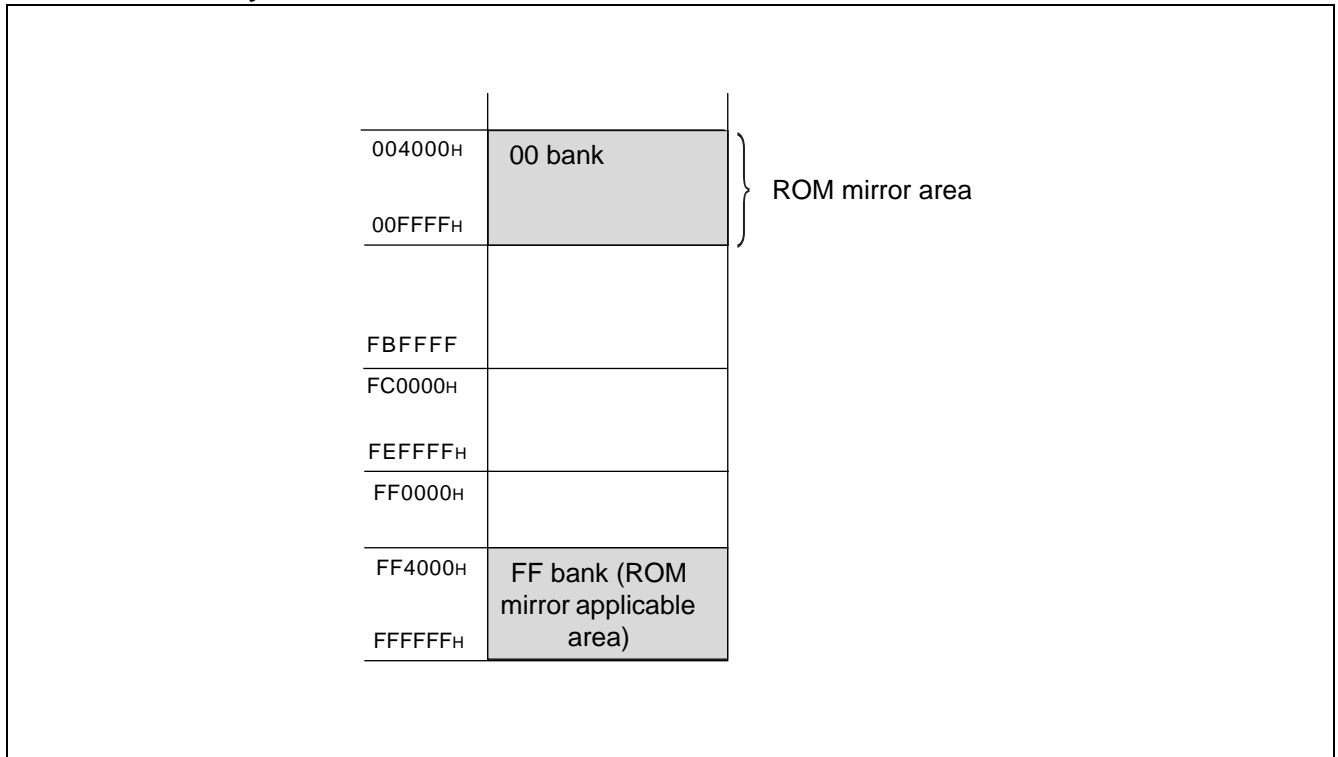

MB90455 Series

14. 192 K/256 K/512 Kbit Flash Memory Outline

The following three methods are provided for data writing and deleting on flash memory:

1. Parallel writer
2. Serial special-purpose writer
3. Writing/deleting by program execution

• 192 K/256 K/512 Kbit flash memory outline

The 192 K/256 K/512K-bit flash memory is allocated on FF_H bank of CPU memory map. Using the function of flash memory interface circuit, the memory allows read access and program access from CPU.

Writing/deleting on flash memory is performed by instruction from CPU via flash memory interface. Because rewriting is allowed on mounted memory, modifying program and data is performed efficiently.

• Features of 192 K/256 K/512 Kbit flash memory

- Dividing into many sectors
- Automatic program algorithm (Embedded Algorithm™: Similar to MBM29LV200.)
- Built-in deletion pause/deletion resume function
- Detection of completed writing/deleting by data polling and toggle bits.
- Detection of completed writing/deleting by CPU interrupt.
- Deletion is allowed on a sector-by-sector basis (sectors are combined freely).
- Number of writing/deleting operations (minimum): 10,000 times
- Sector protection
- Extended sector protection
- Temporary sector unprotection

Embedded Algorithm™ is a registered trademark of Advanced Micro Device.

Note : A function of reading manufacture code and device code is not provided. These codes are not accessible by command either.

• Flash memory writing/deleting

- Writing and reading data is not allowed simultaneously on the flash memory.
- Data writing and deleting on the flash memory is performed by the processes as follows: Make a copy of program on flash memory onto RAM. Then, execute the program copied on the RAM.

• List of registers and reset values in flash memory

Flash memory control status register (FMCS)

bit

7	6	5	4	3	2	1	0
0	0	0	X	0	0	0	0

× : Undefined

• Sector configuration of 192 K/256 K/512 Kbit flash memory

• Sector configuration of 192 Kbit to flash memory (MB90F455 (S))

Flash memory	CPU address	Writer address*
SA0 (8 Kbytes)	FFA000H	7A000H
	FFBFFFH	7BFFFH
SA1 (16 Kbytes)	FFC000H	7C000H
	FFFFFFH	7FFFFH

• Sector configuration of 256 Kbit to flash memory (MB90F456 (S))

Flash memory	CPU address	Writer address*
SA0 (8 Kbytes)	FF8000H	78000H
	FF9FFFH	79FFFH
SA1 (8 Kbytes)	FFA000H	7A000H
	FFBFFFH	7BFFFH
SA2 (16 Kbytes)	FFC000H	7C000H
	FFFFFFH	7FFFFH

• Sector configuration of 512 Kbit to flash memory (MB90F457 (S))

Flash memory	CPU address	Writer address*
SA0 (32 Kbytes)	FF0000H	70000H
	FF7FFFH	77FFFH
SA1 (8 Kbytes)	FF8000H	78000H
	FF9FFFH	79FFFH
SA2 (8 Kbytes)	FFA000H	7A000H
	FFBFFFH	7BFFFH
SA3 (16 Kbytes)	FFC000H	7C000H
	FFFFFFH	7FFFFH

*: "Writer address" is an address equivalent to CPU address, which is used when data is written on flash memory, using parallel writer. When writing/deleting data with general-purpose writer, the writer address is used for writing and deleting.

MB90455 Series

■ ELECTRIC CHARACTERISTICS

1. Absolute Maximum Rating

($V_{SS} = AV_{SS} = 0.0\text{ V}$)

Parameter	Symbol	Rating		Unit	Remarks
		Min	Max		
Power supply voltage	V_{CC}	$V_{SS} - 0.3$	$V_{SS} + 6.0$	V	
	AV_{CC}	$V_{SS} - 0.3$	$V_{SS} + 6.0$	V	$V_{CC} = AV_{CC}^{*1}$
	AVR	$V_{SS} - 0.3$	$V_{SS} + 6.0$	V	$AV_{CC} \geq AVR^{*1}$
Input voltage	V_I	$V_{SS} - 0.3$	$V_{SS} + 6.0$	V	*2
Output voltage	V_O	$V_{SS} - 0.3$	$V_{SS} + 6.0$	V	*2
Maximum clamp current	I_{CLAMP}	-2.0	+2.0	mA	*6
Total maximum clamp current	$\sum I_{CLAMP} $	—	20	mA	*6
“L” level maximum output current	I_{OL1}	—	15	mA	Normal output*3
	I_{OL2}	—	40	mA	High-current output*3
“L” level average output current	I_{OLAV1}	—	4	mA	Normal output*4
	I_{OLAV2}	—	30	mA	High-current output*4
“L” level maximum total output current	$\sum I_{OL1}$	—	125	mA	Normal output
	$\sum I_{OL2}$	—	160	mA	High-current output
“L” level average total output current	$\sum I_{OLAV1}$	—	40	mA	Normal output*5
	$\sum I_{OLAV2}$	—	40	mA	High-current output*5
“H” level maximum output current	I_{OH1}	—	-15	mA	Normal output*3
	I_{OH2}	—	-40	mA	High-current output*3
“H” level average output current	I_{OHAV1}	—	-4	mA	Normal output*4
	I_{OHAV2}	—	-30	mA	High-current output*4
“H” level maximum total output current	$\sum I_{OH1}$	—	-125	mA	Normal output
	$\sum I_{OH2}$	—	-160	mA	High-current output
“H” level average total output current	$\sum I_{OHAV1}$	—	-40	mA	Normal output*5
	$\sum I_{OHAV2}$	—	-40	mA	High-current output*5
Power consumption	P_D	—	245	mW	
Operating temperature	T_A	-40	+105	°C	
Storage temperature	T_{stg}	-55	+150	°C	

*1 : AV_{CC} and AVR should not exceed V_{CC} . Also AVR should not exceed AV_{CC} .

*2 : V_I , V_O , should not exceed $V_{CC} + 0.3V$.

*3 : A peak value of an applicable one pin is specified as a maximum output current.

*4 : An average current value of an applicable one pin within 100 ms is specified as an average output current. (Average value is found by multiplying operating current by operating rate.)

*5 : An average current value of all pins within 100 ms is specified as an average total output current. (Average value is found by multiplying operating current by operating rate.)

(Continued)

(Continued)

- *6 : • Applicable to pins: P10 to P17, P20 to P27, P30 to P33, P35*, P36*, P37, P40 to P44, P50 to P57
Note : P35 and P36 are applicable only for products of MB90F455S/F456S/F457S, MB90455S/456S/457S.
- Use within recommended operating conditions.
 - Use at DC voltage (current) .
 - The +B signal should always be applied a limiting resistance placed between the +B signal and the microcontroller.
 - The value of the limiting resistance should be set so that when the +B signal is applied the input current to the microcontroller pin does not exceed rated values, either instantaneously or for prolonged periods.
 - Note that when the microcontroller drive current is low, such as in the power saving modes, the +B input potential may pass through the protective diode and increase the potential at the V_{CC} pin, and this may affect other devices.
 - Note that if a +B signal is input when the microcontroller power supply is off (not fixed at 0 V) , the power supply is provided from the pins, so that incomplete operation may result.
 - Note that if the +B input is applied during power-on, the power supply is provided from the pins and the resulting supply voltage may not be sufficient to operate the power-on reset.
 - Care must be taken not to leave the +B input pin open.
 - Note that analog system input/output pins other than the A/D input pins (LCD drive pins, comparator input pins, etc.) cannot accept +B signal input.
 - Sample recommended circuits:

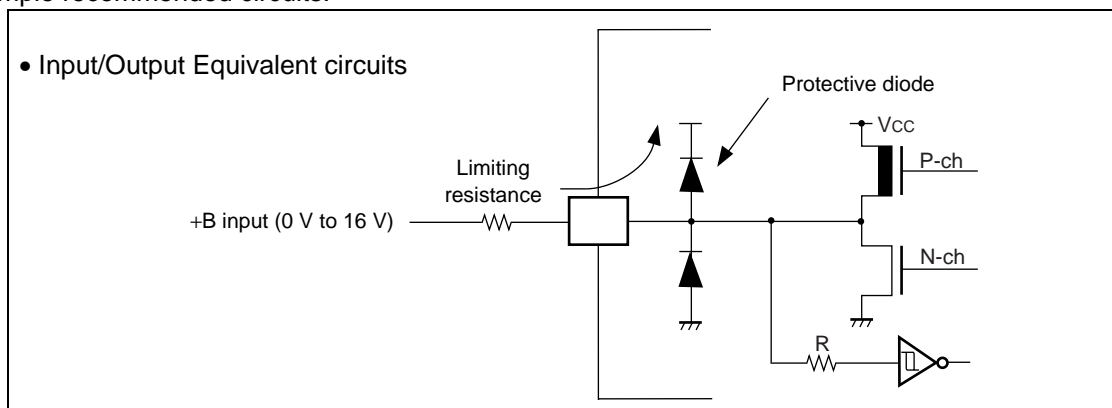

WARNING: Semiconductor devices can be permanently damaged by application of stress (voltage, current, temperature, etc.) in excess of absolute maximum ratings. Do not exceed these ratings.

MB90455 Series

2. Recommended Operating Conditions

($V_{SS} = AV_{SS} = 0.0V$)

Parameter	Symbol	Value			Unit	Remarks
		Min	Typ	Max		
Power supply voltage	V_{CC}	3.5	5.0	5.5	V	Under normal operation
		3.0	—	5.5	V	Retain status of stop operation
	AV_{CC}	4.0	—	5.5	V	*2
Smoothing capacitor	C_S	0.1	—	1.0	μF	*1
Operating temperature	T_A	-40	—	+105	$^{\circ}C$	

*1 : Use a ceramic capacitor, or a capacitor of similar frequency characteristics. On the V_{CC} pin, use a bypass capacitor that has a larger capacity than that of C_S .
Refer to the following figure for connection of smoothing capacitor C_S .

*2 : AV_{CC} is a voltage at which accuracy is guaranteed. AV_{CC} should not exceed V_{CC} .

- C pin connection diagram

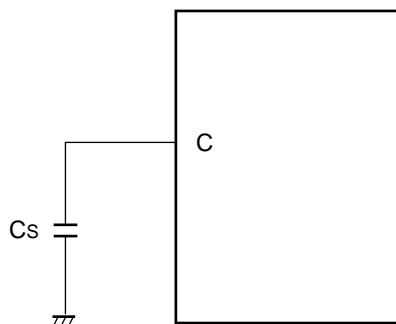

WARNING: The recommended operating conditions are required in order to ensure the normal operation of the semiconductor device. All of the device's electrical characteristics are warranted when the device is operated within these ranges.

Always use semiconductor devices within their recommended operating condition ranges. Operation outside these ranges may adversely affect reliability and could result in device failure.

No warranty is made with respect to uses, operating conditions, or combinations not represented on the data sheet. Users considering application outside the listed conditions are advised to contact their FUJITSU representatives beforehand.

3. DC Characteristics

($V_{CC} = 5.0\text{ V} \pm 10\%$, $V_{SS} = AV_{SS} = 0.0\text{ V}$, $T_A = -40\text{ }^\circ\text{C}$ to $+105\text{ }^\circ\text{C}$)

Parameter	Symbol	Pin name	Conditions	Value			Unit	Remarks
				Min	Typ	Max		
“H” level input voltage	V_{IHS}	CMOS hysteresis input pin	—	$0.8 V_{CC}$	—	$V_{CC} + 0.3$	V	
	V_{IHM}	MD input pin	—	$V_{CC} - 0.3$	—	$V_{CC} + 0.3$	V	
“L” level input voltage	V_{ILS}	CMOS hysteresis input pin	—	$V_{SS} - 0.3$	—	$0.2 V_{CC}$	V	
	V_{ILM}	MD input pin	—	$V_{SS} - 0.3$	—	$V_{SS} + 0.3$	V	
“H” level output voltage	V_{OH1}	Pins other than P14 to P17	$V_{CC} = 4.5\text{ V}$, $I_{OH} = -4.0\text{ mA}$	$V_{CC} - 0.5$	—	—	V	
	V_{OH2}	P14 to P17	$V_{CC} = 4.5\text{ V}$, $I_{OH} = -14.0\text{ mA}$	$V_{CC} - 0.5$	—	—	V	
“L” level output voltage	V_{OL1}	Pins other than P14 to P17	$V_{CC} = 4.5\text{ V}$, $I_{OL} = 4.0\text{ mA}$	—	—	0.4	V	
	V_{OL2}	P14 to P17	$V_{CC} = 4.5\text{ V}$, $I_{OL} = 20.0\text{ mA}$	—	—	0.4	V	
Input leak current	I_{IL}	All input pins	$V_{CC} = 5.5\text{ V}$, $V_{SS} < V_i < V_{CC}$	-5	—	+5	μA	
Power supply current*	I_{CC}	V_{CC}	$V_{CC} = 5.0\text{ V}$, Internally operating at 16 MHz, normal operation.	—	25	30	mA	
			$V_{CC} = 5.0\text{ V}$, Internally operating at 16 MHz, writing on flash memory.	—	45	50	mA	Flash ROM product
			$V_{CC} = 5.0\text{ V}$, Internally operating at 16 MHz, deleting on flash memory.	—	45	50	mA	Flash ROM product
	I_{CCS}		$V_{CC} = 5.0\text{ V}$, Internally operating at 16 MHz, sleeping.	—	8	12	mA	
	I_{CTS}		$V_{CC} = 5.0\text{ V}$, Internally operating at 2 MHz, transition from main clock mode,	—	0.75	1.0	mA	Flash ROM product
			in time-base timer mode.		0.2	0.35	mA	Mask ROM product

(Continued)

MB90455 Series

(Continued)

($V_{CC} = 5.0\text{ V} \pm 10\%$, $V_{SS} = AV_{SS} = 0.0\text{ V}$, $T_A = -40\text{ }^\circ\text{C}$ to $+105\text{ }^\circ\text{C}$)

Parameter	Symbol	Pin name	Conditions	Rating			Unit	Remarks
				Min	Typ	Max		
Power supply current*	I _{CC} L	V _{CC}	V _{CC} = 5.0 V, Internally operating at 8 kHz, subclock operation, T _A = +25°C	—	0.3	1.2	mA	Flash ROM product
				—	40	100	μA	Mask ROM product
	I _{CC} LS		V _{CC} = 5.0 V, Internally operating at 8 kHz, subclock, sleep mode, T _A = +25°C	—	10	30	μA	
	I _{CC} T		V _{CC} = 5.0 V, Internally operating at 8 kHz, clock mode, T _A = +25°C	—	8	25	μA	
	I _{CC} H		Stopping, T _A = +25°C	—	5	20	μA	
Input capacity	C _{IN}	Other than AV _{CC} , AV _{SS} , AVR, C, V _{CC} , V _{SS}	—	—	5	15	pF	
Pull-up resistor	R _{UP}	$\overline{\text{RST}}$	—	25	50	100	kΩ	
Pull-down resistor	R _{DOWN}	MD2	—	25	50	100	kΩ	Flash ROM product is not provided with pull-down resistor.

* : Test conditions of power supply current are based on a device using external clock.

4. AC Characteristics

(1) Clock timing

($V_{CC} = 5.0 V \pm 10\%$, $V_{SS} = AV_{SS} = 0.0 V$, $T_A = -40\text{ }^\circ\text{C}$ to $+105\text{ }^\circ\text{C}$)

Parameter	Symbol	Pin name	Value			Unit	Remarks
			Min	Typ	Max		
Clock frequency	f_C	X0, X1	3	—	8	MHz	When crystal or ceramic resonator is used*2
			3	—	16	MHz	External clock *1, *2
Clock cycle time	t_{HCYL}	X0, X1	125	—	333	ns	
	t_{LCYL}	X0A, X1A	—	30.5	—	μs	
Input clock pulse width	P_{WH}, P_{WL}	X0	10	—	—	ns	Set duty factor at 30% to 70% as a guideline.
	P_{WLH}, P_{WLL}	X0A	—	15.2	—	μs	
Input clock rise time and fall time	t_{CR}, t_{CF}	X0	—	—	5	ns	When external clock is used
Internal operation clock frequency	f_{CP}	—	1.5	—	16	MHz	When main clock is used
	f_{LCP}	—	—	8.192	—	kHz	When sub clock is used
Internal operation clock cycle time	t_{CP}	—	62.5	—	666	ns	When main clock is used
	t_{LCP}	—	—	122.1	—	μs	When sub clock is used

*1 : Internal operation clock frequency should not exceed 16 MHz.

*2 : When selecting the PLL clock, the range of clock frequency is limited. Use this product within range as mentioned in "Relation among external clock frequency and internal clock frequency".

• Clock timing

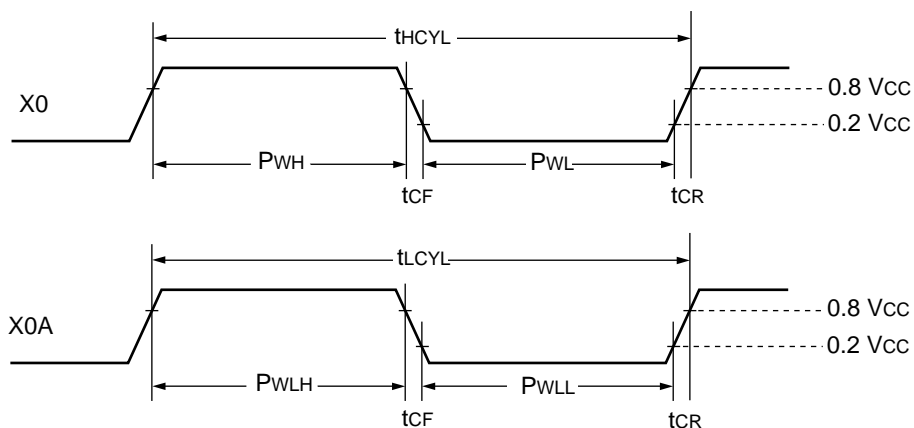

MB90455 Series

- PLL operation guarantee range

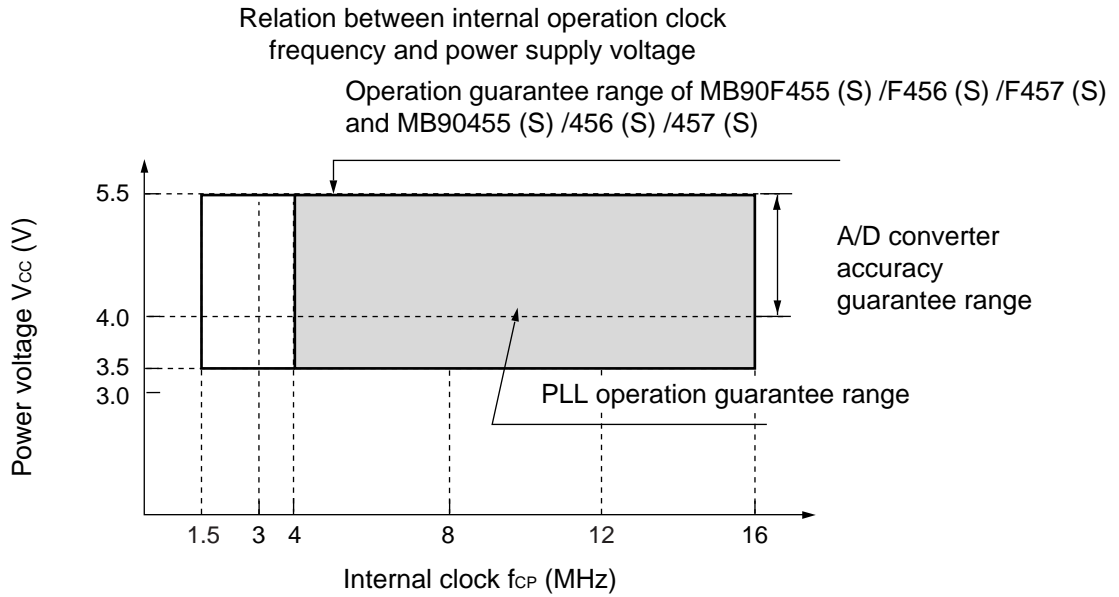

Relation among external clock frequency and internal clock frequency

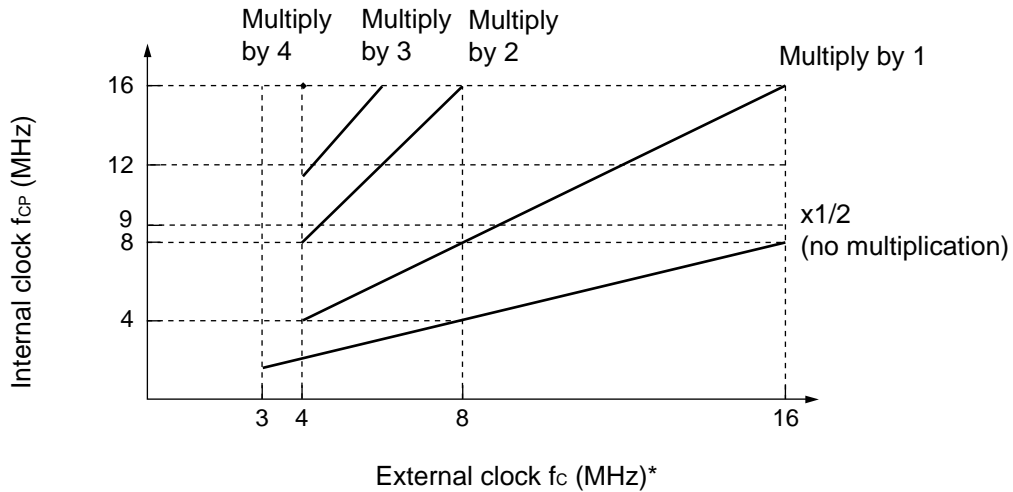

* : f_c is 8 MHz at maximum when crystal or ceramic resonator is used.

Rating values of alternating current is defined by the measurement reference voltage values shown below:

- Input signal waveform

Hysteresis input pin

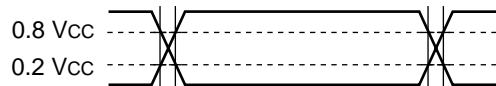

- Output signal waveform

Output pin

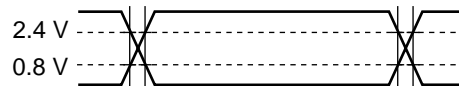

(2) Reset input timing

Parameter	Symbol	Pin name	Conditions	Value		Unit	Remarks
				Min	Max		
Reset input time	t_{RSTL}	\overline{RST}	—	$16 t_{CP}^{*3}$	—	ns	Normal operation
				Oscillation time of oscillator* ¹ + $100 \mu s + 16 t_{CP}^{*3}$	—	—	In sub clock* ² , sub sleep* ² , watch* ² and stop mode
				100	—	μs	In time base timer mode

*1 : Oscillation time of oscillator is time until oscillation reaches 90% of amplitude. It takes several milliseconds to several dozens of milliseconds on a crystal oscillator, several hundreds of microseconds to several milliseconds on a FAR/ceramic oscillator, and 0 milliseconds on an external clock.

*2 : Except for MB90F455S/F456S/F457S, MB90455S/456S/457S.

*3 : Refer to "(1) Clock timing" ratings for t_{CP} (internal operation clock cycle time).

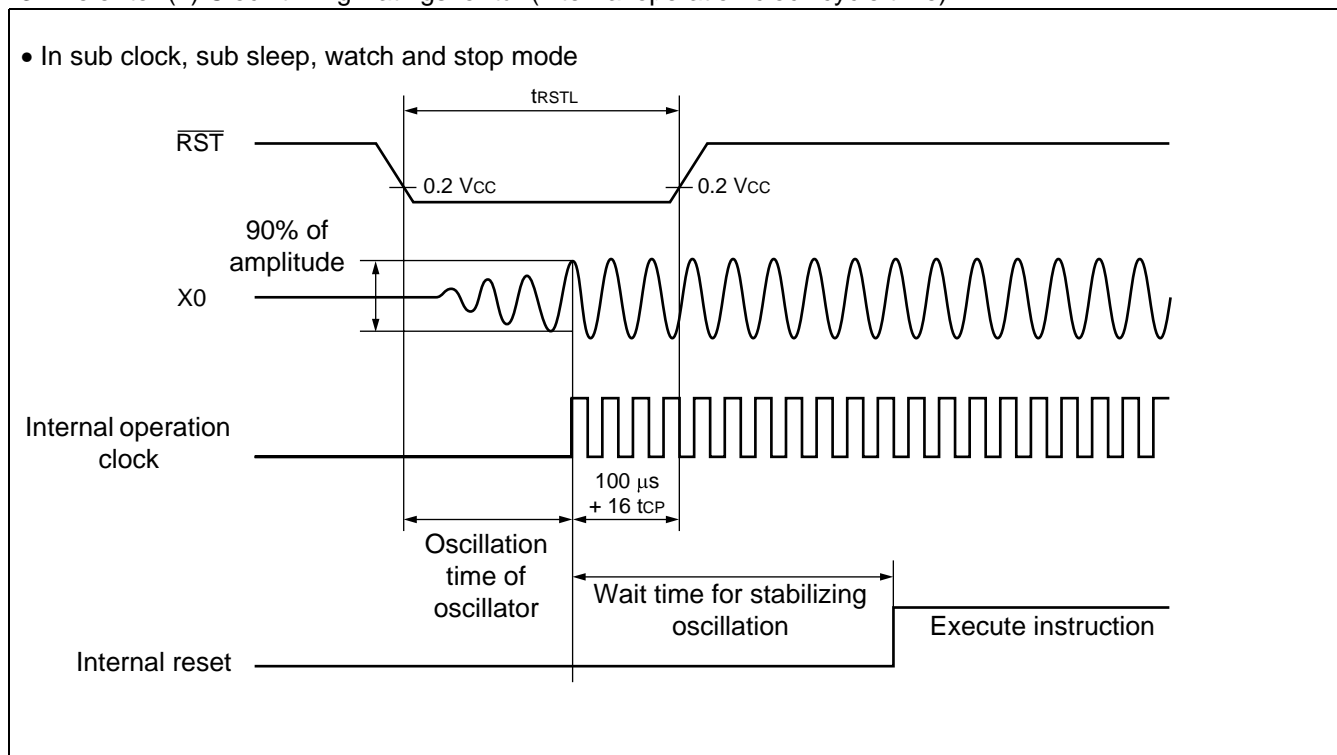

MB90455 Series

(3) Power-on reset

($V_{CC} = 5.0 \text{ V} \pm 10\%$, $V_{SS} = AV_{SS} = 0.0 \text{ V}$, $T_A = -40 \text{ }^\circ\text{C}$ to $+105 \text{ }^\circ\text{C}$)

Parameter	Symbol	Pin name	Conditions	Value		Unit	Remarks
				Min	Max		
Power supply rise time	t_r	V_{CC}	—	0.05	30	ms	
Power supply shutdown time	t_{OFF}	V_{CC}		1	—	ms	Repeated operation

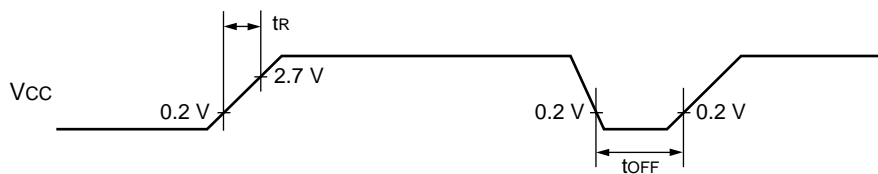

Sudden change of power supply voltage may activate the power-on reset function. When changing power supply voltages during operation, raise the power smoothly by suppressing variation of voltages as shown below. When raising the power, do not use PLL clock. However, if voltage drop is 1V/s or less, use of PLL clock is allowed during operation.

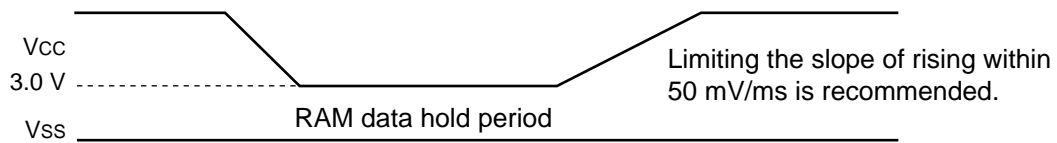

(4) UART timing

(V_{CC} = 4.5 V to 5.5 V, V_{SS} = 0.0 V, T_A = -40 °C to +105 °C)

Parameter	Symbol	Pin name	Conditions	Value		Unit	Remarks
				Min	Max		
Serial clock cycle time	t _{SCYC}	SCK1	Internal shift clock mode output pin is : CL = 80 pF+1TTL.	8 t _{CP} *	—	ns	
SCK ↓ → SOT delay time	t _{SLOV}	SCK1, SOT1		-80	+80	ns	
Valid SIN → SCK ↑	t _{IVSH}	SCK1, SIN1		100	—	ns	
SCK ↑ → valid SIN hold time	t _{SHIX}	SCK1, SIN1		60	—	ns	
Serial clock "H" pulse width	t _{SHSL}	SCK1	External shift clock mode output pin is : CL = 80 pF+1TTL.	4 t _{CP} *	—	ns	
Serial clock "L" pulse width	t _{LSLH}	SCK1		4 t _{CP} *	—	ns	
SCK ↓ → SOT delay time	t _{SLOV}	SCK1, SOT1		—	150	ns	
Valid SIN → SCK ↑	t _{IVSH}	SCK1, SIN1		60	—	ns	
SCK ↑ → valid SIN hold time	t _{SHIX}	SCK1, SIN1		60	—	ns	

* : Refer to "(1) Clock timing" ratings for t_{CP} (internal operation clock cycle time).

- Notes:
- AC rating in CLK synchronous mode.
 - C_L is a load capacitance value on pins for testing.

MB90455 Series

- Internal shift clock mode

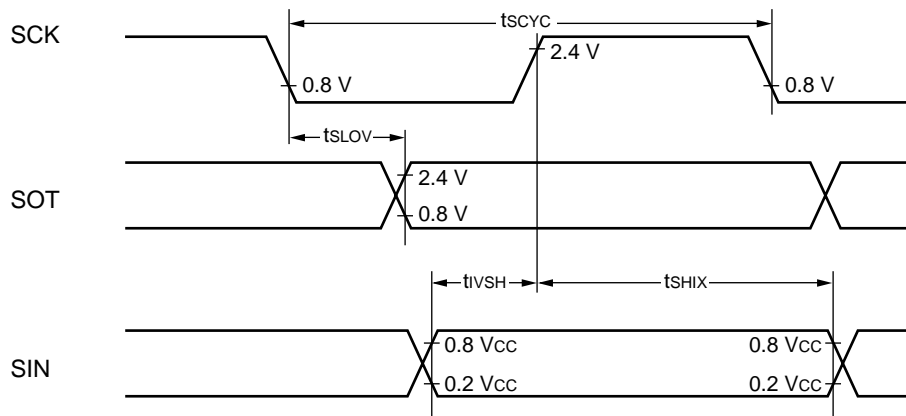

- External shift clock mode

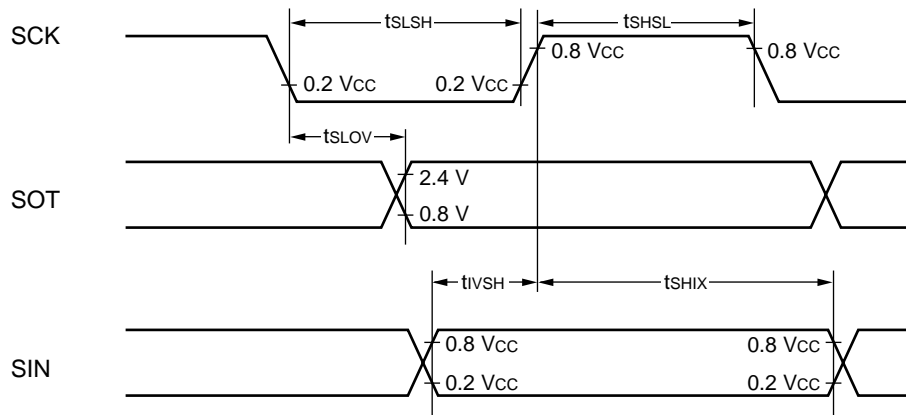

(5) Timer input timing

($V_{CC} = 4.5\text{ V to }5.5\text{ V}$, $V_{SS} = 0.0\text{ V}$, $T_A = -40\text{ }^\circ\text{C to }+105\text{ }^\circ\text{C}$)

Parameter	Symbol	Pin name	Conditions	Value		Unit	Remarks
				Min	Max		
Input pulse width	t_{TIWH}	TIN0, TIN1	—	4 t_{CP} *	—	ns	
	t_{TIWL}	IN0 to IN3					

* : Refer to "(1) Clock timing" ratings for t_{CP} (internal operation clock cycle time).

• Timer input timing

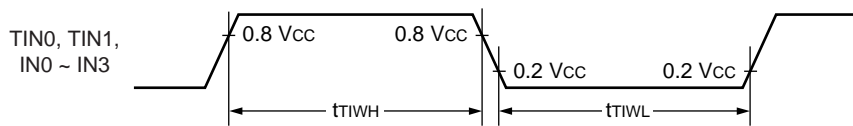

(6) Trigger input timing

($V_{CC} = 4.5\text{ V to }5.5\text{ V}$, $V_{SS} = 0.0\text{ V}$, $T_A = -40\text{ }^\circ\text{C to }+105\text{ }^\circ\text{C}$)

Parameter	Symbol	Pin name	Conditions	Value		Unit	Remarks
				Min	Max		
Input pulse width	t_{TRGH}	INT4 to INT7, ADTG	—	5 t_{CP} *	—	ns	
	t_{TRGL}						

* : Refer to "(1) Clock timing" ratings for t_{CP} (internal operation clock cycle time).

• Trigger input timing

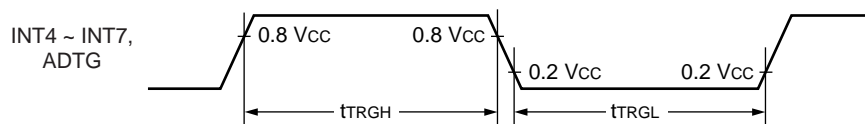

MB90455 Series

5. A/D converter

($V_{CC} = AV_{CC} = 5.0 \text{ V} \pm 10\%$, $V_{SS} = AV_{SS} = 0.0 \text{ V}$, $3.0 \text{ V} \leq AVR - AV_{SS}$, $T_A = -40 \text{ }^\circ\text{C}$ to $+105 \text{ }^\circ\text{C}$)

Parameter	Symbol	Pin name	Conditions	Value		Unit	Remarks
				Min	Max		
Resolution	—	—	—	—	10	bit	
Total error	—	—	—	—	± 3.0	LSB	
Nonlinear error	—	—	—	—	± 2.5	LSB	
Differential linear error	—	—	—	—	± 1.9	LSB	
Zero transition voltage	V_{OT}	AN0 to AN7	$AV_{SS} - 1.5$ LSB	$AV_{SS} + 0.5$ LSB	$AV_{SS} + 2.5$ LSB	V	1 LSB = AVR/1024
Full-scale transition voltage	V_{FST}	AN0 to AN7	$AVR - 3.5$ LSB	$AVR - 1.5$ LSB	$AVR + 0.5$ LSB	V	
Compare time	—	—	$66 t_{CP}^{*1}$	—	—	ns	With 16 MHz machine clock $5.5 \text{ V} \geq AV_{CC} \geq 4.5 \text{ V}$
			$88 t_{CP}^{*1}$	—	—	ns	With 16 MHz machine clock $4.5 \text{ V} > AV_{CC} \geq 4.0 \text{ V}$
Sampling time	—	—	$32 t_{CP}^{*1}$	—	—	ns	With 16 MHz machine clock $5.5 \text{ V} \geq AV_{CC} \geq 4.5 \text{ V}$
			$128 t_{CP}^{*1}$	—	—	ns	With 16 MHz machine clock $4.5 \text{ V} > AV_{CC} \geq 4.0 \text{ V}$
Analog port input current	I_{AIN}	AN0 to AN7	—	—	10	μA	
Analog input voltage	V_{AIN}	AN0 to AN7	AV_{SS}	—	AVR	V	
Reference voltage	—	AVR	$AV_{SS} + 2.7$	—	AV_{CC}	V	
Power supply current	I_A	AV_{CC}	—	3.5	7.5	mA	
	I_{AH}	AV_{CC}	—	—	5	μA	*2
Reference voltage supplying current	I_R	AVR	—	165	250	μA	
	I_{RH}	AVR	—	—	5	μA	*2
Variation among channels	—	AN0 to AN7	—	—	4	LSB	

*1 : Refer to "(1) Clock timing" ratings for t_{CP} (internal operation clock cycle time).

*2 : If A/D converter is not operating, a current when CPU is stopped is applicable ($V_{CC}=AV_{CC}=AVR=5.0 \text{ V}$).

6. Definition of A/D Converter Terms

- Resolution : Analog variation that is recognized by an A/D converter.
- Linear error : Deviation between a line across zero-transition line (“00 0000 00 0 0” ↔ “00 0000 0001”) and full-scale transition line (“11 1111 11 1 0” ↔ “11 1111 1111”) and actual conversion characteristics.
- Differential linear error : Deviation of input voltage, that is required for changing output code by 1 LSB, from an ideal value.
- Total error : Difference between an actual value and an ideal value. A total error includes zero transition error, full-scale transition error, and linear error.

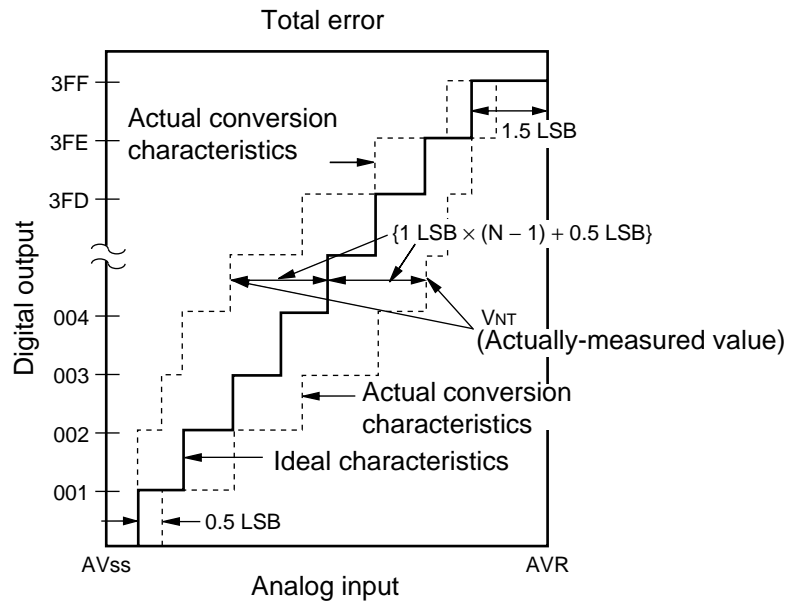

$$\text{Total error of digital output "N"} = \frac{V_{NT} - \{1 \text{ LSB} \times (N - 1) + 0.5 \text{ LSB}\}}{1 \text{ LSB}} \text{ [LSB]}$$

$$1 \text{ LSB} = (\text{Ideal value}) \frac{AVR - AV_{SS}}{1024} \text{ [V]}$$

$$V_{OT} (\text{Ideal value}) = AV_{SS} + 0.5 \text{ LSB [V]}$$

$$V_{FST} (\text{Ideal value}) = AVR - 1.5 \text{ LSB [V]}$$

V_{NT} : A voltage at which digital output transits from (N-1) to N.

(Continued)

MB90455 Series

(Continued)

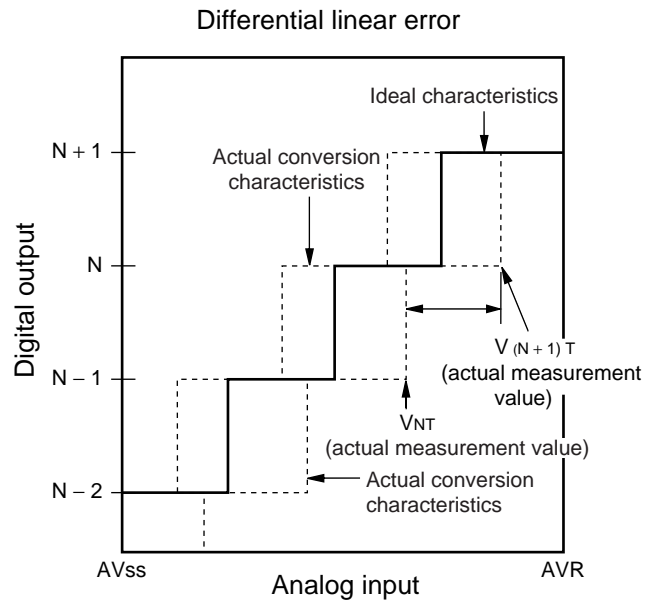
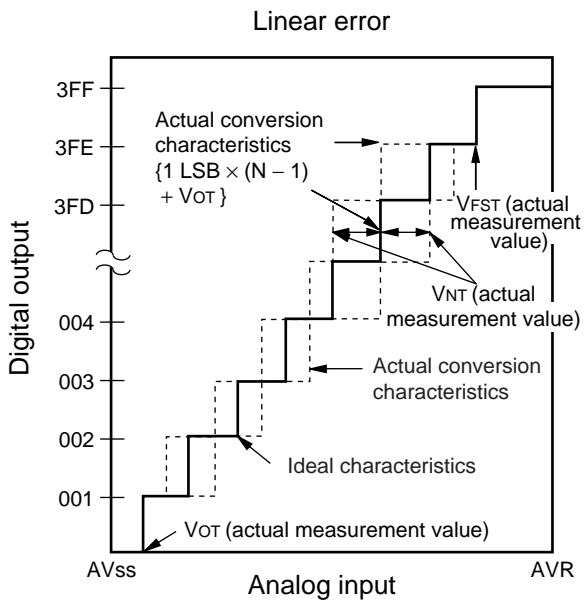

$$\text{Linear error of digital output } N = \frac{V_{NT} - \{1 \text{ LSB} \times (N - 1) + V_{OT}\}}{1 \text{ LSB}} \text{ [LSB]}$$

$$\text{Differential linear error of digital output } N = \frac{V_{(N+1)T} - V_{NT}}{1 \text{ LSB}} - 1 \text{ LSB [LSB]}$$

$$1 \text{ LSB} = \frac{V_{FST} - V_{OT}}{1022} \text{ [V]}$$

V_{OT} : Voltage at which digital output transits from "000H" to "001H."

V_{FST} : Voltage at which digital output transits from "3FEH" to "3FFH."

7. Notes on A/D Converter Section

Use the device with external circuits of the following output impedance for analog inputs:

Recommended output impedance of external circuits are: Approx. 3.9 kΩ or lower ($4.5\text{ V} \leq AV_{CC} \leq 5.5\text{ V}$) (sampling period=2.00 μs at 16-MHz machine clock), Approx. 11 kΩ or lower ($4.0\text{ V} \leq AV_{CC} < 4.5\text{ V}$) (sampling period=8.0 μs at 16-MHz machine clock).

If an external capacitor is used, in consideration of the effect by tap capacitance caused by external capacitors and on-chip capacitors, capacitance of the external one is recommended to be several thousand times as high as internal capacitor.

If output impedance of an external circuit is too high, a sampling period for an analog voltage may be insufficient.

• Analog input circuit model

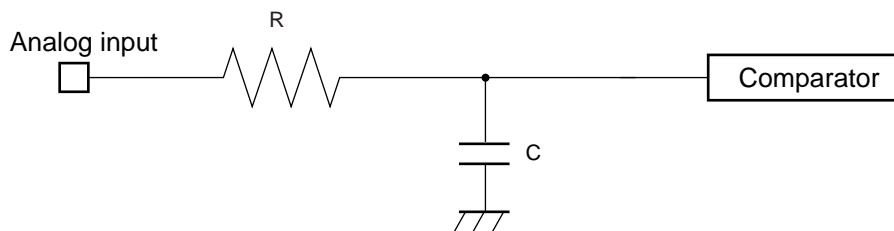

MB90F455 (S) /F456 (S) /F457 (S) and MB90455 (S) /456 (S) /457 (S)
 $4.5\text{ V} \leq AV_{CC} \leq 5.5\text{ V}$ $R \approx 2.35\text{ k}\Omega$, $C \approx 36.4\text{ pF}$
 $4.0\text{ V} \leq AV_{CC} < 4.5\text{ V}$ $R \approx 16.4\text{ k}\Omega$, $C \approx 36.4\text{ pF}$

Note : Use the values in the figure only as a guideline.

• About errors

As [AVR-AVss] become smaller, values of relative errors grow larger.

8. Flash Memory Program/Erase Characteristics

Parameter	Conditions	Value			Unit	Remarks
		Min	Typ	Max		
Sector eraset time	$T_A = +25\text{ }^\circ\text{C}$ $V_{CC} = 5.0\text{ V}$	—	1	15	s	Excludes 00H programming prior to erasure
Chip erase time		—	4	—	s	Excludes 00H programming prior to erasure
Word (16 bit width) programming time		—	16	3,600	μs	Except for the over head time of the system
Program/Erase cycle	—	10,000	—	—	cycle	

MB90455 Series

EXAMPLE CHARACTERISTICS

- MB90F457

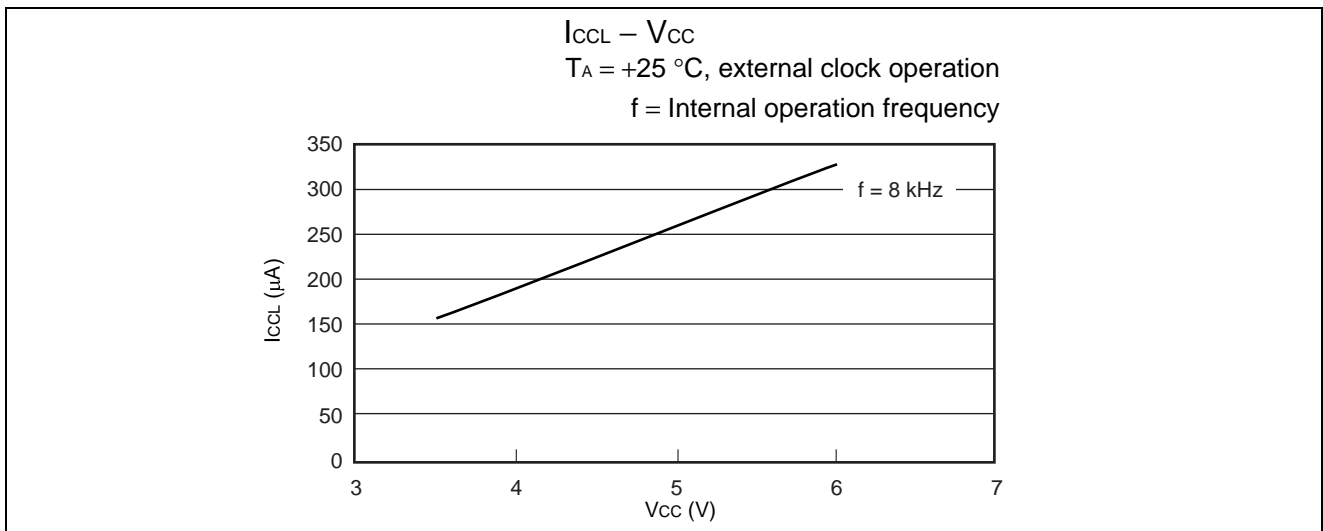
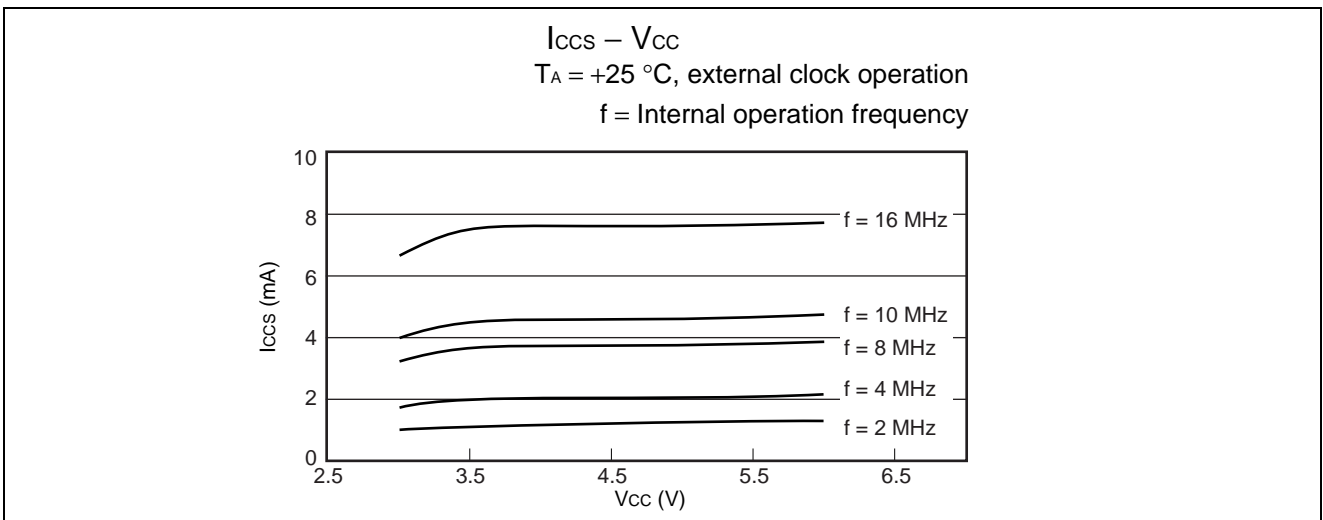
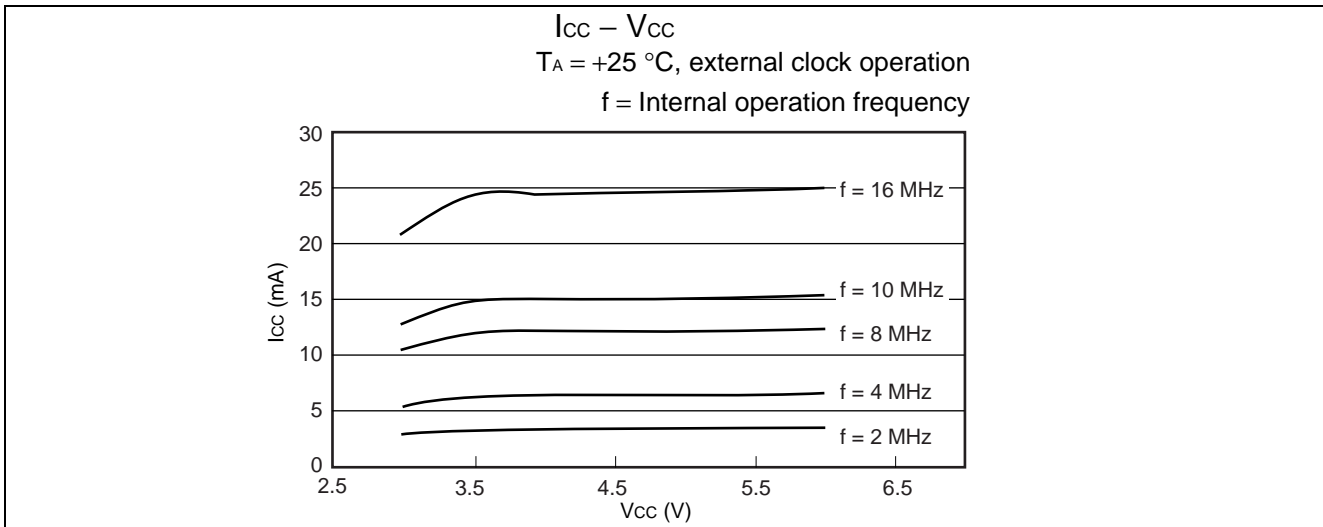

(Continued)

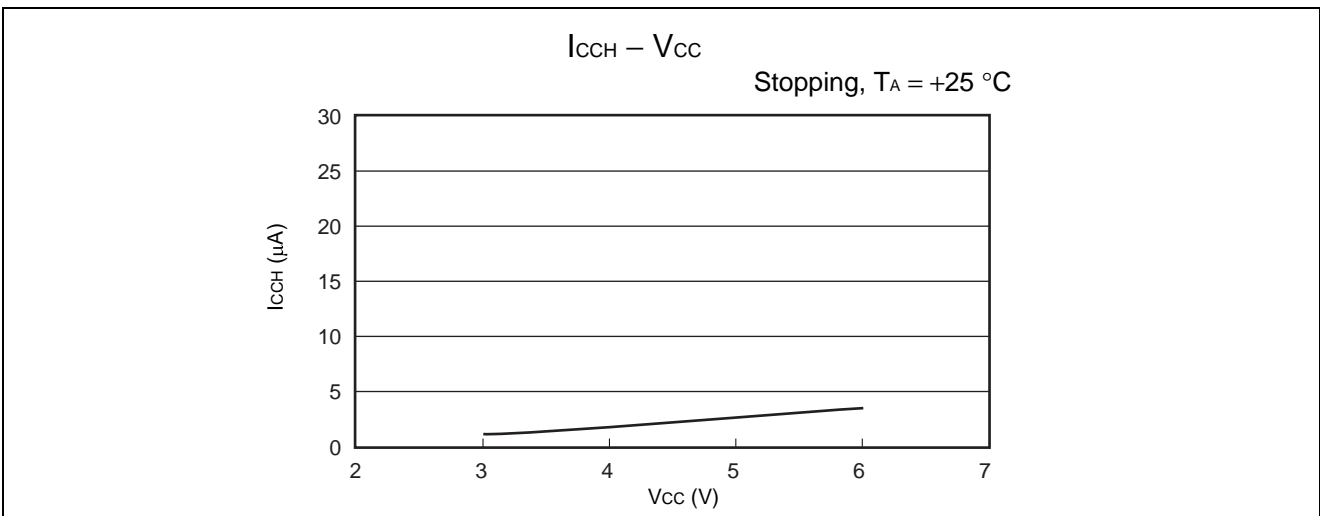
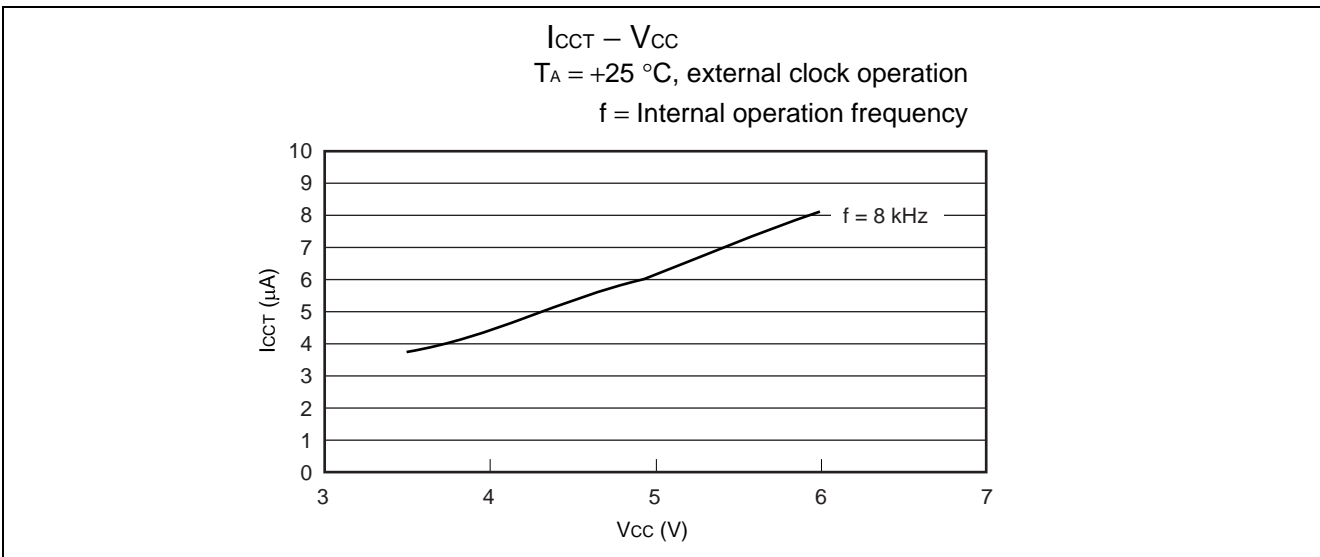
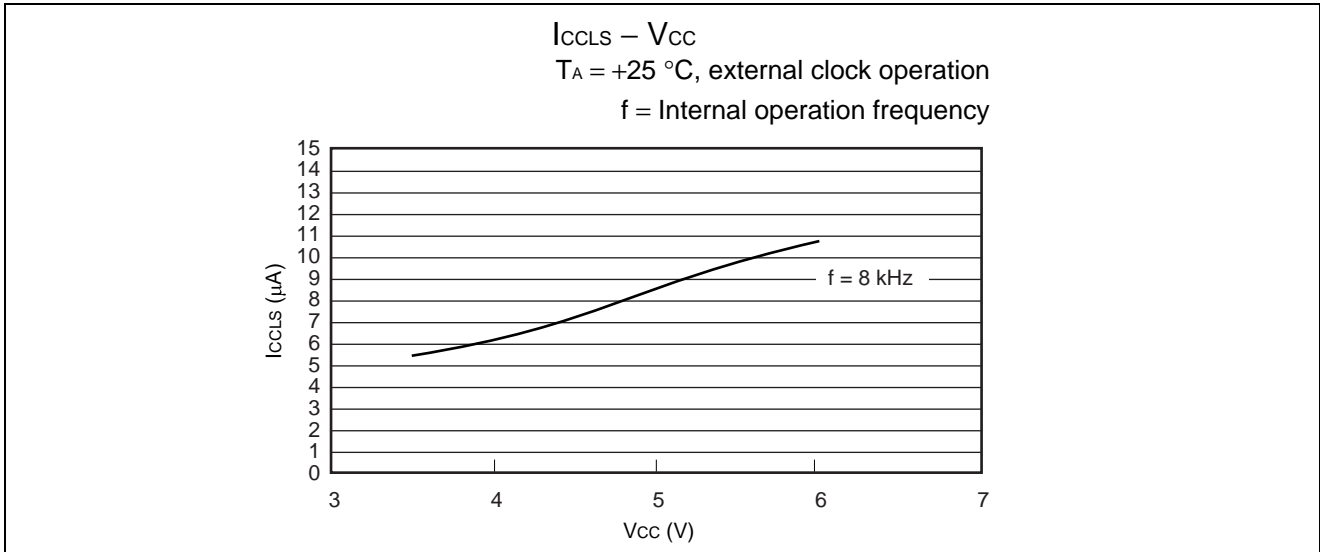

(Continued)

MB90455 Series

(Continued)

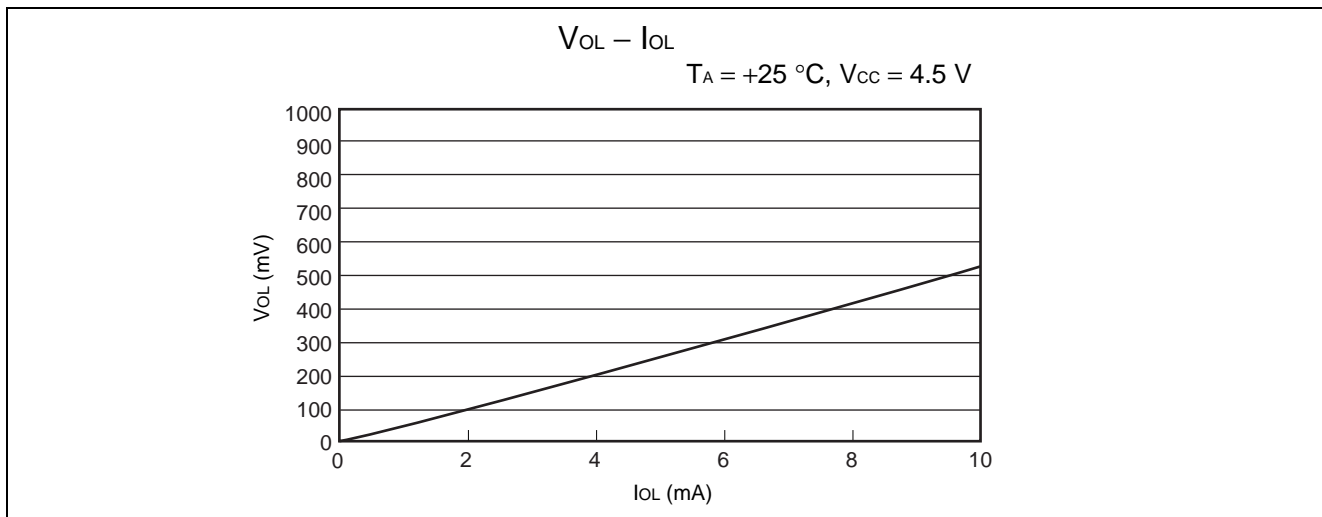
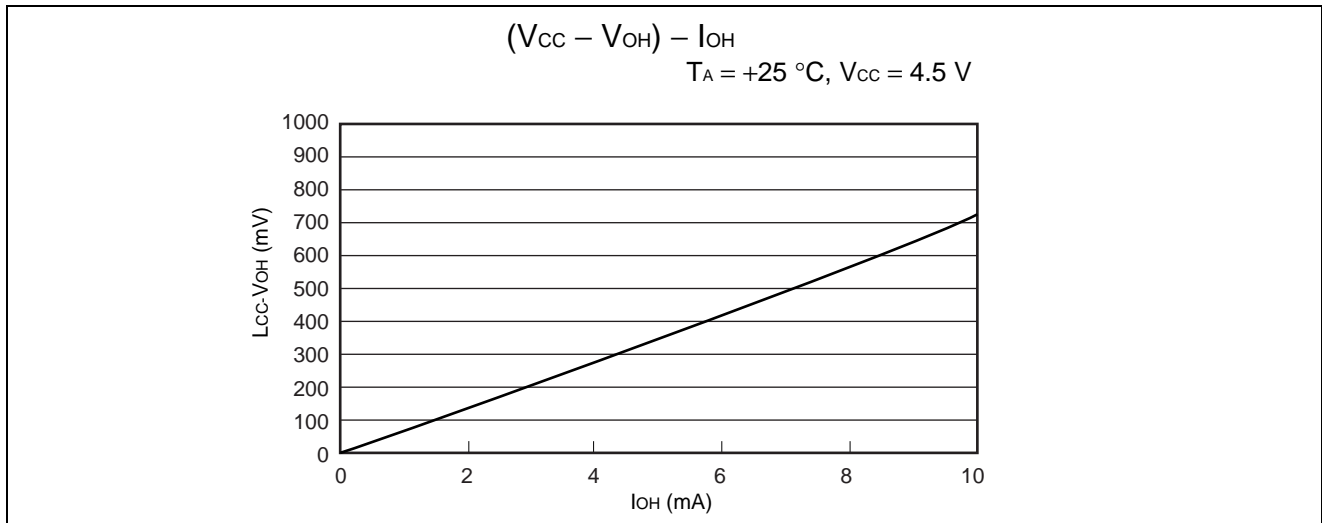

“H” level input voltage/ “L” level input voltage

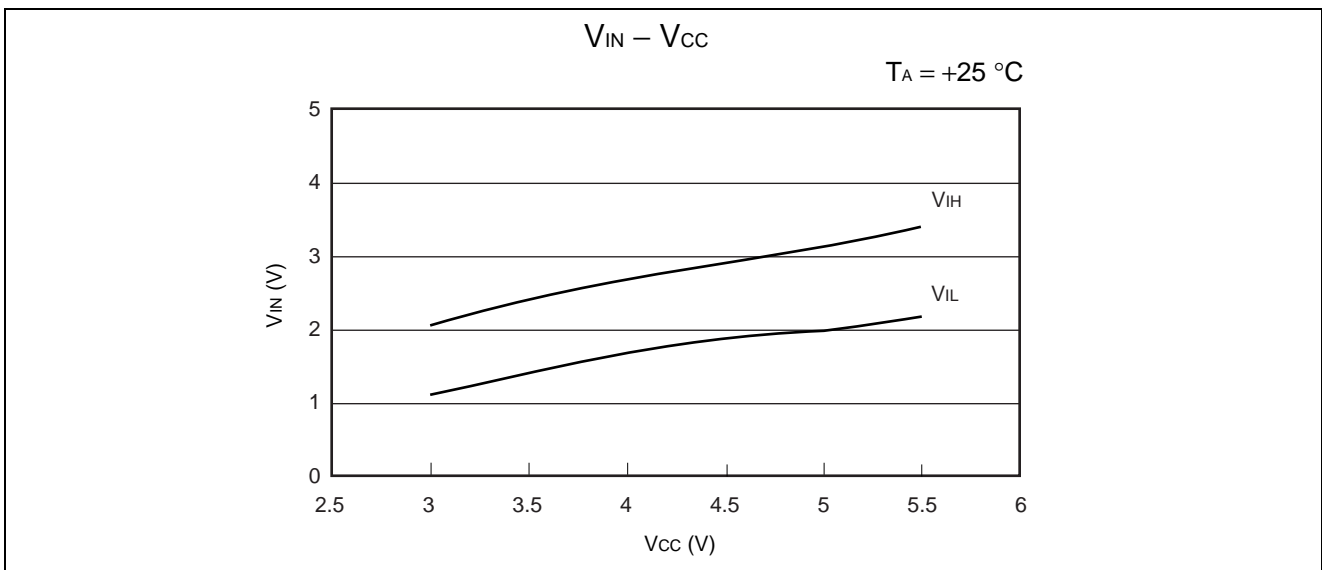

• MB90457

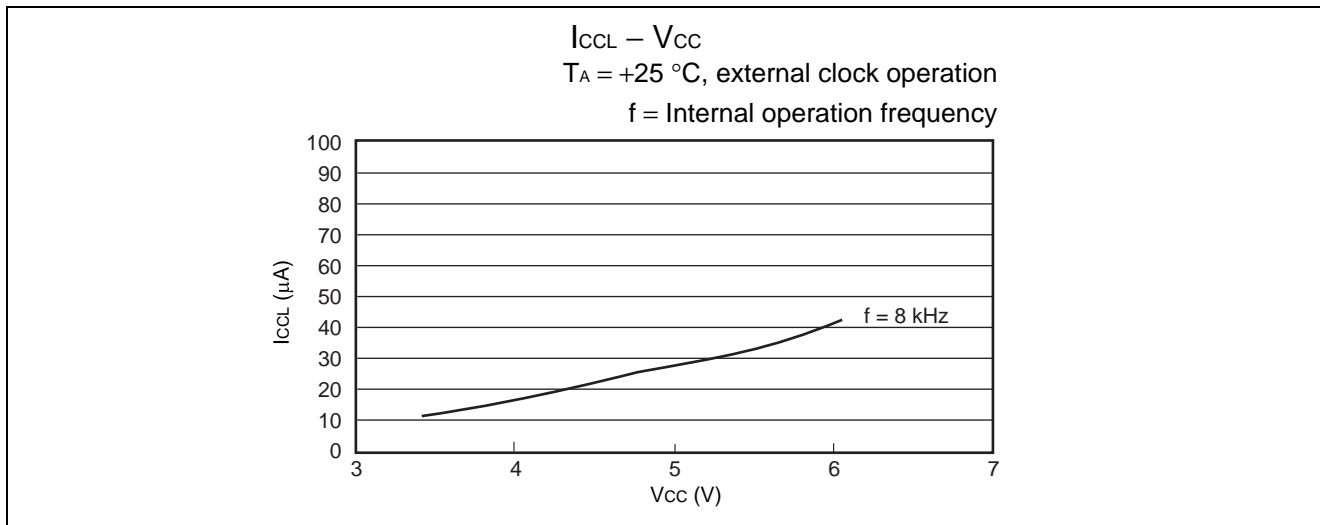
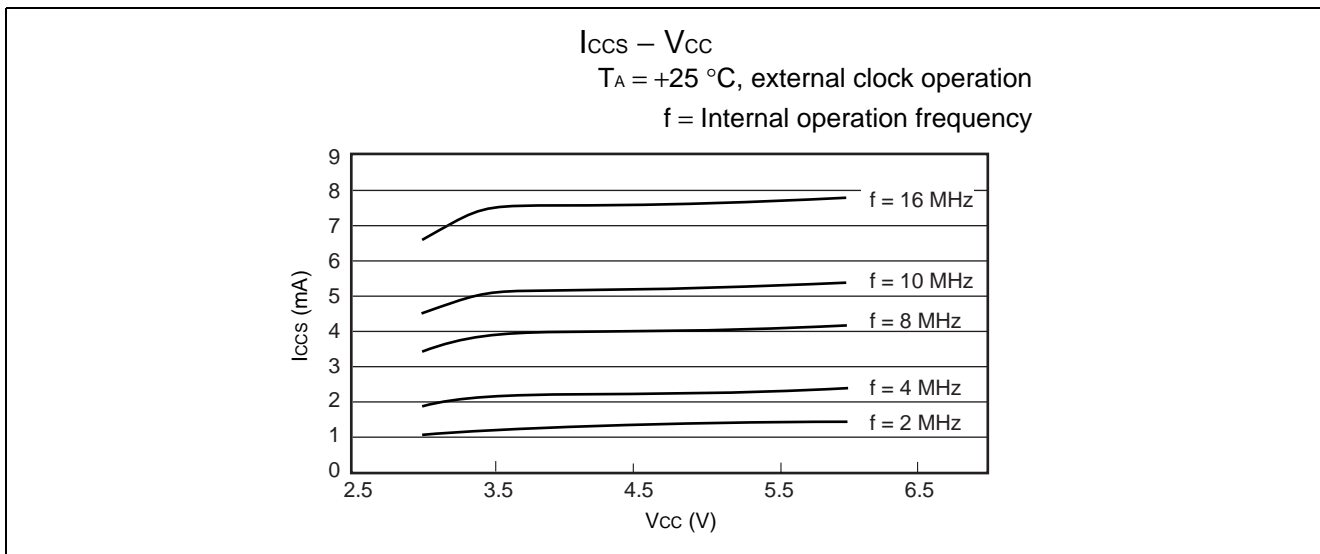
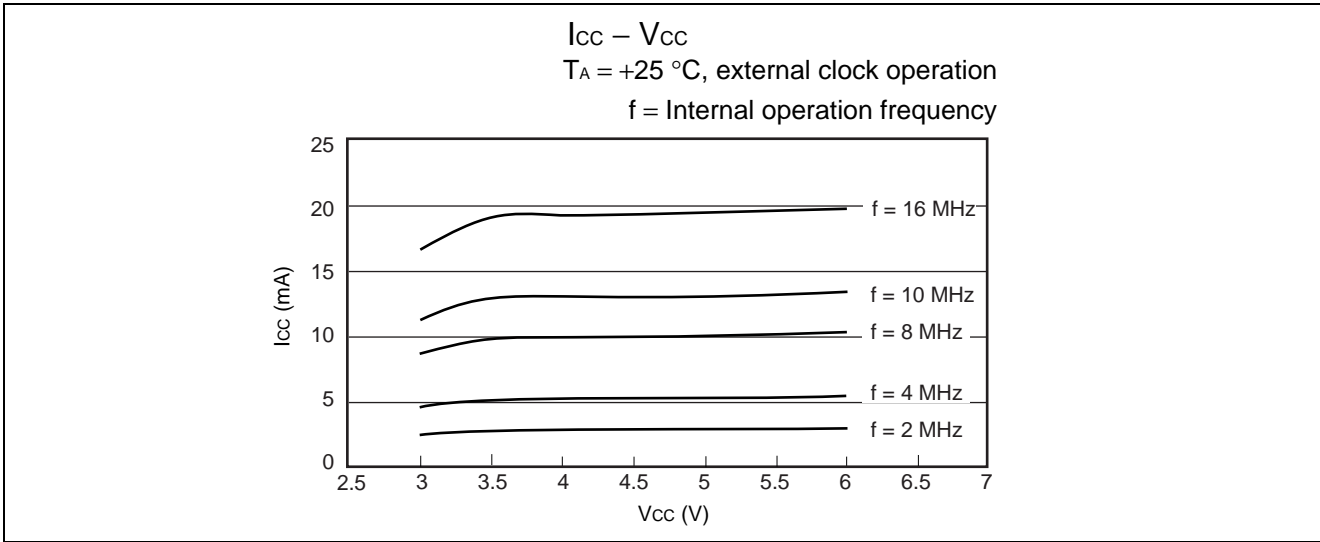

(Continued)

MB90455 Series

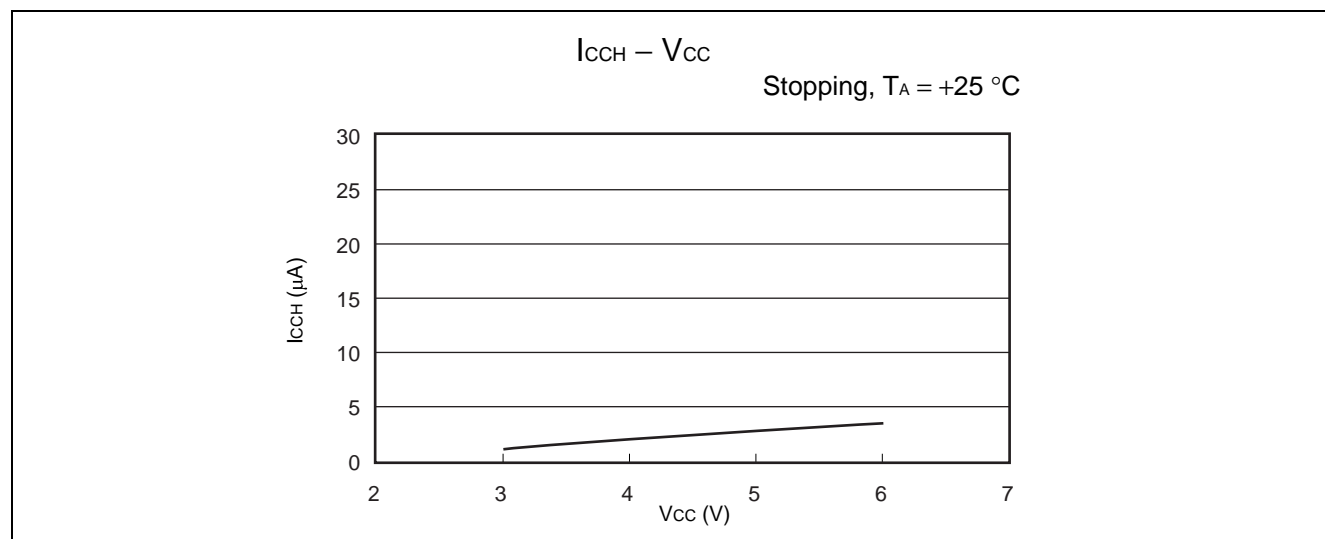
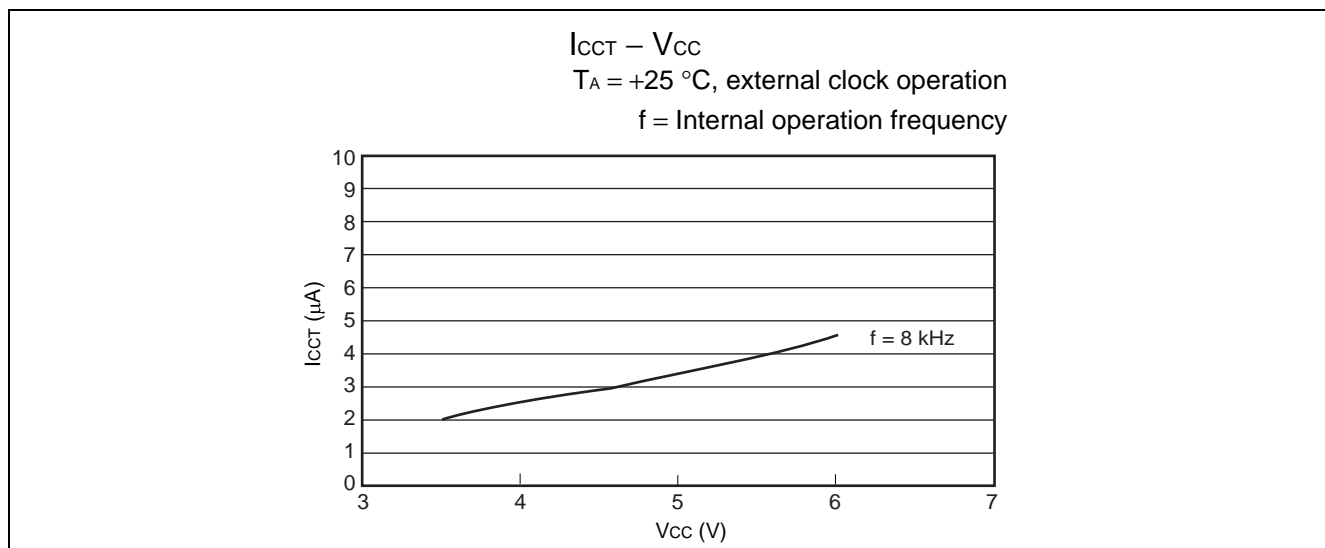
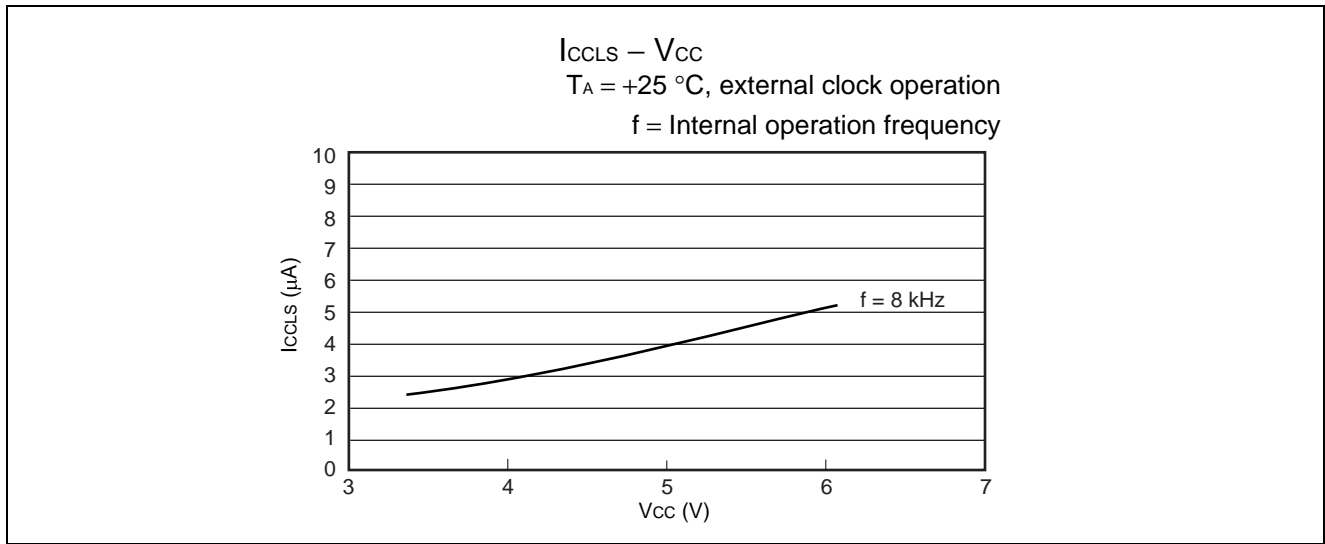

(Continued)

(Continued)

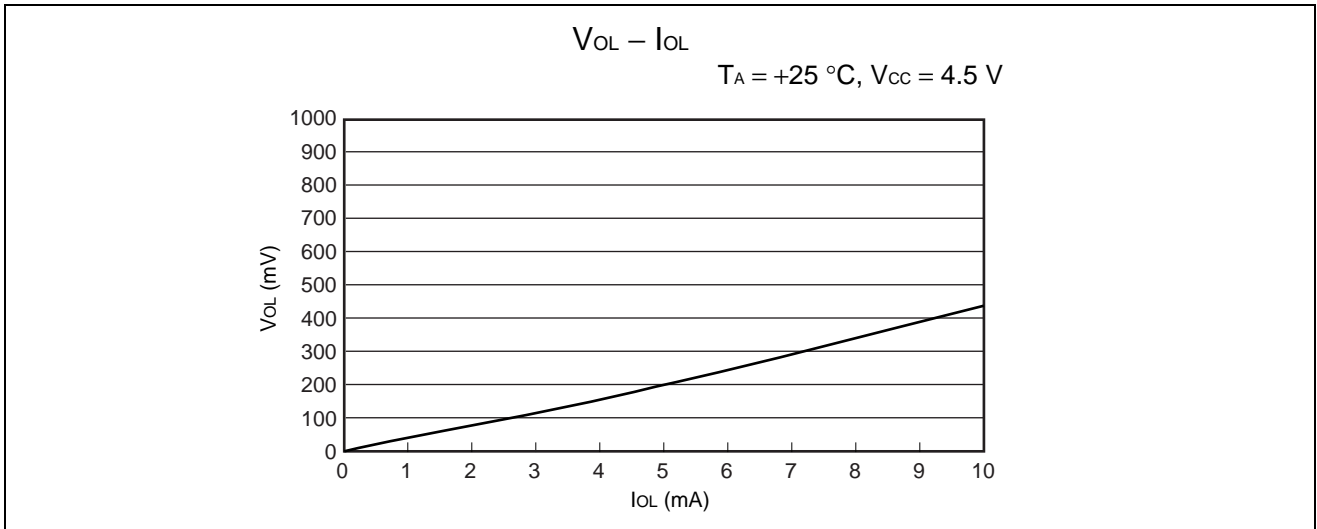
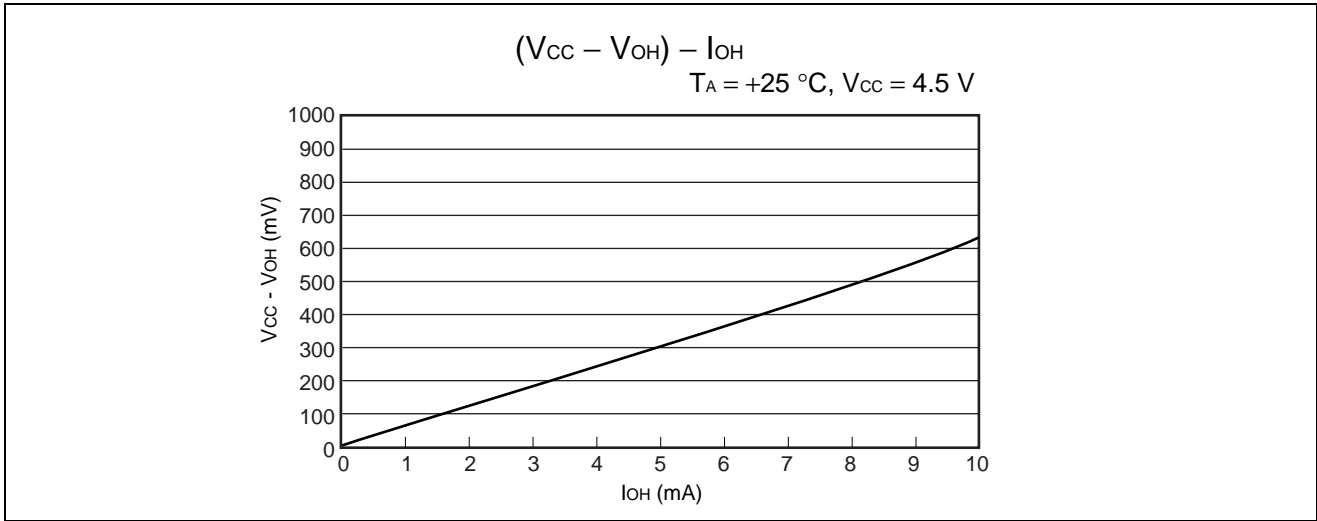

“H” level input voltage/ “L” level input voltage

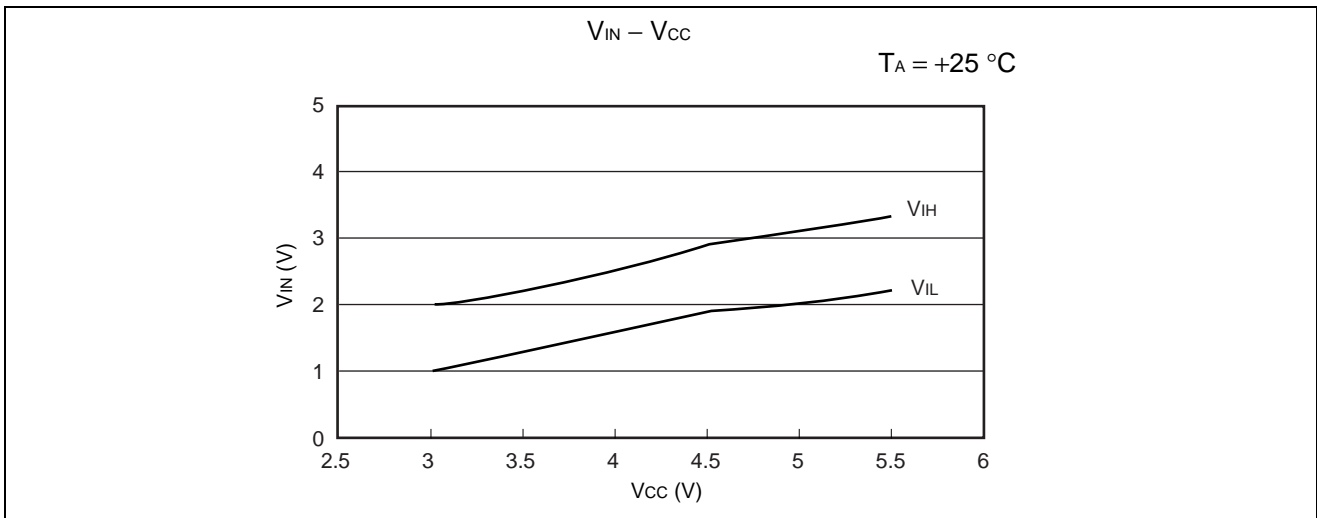

MB90455 Series

■ ORDERING INFORMATION

Part number	Package	Remarks
MB90F455PMT MB90F456PMT MB90F457PMT MB90455PMT MB90456PMT MB90457PMT MB90F455SPMT MB90F456SPMT MB90F457SPMT MB90455SPMT MB90456SPMT MB90457SPMT	48-pin plastic LQFP (FPT-48P-M26)	

PACKAGE DIMENTION

48-pin plastic LQFP
(FPT-48P-M26)

Note : Pins width and pins thickness include plating tackiness.

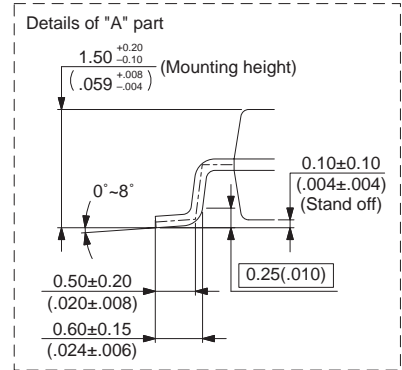
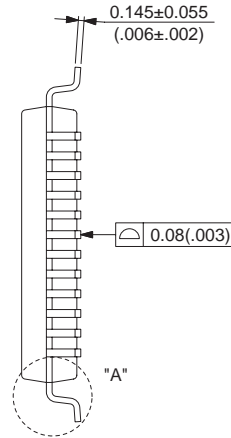
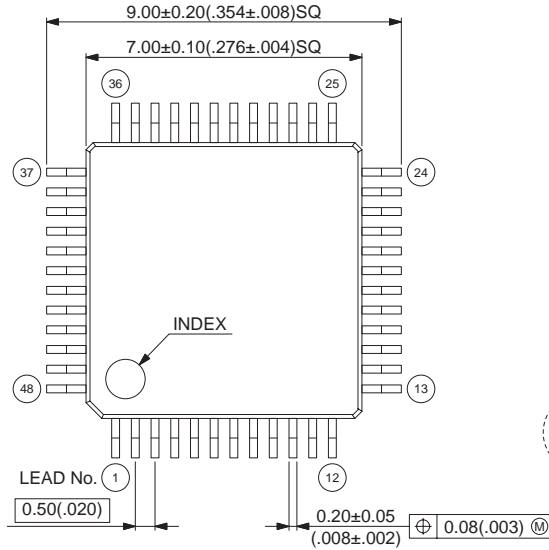

© 2001 FUJITSU LIMITED F48040S-c-1-1

Dimensions in mm (inches)

FUJITSU LIMITED

All Rights Reserved.

The contents of this document are subject to change without notice. Customers are advised to consult with FUJITSU sales representatives before ordering.

The information and circuit diagrams in this document are presented as examples of semiconductor device applications, and are not intended to be incorporated in devices for actual use. Also, FUJITSU is unable to assume responsibility for infringement of any patent rights or other rights of third parties arising from the use of this information or circuit diagrams.

The products described in this document are designed, developed and manufactured as contemplated for general use, including without limitation, ordinary industrial use, general office use, personal use, and household use, but are not designed, developed and manufactured as contemplated (1) for use accompanying fatal risks or dangers that, unless extremely high safety is secured, could have a serious effect to the public, and could lead directly to death, personal injury, severe physical damage or other loss (i.e., nuclear reaction control in nuclear facility, aircraft flight control, air traffic control, mass transport control, medical life support system, missile launch control in weapon system), or (2) for use requiring extremely high reliability (i.e., submersible repeater and artificial satellite).

Please note that Fujitsu will not be liable against you and/or any third party for any claims or damages arising in connection with above-mentioned uses of the products.

Any semiconductor devices have an inherent chance of failure. You must protect against injury, damage or loss from such failures by incorporating safety design measures into your facility and equipment such as redundancy, fire protection, and prevention of over-current levels and other abnormal operating conditions.

If any products described in this document represent goods or technologies subject to certain restrictions on export under the Foreign Exchange and Foreign Trade Law of Japan, the prior authorization by Japanese government will be required for export of those products from Japan.

F0208

© FUJITSU LIMITED Printed in Japan