

## Single Phase Bi-directional Power/Energy IC

### Features

- Energy Data Linearity:  $\pm 0.1\%$  of Reading over 1000:1 Dynamic Range
- On-chip Functions:
  - Instantaneous Voltage, Current, and Power
  - $I_{RMS}$  and  $V_{RMS}$ , Apparent and Active (Real) Power
  - Energy-to-pulse Conversion for Mechanical Counter/Stepper Motor Drive
  - System Calibrations and Phase Compensation
  - Temperature Sensor
  - Voltage Sag Detect
- Meets Accuracy Spec for IEC, ANSI, & JIS
- Power Consumption <12 mW
- Current Input Optimized for Sense Resistor
- GND-referenced Signals with Single Supply
- On-chip 2.5 V Reference (25 ppm/°C typ)
- Power Supply Monitor
- Simple Three-wire Digital Serial Interface
- "Auto-boot" Mode from Serial E<sup>2</sup>PROM.
- Power Supply Configurations  
 $V_{A+} = +5\text{ V}$ ;  $AGND = 0\text{ V}$ ;  $V_{D+} = +3.3\text{ V to }+5\text{ V}$

### Description

The CS5461A is an integrated power measurement device which combines two  $\Delta\Sigma$  analog-to-digital converters, power calculation engine, energy-to-frequency converter, and a serial interface on a single chip. It is designed to accurately measure instantaneous current and voltage, and calculate  $V_{RMS}$ ,  $I_{RMS}$ , instantaneous power, apparent power, and active power for single-phase, 2- or 3-wire power metering applications.

The CS5461A is optimized to interface to shunt resistors or current transformers for current measurement, and to resistive dividers or potential transformers for voltage measurement.

The CS5461A features a bi-directional serial interface for communication with a processor and a programmable energy-to-pulse output function. Additional features include on-chip functionality to facilitate system-level calibration, temperature sensor, voltage sag detection, and phase compensation.

### ORDERING INFORMATION:

CS5461A-ISZ -40° to 85° C 24-pin SSOP Lead Free

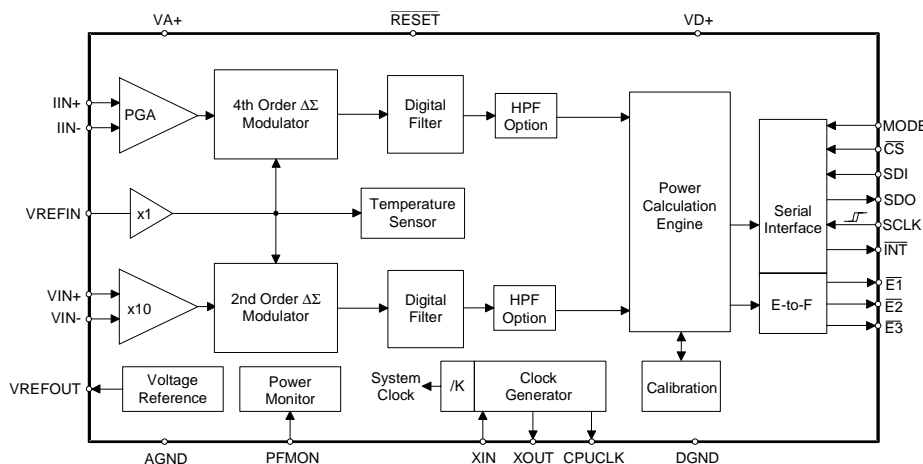

**Preliminary Product Information**

This document contains information for a new product. Cirrus Logic reserves the right to modify this product without notice.

---

**TABLE OF CONTENTS**

<b>1. General Description</b>	<b>5</b>
<b>2. Pin Description</b>	<b>6</b>
<b>3. Characteristics &amp; Specifications</b>	<b>7</b>
Recommended Operating Conditions	7
Analog Characteristics	7
Voltage Reference	8
Digital Characteristics	9
Switching Characteristics	10
Absolute Maximum Ratings	12
<b>4. Theory of Operation</b>	<b>13</b>
4.1 Digital Filters	13
4.2 Voltage and Current Measurements	13
4.3 Power Measurements	13
4.4 Linearity Performance	14
<b>5. Functional Description</b>	<b>15</b>
5.1 Analog Inputs	15
5.1.1 Voltage Channel	15
5.1.2 Current Channel	15
5.2 High-pass Filters	15
5.3 Performing Measurements	15
5.4 Energy Pulse Output	16
5.4.1 Normal Format	16
5.4.2 Alternate Pulse Format	17
5.4.3 Mechanical Counter Format	17
5.4.4 Stepper Motor Format	17
5.4.5 Pulse Output $\overline{E3}$	18
5.4.6 Anti-creep for the Pulse Outputs	18
5.4.7 Design Examples	18
5.5 Voltage Sag-detect Feature	19
5.6 On-chip Temperature Sensor	19
5.7 Voltage Reference	20
5.8 System Initialization	20
5.9 Power-down States	20
5.10 Oscillator Characteristics	20
5.11 Event Handler	20
5.11.1 Typical Interrupt Handler	20
5.12 Serial Port Overview	21
5.12.1 Serial Port Interface	21
5.13 Command Words	22

<b>6. Register Description</b>	<b>25</b>
6.1 Configuration Register	25
6.2 Current DC Offset Register and Voltage DC Offset Register	26
6.3 Current Gain Register and Voltage Gain Register	26
6.4 Cycle Count Register	26
6.5 PulseRateE <sub>1,2</sub> Register	27
6.6 Instantaneous Current, Voltage and Power Registers	27
6.7 Active (Real) Power Registers	27
6.8 I <sub>RMS</sub> , V <sub>RMS</sub> Registers	27
6.9 Power Offset Register	28
6.10 Status Register and Mask Register	28
6.11 Current AC Offset Register and Voltage AC Offset Register	29
6.12 PulseRateE <sub>3</sub> Register	30
6.13 Temperature Register	30
6.14 System Gain Register	30
6.15 Pulsewidth Register	30
6.16 Voltage Sag Duration Register	31
6.17 Voltage Sag Level Register	31
6.18 Control Register	31
6.19 Temperature Gain Register	32
6.20 Temperature Offset Register	32
6.21 Apparent Power Register	32
<b>7. System Calibration</b>	<b>33</b>
7.1 Channel Offset and Gain Calibration	33
7.1.1 Calibration Sequence	33
7.1.1.1 Duration of Calibration Sequence	33
7.1.2 Offset Calibration Sequence	33
7.1.2.1 DC Offset Calibration Sequence	33
7.1.2.2 AC Offset Calibration Sequence	34
7.1.3 Gain Calibration Sequence	34
7.1.3.1 AC Gain Calibration Sequence	34
7.1.3.2 DC Gain Calibration Sequence	35
7.1.4 Order of Calibration Sequences	35
7.2 Phase Compensation	35
7.3 Active Power Offset	35
<b>8. Auto-boot Mode Using E<sup>2</sup>PROM</b>	<b>36</b>
8.1 Auto-Boot Configuration	36
8.2 Auto-Boot Data for E <sup>2</sup> PROM	36
8.3 Suggested E <sup>2</sup> PROM Devices	36
<b>9. Basic Application Circuits</b>	<b>37</b>
<b>10. Package Dimensions</b>	<b>40</b>
<b>11. Revisions</b>	<b>41</b>

---

## LIST OF FIGURES

Figure 1. CS5461A Read and Write Timing Diagrams .....	11
Figure 2. Data Flow.....	13
Figure 3. Normal Format on pulse outputs $\overline{E1}$ and $\overline{E2}$ .....	16
Figure 4. Alternate Pulse Format on $\overline{E1}$ and $\overline{E2}$ .....	17
Figure 5. Mechanical Counter Format on $\overline{E1}$ and $\overline{E2}$ .....	17
Figure 6. Stepper Motor Format on $\overline{E1}$ and $\overline{E2}$ .....	18
Figure 7. Oscillator Connection.....	20
Figure 8. Calibration Data Flow .....	33
Figure 9. System Calibration of Offset. ....	33
Figure 10. System Calibration of Gain. ....	34
Figure 11. Example of AC Gain Calibration .....	34
Figure 12. Another Example of AC Gain Calibration .....	34
Figure 13. Typical Interface of E <sup>2</sup> PROM to CS5461A .....	36
Figure 14. Typical Connection Diagram (One-Phase 2-Wire, Direct Connect to Power Line)....	37
Figure 16. Typical Connection Diagram (One-Phase 3-Wire).....	38
Figure 15. Typical Connection Diagram (One-Phase 2-Wire, Isolated from Power Line).....	38
Figure 17. Typical Connection Diagram (One-Phase 3-Wire - No Neutral Available).....	39

## LIST OF TABLES

Table 1. Current Channel PGA Configuration .....	15
Table 2. $\overline{E1}$ and $\overline{E2}$ Pulse Output Format .....	16
Table 3. Interrupt Configuration .....	20

## 1. GENERAL DESCRIPTION

The CS5461A is a CMOS monolithic power measurement device with a computation engine and an energy-to-frequency pulse output. The CS5461A combines a programmable gain amplifier, two  $\Delta\Sigma$  analog-to-digital converters (ADCs), system calibration and a computation engine on a single chip.

The CS5461A is designed for power measurement applications and is optimized to interface to a current sense resistor or transformer for current measurement, and to a resistive divider or potential transformer for voltage measurement. The voltage and current channel provides programmable gains to accommodate various input levels from a multitude of sensing elements. With single +5 V supply on VA+/AGND, both of the CS5461A's input channels can accommodate common mode as well as signal levels between (AGND - 0.25 V) and VA+.

The CS5461A also is equipped with a computation engine that calculates  $I_{RMS}$ ,  $V_{RMS}$ , apparent power and active (real) power. To facilitate communication to a microprocessor, the CS5461A includes a simple three-wire serial interface which is SPI™ and Microwire™ compatible. The CS5461A provides three outputs for energy registration.  $\overline{E1}$  and  $\overline{E2}$  are designed to directly drive a mechanical counter or stepper motor, or interface to a microprocessor. The pulse output  $\overline{E3}$  is designed to assist with meter calibration.

## 2. PIN DESCRIPTION

Crystal Out	<b>XOUT</b>	1	24	<b>XIN</b>	Crystal In
CPU Clock Output	<b>CPUCLK</b>	2	23	<b>SDI</b>	Serial Data Input
Positive Digital Supply	<b>VD+</b>	3	22	<b>E2</b>	Energy Output 2
Digital Ground	<b>DGND</b>	4	21	<b>E1</b>	Energy Output 1
Serial Clock	<b>SCLK</b>	5	20	<b>INT</b>	Interrupt
Serial Data Output	<b>SDO</b>	6	19	<b>RESET</b>	Reset
Chip Select	<b>CS</b>	7	18	<b>E3</b>	High Frequency Energy Output
Mode Select	<b>MODE</b>	8	17	<b>PFMON</b>	Power Fail Monitor
Differential Voltage Input	<b>VIN+</b>	9	16	<b>IIN+</b>	Differential Current Input
Differential Voltage Input	<b>VIN-</b>	10	15	<b>IIN-</b>	Differential Current Input
Voltage Reference Output	<b>VREFOUT</b>	11	14	<b>VA+</b>	Positive Analog Supply
Voltage Reference Input	<b>VREFIN</b>	12	13	<b>AGND</b>	Analog Ground

### Clock Generator

<b>Crystal Out</b>	1,24	<b>XOUT, XIN</b> - The output and input of an inverting amplifier. Oscillation occurs when connected to a crystal, providing an on-chip system clock. Alternatively, an external clock can be supplied to the XIN pin to provide the system clock for the device.
<b>Crystal In</b>		
<b>CPU Clock Output</b>	2	<b>CPUCLK</b> - Output of on-chip oscillator which can drive one standard CMOS load.

### Control Pins and Serial Data I/O

<b>Serial Clock Input</b>	5	<b>SCLK</b> - A Schmitt Trigger input pin. Clocks data from the SDI pin into the receive buffer and out of the transmit buffer onto the SDO pin when $\overline{CS}$ is low.
<b>Serial Data Output</b>	6	<b>SDO</b> - Serial port data output pin. SDO is forced into a high impedance state when $\overline{CS}$ is high.
<b>Chip Select</b>	7	$\overline{CS}$ - Low, activates the serial port interface.
<b>Mode Select</b>	8	<b>MODE</b> - High, enables the "auto-boot" mode. The mode pin is pull-down by an internal resistor.
<b>High Frequency Energy Output</b>	18	$\overline{E3}$ - Active low pulses with an output frequency proportional to the active power. Used to assist in system calibration.
<b>Reset</b>	19	$\overline{RESET}$ - A Schmitt Trigger input pin. Low activates Reset, all internal registers (some of which drive output pins) are set to their default states.
<b>Interrupt</b>	20	$\overline{INT}$ - Low, indicates that an enabled event has occurred.
<b>Energy Output</b>	21,22	$\overline{E1}, \overline{E2}$ - Active low pulses with an output frequency proportional to the active power. Indicates if the measured energy is negative.
<b>Serial Data Input</b>	23	<b>SDI</b> - Serial port data input pin. Data will be input at a rate determined by SCLK.

### Analog Inputs/Outputs

<b>Differential Voltage Inputs</b>	9,10	<b>VIN+, VIN-</b> - Differential analog input pins for the voltage channel.
<b>Differential Current Inputs</b>	15,16	<b>IIN+, IIN-</b> - Differential analog input pins for the current channel.
<b>Voltage Reference Output</b>	11	<b>VREFOUT</b> - The on-chip voltage reference output. The voltage reference has a nominal magnitude of 2.5 V and is referenced to the AGND pin on the converter.
<b>Voltage Reference Input</b>	12	<b>VREFIN</b> - The input to this pin establishes the voltage reference for the on-chip modulator.

### Power Supply Connections

<b>Positive Digital Supply</b>	3	<b>VD+</b> - The positive digital supply.
<b>Digital Ground</b>	4	<b>DGND</b> - Digital Ground.
<b>Positive Analog Supply</b>	14	<b>VA+</b> - The positive analog supply.
<b>Analog Ground</b>	13	<b>AGND</b> - Analog ground.
<b>Power Fail Monitor</b>	17	<b>PFMON</b> - The power fail monitor pin monitors the analog supply. If PFMON's voltage threshold is tripped, a Low-Supply Detect (LSD) event is set in the status register.

### 3. CHARACTERISTICS & SPECIFICATIONS

#### RECOMMENDED OPERATING CONDITIONS

Parameter	Symbol	Min	Typ	Max	Unit
Positive Digital Power Supply	VD+	3.135	5.0	5.25	V
Positive Analog Power Supply	VA+	4.75	5.0	5.25	V
Voltage Reference	VREFIN	-	2.5	-	V
Specified Temperature Range	T <sub>A</sub>	-40	-	+85	°C

#### ANALOG CHARACTERISTICS

- Min / Max characteristics and specifications are guaranteed over all Operating Conditions.
- Typical characteristics and specifications are measured at nominal supply voltages and T<sub>A</sub> = 25 °C.
- VA+ = VD+ = 5 V ±5%; AGND = DGND = 0 V; VREFIN = +2.5 V. All voltages with respect to 0 V.
- MCLK = 4.096 MHz.

Parameter	Symbol	Min	Typ	Max	Unit	
<b>Linearity Performance</b>						
Active Power Accuracy (Note 1)	All Gain Ranges Input Range 0.1% - 100%	P <sub>Active</sub>	-	±0.1	-	%
Current RMS Accuracy (Note 1)	All Gain Ranges	I <sub>RMS</sub>	-	±0.1	-	%
	Input Range 1.0% - 100%					
	Input Range 0.3% - 1.0%					
	Input Range 0.1% - 0.3%					
Voltage RMS Accuracy (Note 1)	All Gain Ranges Input Range 5% - 100%	V <sub>RMS</sub>	-	±0.1	-	%
<b>Analog Inputs (Both Channels)</b>						
Common Mode Rejection	(DC, 50, 60 Hz)	CMRR	80	-	-	dB
Common Mode + Signal	All Gain Ranges		-0.25	-	VA+	V
<b>Analog Inputs (Current Channel)</b>						
Differential Input Range {(IIN+) - (IIN-)}	(Gain = 10)	IIN	0	500	-	mV <sub>P-P</sub>
	(Gain = 50)					
Total Harmonic Distortion	(Gain = 50)	THD	80	94	-	dB
Crosstalk with Voltage Channel at Full Scale	(50, 60 Hz)		-	-115	-	dB
Input Capacitance	(Gain = 10)	IC	-	32	-	pF
	(Gain = 50)					
Effective Input Impedance		EII	30	-	-	kΩ
Noise (Referred to Input)	(Gain = 10)	N <sub>I</sub>	-	-	22.5	μV <sub>rms</sub>
	(Gain = 50)					
Offset Drift (Without the high-pass filter)		OD	-	4.0	-	μV/°C
Gain Error	(Note 2)	GE	-	±0.4	-	%
<b>Analog Inputs (Voltage Channel)</b>						
Differential Input Range	{(VIN+) - (VIN-)}	VIN	0	500	-	mV <sub>P-P</sub>
Total Harmonic Distortion		THD	65	75	-	dB
Crosstalk with Current Channel at Full Scale	(50, 60 Hz)		-	-	-70	dB
Input Capacitance	All Gain Ranges	IC	-	0.2	-	pF
Effective Input Impedance		EII	2	-	-	MΩ
Noise (Referred to Input)		N <sub>V</sub>	-	-	140	μV <sub>rms</sub>
Offset Drift (Without the high-pass Filter)		OD	-	16.0	-	μV/°C
Gain Error	(Note 2)	GE	-	±3.0	-	%

**ANALOG CHARACTERISTICS** (Continued)

Parameter	Symbol	Min	Typ	Max	Unit
<b>Temperature Channel</b>					
Temperature Accuracy	T	-	±5	-	°C
<b>Power Supplies</b>					
Power Supply Currents (Active State)	I <sub>A+</sub>	-	1.3	1.75	mA
I <sub>D+</sub> (VA+ = VD+ = 5 V)	PSCD	-	2.9	3.5	mA
I <sub>D+</sub> (VA+ = 5 V, VD+ = 3.3 V)	PSCD	-	1.7	2.0	mA
Power Consumption	PC	-	21	26.25	mW
Active State (VA+ = VD+ = 5 V)		-	12	15.35	mW
Active State (VA+ = 5 V, VD+ = 3.3 V)		-	6.75	-	mW
Stand-By State		-	10	-	µW
Sleep State		-			
Power Supply Rejection Ratio (DC, 50 and 60 Hz)	PSRR	45	65	-	dB
Voltage Channel		70	75	-	dB
Current Channel					
PFMON Low-Voltage Trigger Threshold (Note 5)	PMLO	2.3	2.45	-	V
PFMON High-Voltage Power-On Trip Point (Note 6)	PMHI	-	2.55	2.7	V

1. Applies when the HPF option is enabled.
2. Applies before system calibration.
3. All outputs unloaded. All inputs CMOS level.
4. Definition for PSRR: VREFIN tied to VREFOUT, VA+ = VD+ = 5 V, a 150 mV (zero-to-peak) (60 Hz) sinewave is imposed onto the +5 V DC supply voltage at VA+ and VD+ pins. The "+" and "-" input pins of both input channels are shorted to AGND. Then the CS5461A is commanded to continuous conversion acquisition mode, and digital output data is collected for the channel under test. The (zero-to-peak) value of the digital sinusoidal output signal is determined, and this value is converted into the (zero-to-peak) value of the sinusoidal voltage (measured in mV) that would need to be applied at the channel's inputs, in order to cause the same digital sinusoidal output. This voltage is then defined as V<sub>eq</sub>. PSRR is then (in dB):

$$PSRR = 20 \cdot \log \left\{ \frac{150}{V_{eq}} \right\}$$

5. When voltage level on PFMON is sagging, and LSD bit is at 0, the voltage at which LSD bit is set to 1.
6. If the LSD bit has been set to 1 (because PFMON voltage fell below PMLO), this is the voltage level on PFMON at which the LSD bit can be permanently reset back to 0.

**VOLTAGE REFERENCE**

Parameter	Symbol	Min	Typ	Max	Unit
<b>Reference Output</b>					
Output Voltage	VREFOUT	+2.4	+2.5	+2.6	V
Temperature Coefficient (Note 7)	TC <sub>VREF</sub>	-	25	60	ppm/°C
Load Regulation (Note 8)	ΔV <sub>R</sub>	-	6	10	mV
<b>Reference Input</b>					
Input Voltage Range	VREFIN	+2.4	+2.5	+2.6	V
Input Capacitance		-	4	-	pF
Input CVF Current		-	25	-	nA

Notes: 7. The voltage at VREFOUT is measured across the temperature range. From these measurements the following formula is used to calculate the VREFOUT Temperature Coefficient:

$$TC_{VREF} = \left( \frac{VREFOUT_{MAX} - VREFOUT_{MIN}}{VREFOUT_{AVG}} \right) \left( \frac{1}{T_{A_{MAX}} - T_{A_{MIN}}} \right) \left( 1.0 \times 10^6 \right)$$

8. Specified at maximum recommended output of 1 µA, source or sink.



**DIGITAL CHARACTERISTICS**

- Min / Max characteristics and specifications are guaranteed over all Operating Conditions.
- Typical characteristics and specifications are measured at nominal supply voltages and TA = 25 °C.
- VA+ = VD+ = 5V ±5%; AGND = DGND = 0 V. All voltages with respect to 0 V.
- MCLK = 4.096 MHz.

Parameter	Symbol	Min	Typ	Max	Unit
<b>Master Clock Characteristics</b>					
Master Clock Frequency Internal Gate Oscillator (Note 10)	MCLK	2.5	4.096	20	MHz
Master Clock Duty Cycle		40	-	60	%
CPUCLK Duty Cycle (Note 11 and 12)		40		60	%
<b>Filter Characteristics</b>					
Phase Compensation Range (Voltage Channel, 60 Hz)		-2.8	-	+2.8	°
Input Sampling Rate DCLK = MCLK/K		-	DCLK/8	-	Hz
Digital Filter Output Word Rate (Both Channels)	OWR	-	DCLK/1024	-	Hz
High-pass Filter Corner Frequency -3 dB		-	0.5	-	Hz
Full Scale Calibration Range (Referred to Input) (Note 13)	FSCR	25	-	100	%F.S.
Channel-to-channel Time-shift Error (Note 14)			1.0		µs
<b>Input/Output Characteristics</b>					
High-level Input Voltage All Pins Except XIN and SCLK and $\overline{\text{RESET}}$	$V_{IH}$	0.6 VD+	-	-	V
XIN		(VD+) - 0.5	-	-	V
SCLK and $\overline{\text{RESET}}$		0.8 VD+	-	-	V
Low-level Input Voltage (VD = 5 V) All Pins Except XIN and SCLK and $\overline{\text{RESET}}$	$V_{IL}$	-	-	0.8	V
XIN		-	-	1.5	V
SCLK and $\overline{\text{RESET}}$		-	-	0.2 VD+	V
Low-level Input Voltage (VD = 3.3 V) All Pins Except XIN and SCLK and $\overline{\text{RESET}}$	$V_{IL}$	-	-	0.48	V
XIN		-	-	0.3	V
SCLK and $\overline{\text{RESET}}$		-	-	0.2 VD+	V
High-level Output Voltage I <sub>out</sub> = +5 mA	V <sub>OH</sub>	(VD+) - 1.0	-	-	V
Low-level Output Voltage I <sub>out</sub> = -5 mA	V <sub>OL</sub>	-	-	0.4	V
Input Leakage Current (Note 15)	I <sub>in</sub>	-	±1	±10	µA
3-state Leakage Current	I <sub>OZ</sub>	-	-	±10	µA
Digital Output Pin Capacitance	C <sub>out</sub>	-	5	-	pF

- Notes:
9. All measurements performed under static conditions.
  10. If a crystal is used, then XIN frequency must remain between 2.5 MHz - 5.0 MHz. If an external oscillator is used, XIN frequency range is 2.5 MHz - 20 MHz.
  11. If external MCLK is used, then the duty cycle must be between 45% and 55% to maintain this specification.
  12. The frequency of CPUCLK is equal to MCLK.
  13. The minimum FSCR is limited by the maximum allowed gain register value. The maximum FSCR is limited by the full-scale signal applied to the channel input.
  14. Configuration Register bits PC[6:0] are set to "0000000".
  15. The MODE pin is pull-down by an internal resistor.

**SWITCHING CHARACTERISTICS**

- Min / Max characteristics and specifications are guaranteed over all Operating Conditions.
- Typical characteristics and specifications are measured at nominal supply voltages and TA = 25 °C.
- VA+ = 5 V ±5% VD+ = 3.3 V ±5% or 5 V ±5%; AGND = DGND = 0 V. All voltages with respect to 0 V.
- Logic Levels: Logic 0 = 0 V, Logic 1 = VD+.

Parameter	Symbol	Min	Typ	Max	Unit	
Rise Times (Note 16)	Any Digital Input Except SCLK	$t_{rise}$	-	-	1.0	µs
	SCLK	-	-	100	µs	
	Any Digital Output	-	50	-	ns	
Fall Times (Note 16)	Any Digital Input Except SCLK	$t_{fall}$	-	-	1.0	µs
	SCLK	-	-	100	µs	
	Any Digital Output	-	50	-	ns	
<b>Start-up</b>						
Oscillator Start-Up Time	XTAL = 4.096 MHz (Note 17)	$t_{ost}$	-	60	-	ms
<b>Serial Port Timing</b>						
Serial Clock Frequency	SCLK	-	-	2	MHz	
Serial Clock	Pulse Width High	$t_1$	200	-	-	ns
	Pulse Width Low	$t_2$	200	-	-	ns
<b>SDI Timing</b>						
$\overline{CS}$ Falling to SCLK Rising	$t_3$	50	-	-	ns	
Data Set-up Time Prior to SCLK Rising	$t_4$	50	-	-	ns	
Data Hold Time After SCLK Rising	$t_5$	100	-	-	ns	
<b>SDO Timing</b>						
$\overline{CS}$ Falling to SDI Driving	$t_6$	-	20	50	ns	
SCLK Falling to New Data Bit (hold time)	$t_7$	-	20	50	ns	
$\overline{CS}$ Rising to SDO Hi-Z	$t_8$	-	20	50	ns	
<b>Auto-Boot Timing</b>						
Serial Clock	Pulse Width Low	$t_9$	-	8	MCLK	
	Pulse Width High	$t_{10}$	-	8	MCLK	
MODE setup time to $\overline{RESET}$ Rising	$t_{11}$	50	-	-	ns	
$\overline{RESET}$ rising to $\overline{CS}$ falling	$t_{12}$	48	-	-	MCLK	
$\overline{CS}$ falling to SCLK rising	$t_{13}$	100	8	-	MCLK	
SCLK falling to $\overline{CS}$ rising	$t_{14}$	-	16	-	MCLK	
$\overline{CS}$ rising to driving MODE low (to end auto-boot sequence).	$t_{15}$	50	-	-	ns	
SDO guaranteed setup time to SCLK rising	$t_{16}$	100	-	-	ns	

Notes: 16. Specified using 10% and 90% points on wave-form of interest. Output loaded with 50 pF.

17. Oscillator start-up time varies with crystal parameters. This specification does not apply when using an external clock source.

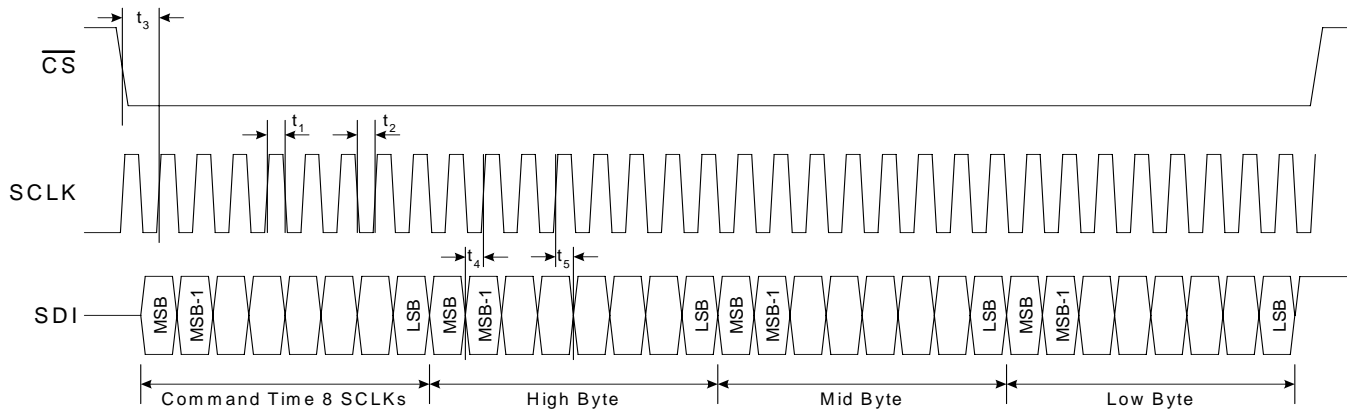

**SDI Write Timing (Not to Scale)**

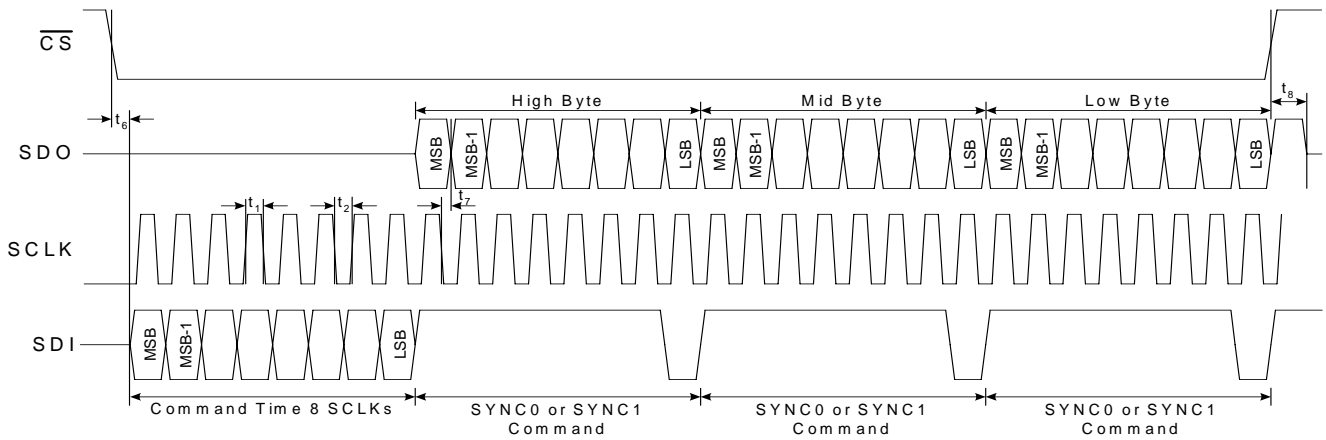

**SDO Read Timing (Not to Scale)**

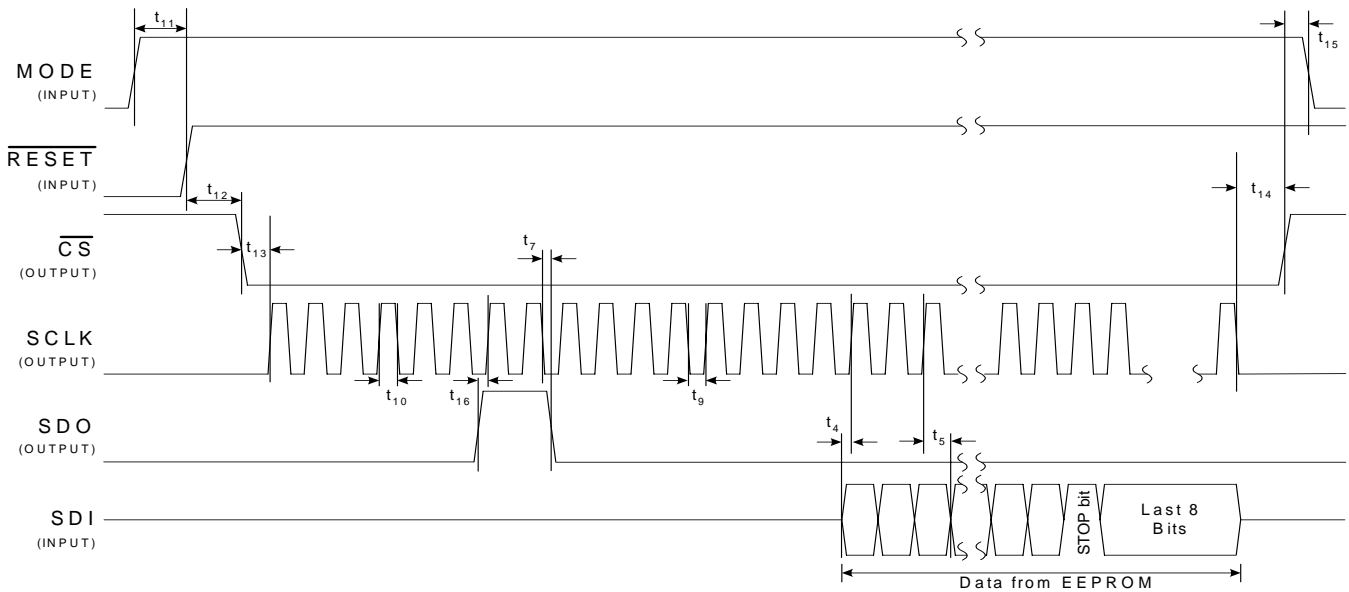

**Auto-Boot Sequence Timing (Not to Scale)**

**Figure 1. CS5461A Read and Write Timing Diagrams**

**ABSOLUTE MAXIMUM RATINGS**

WARNING: Operation at or beyond these limits may result in permanent damage to the device.

Normal operation is not guaranteed at these extremes.

Parameter	Symbol	Min	Typ	Max	Unit
DC Power Supplies (Notes 18 and 19)					
Positive Digital	VD+	-0.3	-	+6.0	V
Positive Analog	VA+	-0.3	-	+6.0	V
Input Current, Any Pin Except Supplies (Notes 20, 21, 22)	I <sub>IN</sub>	-	-	±10	mA
Output Current, Any Pin Except VREFOUT	I <sub>OUT</sub>	-	-	100	mA
Power Dissipation (Note 23)	P <sub>D</sub>	-	-	500	mW
Analog Input Voltage All Analog Pins	V <sub>INA</sub>	- 0.3	-	(VA+) + 0.3	V
Digital Input Voltage All Digital Pins	V <sub>IND</sub>	-0.3	-	(VD+) + 0.3	V
Ambient Operating Temperature	T <sub>A</sub>	-40	-	85	°C
Storage Temperature	T <sub>stg</sub>	-65	-	150	°C

- Notes:
18. VA+ and AGND must satisfy  $\{(VA+) - (AGND)\} \leq + 6.0 V$ .
  19. VD+ and AGND must satisfy  $\{(VD+) - (AGND)\} \leq + 6.0 V$ .
  20. Applies to all pins including continuous over-voltage conditions at the analog input pins.
  21. Transient current of up to 100 mA will not cause SCR latch-up.
  22. Maximum DC input current for a power supply pin is ±50 mA.
  23. Total power dissipation, including all input currents and output currents.

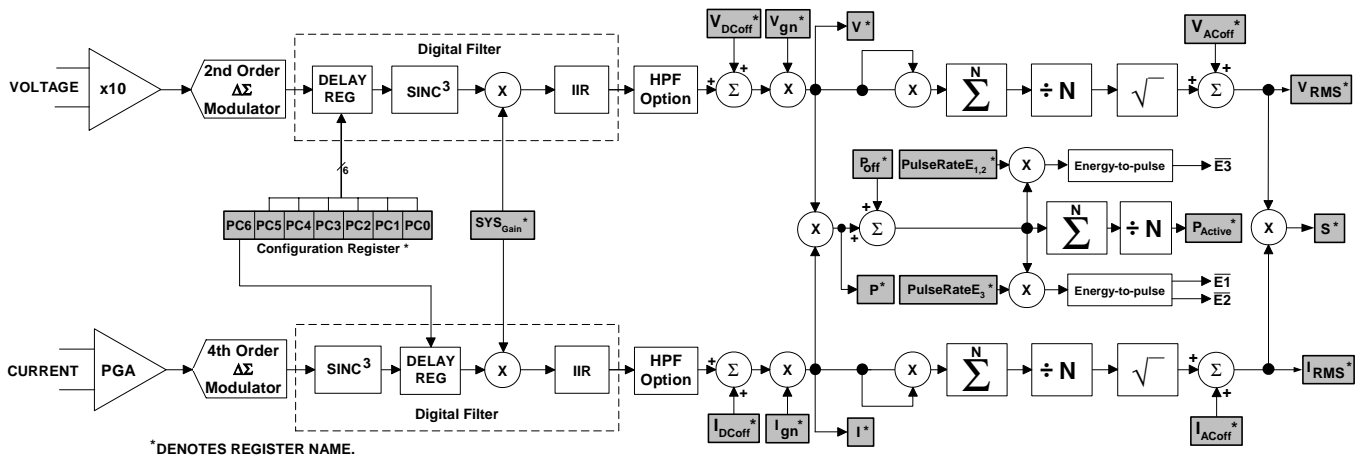
**Figure 2. Data Flow.**

## 4. THEORY OF OPERATION

The CS5461A is a dual-channel analog-to-digital converter (ADC) followed by a computation engine that performs power calculations and energy-to-pulse conversion. The flow diagram for the two data paths is depicted in Figure 2. The analog inputs are structured with two dedicated channels, voltage and current, then optimized to simplify interfacing to sensing elements.

The voltage-sensing element introduces a voltage waveform on the voltage channel input  $V_{IN\pm}$  and is subject to a gain of 10x. A second-order, delta-sigma modulator samples the amplified signal for digitization.

Simultaneously, the current-sensing element introduces a voltage waveform on the current channel input  $I_{IN\pm}$  and is subject to the two selectable gains of the programmable gain amplifier (PGA). The amplified signal is sampled by a fourth-order, delta-sigma modulator for digitization. Both converters sample at a rate of  $MCLK/8$ , the over-sampling provides a wide dynamic range and simplified anti-alias filter design.

### 4.1 Digital Filters

The decimating digital filters on both channels are  $Sinc^3$  filters followed by 4th-order, IIR filters. The single-bit data is passed to the low-pass decimation filter and output at a fixed word rate. The output word is passed to the IIR filter to compensate for the magnitude roll-off of the low-pass filtering operation.

An optional digital High-pass Filter (HPF in Figure 2) removes any DC component from the selected signal path. By removing the DC component from the voltage and/or the current channel, any DC content will also be removed from the calculated active power as well. With both HPFs enabled the DC component will be removed from the calculated  $V_{RMS}$  and  $I_{RMS}$  as well as the apparent power.

### 4.2 Voltage and Current Measurements

The digital filter output word is then subject to a DC-off-set adjustment and a gain calibration (see Section 7. System Calibration). The calibrated measurement is available to the user by reading the instantaneous voltage and current registers

The Root Mean Square (RMS) calculations are performed on  $N$  (where  $N$  is the cycle count) instantaneous voltage and current samples,  $V_n$  and  $I_n$  respectively, using the formula:

$$I_{RMS} = \sqrt{\frac{\sum_{n=0}^{N-1} I_n^2}{N}}$$

and likewise for  $V_{RMS}$ , using  $V_n$ .  $I_{RMS}$  and  $V_{RMS}$  are accessible by register reads, which are updated once every cycle count (referred to as a computational cycle).

### 4.3 Power Measurements

The instantaneous voltage and current data samples are multiplied together to obtain the instantaneous power (see Figure 2). The product is then averaged over  $N$  conversions to compute the active-power value used to drive energy pulse outputs  $\bar{E1}$ ,  $\bar{E2}$  and  $\bar{E3}$ . Output  $\bar{E3}$  provides a uniform pulse stream that is proportional to the active power and is designed for system calibration.

The active power can be multiplied by the time duration of the computation cycle, to generate a value for the accumulated active energy over the last computation cycle.

The apparent power is the combination of the active power and reactive power, without reference to an impedance-phase angle, and is calculated by the CS5461A using the following formula:

$$S = V_{\text{RMS}} \times I_{\text{RMS}}$$

The apparent power is registered once every computation cycle.

#### 4.4 Linearity Performance

The linearity of the  $V_{\text{RMS}}$ ,  $I_{\text{RMS}}$ , and active power measurements (before calibration) will be within  $\pm 0.1\%$  of reading over the ranges specified, with respect to the in-

put voltage levels required to cause full-scale readings in the  $I_{\text{rms}}$  and  $V_{\text{rms}}$  registers. Refer to Linearity Performance Specifications on page 7.

Until the CS5461A is calibrated (see Section 7. System Calibration) the *accuracy* of the CS5461A (with respect to a reference line-voltage and line-current level on the power mains) is not guaranteed to within  $\pm 0.1\%$ . The accuracy of the internal calculations can often be improved by selecting a value for the Cycle Count Register that will cause the time duration of one computation cycle to be equal (or very close to) a whole-number of power-line cycles (and N must be greater than or equal to 4000).

## 5. FUNCTIONAL DESCRIPTION

### 5.1 Analog Inputs

The CS5461A is equipped with two fully differential input channels. The inputs  $V_{IN\pm}$  and  $I_{IN\pm}$  are designated as the voltage and current channel inputs, respectively. The full-scale differential input voltage for the current and voltage channel is  $\pm 250$  mV<sub>P</sub>.

#### 5.1.1 Voltage Channel

The output of the line-voltage resistive divider or transformer is connected to the  $V_{IN+}$  and  $V_{IN-}$  input pins of the CS5461A. The voltage channel is equipped with a 10x, fixed-gain amplifier. The full-scale signal level that can be applied to the voltage channel is  $\pm 250$  mV. If the input signal is a sine wave the maximum RMS voltage at a gain 10x is:

$$\frac{250\text{mV}_P}{\sqrt{2}} \cong 176.78\text{mV}_{\text{RMS}}$$

which is approximately 70.7% of maximum peak voltage. The voltage channel is also equipped with a *Voltage Gain Register*, allowing for an additional programmable gain of up to 4x

#### 5.1.2 Current Channel

The output of the current-sense resistor or transformer is connected to the  $I_{IN+}$  and  $I_{IN-}$  input pins of the CS5461A. To accommodate different current-sensing elements the current channel incorporates a Programmable Gain Amplifier (PGA) with two programmable input gains. *Configuration Register* bit  $I_{\text{gain}}$  (See Table 1) defines the two gain selections and corresponding maximum input-signal level.

$I_{\text{gain}}$	Maximum Input Range	
0	$\pm 250$ mV	10x
1	$\pm 50$ mV	50x

**Table 1. Current Channel PGA Configuration**

For example if  $I_{\text{gain}}=0$ , the current channel's PGA gain is set to 10x. If the input signals are pure sinusoids with zero phase shift, the maximum peak differential signal on the current or voltage channel is  $\pm 250$  mV<sub>P</sub>. The input-signal levels are approximately 70.7% of maximum peak voltage producing a full-scale energy pulse registration equal to 50% of absolute maximum energy pulse registration. This will be discussed further in Section 5.4 Energy Pulse Output.

The Current Gain Register also allows for an additional programmable gain of up to 4x. If an additional gain is

applied to the voltage and/or current channel, the maximum input range should be adjusted accordingly.

### 5.2 High-pass Filters

By removing the offset from either channel, no error component will be generated at DC when computing the active power. By removing the offset from both channels, no error component will be generated at DC when computing  $V_{\text{RMS}}$ ,  $I_{\text{RMS}}$ , and apparent power. *Configuration Register* bits VHPF and IHPF engage the HPF in the voltage and current channel respectively.

### 5.3 Performing Measurements

The CS5461A performs measurements of instantaneous voltage ( $V_n$ ), current ( $I_n$ ), and power ( $P_n$ ) at an Output Word Rate (OWR) of

$$\text{OWR} = \frac{(\text{MCLK}/K)}{1024}$$

where K is the clock divider setting in the *Configuration Register*.

The RMS voltage ( $V_{\text{RMS}}$ ), RMS current ( $I_{\text{RMS}}$ ), and active power ( $P_{\text{Active}}$ ) are computed using N instantaneous samples of  $V_n$ ,  $I_n$  and  $P_n$  respectively, where N is the value in the *Cycle Count Register* and is referred to as a "computation cycle". The apparent power (S) is the product of  $V_{\text{RMS}}$  and  $I_{\text{RMS}}$ . A computation cycle is derived from the master clock (MCLK), with frequency:

$$\text{Computation Cycle} = \frac{\text{OWR}}{N}$$

Under default conditions  $K = 1$ ,  $N = 4000$  and  $\text{MCLK} = 4.096$  MHz, the  $\text{OWR} = 4000$  Hz, whereas the  $\text{Computation Cycle} = 1$  Hz.

All measurements are available as a percentage of full scale. The format for *signed* registers is a two's complement, normalized value between -1 and +1. The format for *unsigned* registers is a normalized value between 0 and 1. A register value of

$$\frac{(2^{23} - 1)}{2^{23}} = 0.99999988$$

represents the maximum possible value.

At each instantaneous measurement, the CRDY bit will be asserted in the *Status Register*, and the INT pin will become active if the CRDY bit is unmasked in the *Mask Register*. At the end of each computation cycle, the DRDY bit will be asserted in the *Status Register*, and the INT pin will become active if the DRDY bit is un-



masked in the *Mask Register*. When these bits are asserted, they must be cleared by the user before they can be asserted again.

If the *Cycle Count Register* value (N) is set to 1, all output calculations are instantaneous, and DRDY, like CRDY, will indicate when instantaneous measurements are finished.

### 5.4 Energy Pulse Output

The CS5461A provides three output pins for energy registration. The E1 and E2 pins provide a simple interface which energy can be registered. These pins are designed to directly connect to a stepper motor or electro-mechanical counter. E1 and E2 pins can be set to one of four pulse output formats, Normal, Alternate, Stepper Motor or Mechanical Counter. Table 2 defines the pulse output format, which is controlled by bits ALT in the *Configuration Register*, and MECH and STEP in the *Control Register*.

ALT	STEP	MECH	FORMAT
0	0	0	Normal
0	X	1	Mechanical Counter
0	1	0	Stepper Motor
1	X	1	Alternate Pulse

**Table 2. E1 and E2 Pulse Output Format**

The E3 pin is designated for system calibration, the pulse rate can be selected to reach a frequency of 512 kHz.

The pulse output frequency of E1 and E2 is directly proportional to the active power calculated from the input signals. To calculate the output frequency on E1 and E2, the following transfer function can be utilized:

$$FREQ_E = \frac{VIN \times VGAIN \times IIN \times IGAIN \times PF \times PulseRate_{E_{1,2}}}{VREFIN^2}$$

FREQ<sub>E</sub> = Average frequency of E1 and E2 pulses [Hz]  
 VIN = rms voltage across VIN+ and VIN- [V]  
 VGAIN = Voltage channel gain  
 IIN = rms voltage across IIN+ and IIN- [V]  
 IGAIN = Current channel gain  
 PF = Power Factor  
 PulseRate<sub>E<sub>1,2</sub></sub> = Maximum frequency on E1 and E2 [Hz]  
 VREFIN = Voltage at VREFIN pin [V]

With MCLK = 4.096 MHz, PF = 1 and default settings, the pulses will have an average frequency equal to the frequency setting in the *PulseRateE<sub>1,2</sub> Register* when the input signals applied to the voltage and current channels cause full-scale readings in the instantaneous voltage and current registers. When MCLK/K is not equal to 4.096 MHz, the user should scale the *PulseRateE<sub>1,2</sub> Register* by a factor of 4.096 MHz/(MCLK/K) to get the actual pulse rate output.

#### 5.4.1 Normal Format

The Normal format is the default. Figure 3 illustrates the output format on pins E1 and E2. The E1 pin is active-low pulses with an output frequency proportional to the active power. The E2 pin is the energy direction indicator. Positive energy is represented by a pulse on the E1 pin while the E2 remains high. Negative energy is represented by synchronous pulses on both the E1 pin and the E2 pin.

The *PulseRateE<sub>1,2</sub> Register* defines the average frequency on output pin E1, when full-scale input signals are applied to the voltage and current channels. The maximum pulse frequency from the E1 pin is

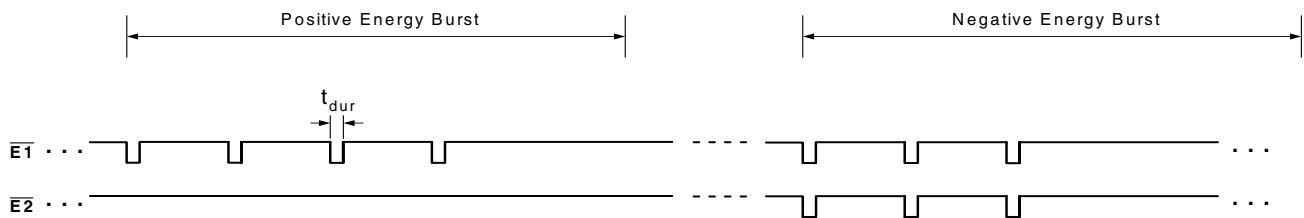

**Figure 3. Normal Format on pulse outputs E1 and E2**



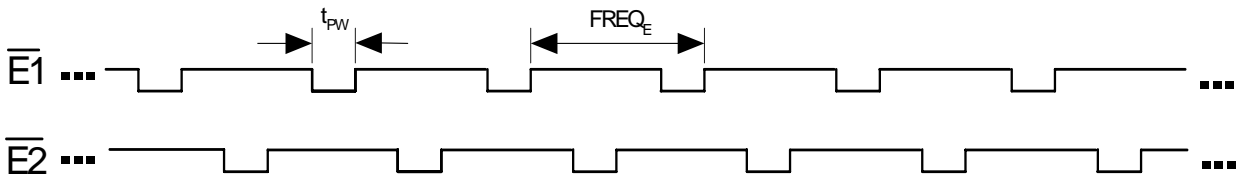

**Figure 4. Alternate Pulse Format on  $\overline{E1}$  and  $\overline{E2}$**

(MCLK/K)/16. The pulse duration ( $t_{dur}$ ) is an integer multiple of MCLK cycles, approximately equal to:

$$t_{dur}(\text{sec}) \cong \frac{1}{\text{PulseRateE}_{1,2} \times 8}$$

The maximum pulse duration ( $t_{dur}$ ) is determined by the sampling rate and the minimum is defined by the maximum pulse frequency. The  $t_{dur}$  limits are:

$$\frac{1}{(\text{MCLK/K})/16 \times 8} < t_{dur}(\text{sec}) < \frac{1}{(\text{MCLK/K})/1024 \times 8}$$

The *Pulse Width Register* (PW) does not affect the normal format.

### 5.4.2 Alternate Pulse Format

Setting bits MECH = 1 and STEP = 0 in the *Control Register* and ALT = 1 in the *Configuration Register* configures the  $\overline{E1}$  and  $\overline{E2}$  pins for alternating pulse output (see Figure 4). Each pin produces alternating active low pulses with a pulse duration ( $t_{PW}$ ) defined by the *Pulse Width Register* (PW):

$$t_{PW}(\text{ms}) = \frac{\text{PW}}{(\text{MCLK/K})/1024}$$

If MCLK = 4.096 MHz, K = 1, and PW = 1 then  $t_{PW} = 0.25$  ms. To insure that pulses occur on the  $\overline{E1}$

and  $\overline{E2}$  output pins when full-scale input signals are applied to the voltage and current channels, then:

$$\text{PulseRateE}_{1,2} < \frac{1}{t_{PW}}$$

The pulse frequency ( $\text{FREQ}_E$ ) is determined by the *PulseRateE<sub>1,2</sub> Register* and can be calculated using the transfer function. The energy direction is not defined in alternate pulse format.

### 5.4.3 Mechanical Counter Format

Setting bits MECH = 1 and STEP = 0 in the *Control Register* and bit ALT = 0 in the *Configuration Register* enables E1 and E2 for mechanical counters and similar discrete counting instruments. When energy is negative, pulses appear on  $\overline{E2}$  (see Figure 5). When energy is positive, the pulses appear on  $\overline{E1}$ . The pulse width is defined by the *Pulsewidth Register* and will limit the output pulse frequency ( $\text{FREQ}_E$ ). By default PW = 512 samples, if MCLK = 4.096 MHz and K = 1 then  $t_{PW} = 128$  ms. To ensure that pulses will occur, the *PulseRateE<sub>1,2</sub> Register* must be set to an appropriate value.

### 5.4.4 Stepper Motor Format

Setting bits STEP = 1 and MECH = 0 in the *Control Register* and bit ALT = 0 in the *Configuration Register* configures the  $\overline{E1}$  and  $\overline{E2}$  pins for stepper motor format. When the accumulated active power equals the defined

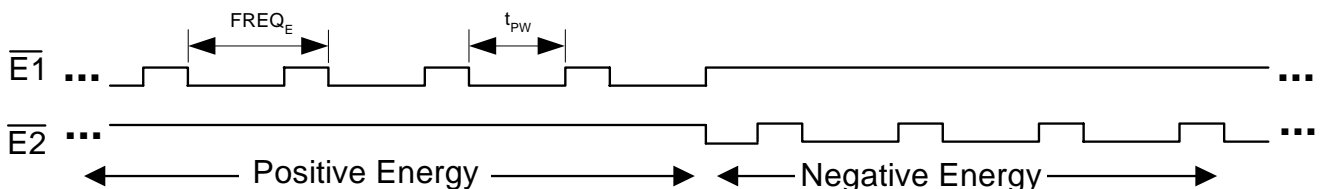

**Figure 5. Mechanical Counter Format on  $\overline{E1}$  and  $\overline{E2}$**

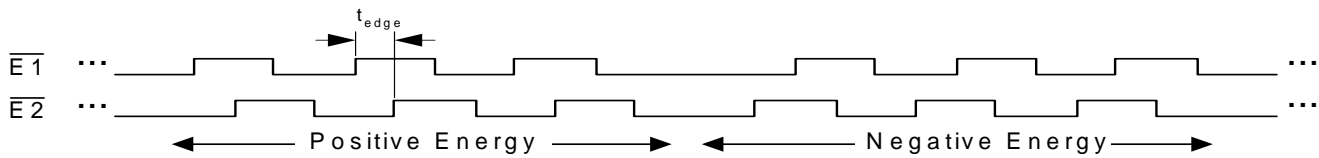

**Figure 6. Stepper Motor Format on  $\overline{E1}$  and  $\overline{E2}$**

energy level, the energy output pins ( $\overline{E1}$  and  $\overline{E2}$ ) alternate changing states (see Figure 6). The duration ( $t_{edge}$ ) between the alternating states is defined by the transfer function:

$$t_{edge}(\text{sec}) = \frac{1}{\text{FREQ}_E}$$

The direction the motor will rotate is determined by the order of the state changes. When energy is positive,  $\overline{E1}$  will lead  $\overline{E2}$ . When energy is negative,  $\overline{E2}$  will lead  $\overline{E1}$ . The *Pulse Width Register (PW)* does not affect the stepper motor format.

### 5.4.5 Pulse Output $\overline{E3}$

The pulse output  $\overline{E3}$  is designed to assist with meter calibration. The pulse-output frequency of  $\overline{E3}$  is directly proportional to the active power calculated from the input signals.  $\overline{E3}$  pulse frequency is derived using a similar transfer function as  $\overline{E1}$ , but is set by the value in the *PulseRate $E_3$  Register*.

The  $\overline{E3}$  pin outputs negative and positive energy, but has no energy direction indicator.

### 5.4.6 Anti-creep for the Pulse Outputs

Anti-creep allows the measurement element to maintain an energy level, such that when the magnitude of the accumulated active power is below this level, no energy pulses are output. Anti-creep is enabled by setting bit FAC in the *Control Register* for  $\overline{E3}$  and bit EAC in the *Control Register* for  $\overline{E1}$  and  $\overline{E2}$ .

For low-frequency pulse output formats (i.e. mechanical counter and stepper motor formats), the active power is accumulated over time. When a designated energy level is reached (determined by the Transfer Function) a pulse is generated on  $\overline{E1}$  and/or  $\overline{E2}$ . If active power with alternating polarity occurs during the accumulation period (e.g. random noise at zero power levels), the accuracy of the registered energy will be maintained.

For high-frequency pulse output formats (i.e. normal and alternate pulse formats), the active power is accumulated over time until a  $\pm 8x$  buffer is defined. Then, when the designated energy level is reached a pulse is

generated on  $\overline{E1}$  and/or  $\overline{E2}$ . For pulse outputs with high frequencies and power levels close to zero, the extended buffer prevents random noise from being registered as active energy.

### 5.4.7 Design Examples

#### EXAMPLE #1:

The maximum rated levels for a power line meter are 250 V rms and 20 A rms. The required number of pulses-per-second on  $\overline{E1}$  is 100 pulses-per-second (100 Hz), when the levels on the power line are 220 V rms and 15 A rms.

With a 10x gain on the voltage and current channel the maximum input signal is 250 mV<sub>P</sub> (see 5.1 Analog Inputs on page 15). To prevent from over-driving the channel inputs, the maximum rated rms input levels will register 0.6 in V<sub>RMS</sub> and I<sub>RMS</sub> by design. Therefore the voltage level at the channel inputs will be 150 mV rms when the maximum rated levels on the power lines are 250 V rms and 20 A rms.

Solving for PulseRate $E_{1,2}$  using the transfer function:

$$\text{PulseRate}_{E_{1,2}} = \frac{\text{FREQ}_E \times \text{VREFIN}^2}{\text{VIN} \times \text{VGAIN} \times \text{IIN} \times \text{PF}}$$

Therefore with PF = 1 and

$$\text{VIN} = 220\text{V} \times ((150\text{mV}) / (250\text{V})) = 132\text{mV}$$

$$\text{IIN} = 15\text{A} \times ((150\text{mV}) / (20\text{A})) = 112.5\text{mV}$$

the *PulseRate $E_{1,2}$  Register* is set to:

$$\text{PulseRate}_E = \frac{100 \times 2.5^2}{0.132 \times 10 \times 0.1125 \times 10} = 420.8754\text{Hz}$$

#### EXAMPLE #2:

The required number of pulses per unit energy present on  $\overline{E1}$  is specified to be 500 pulses-per-kWhr, given that the line voltage is 250 Vrms and the line current is 20 Arms. In such a situation, the stated line voltage and current do not determine the appropriate PulseRate $E_{1,2}$  setting. To achieve full-scale readings in the instanta-

neous voltage and current registers a 250 mV, DC-level signal is applied to the channel inputs.

As in example #1, the voltage and current channel gains are 10x, and the voltage level at the channel inputs will be 150 mV rms when the levels on the power lines are 250 V rms and 20 A rms. In order to achieve 500 pulse-per-kW Hr per unit-energy, the *PulseRateE<sub>1,2</sub> Register* setting is determined using the following equation:

$$\text{PulseRateE}_{1,2} = \frac{500 \text{ pulses}}{\text{kWhr}} \times \frac{1 \text{ Hr}}{3600 \text{ s}} \times \frac{1 \text{ kW}}{1000 \text{ W}} \times \frac{250 \text{ mV}}{\left(\frac{150 \text{ mV}}{250 \text{ V}}\right)} \times \frac{250 \text{ mV}}{\left(\frac{150 \text{ mV}}{20 \text{ A}}\right)}$$

Therefore *PulseRateE<sub>1,2</sub> Register* is approximately 1.929 Hz. *PulseRateE<sub>1,2</sub> Register* cannot be set to a frequency of exactly 1.929 Hz. The closest setting is 0x00003E = 1.9375 Hz.

To improve the accuracy, either gain register can be programmed to correct for the round-off error. This value would be calculated as

$$\text{Vgn or Ign} = \frac{\text{PulseRateE}}{1.929} \cong 1.00441 = 0x404830$$

If (MCLK/K) is not equal to 4.096 MHz, the *PulseRateE<sub>1,2</sub> Register* must be scaled by a correction factor of:

$$\frac{4.096 \text{ MHz}}{\text{(MCLK/K)}} \times \text{PulseRateE}_{1,2}$$

Therefore if (MCLK/K) = 3.05856 MHz the value of *PulseRateE<sub>1,2</sub> Register* is

$$\text{PulseRateE}_{1,2} = \frac{4.096}{3.05856} \times 1.929 \text{ Hz} \cong 2.583 \text{ Hz}$$

## 5.5 Voltage Sag-detect Feature

Status bit VSAG in the *Status Register*, indicates a voltage sag occurred in the power line voltage. For a voltage sag condition to be identified, the absolute value of the instantaneous voltage must be less than the voltage sag level for more than half of the voltage sag duration.

To activate Voltage Sag-detect, a voltage sag level must be specified in the *Voltage Sag Level Register* (VSAGLevel), and a voltage sag duration must be specified in the *Voltage Sag Duration Register* (VSAGDuration). Voltage sag duration is specified in terms of ADC cycles.

## 5.6 On-chip Temperature Sensor

The on-chip temperature sensor is designed to assist in characterizing the measurement element over a desired temperature range. Once a temperature characteriza-

tion is performed, the temperature sensor can then be utilized to assist in compensating for temperature drift.

Temperature measurements are performed during continuous conversions and stored in the *Temperature Register*. The *Temperature Register* (T) default is Celsius scale (°C). The *Temperature Gain Register* (T<sub>gain</sub>) and *Temperature Offset Register* (T<sub>off</sub>) are constant values allowing for temperature scale conversions.

The temperature update rate is a function of the number of ADC samples. With MCLK = 4.096 MHz and K = 1 the update rate is:

$$\frac{2240 \text{ samples}}{\text{(MCLK/K)/1024}} = 0.56 \text{ sec}$$

The cycle count must be set to a value greater than one. Status bit TUP in the *Status Register*, indicates when the *Temperature Register* is updated.

The *Temperature Offset Register* sets the zero-degree measurement. To improve temperature measurement accuracy, the zero-degree offset should be adjusted after the CS5461A is initialized. Temperature offset calibration is achieved by adjusting the *Temperature Offset Register* (T<sub>off</sub>) by the differential temperature (ΔT) measured from a calibrated digital thermometer and the CS5461A temperature sensor. A one degree adjustment to the *Temperature Register* (T) is achieved by adding 2.737649x10<sup>-4</sup> to the *Temperature Offset Register* (T<sub>off</sub>). Therefore,

$$T_{\text{off}} = T_{\text{off}} + (\Delta T \times 2.737649 \cdot 10^{-4})$$

if T<sub>off</sub> = -0.09104831 (default) and ΔT = -7.0 (°C), then

$$T_{\text{off}} = -0.09104831 + (-7.0 \times 2.737649 \cdot 10^{-4}) = -0.09296466$$

or 0xF419BC (2's compliment notation) is stored in the *Temperature Offset Register* (T<sub>off</sub>).

To convert the *Temperature Register* (T) from a Celsius scale (°C) to a Fahrenheit scale (°F) utilize the formula

$$^{\circ}\text{F} = \frac{9}{5} (^{\circ}\text{C} + 17.7778)$$

Applying the above relationship to the CS5461A temperature measurement algorithm

$$T(^{\circ}\text{F}) = \left(\frac{9}{5} \times T_{\text{gain}}\right) [T(^{\circ}\text{C}) + (T_{\text{off}} + (17.7778 \times 2.737649 \cdot 10^{-4}))]$$

If T<sub>off</sub> = -0.09296466 and T<sub>gain</sub> = 23.799 (default) for a Celsius scale, then the modified values are T<sub>off</sub> = -0.08809772 (0xF4B937) and T<sub>gain</sub> = 42.8382 (0x55AD29) for a Fahrenheit scale.

## 5.7 Voltage Reference

The CS5461A is specified for operation with a +2.5 V reference between the VREFIN and AGND pins. To utilize the on-chip 2.5 V reference, connect the VREFOUT pin to the VREFIN pin of the device. The VREFIN can be used to connect external filtering and/or references.

## 5.8 System Initialization

Upon powering up, the digital circuitry is held in reset until the analog voltage reaches 4.0 V. At that time, an eight-XIN-clock-period delay is enabled to allow the oscillator to stabilize. The CS5461A will then initialize.

A hardware reset is initiated when the  $\overline{\text{RESET}}$  pin is asserted with a minimum pulse width of 50 ns. The  $\overline{\text{RESET}}$  signal is asynchronous, with a Schmitt Trigger input. Once the  $\overline{\text{RESET}}$  pin is de-asserted, an eight-XIN-clock-period delay is enabled.

A software reset is initiated by writing the command word 0x80. After a hardware or software reset, the internal registers (some of which drive output pins) will be reset to their *default* values. Status bit DRDY in the *Status Register*, indicates the CS5461A is in its *active* state and ready to receive commands.

## 5.9 Power-down States

The CS5461A has two power-down states, stand-by and sleep. In the stand-by state all circuitry except the analog and digital clock generators is turned off. To return the device to active state the serial port must be initialized and a Power-up command sent to the device.

In sleep state all circuitry except the digital clock generator and instruction decoder is turned off. When the Power-up command is sent to the device, a system initialization is performed (see 5.8 System Initialization on page 20).

## 5.10 Oscillator Characteristics

XIN and XOUT are the input and output of an inverting amplifier to provide oscillation and can be configured as an on-chip oscillator, as shown in Figure 7. The oscillator circuit is designed to work with a quartz crystal. To reduce circuit cost, two load capacitors C1 and C2 are integrated in the device, one between XIN and DGND, one between XOUT and DGND. Lead lengths should be minimized to reduce stray capacitance. To drive the device from an external clock source, XOUT should be left unconnected while XIN is driven by the external circuitry. There is an amplifier between XIN and the digital section which provides CMOS-level signals. This amplifier works with sinusoidal inputs so there are no problems with slow edge times.

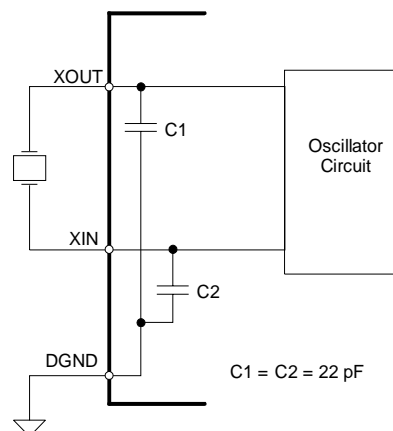

**Figure 7. Oscillator Connection**

The CS5461A can be driven by an external oscillator ranging from 2.5 to 20 MHz, but the K divider value must be set such that the internal DCLK will run somewhere between 2.5 MHz and 5 MHz. The K divider value is set with the K[3:0] bits in the *Configuration Register*. As an example, if XIN = MCLK = 15 MHz, and K is set to 5, then DCLK is 3 MHz, which is a valid value for DCLK.

## 5.11 Event Handler

The  $\overline{\text{INT}}$  pin is used to indicate that an internal error or operation event has taken place in the CS5461A. Writing a logic 1 in the *Mask Register* allows the corresponding bit in the *Status Register* to activate the  $\overline{\text{INT}}$  pin. The interrupt condition is cleared by writing a logic 1 to the status bit that is asserted in the *Status Register*.

The behavior of the  $\overline{\text{INT}}$  pin is controlled by the IMODE and IINV bits of the *Configuration Register*.

IMODE	IINV	$\overline{\text{INT}}$ Pin
0	0	Active Low Level
0	1	Active High Level
1	0	Falling Edge
1	1	Rising Edge

**Table 3. Interrupt Configuration**

If the interrupt output signal format is set for either falling or rising edge, the duration of the  $\overline{\text{INT}}$  pulse will be at least one DCLK cycle (DCLK = MCLK/K).

### 5.11.1 Typical Interrupt Handler

The steps below show how interrupts can be handled.

#### INITIALIZATION:

- 1) All Status bits are cleared by writing 0xFFFFF into the Status Register.
- 2) The conditional bits which will be used to generate

interrupts are then set to logic 1 in the Mask Register.

3) Enable interrupts.

INTERRUPT HANDLER ROUTINE:

4) Read the Status Register.

5) Disable all interrupts.

6) Branch to the proper interrupt service routine.

7) Clear the Status Register by writing back the read value in step 4.

8) Re-enable interrupts.

9) Return from interrupt service routine.

This handshaking procedure insures that any new interrupts activated between steps 4 and 7 are not lost (cleared) by step 7.

## 5.12 Serial Port Overview

The CS5461A incorporates a serial port data transmit and receive buffer with a command decoder that interprets one-byte (8-bit) command words as they are received. There are four types of command words; instructions, synchronizing, register writes, and register reads (See 5.13 Command Words).

Instruction commands are one byte in length and will interrupt any instruction currently executing. Instructions do not affect register reads currently being transmitted. Synchronizing commands are one byte in length and only affect the serial interface. Register write commands must be followed by three bytes of data. Register read commands can return up to four bytes of data.

Command words and data are transferred most-significant bit (MSB) first. Figure 1 on page 11, defines the serial port timing and required sequence necessary to

write to and read from the serial port receive and transmit buffer, respectively. While reading data from the serial port, command words and data can simultaneously be written. Starting a new register read command while data is being read will terminate the current read in progress. This is acceptable if the remainder of the current read data is not needed. During data reads, the serial port requires input data. If a new command word and data is not sent, Sync0 or Sync1 must be sent. Synchronizing command words do not affect operations currently in progress.

### 5.12.1 Serial Port Interface

The serial port interface is a “4-wire” synchronous serial communications interface. The interface is enabled to start excepting SCLKs when  $\overline{CS}$  (Chip Select) is asserted. SCLK (serial bit-clock) is a Schmitt-trigger input that is used to strobe the data on SDI (Serial Data In) into the receive buffer and out of the transmit buffer onto SDO (Serial Data Out).

If the serial port interface becomes unsynchronized, with respect to the SCLK input, any attempt to clock valid command words into the serial interface may result in unexpected operation. The serial port interface must then be re-initialized by one of the following actions:

- Drive the  $\overline{CS}$  pin low [or if  $\overline{CS}$  pin is already low, drive the pin high, then back to low].
- Hardware Reset (drive  $\overline{RESET}$  pin low, for at least 10  $\mu$ s).
- Issue the *Serial Port Initialization Sequence*, which is performed by clocking 3 (or more) SYNC1 command bytes (0xFF) followed by one SYNC0 command byte (0xFE).



## 5.13 Command Words

All command words are 1 byte in length. Any 8-bit word that is not listed in this section is considered an invalid command word. Commands that write to a register must be followed by 3 bytes of register data. Commands that read data can be chained with other commands (e.g., while reading data, a new command can be sent to SDI which can execute before the original read is completed).

### 5.13.1 Start Conversions

B7	B6	B5	B4	B3	B2	B1	B0
1	1	1	0	C3	0	0	0

Initiates acquiring measurements and calculating results. The device has four modes of acquisition.

C3	Modes of acquisition/measurement
	0 = Perform a single computation cycle
	1 = Perform continuous computation cycles

### 5.13.2 SYNC0 and SYNC1 Command

B7	B6	B5	B4	B3	B2	B1	B0
1	1	1	1	1	1	1	SYNC

The serial port is resynchronized to byte boundaries by sending three or more consecutive SYNC1 commands followed by a SYNC0 command. The SYNC0 or SYNC1 commands can also be used as a NOP command.

SYNC	Designates calibration
	0 = This command is the end of the serial port re-initialization sequence.
	1 = This command is part of the serial port re-initialization sequence.

### 5.13.3 Power-Up/Halt

B7	B6	B5	B4	B3	B2	B1	B0
1	0	1	0	0	0	0	0

If the device is powered-down, Power-Up/Halt will initiate a power on reset. If the part is already powered-on, all computations will be halted.

### 5.13.4 Power-down and Software Reset

B7	B6	B5	B4	B3	B2	B1	B0
1	0	0	S1	S0	0	0	0

To conserve power the CS5461A has two power-down states. In stand-by state all circuitry, except the analog/digital clock generators, is turned off. In the sleep state all circuitry, except the digital clock generator and the command decoder, is turned off. Bringing the CS5461A out of sleep state requires more time than out of stand-by state, because of the extra time needed to re-start and re-stabilize the analog clock signal.

S[1:0]	Power-down state
	00 = Software Reset
	01 = Halt and enter stand-by power saving state. This state allows quick power-on time
	10 = Halt and enter sleep power saving state. This state requires a slow power-on time
	11 = Reserved

### 5.13.5 Register Read/Write

B7	B6	B5	B4	B3	B2	B1	B0
0	W/R	RA4	RA3	RA2	RA1	RA0	0

The Read/Write informs the command decoder that a register access is required. During a *read* operation, the addressed register is loaded into the device's output buffer and clocked out by SCLK. During a *write* operation, the data is clocked into the input buffer and transferred to the addressed register upon completion of the 24<sup>th</sup> SCLK.

$\overline{W/R}$  Write/Read control  
 0 = Read register  
 1 = Write register

RA[4:0] Register address bits (bits 5 through 1) of the read/write command.

Address	RA[4:0]	Name	Description
0	00000	Config	Configuration
1	00001	IdCoff	Current DC Offset
2	00010	I <sub>gn</sub>	Current Gain
3	00011	V <sub>DCoff</sub>	Voltage DC Offset
4	00100	V <sub>gn</sub>	Voltage Gain
5	00101	Cycle Count	Number of A/D conversions used in one computation cycle (N).
6	00110	PulseRateE <sub>1,2</sub>	Sets the $\overline{E1}$ and $\overline{E2}$ energy-to-frequency output pulse rate.
7	00111	I	Instantaneous Current
8	01000	V	Instantaneous Voltage
9	01001	P	Instantaneous Power
10	01010	P <sub>Active</sub>	Active (Real) Power
11	01011	I <sub>RMS</sub>	RMS Current
12	01100	V <sub>RMS</sub>	RMS Voltage
14	01110	P <sub>off</sub>	Power Offset Calibration
15	01111	Status	Status (Write of '1' to status bit will clear the bit.)
16	10000	I <sub>ACoff</sub>	Current AC (RMS) Offset
17	10001	V <sub>ACoff</sub>	Voltage AC (RMS) Offset
18	10010	PulseRateE <sub>3</sub>	Sets the $\overline{E3}$ energy-to-frequency output pulse rate.
19	10011	T	Temperature
20	10100	SYS <sub>Gain</sub>	System Gain
21	10101	PW	Pulse width register for mechanical counter output mode
23	10111	VSAG <sub>Duration</sub>	Voltage Sag Duration
24	11000	VSAG <sub>Level</sub>	Voltage Sag Level Threshold
26	11010	Mask	Mask
28	11100	Ctrl	Control
29	11101	T <sub>Gain</sub>	Temperature Sensor Gain
30	11110	T <sub>off</sub>	Temperature Sensor Offset
31	11111	S	Apparent Power Register (From last computation cycle)

Note: For proper operation, *do not* attempt to write to unspecified registers.

### 5.13.6 Calibration

B7	B6	B5	B4	B3	B2	B1	B0
1	1	0	CAL4	CAL3	CAL2	CAL1	CAL0

The CS5461A can perform system calibrations. Proper input signals must be applied to the current and voltage channel before performing a designated calibration.

CAL[4:0]*	Designates calibration to be performed
	01001 = Current channel DC offset
	01010 = Current channel DC gain
	01101 = Current channel AC offset
	01110 = Current channel AC gain
	10001 = Voltage channel DC offset
	10010 = Voltage channel DC gain
	10101 = Voltage channel AC offset
	10110 = Voltage channel AC gain
	11001 = Current and Voltage channel DC offset
	11010 = Current and Voltage channel DC gain
	11101 = Current and Voltage channel AC offset
	11110 = Current and Voltage channel AC gain

\*Values for CAL[4:0] not specified should not be used.



## 6. REGISTER DESCRIPTION

1. "Default\*\*" => bit status after power-on or reset
2. Any bit not labeled is Reserved. A zero should always be used when writing to one of these bits.

### 6.1 Configuration Register

Address: 0

<b>23</b>	<b>22</b>	<b>21</b>	<b>20</b>	<b>19</b>	<b>18</b>	<b>17</b>	<b>16</b>
PC6	PC5	PC4	PC3	PC2	PC1	PC0	lgain
<b>15</b>	<b>14</b>	<b>13</b>	<b>12</b>	<b>11</b>	<b>10</b>	<b>9</b>	<b>8</b>
EWA			IMODE	IINV	EPP	EOP	EDP
<b>7</b>	<b>6</b>	<b>5</b>	<b>4</b>	<b>3</b>	<b>2</b>	<b>1</b>	<b>0</b>
ALT	VHPF	IHPF	iCPU	K3	K2	K1	K0

Default\*\* = 0x000001

PC[6:0]	Phase compensation. A 2's complement number which sets the delay in the voltage channel. When MCLK = 4.096 MHz and K = 1, the phase adjustment range is approximately $\pm 2.8$ degrees with each step approximately 0.04 degrees (assuming a power line frequency of 60 Hz). If (MCLK/K) is not 4.096 MHz, the values for the range and step size should be scaled by the factor 4.096 MHz / (MCLK/K).  Default setting is 0000000 = 0.0215 degrees phase delay at 60 Hz (when MCLK = 4.096 MHz).
lgain	Sets the gain of the current PGA 0 = Gain is 10x (default) 1 = Gain is 50x
EWA	Allows the $\overline{E1}$ and $\overline{E2}$ pins to be configured as open-collector output pins. 0 = Normal outputs (default) 1 = Only the pull-down device of the $\overline{E1}$ and $\overline{E2}$ pins are active
IMODE, IINV	Soft interrupt configuration bits. Select the desired pin behavior for indication of an interrupt. 00 = Active low level (default) 01 = Active high level 10 = Falling edge (INT is normally high) 11 = Rising edge (INT is normally low)
EPP	Allows the $\overline{E1}$ and $\overline{E2}$ pins to be controlled by the EOP and EDP bits. 0 = Normal operation of the $\overline{E1}$ and $\overline{E2}$ pins. (default) 1 = EOP and EDP bits defines the $\overline{E1}$ and $\overline{E2}$ pins.
EOP	EOP defines the value of the $\overline{E1}$ pin when EPP = 1. 0 = Logic level low (default)
EDP	EDP defines the value of the $\overline{E2}$ pin when EPP = 1. 0 = Logic level low (default)
ALT	Alternate pulse format, $\overline{E1}$ and $\overline{E2}$ becomes active low alternating pulses with an output frequency proportional to the active power. 0 = Normal (default), Mechanical Counter or Stepper Motor Format 1 = Alternate Pulse Format, also MECH = 1
VHPF	Enables the high-pass filter on the voltage channel. 0 = High-pass filter disabled (default) 1 = High-pass filter enabled

- IHPF** Enables the high-pass filter on the current channel.  
 0 = High-pass filter disabled (default)  
 1 = High-pass filter enabled
- iCPU** Inverts the CPUCLK clock. In order to reduce the level of noise present when analog signals are sampled, the logic driven by CPUCLK should not be active during the sample edge.  
 0 = Normal operation (default)  
 1 = Minimize noise when CPUCLK is driving rising-edge logic
- K[3:0]** Clock divider. A 4-bit binary number used to divide the value of MCLK to generate the internal clock DCLK. The internal clock frequency is  $DCLK = MCLK/K$ . The value of K can range between 1 and 16. Note that a value of "0000" will set K to 16 (not zero).

### 6.2 Current DC Offset Register and Voltage DC Offset Register

Address: 1 (Current DC Offset Register); 3 (Voltage DC Offset Register)

MSB													LSB		
$-(2^0)$	$2^{-1}$	$2^{-2}$	$2^{-3}$	$2^{-4}$	$2^{-5}$	$2^{-6}$	$2^{-7}$	.....	$2^{-17}$	$2^{-18}$	$2^{-19}$	$2^{-20}$	$2^{-21}$	$2^{-22}$	$2^{-23}$

Default\*\* = 0x000000

The DC Offset registers ( $I_{DCoff}, V_{DCoff}$ ) are initialized to 0.0 on reset. When DC Offset calibration is performed, the register is updated with the DC offset calculation derived over a computation cycle. DRDY will be asserted at the end of the calibration. The register may be read and stored for future system offset compensation. The value is in the range of  $-1.0 \leq I_{DCoff}, V_{DCoff} < 1.0$ . The value is represented in two's complement notation, with the binary point to the right of the MSB (MSB has a negative weighting).

### 6.3 Current Gain Register and Voltage Gain Register

Address: 2 (Current Gain Register); 4 (Voltage Gain Register)

MSB													LSB		
$2^1$	$2^0$	$2^{-1}$	$2^{-2}$	$2^{-3}$	$2^{-4}$	$2^{-5}$	$2^{-6}$	.....	$2^{-16}$	$2^{-17}$	$2^{-18}$	$2^{-19}$	$2^{-20}$	$2^{-21}$	$2^{-22}$

Default\*\* = 0x800000 = 1.000

The gain registers ( $I_{gn}, V_{gn}$ ) are initialized to 1.0 on reset. When either a AC or DC Gain calibration is performed, the register is updated with the gain calculation derived over a computation cycle. DRDY will be asserted at the end of the calibration. The register may be read and stored for future system gain compensation. The value is in the range  $0.0 \leq I_{gn}, V_{gn} < 3.9999$ , with the binary point to the right of the second MSB.

### 6.4 Cycle Count Register

Address: 5

MSB													LSB		
$2^{23}$	$2^{22}$	$2^{21}$	$2^{20}$	$2^{19}$	$2^{18}$	$2^{17}$	$2^{16}$	.....	$2^6$	$2^5$	$2^4$	$2^3$	$2^2$	$2^1$	$2^0$

Default\*\* = 0x000FA0 = 4000

The Cycle Count, denoted as N, determines the length of one *computation cycle*. During continuous conversions, the computation cycle frequency is  $(MCLK/K)/(1024*N)$ . A one second computational cycle period occurs when  $MCLK = 4.096$  MHz,  $K = 1$ , and  $N = 4000$ .

### 6.5 *PulseRateE<sub>1,2</sub> Register*

Address: 6

MSB										LSB					
2 <sup>18</sup>	2 <sup>17</sup>	2 <sup>16</sup>	2 <sup>15</sup>	2 <sup>14</sup>	2 <sup>13</sup>	2 <sup>12</sup>	2 <sup>11</sup>	.....	2 <sup>1</sup>	2 <sup>0</sup>	2 <sup>-1</sup>	2 <sup>-2</sup>	2 <sup>-3</sup>	2 <sup>-4</sup>	2 <sup>-5</sup>

Default\*\* = 0xFA0000 = 32000.00 Hz

*PulseRateE<sub>1,2</sub>* determines the pulse output frequency of the  $\overline{E1}$  and/or  $\overline{E2}$  pins. The smallest valid frequency is 2<sup>-4</sup> with 2<sup>-5</sup> incremental steps. A pulse rate higher than (MCLK/K)/8 will result in a pulse rate setting of (MCLK/K)/8. The value is represented in unsigned notation, with the binary point to the right of bit 5.

### 6.6 *Instantaneous Current, Voltage and Power Registers*

Address: 7 (Instantaneous Current Register); 8 (Instantaneous Voltage Register); 9 (Instantaneous Power Register)

MSB										LSB					
-(2 <sup>0</sup> )	2 <sup>-1</sup>	2 <sup>-2</sup>	2 <sup>-3</sup>	2 <sup>-4</sup>	2 <sup>-5</sup>	2 <sup>-6</sup>	2 <sup>-7</sup>	.....	2 <sup>-17</sup>	2 <sup>-18</sup>	2 <sup>-19</sup>	2 <sup>-20</sup>	2 <sup>-21</sup>	2 <sup>-22</sup>	2 <sup>-23</sup>

I and V contain the instantaneous measured values for current and voltage, respectively. The instantaneous voltage and current data samples are multiplied together to obtain Instantaneous Power (P). The value will be within in the range of -1.0 ≤ I,V,P < 1.0. The value is represented in two's complement notation, with the binary point to the right of the MSB (MSB has a negative weighting).

### 6.7 *Active (Real) Power Registers*

Address: 10 (Active Power Register)

MSB										LSB					
-(2 <sup>0</sup> )	2 <sup>-1</sup>	2 <sup>-2</sup>	2 <sup>-3</sup>	2 <sup>-4</sup>	2 <sup>-5</sup>	2 <sup>-6</sup>	2 <sup>-7</sup>	.....	2 <sup>-17</sup>	2 <sup>-18</sup>	2 <sup>-19</sup>	2 <sup>-20</sup>	2 <sup>-21</sup>	2 <sup>-22</sup>	2 <sup>-23</sup>

The instantaneous power is averaged over each computation cycle (N conversions) to compute Active Power (P<sub>Active</sub>). The value will be within in the range of -1.0 ≤ P<sub>Active</sub> < 1.0. The value is represented in two's complement notation, with the binary point place to the right of the MSB (MSB has a negative weighting).

### 6.8 *I<sub>RMS</sub>, V<sub>RMS</sub> Registers*

Address: 11 (I<sub>RMS</sub> Register); 12 (V<sub>RMS</sub> Register)

MSB										LSB					
2 <sup>-1</sup>	2 <sup>-2</sup>	2 <sup>-3</sup>	2 <sup>-4</sup>	2 <sup>-5</sup>	2 <sup>-6</sup>	2 <sup>-7</sup>	2 <sup>-8</sup>	.....	2 <sup>-18</sup>	2 <sup>-19</sup>	2 <sup>-20</sup>	2 <sup>-21</sup>	2 <sup>-22</sup>	2 <sup>-23</sup>	2 <sup>-24</sup>

I<sub>RMS</sub> and V<sub>RMS</sub> contain the Root Mean Square (RMS) results, calculated each computation cycle. The value will be in the range of 0.0 ≤ I<sub>RMS</sub>,V<sub>RMS</sub> < 1.0. The value is represented in unsigned binary notation, with the binary point to the left of the MSB.

### 6.9 Power Offset Register

Address: 14

MSB														LSB	
$-(2^0)$	$2^{-1}$	$2^{-2}$	$2^{-3}$	$2^{-4}$	$2^{-5}$	$2^{-6}$	$2^{-7}$	.....	$2^{-17}$	$2^{-18}$	$2^{-19}$	$2^{-20}$	$2^{-21}$	$2^{-22}$	$2^{-23}$

Default\*\* = 0x000000

This Power Offset ( $P_{off}$ ) value is added to each instantaneous power value being accumulated in the energy register. This register can be used to offset contributions to the energy result that are caused by undesirable sources of energy that are inherent in the system. Values will be within in the range of  $-1.0 \leq P_{off} < 1.0$ . The value is represented in two's complement notation, with the binary point to the right of the MSB (MSB has a negative weighting).

### 6.10 Status Register and Mask Register

Address: 15 (Status Register); 26 (Mask Register)

<b>23</b>	<b>22</b>	<b>21</b>	<b>20</b>	<b>19</b>	<b>18</b>	<b>17</b>	<b>16</b>
DRDY	E1	E2	CRDY			IOR	VOR
<b>15</b>	<b>14</b>	<b>13</b>	<b>12</b>	<b>11</b>	<b>10</b>	<b>9</b>	<b>8</b>
	IROR	VROR		EOOR			
<b>7</b>	<b>6</b>	<b>5</b>	<b>4</b>	<b>3</b>	<b>2</b>	<b>1</b>	<b>0</b>
TUP	TOD		VOD	IOD	LSD	VSAG	IC

Default\*\* = 0x000000 (Status and Mask Register)

The Status Register indicates the condition of the chip. In normal operation, writing a '1' to a bit will cause the bit to go to the '0' state. Writing a '0' to a bit will maintain the status bit in its current state. With this feature the user can simply write to the Status Register to clear the bits that have been seen, without concern of clearing any newly set bits. Even if a status bit is masked to prevent an interrupt, the status bit will still be set in the Status Register.

The Mask Register is used to control the activation of the  $\overline{INT}$  pin. Placing a logic '1' in the Mask Register will allow the corresponding bit in the Status Register to activate the  $\overline{INT}$  pin when the status bit is asserted.

**DRDY** Data Ready. When running in single or continuous conversion acquisition mode, this bit will indicate the end of computation cycles. When running calibrations, this bit indicates the end of a calibration sequence.

**E1** Indicates that the energy limit has been reached for the  $\overline{E1}$  energy accumulation register. The register will be cleared, and one pulse will be generated on the  $\overline{E1}$  pin (if enabled). If  $\overline{E1}$  is asserted, this bit will be cleared automatically just after the beginning of any subsequent A/D conversion cycle in which no  $\overline{E1}$  pulses need to be issued. The bit can be cleared by writing to the Status Register. The E1 bit is set with a maximum frequency of 4 kHz ( $MCLK/K = 4.096$  MHz). When  $MCLK/K$  is not equal to 4.096 MHz, the pulse-rate must be scaled by a correction factor of  $4.096 \text{ MHz}/(MCLK/K)$ , to achieve the actual pulse rate.

**E2** Set whenever the  $\overline{E1}$  bit is asserted as long as the energy result is negative. Reset/Clear behavior of the  $\overline{E2}$  status bit is similar to the  $\overline{E1}$  status bit.

**CRDY** Conversion Ready. Indicates a new conversion is ready. This will occur at the output word rate.

**IOR** Current Out of Range. Set when the magnitude of the measured current value causes the *Instantaneous Current Register* to overflow.

VOR	Voltage Out of Range. Set when the magnitude of the measured voltage value causes the <i>Instantaneous Voltage Register</i> to overflow.
IROR	$I_{RMS}$ Out of Range. Set when the calculated rms current value causes the <i><math>I_{RMS}</math> Register</i> to overflow.
VROR	$V_{RMS}$ Out of Range. Set when the calculated rms voltage value causes the <i><math>V_{RMS}</math> Register</i> to overflow.
EOOR	Energy Summation Register Out of Range. Assertion of this bit can be caused by having a pulse output frequency that is too small for the power being measured. This problem can be corrected by specifying a higher frequency in the <i>PulseRateE<sub>1,2</sub></i> register. The EOOR bit can also be asserted by applying large $\pm P_{off}$ (Power Offset) adjustments to the accumulated Instantaneous Power (P).
TUP	Temperature Updated. Indicates a temperature conversion is ready.
TOD	Modulator oscillation detected on the temperature channel. Set when the modulator oscillates due to an input above full scale. The level at which the modulator oscillates is significantly higher than the temperature channel's input voltage range.
VOD	Modulator oscillation detected on the voltage channel. Set when the modulator oscillates due to an input above full scale. The level at which the modulator oscillates is significantly higher than the voltage channel's differential input voltage range.
IOD	Modulator oscillation detected on the current channel. Set when the modulator oscillates due to an input above full scale. The level at which the modulator oscillates is significantly higher than the current channel's differential input voltage range.
	Note: The IOD and VOD bits may be 'falsely' triggered by very brief voltage spikes from the power line. This event should not be confused with a DC overload situation at the inputs, when the IOD and VOD bits will re-assert themselves even after being cleared, multiple times.
LSD	Low Supply Detect. Set when the voltage at the PFMON pin falls below the low-voltage threshold (PMLO), with respect to AGND pin. For a given part, PMLO can be as low as 2.3 V. LSD bit cannot be permanently reset until the voltage at PFMON pin rises back above the high-voltage threshold (PMHI), which is typically 100 mV above the device's low-voltage threshold. PMHI will never be greater than 2.7 V.
VSAG	Indicates a voltage sag occurred in the power line voltage. If the absolute value of the instantaneous voltage is less than $VSAG_{level}$ for more than half of the $VSAG_{duration}$ , the VSAG bit will be set.
$\overline{IC}$	Invalid Command. Normally logic 1. Set to logic 0 if the host interface is strobed with an 8-bit word that is not recognized as one of the valid commands (see Section 5.13 Command Words).

### 6.11 Current AC Offset Register and Voltage AC Offset Register

Address: 16 (Current AC Offset Register); 17 (Voltage AC Offset Register)

MSB													LSB		
$-(2^0)$	$2^{-1}$	$2^{-2}$	$2^{-3}$	$2^{-4}$	$2^{-5}$	$2^{-6}$	$2^{-7}$	.....	$2^{-17}$	$2^{-18}$	$2^{-19}$	$2^{-20}$	$2^{-21}$	$2^{-22}$	$2^{-23}$

Default\*\* = 0x000000

The AC Offset Registers ( $V_{ACoff}$ ,  $I_{ACoff}$ ) are initialized to zero on reset, allowing for uncalibrated normal operation. When AC Offset Calibration is performed, the offset register(s) is updated with the system AC offset value. This

sequence lasts approximately  $(6N + 30)$  ADC cycles (where N is the value of the Cycle-Count Register). DRDY will be asserted at the end of the calibration. The register value may be read and stored for future system AC offset compensation. Values will be within in the range of  $-1.0 \leq V_{ACoff}, I_{ACoff} < 1.0$ . The value is represented in two's complement notation, with the binary point to the right of the third MSB (MSB has a negative weighting).

### 6.12 PulseRateE<sub>3</sub> Register

Address: 18

MSB								LSB							
$2^{18}$	$2^{17}$	$2^{16}$	$2^{15}$	$2^{14}$	$2^{13}$	$2^{12}$	$2^{11}$	.....	$2^1$	$2^0$	$2^{-1}$	$2^{-2}$	$2^{-3}$	$2^{-4}$	$2^{-5}$

Default\*\* = 0xFA0000 = 32000.00 Hz

The PulseRateE<sub>3</sub> Register sets the pulse output frequency of the  $\overline{E3}$  pin. The register's smallest valid frequency is  $2^{-4}$  with  $2^{-5}$  incremental steps. A pulse rate higher than  $(MCLK/K)/8$  will result in a pulse rate setting of  $(MCLK/K)/8$ . The value is represented in unsigned notation, with the binary point to the right of bit 5.

### 6.13 Temperature Register

Address: 19

MSB								LSB							
$-(2^7)$	$2^6$	$2^5$	$2^4$	$2^3$	$2^2$	$2^1$	$2^0$	.....	$2^{-10}$	$2^{-11}$	$2^{-12}$	$2^{-13}$	$2^{-14}$	$2^{-15}$	$2^{-16}$

T contains the temperature measurements from the on-chip temperature sensor. Measurements are performed during continuous conversions, with the default the Celsius scale (°C). The value is in the range of  $-128.0 \leq T < 128.0$ . The value is represented in signed binary notation, with the binary point place to the left of the eighth MSB.

### 6.14 System Gain Register

Address: 20

MSB								LSB							
$-(2^1)$	$2^0$	$2^{-1}$	$2^{-2}$	$2^{-3}$	$2^{-4}$	$2^{-5}$	$2^{-6}$	.....	$2^{-16}$	$2^{-17}$	$2^{-18}$	$2^{-19}$	$2^{-20}$	$2^{-21}$	$2^{-22}$

Default\*\* = 0x500000 = 1.25

System Gain (SYS<sub>Gain</sub>) determines the one's density of the channel measurements. Small changes in the modulator due to temperature can be fine adjusted by changing the system gain. The value is in the range of  $-2.0 < SYS_{Gain} < 2.0$ . The value is represented in two's complement notation, with the binary point place to the right of the third MSB (MSB has a negative weighting).

### 6.15 Pulsewidth Register

Address: 21

MSB								LSB							
$2^{23}$	$2^{22}$	$2^{21}$	$2^{20}$	$2^{19}$	$2^{18}$	$2^{17}$	$2^{16}$	.....	$2^6$	$2^5$	$2^4$	$2^3$	$2^2$	$2^1$	$2^0$

Default\*\* = 0x000200 = 512 sample periods

PW determines the pulsewidth of  $\overline{E1}$  and  $\overline{E2}$  pulses in Alternate Pulse Format and Mechanical Counter Format. The width is a function of number of sample periods. The default corresponds to a pulsewidth of  $512 \text{ samples} / [(MCLK/K)/1024] = 128 \text{ msec}$  with  $MCLK = 4.096 \text{ MHz}$  and  $K = 1$ . The value is represented in unsigned notation.

### 6.16 Voltage Sag Duration Register

Address: 23

MSB									LSB						
2 <sup>23</sup>	2 <sup>22</sup>	2 <sup>21</sup>	2 <sup>20</sup>	2 <sup>19</sup>	2 <sup>18</sup>	2 <sup>17</sup>	2 <sup>16</sup>	.....	2 <sup>6</sup>	2 <sup>5</sup>	2 <sup>4</sup>	2 <sup>3</sup>	2 <sup>2</sup>	2 <sup>1</sup>	2 <sup>0</sup>

Default\*\* = 0x000000

Voltage Sag Duration (VSAG<sub>Duration</sub>) defines the number of instantaneous voltage measurements utilized to determine a voltage level sag event (VSAG<sub>LEVEL</sub>). Setting this register to zero will disable the Voltage Sag-Detect Feature. The value is represented in unsigned notation.

### 6.17 Voltage Sag Level Register

Address: 24

MSB									LSB						
2 <sup>23</sup>	2 <sup>22</sup>	2 <sup>21</sup>	2 <sup>20</sup>	2 <sup>19</sup>	2 <sup>18</sup>	2 <sup>17</sup>	2 <sup>16</sup>	.....	2 <sup>6</sup>	2 <sup>5</sup>	2 <sup>4</sup>	2 <sup>3</sup>	2 <sup>2</sup>	2 <sup>1</sup>	2 <sup>0</sup>

Default\*\* = 0x000000

Voltage Sag Level (VSAG<sub>Level</sub>) defines the voltage level that the absolute value of the instantaneous voltage (V) is compared against. If the absolute value of V is greater than or equal to the voltage sag level for at least half of the voltage sag duration, the status bit VSAG in the *Status Register* will remain zero. The value is represented in unsigned notation.

### 6.18 Control Register

Register Address: 28

23	22	21	20	19	18	17	16
15	14	13	12	11	10	9	8
					FAC	EAC	STOP
7	6	5	4	3	2	1	0
	MECH		INTOD		NOCPU	NOOSC	STEP

Default\*\* = 0x000000

**FAC** Determines if anti-creep is enabled for pulse output  $\overline{E3}$ .  
 0 = Disable anti-creep (default)  
 1 = Enabled anti-creep

**EAC** Determines if anti-creep is enabled for pulse output  $\overline{E1}$  and/or  $\overline{E2}$ .  
 0 = Disable anti-creep (default)  
 1 = Enabled anti-creep

**STOP** Terminates the auto-boot initialization sequence.  
 0 = Normal (default)  
 1 = Stop sequence

**MECH** Mechanical Counter Format,  $\overline{E1}$  or  $\overline{E2}$  becomes active low pulses with an output frequency proportional to the active power  
 0 = Normal (default) or Stepper Motor Format  
 1 = Mechanical Counter Format, also ALT = 0

INTOD	Converts $\overline{\text{INT}}$ output pin to an open drain configuration. 0 = Normal (default) 1 = Open drain
NOCPU	Saves power by disabling the CPUCLK external drive pin. 0 = Normal (default) 1 = Disables CPUCLK
NOOSC	Saves power by disabling the crystal oscillator circuit. 0 = Normal (default) 1 = Disabling oscillator circuit
STEP	Stepper Motor Format, $\overline{\text{E1}}$ and $\overline{\text{E2}}$ becomes active low pulses with an output frequency proportional to the active power 0 = Normal Format (default) 1 = Stepper Motor Format, also MECH = 0 and ALT = 0

### 6.19 Temperature Gain Register

Address: 29

MSB														LSB	
$2^6$	$2^5$	$2^4$	$2^3$	$2^2$	$2^1$	$2^0$	$2^{-1}$	.....	$2^{-11}$	$2^{-12}$	$2^{-13}$	$2^{-14}$	$2^{-15}$	$2^{-16}$	$2^{-17}$

Default\*\* = 0x2F9903 = 23.798851

Temperature gain ( $T_{\text{Gain}}$ ) is utilized to convert from one temperature scale to another. The Celsius scale ( $^{\circ}\text{C}$ ) is the default. Values will be within in the range of  $0 \leq T_{\text{Gain}} < 128$ . The value is represented in unsigned notation, with the binary point place to the right of bit 17.

### 6.20 Temperature Offset Register

Address: 30

MSB														LSB	
$-(2^0)$	$2^{-1}$	$2^{-2}$	$2^{-3}$	$2^{-4}$	$2^{-5}$	$2^{-6}$	$2^{-7}$	.....	$2^{-17}$	$2^{-18}$	$2^{-19}$	$2^{-20}$	$2^{-21}$	$2^{-22}$	$2^{-23}$

Default\*\* = 0xF45887 = -0.09104836

Temperature offset ( $T_{\text{off}}$ ) sets the zero degree measured voltage, based on the gain of the temperature sensor subsystem. Values will be within in the range of  $-1.0 \leq T_{\text{off}} < 1.0$ . The value is represented in two's complement notation, with the binary point place to the right of the MSB (MSB has a negative weighting).

### 6.21 Apparent Power Register

Address: 31

MSB														LSB	
$2^{-1}$	$2^{-2}$	$2^{-3}$	$2^{-4}$	$2^{-5}$	$2^{-6}$	$2^{-7}$	$2^{-8}$	.....	$2^{-18}$	$2^{-19}$	$2^{-20}$	$2^{-21}$	$2^{-22}$	$2^{-23}$	$2^{-24}$

Apparent power (S) is the product of the  $V_{\text{RMS}}$  and  $I_{\text{RMS}}$ , and is in the range of  $0.0 \leq S < 1.0$ . The value is represented in unsigned binary notation, with the binary point place to the left of the MSB. This result is updated after each computation cycle.



## 7. SYSTEM CALIBRATION

### 7.1 Channel Offset and Gain Calibration

The CS5461A provides digital DC-offset and gain compensation that can be applied to the instantaneous voltage and current measurements, and AC-offset compensation to the voltage and current RMS calculations.

Since the voltage and current channels have independent offset and gain registers, system offset and/or gain can be performed on either channel without the calibration results from one channel affecting the other.

The computational flow of the calibration sequences are illustrated in Figure 8. The flow applies to both the voltage channel and current channel.

#### 7.1.1 Calibration Sequence

The CS5461A must be operating in its active state and ready to accept valid commands. Refer to Section 5.13 Command Words on page 22. The calibration algorithms are dependent on the value N in the *Cycle Count Register* (see Figure 8). Upon completion, the results of the calibration are available in their corresponding register. The DRDY bit in the *Status Register* will be set. If the DRDY bit is to be output on the INT pin, then DRDY bit in the *Mask Register* must be set. The initial values stored in the AC gain and offset registers do affect the calibration results.

##### 7.1.1.1 Duration of Calibration Sequence

The value of the *Cycle Count Register* (N) determines the number of conversions performed by the CS5461A during a given calibration sequence. For DC-offset and gain calibrations, the calibration sequence takes at least

$N + 30$  conversion cycles to complete. For AC offset calibrations, the calibration sequence takes at least  $6N + 30$  ADC cycles to complete, (about 6 computation cycles). As N is increased, the accuracy of calibration results will increase.

#### 7.1.2 Offset Calibration Sequence

For DC- and AC-offset calibrations, the  $V_{IN\pm}$  pins of the voltage and  $I_{IN\pm}$  pins of the current channels should be connected to their ground-reference level. (see Figure 9.)

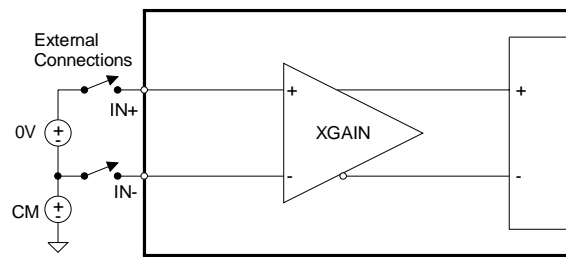
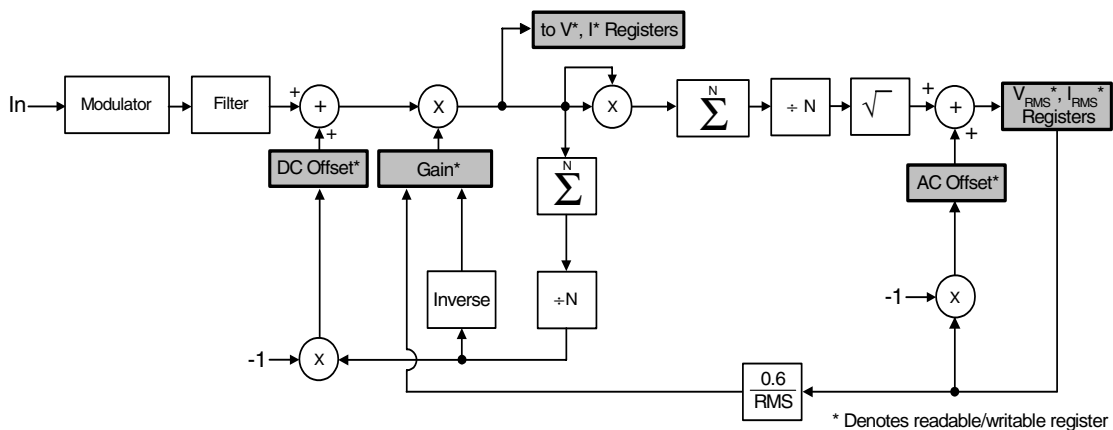

**Figure 9. System Calibration of Offset.**

The DC and AC offset registers must be set to the default (0.0).

##### 7.1.2.1 DC Offset Calibration Sequence

Initiate a DC-offset calibration. The DC offset registers are updated with the negative of the average of the instantaneous samples taken over a computational cycle. Upon completion of the DC-offset calibration the DC offset is stored in the corresponding DC offset register. The DC-offset value is added to each instantaneous



**Figure 8. Calibration Data Flow**

measurement to nullify the DC component present in the system.

### 7.1.2.2 AC Offset Calibration Sequence

Initiate an AC-offset calibration. The AC offset registers are updated with an offset value that reflects the RMS output level. Upon completion of the AC-offset calibration the AC offset is stored in the corresponding AC offset register. The AC offset register value is subtracted from each successive  $V_{RMS}$  and  $I_{RMS}$  calculation.

### 7.1.3 Gain Calibration Sequence

When performing gain calibrations, a reference signal should be applied to the  $VIN_{\pm}$  pins of the voltage and  $IIN_{\pm}$  pins of the current channels that represents the desired maximum signal level. Figure 10 shows the basic setup for gain calibration.

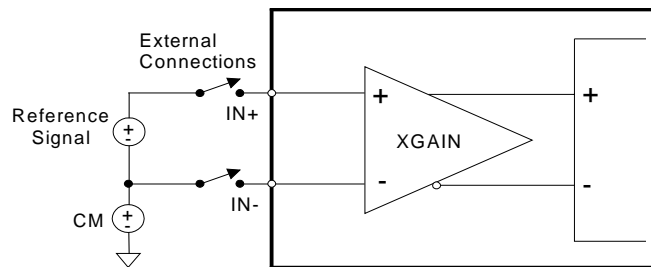

**Figure 10. System Calibration of Gain.**

For gain calibrations, there is an absolute limit on the RMS voltage levels that are selected for the gain-calibration input signals. The maximum value that the gain registers can attain is 4. Therefore, if the signal level of the applied input is low enough that it causes the CS5461A to attempt to set either gain register higher than 4, the gain calibration result will be invalid and all CS5461A results obtained while performing measurements will be invalid.

If the channel gain registers are initially set to a gain other than 1.0, AC gain calibration should be used.

#### 7.1.3.1 AC Gain Calibration Sequence

The channel gain register should be default (1.0), unless a different gain value is desired. Initiate an AC gain calibration. The AC gain calibration algorithm computes the RMS value of the reference signal applied to the channel inputs. The RMS register value is then divided into 0.6 and the quotient is stored in the corresponding gain register. Each instantaneous measurement is multiplied by its corresponding AC gain value.

A typical sinusoidal calibration value which allows for reasonable over-range margin would be 0.6 or 60% of

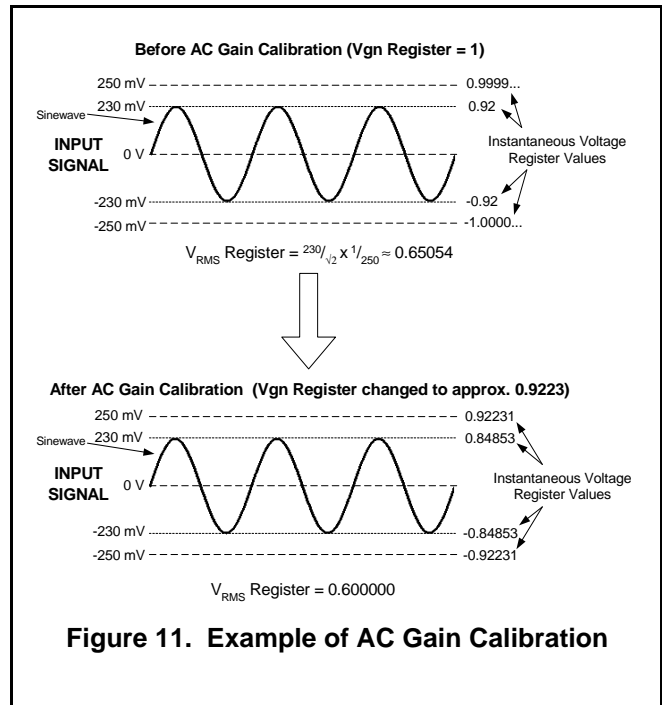

**Figure 11. Example of AC Gain Calibration**

the voltage and current channel's maximum input-voltage level.

Two examples of AC gain calibration and the updated digital output codes of the channel's instantaneous data registers are shown in Figures 11 and 12. Figure 12 shows that a positive (or negative), DC-level signal can be used even though an AC gain calibration is being executed.

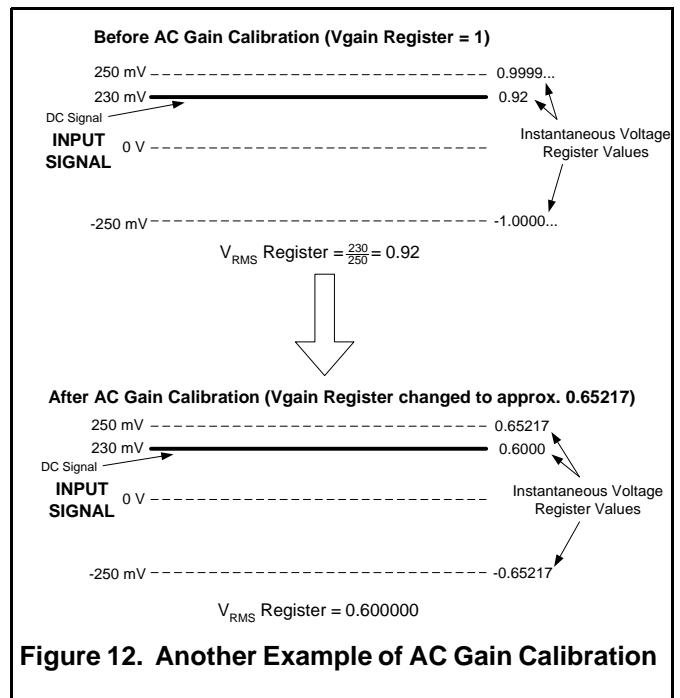

**Figure 12. Another Example of AC Gain Calibration**

However, an AC signal cannot be used for DC gain calibration.

### 7.1.3.2 DC Gain Calibration Sequence

Initiate a DC gain calibration. The channel gain register is restored to default (1.0). The DC gain calibration algorithm averages the channel's instantaneous measurements over one computation cycle (N samples). The average is then divided into 1.0 and the quotient is stored in the corresponding gain register

After the DC gain calibration, the instantaneous register will read at full-scale whenever the DC level of the input signal is equal to the level of the DC calibration signal applied to the inputs during the DC gain calibration. The HPF option should not be enabled if DC gain calibration is utilized.

### 7.1.4 Order of Calibration Sequences

1. If the HPF option is enabled, then any DC component that may be present in the selected signal path will be removed and a DC-offset calibration is not required. However, if the HPF option is disabled the DC-offset calibration sequence should be performed.
2. If there is an AC offset in the  $V_{RMS}$  or  $I_{RMS}$  calculation, then the AC-offset calibration sequence should be performed.
3. Perform the gain calibration sequence.
4. Finally, if an AC-offset calibration was performed (step 2), then the AC-offset value needs to be adjusted to compensate for the change in gain (step 3). This can be accomplished by restoring zero to the AC offset register and then perform an AC-offset calibration se-

quence. The adjustment could also be done by multiplying the AC offset register value that was calculated in step 2 by the gain calculated in step 3 and updating the AC offset register with the product.

## 7.2 Phase Compensation

The CS5461A is equipped with phase compensation to nullify phase shifts introduced by the measurement element. Phase Compensation is determined by bits PC[6:0] in the *Configuration Register*.

The default value of PC[6:0] is zero. With MCLK = 4.096 MHz and K = 1, the phase compensation has a range of  $\pm 2.8$  degrees when the input signals are 60 Hz. Under these conditions, each step of the phase compensation register (value of one LSB) is approximately 0.04 degrees. For values of MCLK other than 4.096 MHz, the range and step size should be scaled by  $4.096 \text{ MHz}/(\text{MCLK}/K)$ . For power-line frequencies other than 60Hz, the values of the range and step size of the PC[6:0] bits can be determined by converting the above values to time-domain (seconds), and then computing the new range and step size (in degrees) with respect to the new line frequency.

## 7.3 Active Power Offset

The *Power Offset Register* can be used to offset system power sources that may be resident in the system, but do not originate from the power-line signal. These sources of extra energy in the system contribute undesirable and false offsets to the power and energy measurement results. After determining the amount of stray power, the Power Offset Register can be set to nullify the effects of this unwanted energy.

## 8. AUTO-BOOT MODE USING E<sup>2</sup>PROM

When the CS5461A MODE pin is set to logic high, the CS5461A *auto-boot mode* is enabled. In auto-boot mode, the CS5461A downloads the required commands and register data from an external serial E<sup>2</sup>PROM, allowing the CS5461A to begin performing energy measurements.

### 8.1 Auto-Boot Configuration

A typical auto-boot serial connection between the CS5461A and a E<sup>2</sup>PROM is illustrated in Figure 13. In auto-boot mode, the CS5461A's CS and SCLK are configured as outputs. The CS5461A asserts CS, provides a clock on SCLK, and writes a download command to the E<sup>2</sup>PROM on SDO. The CS5461A reads the user-specified commands and register data presented on the SDI pin. The E<sup>2</sup>PROM's programmed data is utilized by the CS5461A to change the designated registers' default values and begin registering energy.

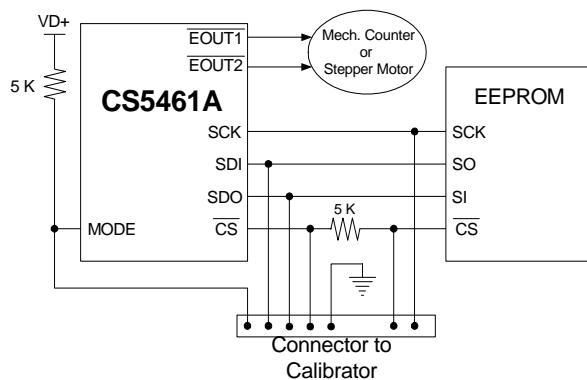

**Figure 13. Typical Interface of E<sup>2</sup>PROM to CS5461A**

Figure 13 also shows the external connections that would be made to a calibrator device, such as a PC or custom calibration board. When the metering system is installed, the calibrator would be used to control calibration and/or to program user-specified commands and calibration values into the E<sup>2</sup>PROM. The user-specified commands/data will determine the CS5461A's exact

operation, when the auto-boot initialization sequence is running. Any of the valid commands can be used.

### 8.2 Auto-Boot Data for E<sup>2</sup>PROM

Below is an example code set for an auto-boot sequence. This code is written into the E<sup>2</sup>PROM by the user. The serial data for such a sequence is shown below in single-byte, hexadecimal notation:

- 40 00 00 61  
Write Configuration Register, turn high-pass filters on, set K=1.
- 44 7F C4 A9  
Write value of 0x7FC4A9 to Current Gain Register.
- 46 FF B2 53  
Write value of 0xFFB253 to DC Voltage Offset Register.
- 4C 00 00 14  
Set PulseRateE<sub>1,2</sub> Register to 0.625 Hz.
- 74 00 00 04  
Unmask bit #2 ("LSD" bit in the Mask Register).
- E8  
Start continuous conversions
- 78 00 01 40  
Write STOP bit to Control Register, to terminate auto-boot initialization sequence, and set the E1 pulse output to Mechanical Counter Format.

### 8.3 Suggested E<sup>2</sup>PROM Devices

Several industry-standard, serial E<sup>2</sup>PROMs that will successfully run auto-boot with the CS5461A are listed below:

- Atmel AT25010, AT25020 or AT25040
- National Semiconductor NM25C040M8 or NM25020M8
- Xicor X25040SI

These types of serial E<sup>2</sup>PROMs expect a specific 8-bit command word (00000011) in order to perform a memory download. The CS5461A has been hardware programmed to transmit this 8-bit command word to the E<sup>2</sup>PROM at the beginning of the auto-boot sequence.

## 9. BASIC APPLICATION CIRCUITS

Figure 14 shows the CS5461A configured to measure power in a single-phase, 2-wire system while operating in a single-supply configuration. In this diagram, a shunt resistor is used to sense the line current and a voltage divider is used to sense the line voltage. In this type of shunt resistor configuration, the common-mode level of the CS5466 must be referenced to the line side of the power line. This means that the common-mode potential of the CS5461A will track the high-voltage levels, as well as low-voltage levels, with respect to earth ground potential. Isolation circuitry is required when an earth-ground-referenced communication interface is connected.

Figure 15 shows the same single-phase, two-wire system with complete isolation from the power lines. This isolation is achieved using three transformers: a general purpose transformer to supply the on-board DC power; a high-precision, low-impedance voltage transformer with very little roll-off/phase-delay, to measure voltage; and a current transformer to sense the line current.

Figure 16 shows a single-phase, 3-wire system. In many 3-wire residential power systems within the United States, only the two line terminals are available (neutral is not available). Figure 17 shows the CS5461A configured to meter a three-wire system with no neutral available.

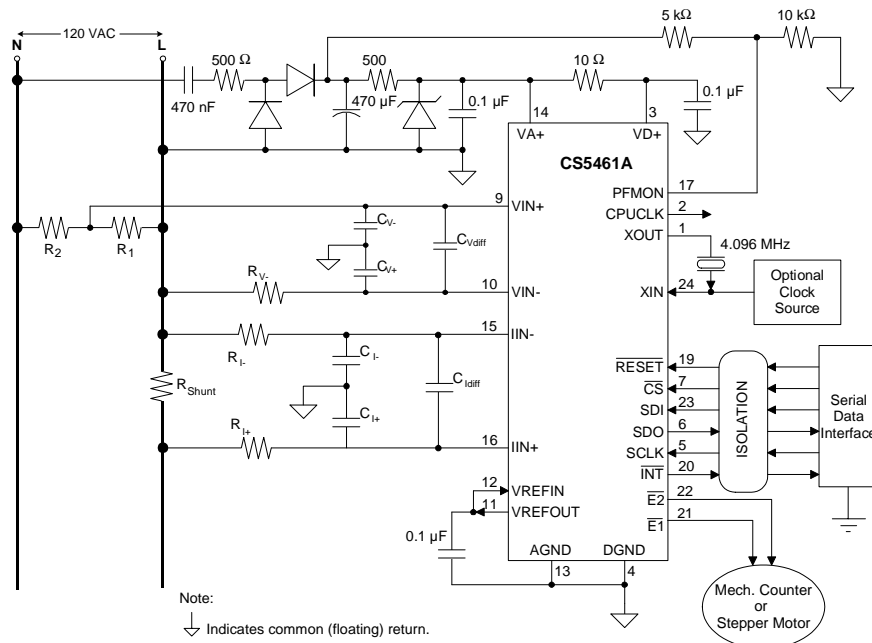

**Figure 14. Typical Connection Diagram (One-Phase 2-Wire, Direct Connect to Power Line)**

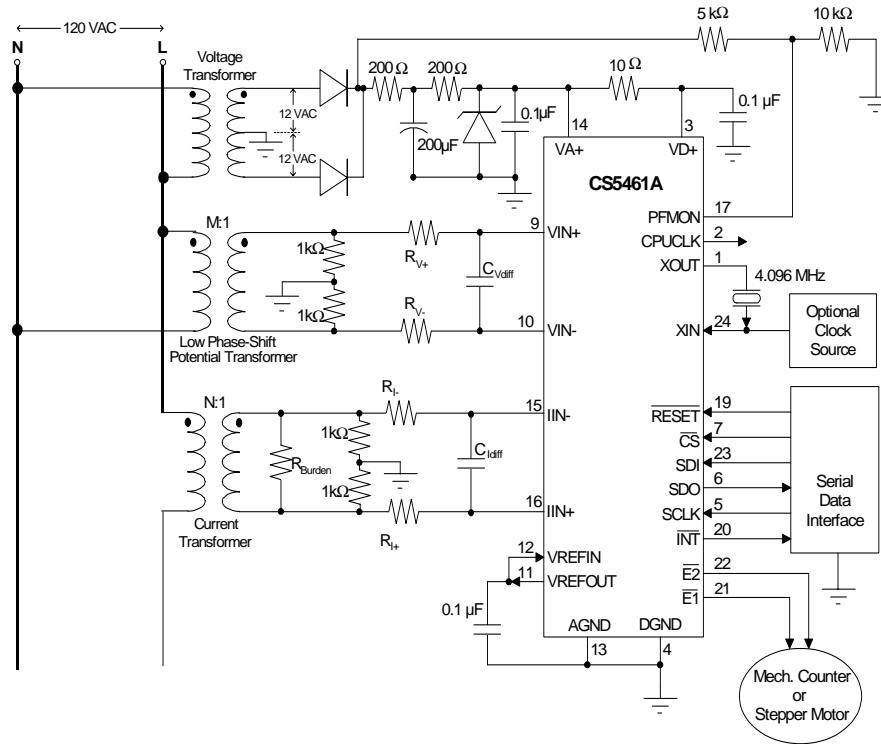

**Figure 15. Typical Connection Diagram (One-Phase 2-Wire, Isolated from Power Line)**

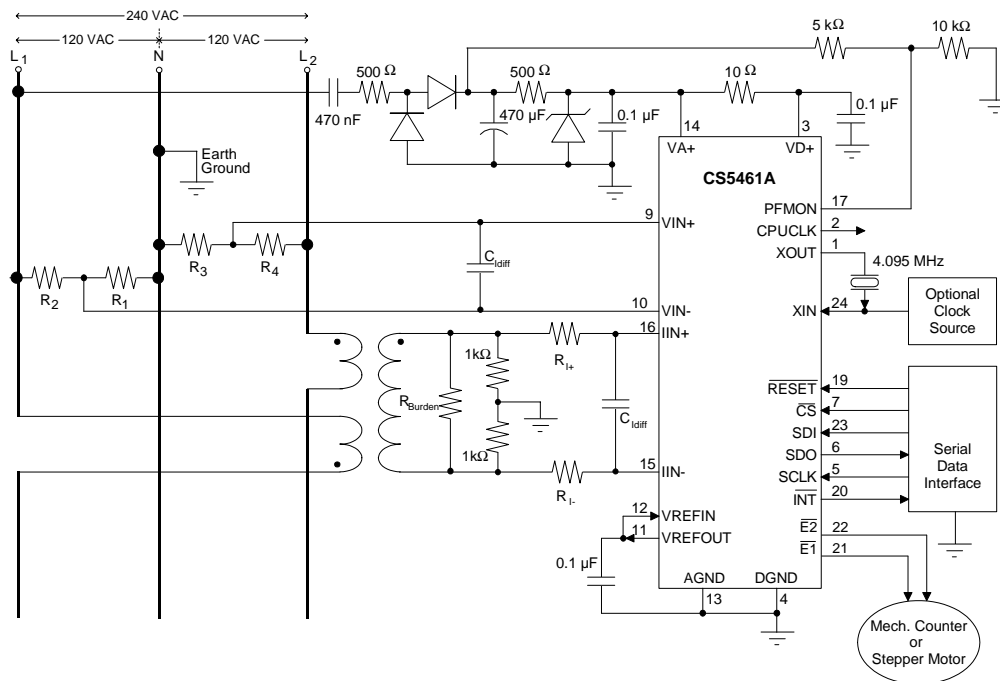

**Figure 16. Typical Connection Diagram (One-Phase 3-Wire)**

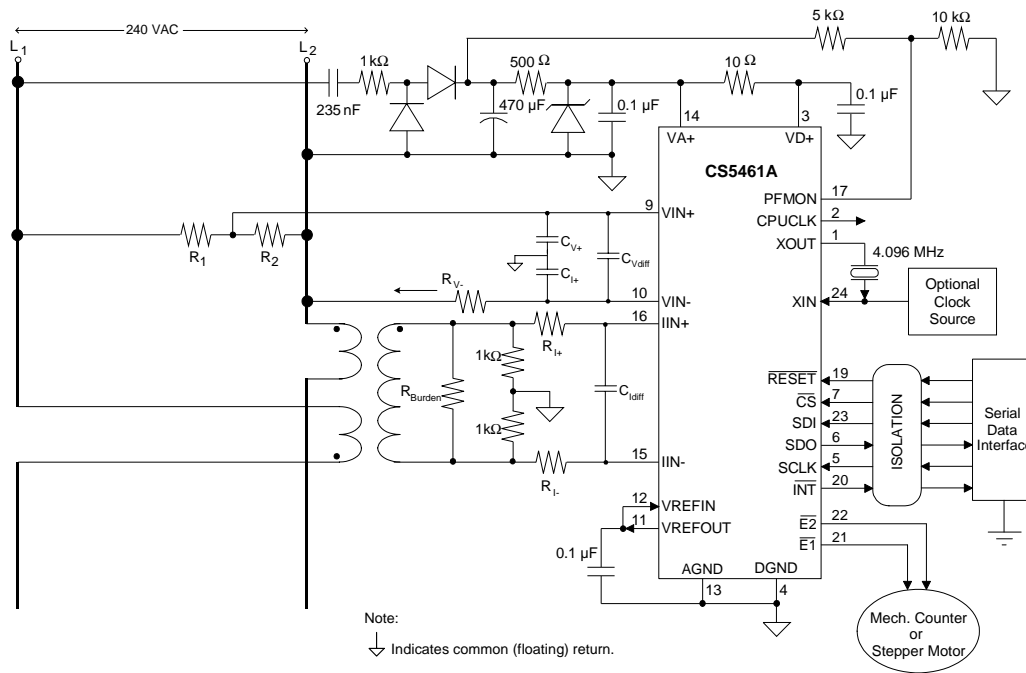

**Figure 17. Typical Connection Diagram (One-Phase 3-Wire - No Neutral Available)**

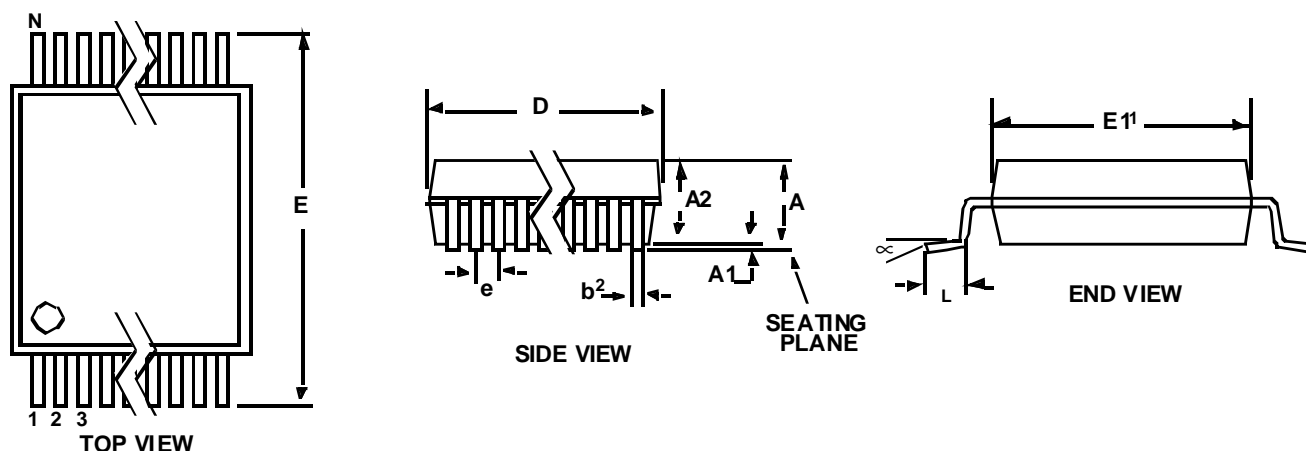
**10. PACKAGE DIMENSIONS**
**24L SSOP PACKAGE DRAWING**

DIM	INCHES			MILLIMETERS			NOTE
	MIN	NOM	MAX	MIN	NOM	MAX	
A	--	--	0.084	--	--	2.13	
A1	0.002	0.006	0.010	0.05	0.13	0.25	
A2	0.064	0.068	0.074	1.62	1.73	1.88	
b	0.009	--	0.015	0.22	--	0.38	2,3
D	0.311	0.323	0.335	7.90	8.20	8.50	1
E	0.291	0.307	0.323	7.40	7.80	8.20	
E1	0.197	0.209	0.220	5.00	5.30	5.60	1
e	0.022	0.026	0.030	0.55	0.65	0.75	
L	0.025	0.03	0.041	0.63	0.75	1.03	
∞	0°	4°	8°	0°	4°	8°	

**JEDEC #: MO-150**

Controlling Dimension is Millimeters.

- Notes:
- "D" and "E1" are reference datums and do not include mold flash or protrusions, but do include mold mismatch and are measured at the parting line, mold flash or protrusions shall not exceed 0.20 mm per side.
  - Dimension "b" does not include dambar protrusion/intrusion. Allowable dambar protrusion shall be 0.13 mm total in excess of "b" dimension at maximum material condition. Dambar intrusion shall not reduce dimension "b" by more than 0.07 mm at least material condition.
  - These dimensions apply to the flat section of the lead between 0.10 and 0.25 mm from lead tips.



## 11. REVISIONS

Revision	Date	Changes
A1	Dec. 2004	Advance Release
PP1	Feb. 2005	Initial Preliminary Release

---

### Contacting Cirrus Logic Support

For all product questions and inquiries contact a Cirrus Logic Sales Representative.

To find the one nearest to you go to [www.cirrus.com](http://www.cirrus.com)

---

#### IMPORTANT NOTICE

"Preliminary" product information describes products that are in production, but for which full characterization data is not yet available

Cirrus Logic, Inc. and its subsidiaries ("Cirrus") believe that the information contained in this document is accurate and reliable. However, the information is subject to change without notice and is provided "AS IS" without warranty of any kind (express or implied). Customers are advised to obtain the latest version of relevant information to verify, before placing orders, that information being relied on is current and complete. All products are sold subject to the terms and conditions of sale supplied at the time of order acknowledgment, including those pertaining to warranty, indemnification, and limitation of liability. No responsibility is assumed by Cirrus for the use of this information, including use of this information as the basis for manufacture or sale of any items, or for infringement of patents or other rights of third parties. This document is the property of Cirrus and by furnishing this information, Cirrus grants no license, express or implied under any patents, mask work rights, copyrights, trademarks, trade secrets or other intellectual property rights. Cirrus owns the copyrights associated with the information contained herein and gives consent for copies to be made of the information only for use within your organization with respect to Cirrus integrated circuits or other products of Cirrus. This consent does not extend to other copying such as copying for general distribution, advertising or promotional purposes, or for creating any work for resale.

CERTAIN APPLICATIONS USING SEMICONDUCTOR PRODUCTS MAY INVOLVE POTENTIAL RISKS OF DEATH, PERSONAL INJURY, OR SEVERE PROPERTY OR ENVIRONMENTAL DAMAGE ("CRITICAL APPLICATIONS"). CIRRUS PRODUCTS ARE NOT DESIGNED, AUTHORIZED OR WARRANTED FOR USE IN AIRCRAFT SYSTEMS, MILITARY APPLICATIONS, PRODUCTS SURGICALLY IMPLANTED INTO THE BODY, AUTOMOTIVE SAFETY OR SECURITY DEVICES, LIFE SUPPORT PRODUCTS OR OTHER CRITICAL APPLICATIONS. INCLUSION OF CIRRUS PRODUCTS IN SUCH APPLICATIONS IS UNDERSTOOD TO BE FULLY AT THE CUSTOMER'S RISK AND CIRRUS DISCLAIMS AND MAKES NO WARRANTY, EXPRESS, STATUTORY OR IMPLIED, INCLUDING THE IMPLIED WARRANTIES OF MERCHANTABILITY AND FITNESS FOR PARTICULAR PURPOSE, WITH REGARD TO ANY CIRRUS PRODUCT THAT IS USED IN SUCH A MANNER. IF THE CUSTOMER OR CUSTOMER'S CUSTOMER USES OR PERMITS THE USE OF CIRRUS PRODUCTS IN CRITICAL APPLICATIONS, CUSTOMER AGREES, BY SUCH USE, TO FULLY INDEMNIFY CIRRUS, ITS OFFICERS, DIRECTORS, EMPLOYEES, DISTRIBUTORS AND OTHER AGENTS FROM ANY AND ALL LIABILITY, INCLUDING ATTORNEYS' FEES AND COSTS, THAT MAY RESULT FROM OR ARISE IN CONNECTION WITH THESE USES.

Cirrus Logic, Cirrus, and the Cirrus Logic logo designs are trademarks of Cirrus Logic, Inc. All other brand and product names in this document may be trademarks or service marks of their respective owners.

SPI is a trademark of Motorola, Inc.

Microwire is a trademark of National Semiconductor Corporation.

