



STEVAL-ISV006V2

Up to 5 W solar battery charger with embedded MPPT based on the SPV1040

Data brief

Features

- High-efficiency monolithic step-up DC-DC converter
- Proprietary “perturb & observe” embedded MPPT algorithm
- Very low input voltage (down to 0.3 V)
- Integrated N-channel and P-channel MOSFETs with low R_{ON} resistance
- Overcurrent and overtemperature protection
- Input reverse polarity protection
- LED charge status indicator
- RoHS compliant

Description

The STEVAL-ISV006V2 demonstration board is based on the SPV1040 high efficiency solar battery charger with embedded MPPT. The SPV1040 device is a low power, low voltage, monolithic step-up converter with an input voltage range from 0.3 V to 5.5 V, and is capable of maximizing the energy generated by even a single solar cell (or fuel cell), where low input voltage handling capability is extremely important.

Thanks to the embedded MPPT algorithm, even under varying environmental conditions (such as irradiation, dirt, temperature) the SPV1040 offers maximum efficiency in terms of power harvested from the cells and transferred to the output.

The device employs an input voltage regulation loop, which fixes the charging battery voltage via a resistor divider. The maximum output current is set with a current sense resistor according to charging current requirements.

The SPV1040 protects itself and other application devices by stopping the PWM switching if either the maximum current threshold (up to 2 A) is reached or the maximum temperature limit (up to 155 °C) is exceeded.



The STEVAL-ISV006V2 demonstration board is supplied by a PV panel with P_{PK} of 200 mW, which can be replaced with PV panels with P_{PK} up to 5 W ($V_{OC} < 5$ V) depending on application requirements.

The output load is a 220 mF, 5.5 V super-capacitor that can be replaced with lead-acid, NiCd or NiMh rechargeable batteries (max voltage = 5 and $> V_{OC}$ of the selected PV panel).

The demonstration board provides a simple charge status indicator using 2 LEDs, and 3 trimmers are available to allow setup according to the specific application requirements.

1 Schematic diagram

Figure 1. STEVAL-ISV006V2 circuit schematic

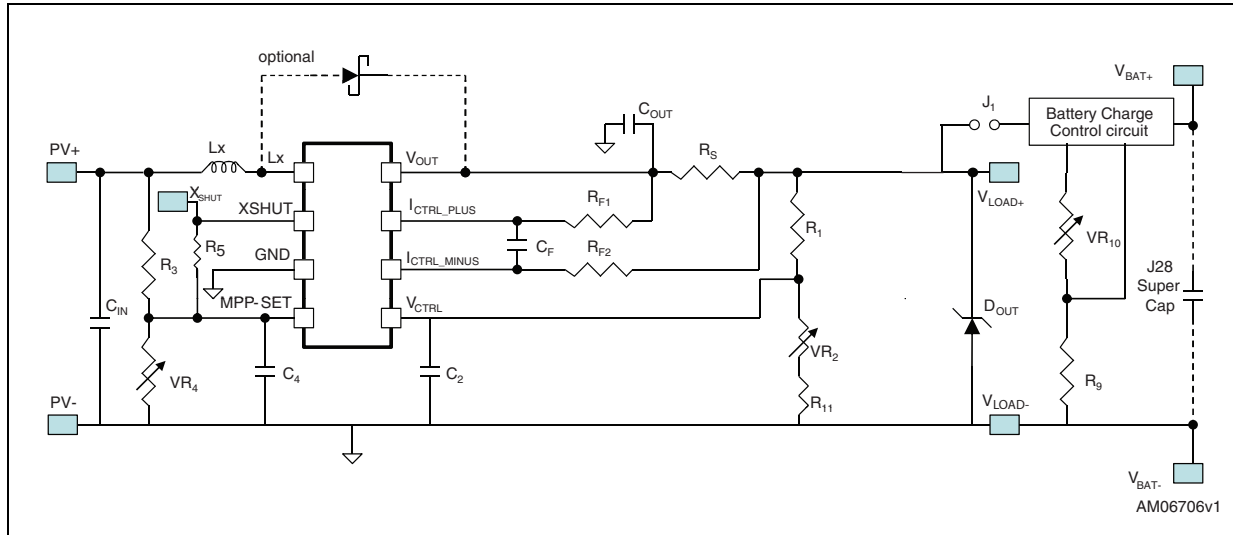

2 Revision history

Table 1. Document revision history

Date	Revision	Changes
25-Mar-2011	1	Initial release.
05-May-2011	2	Updated: Figure 1: STEVAL-ISV006V2 circuit schematic.
11-Oct-2011	3	Updated: figure of the board in cover page

Please Read Carefully:

Information in this document is provided solely in connection with ST products. STMicroelectronics NV and its subsidiaries ("ST") reserve the right to make changes, corrections, modifications or improvements, to this document, and the products and services described herein at any time, without notice.

All ST products are sold pursuant to ST's terms and conditions of sale.

Purchasers are solely responsible for the choice, selection and use of the ST products and services described herein, and ST assumes no liability whatsoever relating to the choice, selection or use of the ST products and services described herein.

No license, express or implied, by estoppel or otherwise, to any intellectual property rights is granted under this document. If any part of this document refers to any third party products or services it shall not be deemed a license grant by ST for the use of such third party products or services, or any intellectual property contained therein or considered as a warranty covering the use in any manner whatsoever of such third party products or services or any intellectual property contained therein.

UNLESS OTHERWISE SET FORTH IN ST'S TERMS AND CONDITIONS OF SALE ST DISCLAIMS ANY EXPRESS OR IMPLIED WARRANTY WITH RESPECT TO THE USE AND/OR SALE OF ST PRODUCTS INCLUDING WITHOUT LIMITATION IMPLIED WARRANTIES OF MERCHANTABILITY, FITNESS FOR A PARTICULAR PURPOSE (AND THEIR EQUIVALENTS UNDER THE LAWS OF ANY JURISDICTION), OR INFRINGEMENT OF ANY PATENT, COPYRIGHT OR OTHER INTELLECTUAL PROPERTY RIGHT.

UNLESS EXPRESSLY APPROVED IN WRITING BY TWO AUTHORIZED ST REPRESENTATIVES, ST PRODUCTS ARE NOT RECOMMENDED, AUTHORIZED OR WARRANTED FOR USE IN MILITARY, AIR CRAFT, SPACE, LIFE SAVING, OR LIFE SUSTAINING APPLICATIONS, NOR IN PRODUCTS OR SYSTEMS WHERE FAILURE OR MALFUNCTION MAY RESULT IN PERSONAL INJURY, DEATH, OR SEVERE PROPERTY OR ENVIRONMENTAL DAMAGE. ST PRODUCTS WHICH ARE NOT SPECIFIED AS "AUTOMOTIVE GRADE" MAY ONLY BE USED IN AUTOMOTIVE APPLICATIONS AT USER'S OWN RISK.

Resale of ST products with provisions different from the statements and/or technical features set forth in this document shall immediately void any warranty granted by ST for the ST product or service described herein and shall not create or extend in any manner whatsoever, any liability of ST.

ST and the ST logo are trademarks or registered trademarks of ST in various countries.

Information in this document supersedes and replaces all information previously supplied.

The ST logo is a registered trademark of STMicroelectronics. All other names are the property of their respective owners.

© 2011 STMicroelectronics - All rights reserved

STMicroelectronics group of companies

Australia - Belgium - Brazil - Canada - China - Czech Republic - Finland - France - Germany - Hong Kong - India - Israel - Italy - Japan - Malaysia - Malta - Morocco - Philippines - Singapore - Spain - Sweden - Switzerland - United Kingdom - United States of America

www.st.com