HD74LVCZ16244A

16-bit Buffers / Line Drivers with 3-state Outputs

HITACHI

ADE-205-232 (Z)
1st. Edition
February 1999

Description

The HD74LVCZ16244A has sixteen line drivers with three state outputs in a 48 pin package. This device is a non inverting buffer and has four active low enables (1 \bar{G} to 4 \bar{G}). Each enable independently controls four buffers.

When V_{CC} is between 0 and 1.5 V, the device is in the high impedance state during power up or power down.

Low voltage and high speed operation is suitable at battery drive product (note type personal computer) and low power consumption extends the life of a battery for long time operation.

Features

- $V_{CC} = 2.7$ to 5.5 V
- All inputs V_{IH} (Max) = 5.5 V (@ $V_{CC} = 0$ to 5.5 V)
- All outputs V_O (Max) = 5.5 V (@ $V_{CC} = 0$ V or output off state)
- Typical V_{OL} ground bounce < 0.8 V (@ $V_{CC} = 3.3$ V, $T_a = 25^\circ\text{C}$)
- Typical V_{OH} undershoot > 2.0 V (@ $V_{CC} = 3.3$ V, $T_a = 25^\circ\text{C}$)
- High impedance state during power up and power down
- Power off disables outputs, permitting live insertion
- High output current ± 24 mA (@ $V_{CC} = 3.0$ to 5.5 V)

HD74LVCZ16244A

Function Table

Inputs		Output Y
$\overline{\text{G}}$	A	
H	X	Z
L	H	H
L	L	L

H : High level

L : Low level

X : Immaterial

Z : High impedance

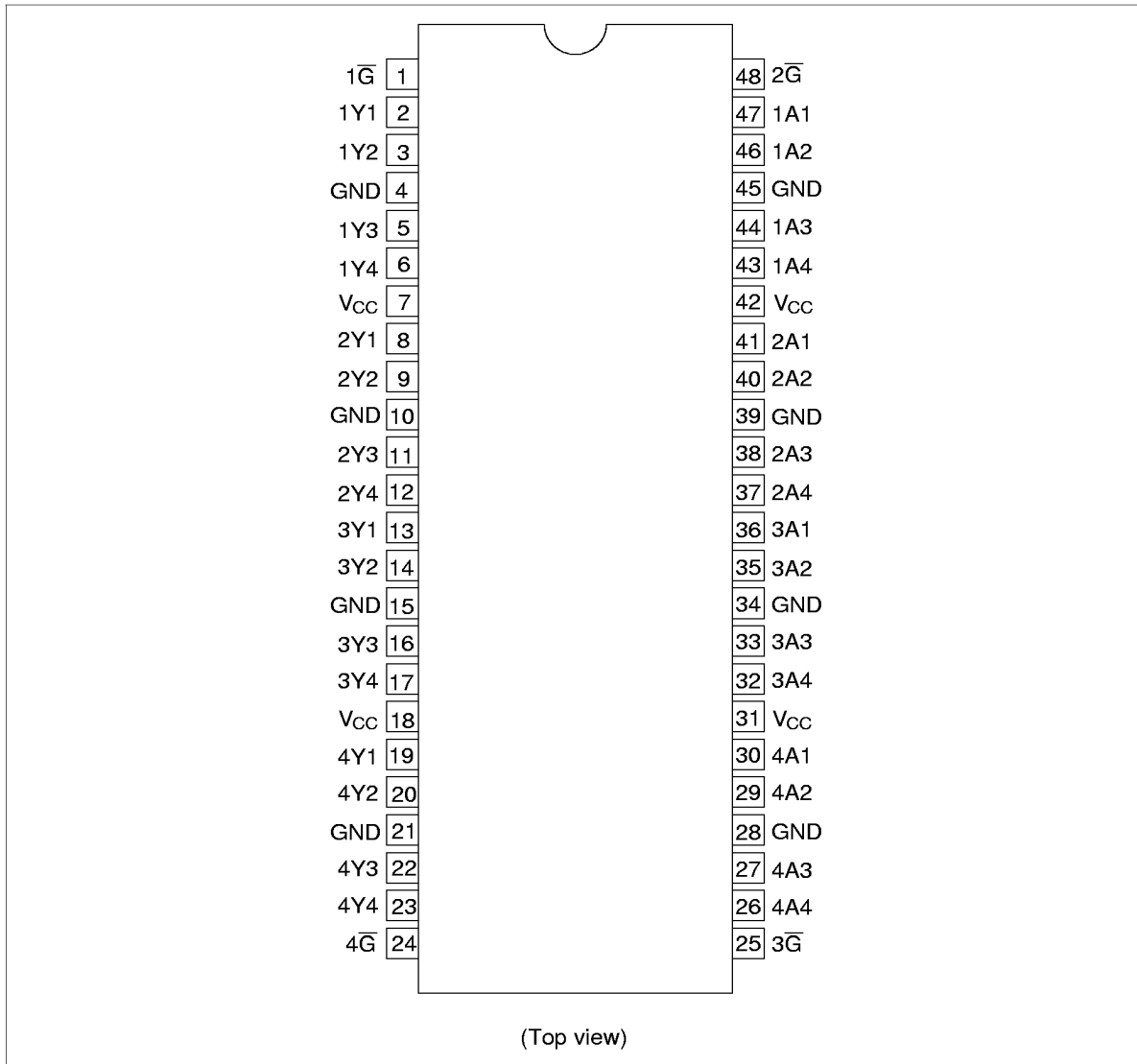
Pin Arrangement

HD74LVCZ16244A

Absolute Maximum Ratings

Item	Symbol	Ratings	Unit	Conditions
Supply voltage	V_{CC}	-0.5 to 7.0	V	
Input voltage	V_I	-0.5 to 7.0	V	
Output voltage	V_O	-0.5 to 7.0 -0.5 to $V_{CC}+0.5$	V	Output "Z" or V_{CC} : OFF Output "H" or "L"
Input diode current	I_{IK}	-50	mA	$V_I < 0$
Output diode current	I_{OK}	-50	mA	$V_O < 0$
Output current	I_O	± 50	mA	
V_{CC} , GND current	I_{CC} or I_{GND}	± 100	mA	
Storage temperature	Tstg	-65 to 150	°C	

Note: The absolute maximum ratings are values which must not individually be exceeded, and furthermore, no two of which may be realized at the same time.

Recommended Operating Conditions

Item	Symbol	Ratings	Unit	Conditions
Supply voltage	V_{CC}	2.7 to 5.5	V	At operation
Input voltage	V_I	0 to 5.5	V	
Output voltage	V_O	0 to 5.5 0 to V_{CC}	V	Output "Z" or V_{CC} : OFF Output "H" or "L"
Output current	I_{OH}	-12 -24 ¹⁾	mA	$V_{CC} = 2.7$ V $V_{CC} = 3.0$ to 5.5 V
	I_{OL}	12 24 ¹⁾		$V_{CC} = 2.7$ V $V_{CC} = 3.0$ to 5.5 V
Input rise / fall time	t_r, t_f	0 to 6	ns / V	
Operating temperature	Ta	-40 to +85	°C	

Note: 1. Duty cycle $\leq 50\%$

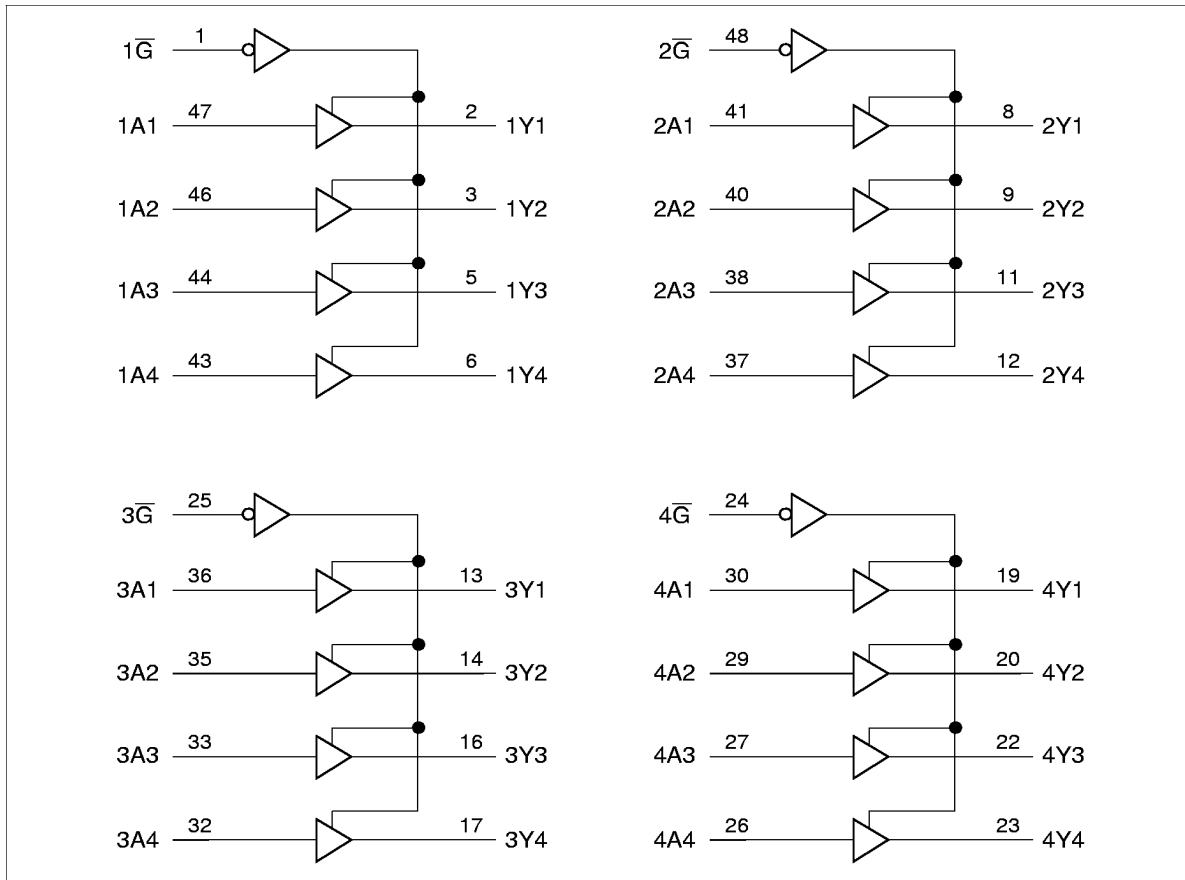
Logic Diagram

HD74LVCZ16244A

Electrical Characteristics (Ta = -40 to 85°C)

Item	Symbol	V _{CC} (V)	Min	Typ	Max	Unit	Test Conditions
Input voltage	V _{IH}	2.7 to 3.6	2.0	—	—	V	
		4.5 to 5.5	V _{CC} ×0.7	—	—		
	V _{IL}	2.7 to 3.6	—	—	0.8		
		4.5 to 5.5	—	—	V _{CC} ×0.3		
Output voltage	V _{OH}	2.7 to 5.5	V _{CC} -0.2	—	—	V	I _{OH} = -100 μA
		2.7	2.2	—	—		I _{OH} = -12 mA
		3.0	2.4	—	—		
		3.0	2.2	—	—		I _{OH} = -24 mA
		4.5	3.8	—	—		
	V _{OL}	2.7 to 5.5	—	—	0.2	I _{OL} = 100 μA	
		2.7	—	—	0.4	I _{OL} = 12 mA	
		3.0	—	—	0.55	I _{OL} = 24 mA	
		4.5	—	—	0.55		
	Input current	I _{IN}	0 to 5.5	—	—	±5	μA
Off state output current	I _{OZ}	2.7 to 5.5	—	—	±5	μA	V _{OUT} = 0 to 5.5 V
	I _{OZPU}	0 to 1.5	—	—	±5		V _{OUT} = 0.5 to 5.5 V,
	I _{OZPD}	1.5 to 0	—	—	±5		Output enable = don't care
Output leak current	I _{OFF}	0	—	—	±5	μA	V _{IN} or V _O = 5.5 V
Quiescent supply current	I _{CC}	2.7 to 3.6	—	—	225	μA	V _{IN} = 3.6 to 5.5 V ¹ , I _O = 0
		2.7 to 5.5	—	—	350		V _{IN} = V _{CC} or GND
	ΔI _{CC}	2.7 to 3.6	—	—	500		V _{IN} = one input at (V _{CC} -0.6) V, other inputs at V _{CC} or GND
Input capacitance	C _{IN}	3.3	—	4.1	—	pF	V _{IN} = V _{CC} or GND
Output capacitance	C _O	3.3	—	8.1	—	pF	V _{OUT} = V _{CC} or GND

Note: 1. This applies in the disabled state only.

HD74LVCZ16244A

Switching Characteristics (Ta = -40 to 85°C)

Item	Symbol	V _{CC} (V)	Min	Typ	Max	Unit	FROM (Input)	TO (Output)
Propagation delay time	t _{PLH}	2.7	—	—	4.7	ns	A	Y
	t _{PHL}	3.3±0.3	1.1	—	4.1			
		5.0±0.5	—	—	3.8			
Output enable time	t _{ZH}	2.7	—	—	5.8	ns	\bar{G}	Y
	t _{ZL}	3.3±0.3	1.0	—	4.6			
		5.0±0.5	—	—	4.4			
Output disable time	t _{HZ}	2.7	—	—	6.2	ns	\bar{G}	Y
	t _{LZ}	3.3±0.3	1.8	—	5.8			
		5.0±0.5	—	—	4.6			
Between output pin skew ¹	t _{OSLH}	2.7	—	—	—	ns		
	t _{OSHL}	3.3±0.3	—	—	1.0			
		5.0±0.5	—	—	1.0			

Note : 1. This parameter is characterized but not tested.

$$t_{OSLH} = |t_{PLHm} - t_{PLHn}|, t_{OSHL} = |t_{PHLm} - t_{PHLn}|$$

Test Circuit

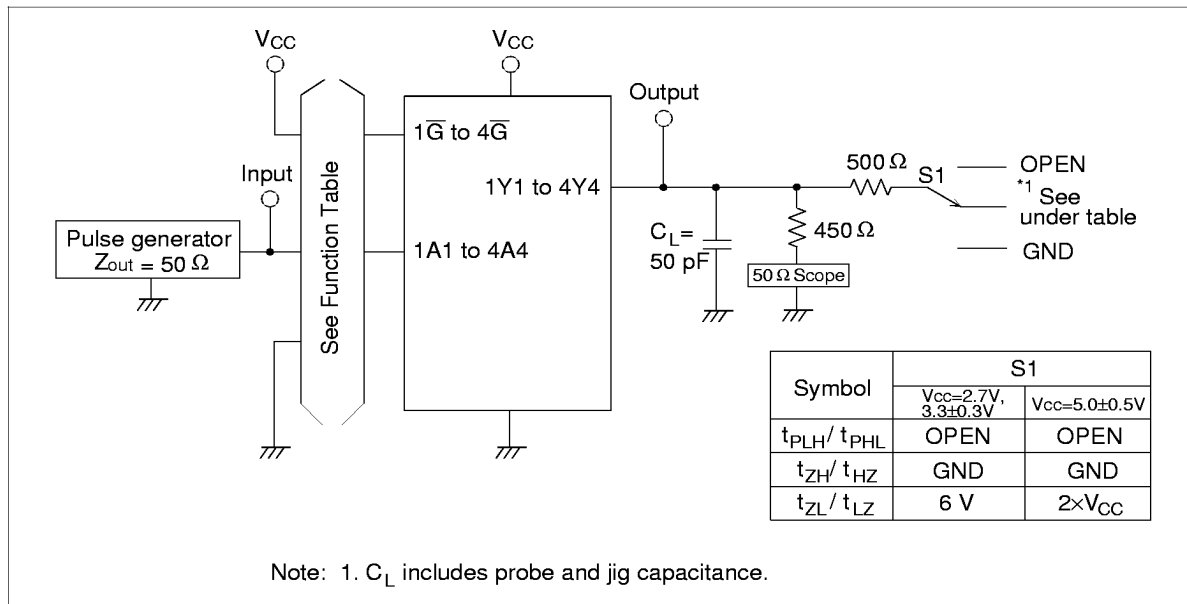

HD74LVCZ16244A

• Waveforms – 1

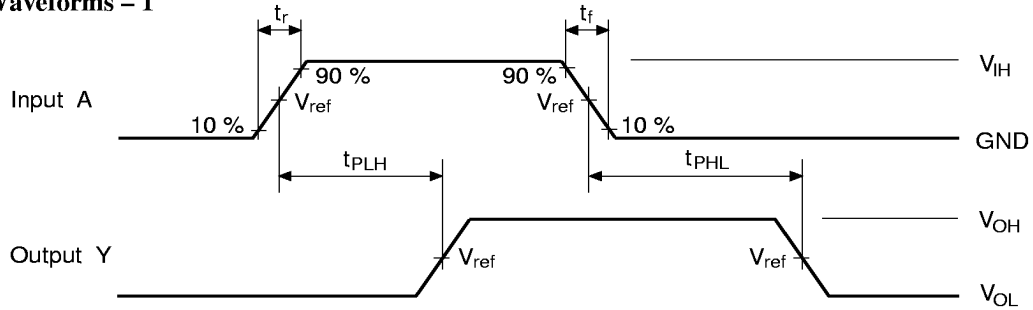

• Waveforms – 2

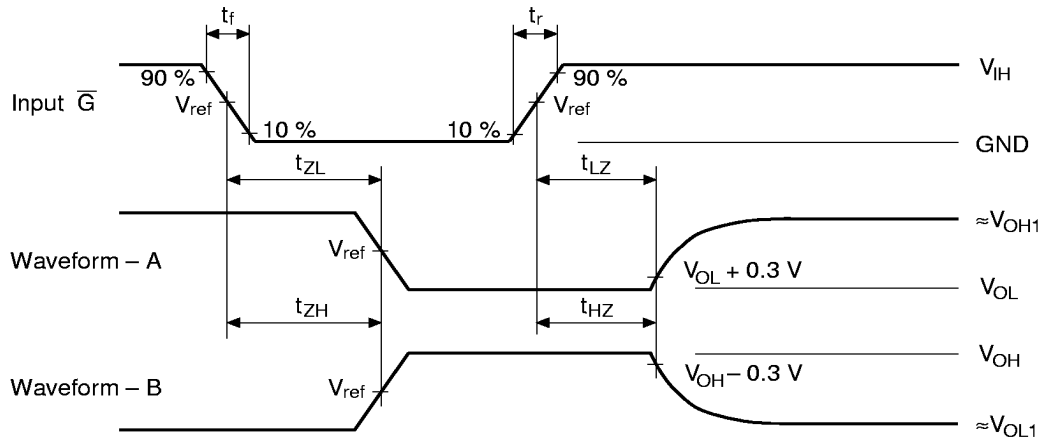

TEST	$V_{CC}=2.7V, 3.3\pm 0.3V$	$V_{CC}=5.0\pm 0.5V$
V_{IH}	2.7 V	V_{CC}
V_{ref}	1.5 V	$50\%V_{CC}$
V_{OH1}	3 V	V_{CC}
V_{OL1}	GND	GND

- Notes: 1. Input waveform : PRR = 10 MHz, duty cycle 50%, $t_r = 2.5$ ns, $t_f = 2.5$ ns
 2. Waveform - A shows input conditions such that the output is "L" level when enabled by the output control.
 3. Waveform - B shows input conditions such that the output is "H" level when enabled by the output control.

Power up / down Characteristics

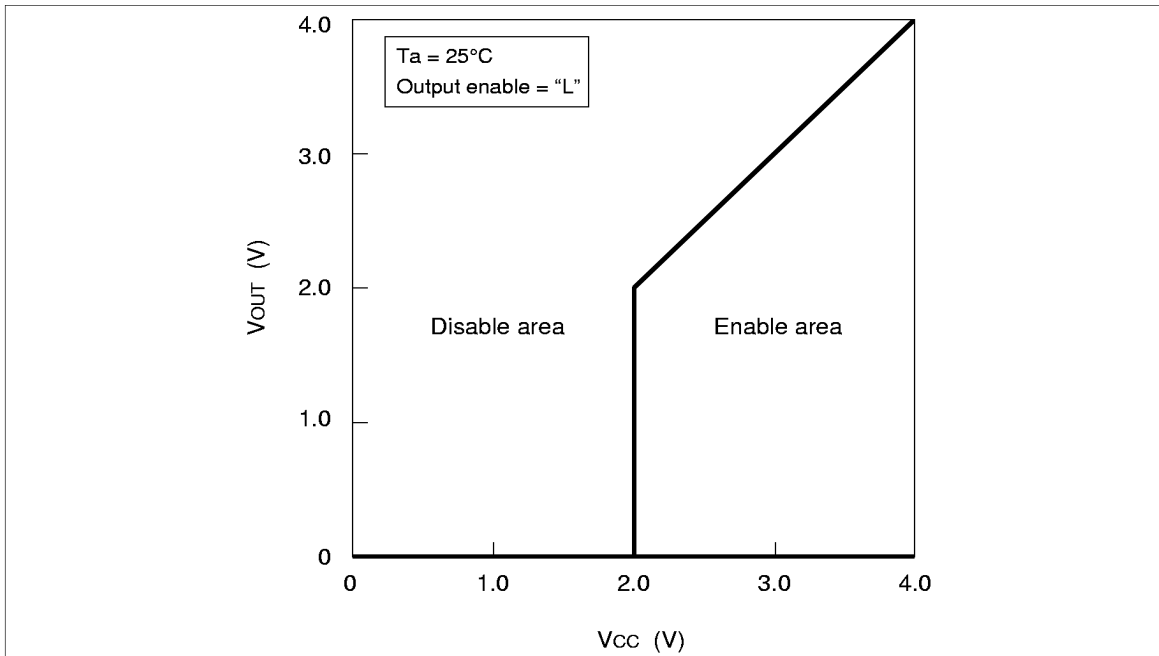

HD74LVCZ16244A

Package Dimensions

Unit : mm

