

2N5679 – 2N5680

PNP SWITCHING TRANSISTORS

The 2N5679 and 2N5680 are silicon epitaxial planar PNP transistors in jedec TO-39 metal case. They are intended for use as drivers for high power transistors in general purpose, amplifier and switching circuit. The complementary NPN types are the 2N5681 and 2N5682 . Compliance to RoHS.

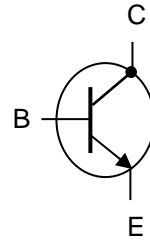

ABSOLUTE MAXIMUM RATINGS

Symbol	Ratings		Value		Unit
			25679	2N5680	
V_{CEO}	Collector-Emitter Voltage	$I_B = 0$	-100	-120	V
V_{CBO}	Collector-Base Voltage	$I_E = 0$	-100	-120	V
V_{EBO}	Emitter-Base Voltage	$I_C = 0$	-4		V
I_C	Collector Current		-1		A
I_B	Base Current		-500		mA
P_D	Total Power Dissipation	$T_{amb} = 25^\circ\text{C}$	1		W
		$T_{case} = 25^\circ\text{C}$	10		
T_J	Junction Temperature		200		$^\circ\text{C}$
T_{Stg}	Storage Temperature range		-65 to +150		

THERMAL CHARACTERISTICS

Symbol	Ratings	Value	Unit
R_{thJ-a}	Thermal Resistance, Junction to ambient	175	$^\circ\text{C/W}$
R_{thJ-c}	Thermal Resistance, Junction to case	17.5	$^\circ\text{C/W}$

2N5679 – 2N5680

ELECTRICAL CHARACTERISTICS

T_j=25°C unless otherwise specified

Symbol	Ratings	Test Condition(s)	Min	Typ	Mx	Unit					
I _{CBO}	Collector Cutoff Current	V _{CB} = -100 V, I _E = 0	2N5679	-	-	-1	μA				
		V _{CB} = -120 V, I _E = 0	2N5680								
I _{CEO}	Collector Cutoff Current	V _{CE} = -70 V, I _B = 0	2N5679	-	-	-10	μA				
		V _{CE} = -80 V, I _B = 0	2N5680								
I _{CEV}	Collector Cutoff Current	V _{CE} = -100 V, V _{BE} = 1.5 V	2N5679	-	-	-1	μA				
		V _{CE} = -120 V, V _{BE} = 1.5 V	2N5680								
		V _{CE} = -100 V, V _{BE} = 1.5 V T _C = 150°C	2N5679					-	-	-1	mA
		V _{CE} = -120 V, V _{BE} = 1.5 V T _C = 150°C	2N5680								
I _{EBO}	Emitter Cutoff Current	V _{BE} = -4.0 V, I _C = 0	2N5679	-	-	-1	μA				
			2N5680								
V _{CEO(sus)}	Collector Emitter Sustaining voltage (*)	I _C = -10 mA, I _B = 0	2N5679	-100	-	-	V				
			2N5680					-120			
V _{CE(SAT)}	Collector-Emitter saturation Voltage (*)	I _C = -250 mA I _B = -25 mA	2N5679	-	-	-0.6	V				
			2N5680								
		I _C = -500 mA I _B = -50 mA	2N5679					-	-	-1	
			2N5680								
I _C = -1 A I _B = -200 mA	2N5679	-	-	-2							
	2N5680										
V _{BE}	Base-Emitter Voltage (*)	I _C = -250 mA, V _{CE} = -2 V	2N5679	-	-	-1	V				
			2N5680								
h _{FE}	DC Current Gain (*)	I _C = -250 mA, V _{CE} = -2 V	2N5679	40	-	150	V				
			2N5680								
		I _C = -1 A, V _{CE} = -2 V	2N5679	5	-	-					
			2N5680								
f _T	Transition frequency	I _C = -100 mA, V _{CE} = -10 V f = 10 MHz	2N5679	30	-	-	MHz				
			2N5680								
C _{OB}	Output Capacitance	I _E = 0, V _{CB} = -20 V f = 1MHz	2N5679	-	-	50	pF				
			2N5680								
h _{fe}	Small Signal Current Gain	I _C = -200 mA, V _{CE} = -1.5 V f = 1 kHz	2N5679	40	-	-	-				
			2N5680								

(*) Pulse Width ≈ 300 μs, Duty Cycle < 2.0%

2N5679 – 2N5680

MECHANICAL DATA CASE TO-39

DIMENSIONS (mm)		
	min	max
A	8.50	9.39
B	7.74	8.50
C	6.09	6.60
D	0.40	0.53
E	-	0.88
F	2.41	2.66
G	4.82	5.33
H	0.71	0.86
J	0.73	1.02
K	12.70	-
L	42°	48°

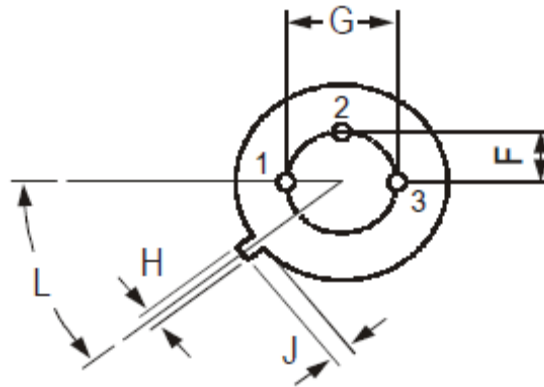
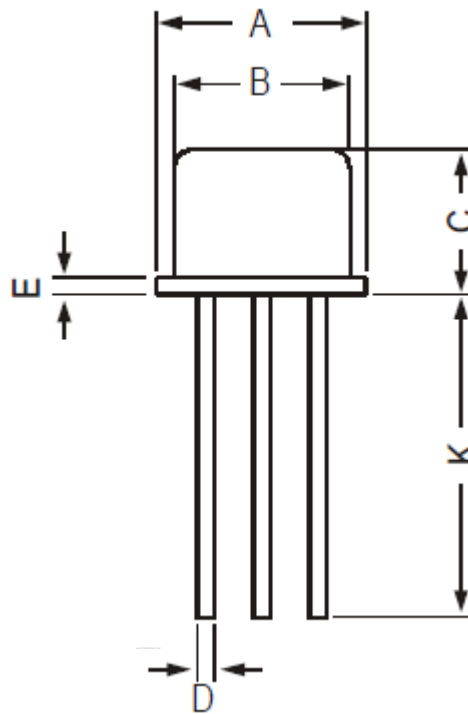

Pin 1 :	Emitter
Pin 2 :	Base
Pin 3 :	Collector
Case :	Collector

Revised August 2012

Information furnished is believed to be accurate and reliable. However, Comset Semiconductors assumes no responsibility for the consequences of use of such information nor for any infringement of patents or other rights of third parties which may result from its use. Data are subject to change without notice. Comset Semiconductors makes no warranty, representation or guarantee regarding the suitability of its products for any particular purpose, nor does Comset Semiconductors assume any liability arising out of the application or use of any product and specifically disclaims any and all liability, including without limitation consequential or incidental damages. Comset Semiconductors' products are not authorized for use as critical components in life support devices or systems.