

### Description

The GM6655 series is a low-dropout linear regulator. This series is specially designed for battery-operated systems. The ground current is very low (50µA Typ), that significantly extending battery life. Low power consumption and high accuracy is achieved through CMOS and programmable fuse technologies with the output voltage range from 1.5V to 6.0V.

The GM6655 consists of a high-precision voltage reference, an error correction circuit, and a current limited output driver. With good transient responses, output remains stable even during load changes. The SHDN input enables the output to be turned off, resulting in reduced power consumption.

Also, the GM6655 having high ripple rejection ratios, the series can be used with power supply noise. A 470pF capacitor from the bypass input to ground reduces noise present on the internal reference, which in turn significantly reduces output noise. If output noise is not a concern, this input may be left unconnected. Larger capacitor values  $C_{bp}$  be used, but results in a longer time period to rated output voltage when power is initially applied.

The GM6655 incorporates both over-temperature and over-current protection.

### Features

- ◆ Maximum output current up 600mA
- ◆ Highly accurate output voltage: ±1.5%
- ◆ Low power consumption
- ◆ On-chip protections: Thermal, and Short Circuit
- ◆ Small input/output differential: 600mV at 600mA

### Application

- Battery Operated Systems
- Portable Computers
- Portable Caremas and Video Recorders

- Reference Voltage Sources
- Instruments
- Pagers

### Typical Application Circuits

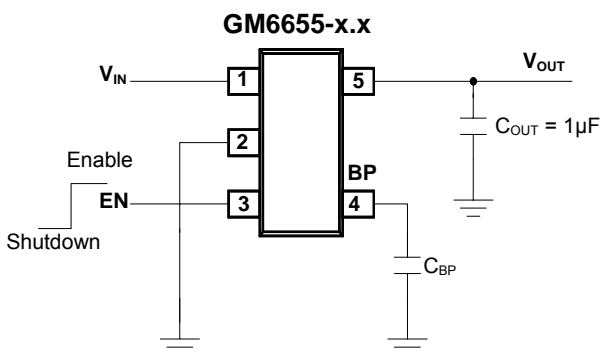

Figure 1 Fixed output version

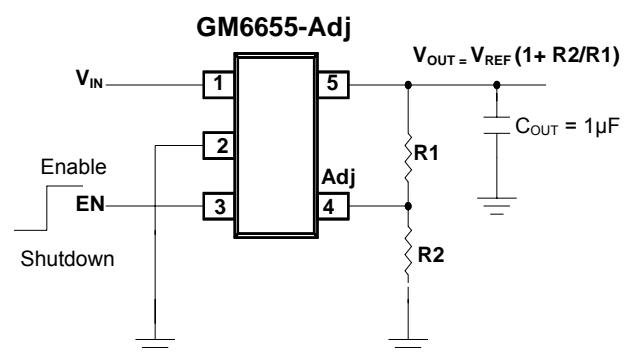
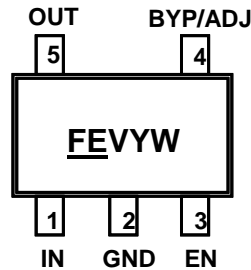

Figure 2. Adjustable output version

Note: EN (Pin 3) maybe connected directly to  $V_{IN}$  (Pin1)

### Marking Information and Pin Configurations (Top View)

SOT25



FE: Device Code, Green Product  
 V: Voltage Code (see next page)  
 Y: Year  
 W: Week code

### Pin Descriptions

Pin Number	Pin Name	Pin Function	
1	IN	Supply Input	
2	GND	Ground	
3	EN	Enable/Shutdown (Input): CMOS compatible input. Logic high = Enable; logic low or open = shutdown	
4	Fixed output	BYP	Reference Bypass: Connect external 470pF capacitor to GND to reduce output noise. May be left open.
	Adjustable output	ADJ	Adjust (Input): Adjustable regulator feedback input. Connect to resistor voltage divider
5	OUT	Regulator Output	

### Ordering Information

Ordering Number	Output Voltage	Voltage Code	Package	Shipping
GM6655-AST25RG	Adj	A	SOT-25	3,000 Units/Tape and Reel
GM6655-1.8ST25RG	1.8V	E	SOT-25	3,000 Units/Tape and Reel
GM6655-2.0ST25RG	2.0V	F	SOT-25	3,000 Units/Tape and Reel
GM6655-2.5ST25RG	2.5V	G	SOT-25	3,000 Units/Tape and Reel
GM6655-2.7ST25RG	2.7V	T	SOT-25	3,000 Units/Tape and Reel
GM6655-2.8ST25RG	2.8V	H	SOT-25	3,000 Units/Tape and Reel
GM6655-2.9ST25RG	2.9V	X	SOT-25	3,000 Units/Tape and Reel
GM6655-3.0ST25RG	3.0V	J	SOT-25	3,000 Units/Tape and Reel
GM6655-3.3ST25RG	3.3V	K	SOT-25	3,000 Units/Tape and Reel
GM6655-3.6ST25RG	3.6V	L	SOT-25	3,000 Units/Tape and Reel
GM6655-4.0ST25RG	4.0V	M	SOT-25	3,000 Units/Tape and Reel
GM6655-4.2ST25RG	4.2V	Y	SOT-25	3,000 Units/Tape and Reel
GM6655-5.0ST25RG	5.0V	Q	SOT-25	3,000 Units/Tape and Reel

### Absolute Maximum Ratings

PARAMETER	SYMBOL	RATINGS	UNITS
Input Voltage	$V_{IN}$	7	V
Output Current	$I_{OUT}$	600	mA
Output Voltage	$V_{OUT}$	$V_{SS} - 0.3$ to $V_{IN} + 0.3$	V
Continuous Total Power Dissipation	$P_D$	300	mW
Operating Ambient Temperature	$T_A$	- 40 to 125	
Storage Temperature	$T_{stg}$	- 65 to 150	
Lead Temperature (Soldering, 10 sec)		+ 260	

### Block Diagram

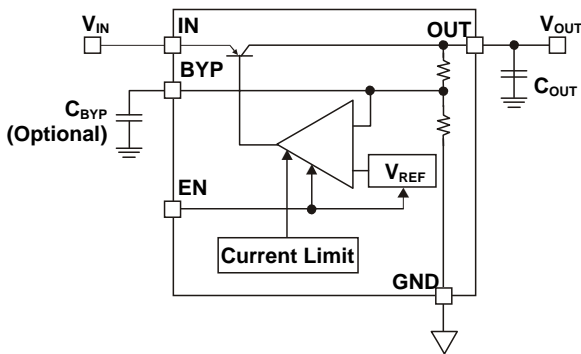

Ultra Low Noise Fixed Regulator

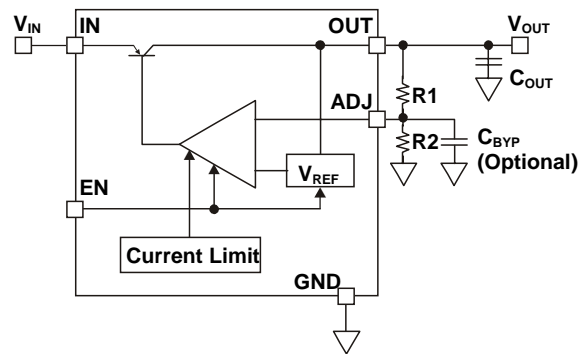

Ultra Low Noise Adjustable Regulator

$$V_{OUT} = V_{REF} (1 + R2/R1)$$

### Electrical Characteristics ( $T_A = 25^\circ\text{C}$ , $V_{IN} = V_{OUT} + 1\text{V}$ unless otherwise noted)

Parameter	Symbol	Condition	Min	Typ	Max	Unit	
Output Voltage Accuracy, Note 2		$I_{OUT} = 1\text{mA}$ ,	-1.5		+1.5	%	
		$I_{OUT} = 1$ to $600\text{mA}$ ,	-3.0		+3.0		
Line Regulation	$\Delta V_{OI}$	$I_{OUT} = 1\text{mA}$ , $V_{OUT} + 0.1\text{V} < V_{IN} < 6.5\text{V}$ Figure 3	-0.3	0.05	0.3	%/V	
Load Regulation, Note 1	$\Delta V_{OL}$	$1\text{mA} < I_{OUT} < 600\text{mA}$ $C_{OUT} = 1\mu\text{F}$ Figure 4		0.01	0.04	%/mA	
Dropout Voltage	$\Delta V$	$I_{OUT} = 600\text{mA}$	$V_{OUT} > 2.8\text{V}$		0.6	1.0	V
			$2.0\text{V} < V_{OUT} < 2.8\text{V}$		0.9	1.4	
			$V_{OUT} < 2.0\text{V}$		1.3	1.9	
Maximum Output Current	$I_{OUTMAX}$	$V_{OUT} > 0.96XV_{Rating}$	600			mA	
Output Current Limit	$I_{CL}$		500	1,300		mA	
Quiescent Current	$I_{Q2}$	$V_{EN} = V_{IN}$ , $I_{OUT} = 1$ to $600\text{mA}$ , Figure 5		50	85	$\mu\text{A}$	
		$V_{EN} = \text{Gnd}$ (Shutdwon)		0.001	1	$\mu\text{A}$	
EN Exit Delay	$T_{DLY}$	$C_{BP} = 0\mu\text{F}$ , $C_{OUT} = 1\mu\text{F}$ , $I_{OUT} = 100\text{mA}$		600		$\mu\text{sec}$	
EN Input Bias Current	$I_{BH}$	$V_{EN} = V_{IN}$			100	nA	
EN Input Low Current	$I_{BL}$	$V_{EN} = \text{Gnd}$	-1	-3		$\mu\text{A}$	
EN Input Threshold Low	$V_{THL}$				0.4	V	
EN Input Threshold High	$V_{THH}$		2			V	
Power Supply Rejection Ration	PSRR	10kHz		55		dB	

Note 1: Load Regulation is measured using pulse techniques with duty cycle  $< 5\%$

Note 2: The nominal value of reference voltage for adjustable version is 1.27V

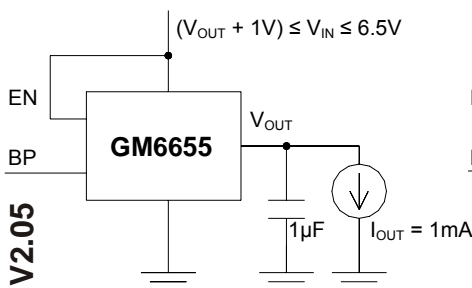

Fig 3. Line Regulation

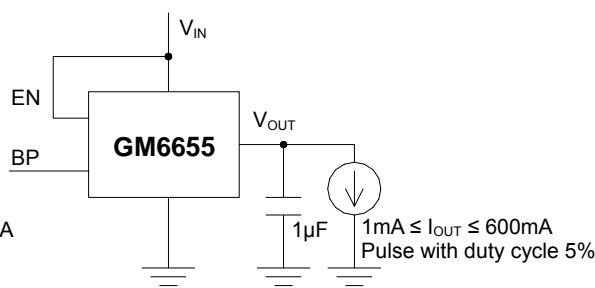

Fig 4. Load Regulation

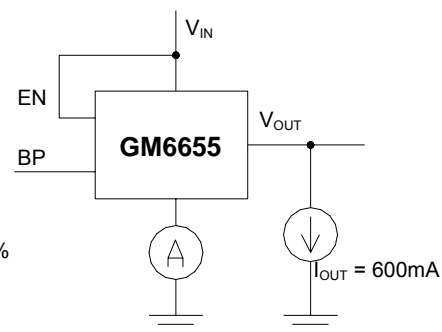

Fig 5. Load Regulation

### Typical Performance Characteristics

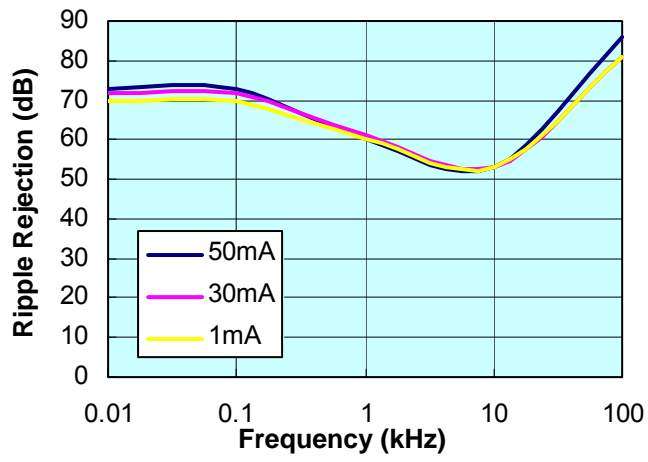
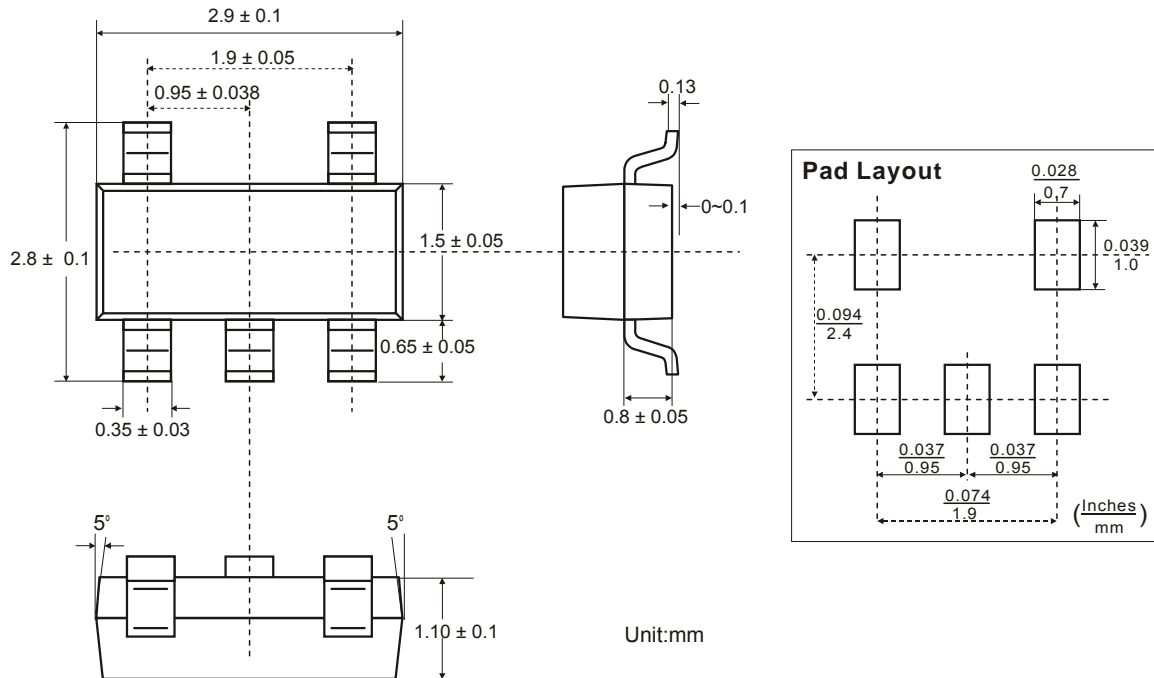

Fig 6. PSRR vs. Frequency

### Package Outline Dimensions – SOT 25



### Ordering Number

<u>GM</u>	<u>6655</u>	-	<u>1.8</u>	<u>ST25</u>	<u>R</u>	<u>G</u>
APM Gamma Micro	Circuit Type		Output Voltage	Package Type	Shipping Type	
			1.8 = 1.8V 2.0 = 2.0V 2.5 = 2.5V 3.3 = 3.3V 5.0 = 5.0V A=adj	ST25: SOT 25	R: Tape & Reel	Blank: Pb-free G:Green

Note:

#### Pb-free products:

- ◆ RoHS compliant and compatible with the current requirements of IPC/JEDEC J-STD-020.
- ◆ Suitable for use in SnPb or Pb-free soldering processes with 100% matte tin (Sn) plating.

#### Green products:

- ◆ Lead-free (RoHS compliant)
- ◆ Halogen free (Br or Cl does not exceed 900ppm by weight in homogeneous material and total of Br and Cl does not exceed 1500ppm by weight)