

MB8116160A-60/-70

CMOS 1M X 16BIT FAST PAGE MODE DYNAMIC RAM

CMOS 1,048,576 x 16BIT Fast Page Mode Dynamic RAM

The Fujitsu MB8116160A is a fully decoded CMOS Dynamic RAM (DRAM) that contains 16,777,216 memory cells accessible in 16-bit increments. The MB8116160A features a "fast page" mode of operation whereby high-speed random access of up to 256-bits of data within the same row can be selected. The MB8116160A DRAM is ideally suited for mainframe, buffers, hand-held computers video imaging equipment, and other memory applications where very low power dissipation and high bandwidth are basic requirements of the design. Since the standby current of the MB8116160A is very small, the device can be used as a non-volatile memory in equipment that uses batteries for primary and/or auxiliary power.

The MB8116160A is fabricated using silicon gate CMOS and Fujitsu's advanced four-layer polysilicon and two-layer aluminum process. This process, coupled with advanced stacked capacitor memory cells, reduces the possibility of soft errors and extends the time interval between memory refreshes. Clock timing requirements for the MB8116160A are not critical and all inputs are TTL compatible.

PRODUCT LINE & FEATURES

Parameter		MB8116160A -60	MB8116160A -70
RAS Access Time		60ns max.	70ns max.
Random Cycle Time		110ns min.	130ns min.
Address Access Time		30ns max.	35ns max.
CAS Access Time		15ns max.	17ns max.
Fast Page Mode Cycle Time		40ns min.	45ns min.
Low Power Dissipation	Operating current	550mW max.	495mW max.
	Standby current	11mW max. (TTL level) / 5.5mW max. (CMOS level)	

- 1,048,576 words x 16 bit organization
- Silicon gate, CMOS, Advanced Capacitor Cell
- All input and output are TTL compatible
- 4096 refresh cycles every 65.6ms
- Self refresh function
- Early write or OE controlled write capability
- RAS only, CAS-before-RAS, or Hidden Refresh
- Fast page Mode, Read-Modify-Write capability
- On chip substrate bias generator for high performance

ABSOLUTE MAXIMUM RATINGS (see NOTE)

Parameter	Symbol	Value	Unit
Voltage at any pin relative to V _{SS}	V _{IN} , V _{OUT}	-0.5 to + 7.0	V
Voltage of V _{CC} supply relative to V _{SS}	V _{CC}	-0.5 to + 7.0	V
Power Dissipation	PD	1.0	W
Short Circuit Output Current	—	50	mA
Operating Temperature	T _{OP}	0 to 70	°C
Storage Temperature	T _{STG}	-55 to +125	°C

NOTE: Permanent device damage may occur if the above **Absolute Maximum Ratings** are exceeded. Functional operation should be restricted to the conditions as detailed in the operational sections of this data sheet. Exposure to absolute maximum rating conditions for extended periods may affect device reliability.

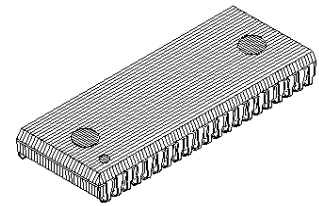

Plastic SOJ Package
(LCC-42P-M01)

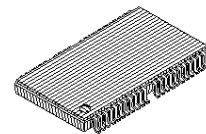

Plastic TSOP Packages
(FPT-50P-M06)
(Normal Bend)

Package and Ordering Information

- 42-pin plastic (400mil) SOJ, order as MB8116160A-xxPJ
- 50-pin plastic (400mil) TSOP-II with normal bend leads, order as MB8116160A-xxPFTN

This device contains circuitry to protect the inputs against damage due to high static voltages or electric fields. However, it is advised that normal precautions be taken to avoid application of any voltage higher than maximum rated voltages to this high impedance circuit.

- PRELIMINARY -

Edition 2.2

MB8116160A-60
MB8116160A-70

Fig. 1 - MB8116160A DYNAMIC RAM - BLOCK DIAGRAM

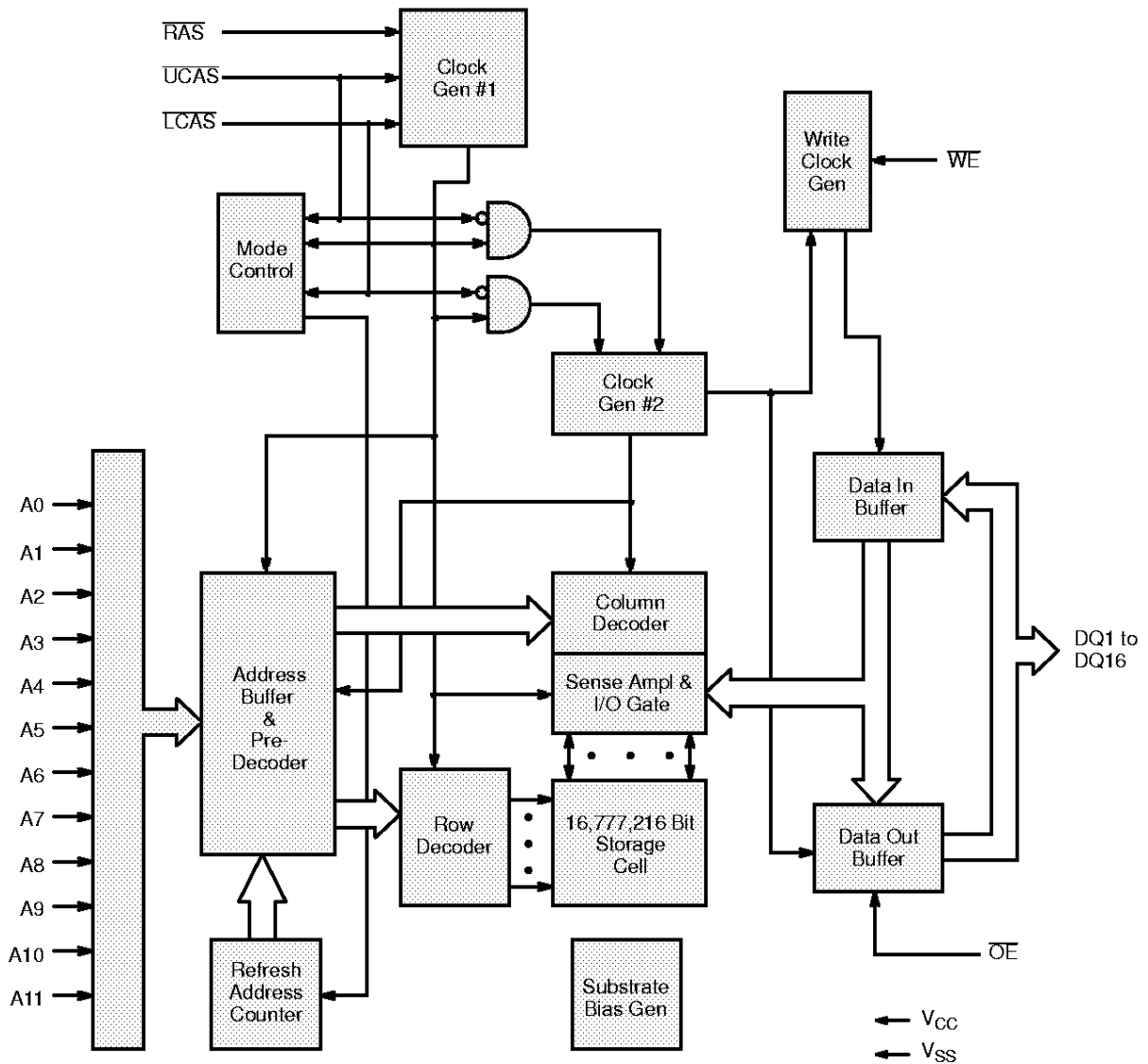

CAPACITANCE (T_A = 25°C, f = 1MHz)

Parameter	Symbol	Max	Unit
Input Capacitance, A0 to A11	C _{IN1}	5	pF
Input Capacitance, RAS, LCAS, UCAS, WE, OE	C _{IN2}	5	pF
Input/Output Capacitance, DQ1 to DQ16	C _{DQ}	7	pF

- PRELIMINARY -

Edition 2.2

MB8116160A-60
MB8116160A-70

PIN ASSIGNMENTS AND DESCRIPTIONS

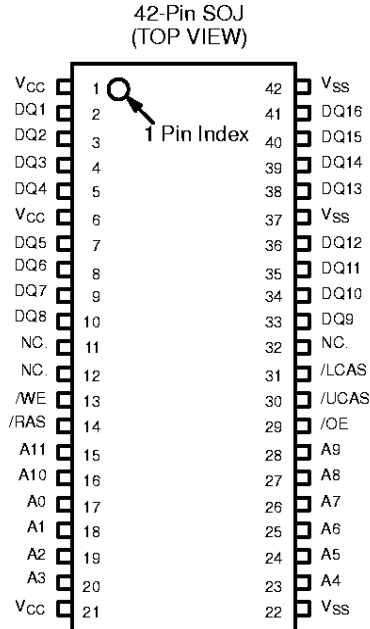

Designator	Function
A0 to A11	Address inputs row : A0 to A11 column : A0 to A7 refresh : A0 to A11
$\overline{\text{RAS}}$	Row address strobe
$\overline{\text{LCAS}}$	Lower column address strobe
$\overline{\text{UCAS}}$	Upper column address strobe
$\overline{\text{WE}}$	Write enable
$\overline{\text{OE}}$	Output enable
DQ1 to DQ16	Data Input/Output
V _{CC}	+5.0 volt power supply
V _{SS}	Circuit ground
NC.	No connection

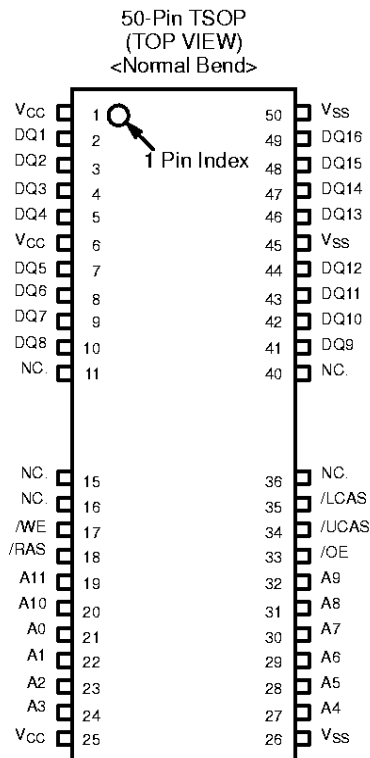

– PRELIMINARY –

Edition 2.2

MB8116160A-60
MB8116160A-70

RECOMMENDED OPERATING CONDITIONS

Parameter	Notes	Symbol	Min	Typ	Max	Unit	Ambient Operating Temp.
Supply Voltage	1	V_{CC}	4.5	5.0	5.5	V	0°C to +70°C
		V_{SS}	0	0	0		
Input High Voltage, all inputs	1	V_{IH}	2.4	—	6.5	V	
Input High Voltage, all inputs/outputs*	1	V_{IL}	–0.3	—	0.8	V	

* : Undershoots of up to –2.0 volts with a pulse width not exceeding 20ns are acceptable.

FUNCTIONAL OPERATION

ADDRESS INPUTS

Twenty input bits are required to decode any sixteen of 16,777,216 cell addresses in the memory matrix. Since only twelve address bits (A0 to A11) are available, the column and row inputs are separately strobed by \overline{LCAS} or \overline{UCAS} and \overline{RAS} as shown in Figure 1. First, twelve row address bits are input on pins A0–through–A11 and latched with the row address strobe (\overline{RAS}) then, eight column address bits are input and latched with the column address strobe (\overline{LCAS} or \overline{UCAS}). Both row and column addresses must be stable on or before the falling edges of \overline{RAS} and \overline{LCAS} or \overline{UCAS} , respectively. The address latches are of the flow-through type; thus, address information appearing after t_{RAH} (min) + t_T is automatically treated as the column address.

WRITE ENABLE

The read or write mode is determined by the logic state of \overline{WE} . When \overline{WE} is active Low, a write cycle is initiated; when \overline{WE} is High, a read cycle is selected. During the read mode, input data is ignored.

DATA INPUT

Input data is written into memory in either of three basic ways—an early write cycle, an \overline{OE} (delayed) write cycle, and a read-modify-write cycle. The falling edge of \overline{WE} or \overline{LCAS} / \overline{UCAS} , whichever is later, serves as the input data-latch strobe. In an early write cycle, the input data of DQ1–DQ8 is strobed by \overline{LCAS} and DQ9–DQ16 is strobed by \overline{UCAS} and the setup/hold times are referenced to each \overline{LCAS} and \overline{UCAS} because \overline{WE} goes Low before \overline{LCAS} / \overline{UCAS} . In a delayed write or a read-modify-write cycle, \overline{WE} goes Low after \overline{LCAS} / \overline{UCAS} ; thus, input data is strobed by \overline{WE} and all setup/hold times are referenced to the write-enable signal.

DATA OUTPUT

The three-state buffers are TTL compatible with a fanout of two TTL loads. Polarity of the output data is identical to that of the input; the output buffers remain in the high-impedance state until the column address strobe goes Low. When a read or read-modify-write cycle is executed, valid outputs are obtained under the following conditions:

- t_{RAC} : from the falling edge of \overline{RAS} when t_{RCD} (max) is satisfied.
- t_{CAC} : from the falling edge of \overline{LCAS} (for DQ1–DQ8) \overline{UCAS} (for DQ9–DQ16) when t_{RCD} is greater than t_{RCD} (max).
- t_{AA} : from column address input when t_{RAD} is greater than t_{RAD} (max).
- t_{OEA} : from the falling edge of \overline{OE} when \overline{OE} is brought Low after t_{RAC} , t_{CAC} , or t_{AA} , and t_{RCD} (mix.) is satisfied.

The data remains valid until either \overline{LCAS} / \overline{UCAS} or \overline{OE} returns to a High logic level. When an early write is executed, the output buffers remain in a high-impedance state during the entire cycle.

FAST PAGE MODE OF OPERATION

The fast page mode of operation provides faster memory access and lower power dissipation. The fast page mode is implemented by keeping the same row address and strobing in successive column addresses. To satisfy these conditions, \overline{RAS} is held Low for all contiguous memory cycles in which row addresses are common. For each fast page of memory, any of 256x16-bits can be accessed and, when multiple MB8116160As are used, \overline{CAS} is decoded to select the desired memory fast page. Fast page mode operations need not be addressed sequentially and combinations of read, write, and/or read-modify-write cycles are permitted.

- PRELIMINARY -

Edition 2.2

MB8116160A-60
MB8116160A-70

DC CHARACTERISTICS

(Recommended operating conditions unless otherwise noted)

Notes 3

Parameter	Notes	Symbol	Conditions	Value			Unit
				Min	Typ	Max	
Output high voltage	1	V_{OH}	$I_{OH} = -5.0\text{mA}$	2.4	—	—	V
Output low voltage	1	V_{OL}	$I_{OL} = +4.2\text{mA}$	—	—	0.4	
Input leakage current (any input)		$I_{I(L)}$	$0\text{V} \leq V_{IN} \leq V_{CC}$; $4.5\text{V} \leq V_{CC} \leq 5.5\text{V}$; $V_{SS} = 0\text{V}$; All other pins not under test = 0V	-10	—	10	μA
Output leakage current		$I_{DO(L)}$	$0\text{V} \leq V_{OUT} \leq V_{CC}$; Data out disabled	-10	—	10	
Operating current (Average power supply current)	MB8116160A-60	I_{CC1}	$\overline{\text{RAS}}$ & $\overline{\text{CAS}}$, $\overline{\text{UCAS}}$ cycling; $t_{RC} = \text{min}$	—	—	100	mA
	MB8116160A-70					90	
Standby current (Power supply current)	TTL level	I_{CC2}	$\overline{\text{RAS}} = \overline{\text{CAS}}$, $\overline{\text{UCAS}} = V_{IH}$	—	—	2.0	mA
	CMOS level		$\overline{\text{RAS}} = \overline{\text{CAS}}$, $\overline{\text{UCAS}} \geq V_{CC} - 0.2\text{V}$			1.0	
Refresh current #1 (Average power supply current)	MB8116160A-60	I_{CC3}	$\overline{\text{CAS}}$, $\overline{\text{UCAS}} = V_{IH}$, $\overline{\text{RAS}}$ cycling; $t_{RC} = \text{min}$	—	—	100	mA
	MB8116160A-70					90	
Fast Page Mode Current	MB8116160A-60	I_{CC4}	$\overline{\text{RAS}} = V_{IL}$, $\overline{\text{CAS}}$, $\overline{\text{UCAS}}$ cycling; $t_{PC} = \text{min}$	—	—	90	mA
	MB8116160A-70					80	
Refresh current #2 (Average power supply current)	MB8116160A-60	I_{CC5}	$\overline{\text{RAS}}$ cycling; $\overline{\text{CAS}}$ -before- $\overline{\text{RAS}}$; $t_{RC} = \text{min}$	—	—	90	mA
	MB8116160A-70					80	
Refresh current #3 (Average power sup- ply current)	MB8116160A-60	I_{CC9}	$\overline{\text{RAS}} = V_{IL}$, $\overline{\text{CAS}} = V_{IL}$ Self refresh ; $t_{\text{RASS}} = \text{min}$.	—	—	1000	μA
	MB8116160A-70						

- PRELIMINARY -

Edition 2.2

MB8116160A-60

MB8116160A-70

AC CHARACTERISTICS

(At recommended operating conditions unless otherwise noted.) Notes 3,4,5

No.	Parameter	Notes	Symbol	MB8116160A-60		MB8116160A-70		Unit
				Min	Max	Min	Max	
1	Time Between Refresh		t_{REF}	—	65.6	—	65.6	ms
2	Random Read/Write Cycle Time		t_{RC}	110	—	130	—	ns
3	Read-Modify-Write Cycle Time		t_{RWC}	150	—	174	—	ns
4	Access Time from RAS	6,9	t_{RAC}	—	60	—	70	ns
5	Access Time from CAS	7,9	t_{CAC}	—	15	—	17	ns
6	Column Address Access Time	8,9	t_{AA}	—	30	—	35	ns
7	Output Hold Time		t_{OH}	3	—	3	—	ns
8	Output Buffer Turn On Delay Time		t_{ON}	0	—	0	—	ns
9	Output Buffer Turn Off Delay Time	10	t_{OFF}	—	15	—	17	ns
10	Transition Time		t_T	3	50	3	50	ns
11	RAS Precharge Time		t_{RP}	40	—	50	—	ns
12	RAS Pulse Width		t_{RAS}	60	100000	70	100000	ns
13	RAS Hold Time		t_{RSH}	15	—	17	—	ns
14	CAS to RAS Precharge Time		t_{CRP}	5	—	5	—	ns
15	RAS to CAS Delay Time	11,12	t_{RCD}	20	45	20	53	ns
16	CAS Pulse Width		t_{CAS}	15	—	17	—	ns
17	CAS Hold Time		t_{CSH}	60	—	70	—	ns
18	CAS Precharge Time (Normal)	19	t_{CPN}	10	—	10	—	ns
19	Row Address Set Up Time		t_{ASR}	0	—	0	—	ns
20	Row Address Hold Time		t_{RAH}	10	—	10	—	ns
21	Column Address Set Up Time		t_{ASC}	0	—	0	—	ns
22	Column Address Hold Time		t_{CAH}	15	—	15	—	ns
23	Column Address Hold Time from RAS		t_{AR}	35	—	35	—	ns
24	RAS to Column Address Delay Time	13	t_{RAD}	15	30	15	35	ns
25	Column Address to RAS Lead Time		t_{RAL}	30	—	35	—	ns
26	Column Address to CAS Lead Time		t_{CAL}	30	—	35	—	ns
27	Read Command Set Up Time		t_{RCS}	0	—	0	—	ns
28	Read Command Hold Time Referenced to RAS	14	t_{RRH}	0	—	0	—	ns
29	Read Command Hold Time Referenced to CAS	14	t_{RCH}	0	—	0	—	ns
30	Write Command Set Up Time	15, 20	t_{WCS}	0	—	0	—	ns
31	Write Command Hold Time		t_{WCH}	15	—	15	—	ns
32	Write Hold Time from RAS		t_{WCR}	35	—	35	—	ns
33	WE Pulse Width		t_{WP}	15	—	15	—	ns
34	Write Command to RAS Lead Time		t_{RWL}	15	—	17	—	ns
35	Write Command to CAS Lead Time		t_{CWL}	15	—	17	—	ns

- PRELIMINARY -

Edition 2.2

MB8116160A-60
MB8116160A-70

AC CHARACTERISTICS (Continued)

(At recommended operating conditions unless otherwise noted.) Notes 3,4,5

No.	Parameter	Notes	Symbol	MB8116160A-60		MB8116160A-70		Unit
				Min	Max	Min	Max	
36	DIN Set Up Time		t_{DS}	0	—	0	—	ns
37	DIN Hold Time		t_{DH}	15	—	15	—	ns
38	Data Hold Time from RAS		t_{DHR}	35	—	35	—	ns
39	RAS to WE Delay Time	20	t_{RWD}	80	—	92	—	ns
40	CAS to WE Delay Time	20	t_{CWD}	35	—	39	—	ns
41	Column Address to WE Delay Time	20	t_{AWD}	50	—	57	—	ns
42	RAS Precharge Time to CAS Active Time (Refresh cycles)		t_{RPC}	5	—	5	—	ns
43	CAS Set Up Time for CAS-before-RAS Refresh		t_{CSR}	0	—	0	—	ns
44	CAS Hold Time for CAS-before-RAS Refresh		t_{CHR}	10	—	12	—	ns
45	Access Time from OE	9	t_{OEA}	—	15	—	17	ns
46	Output Buffer Turn Off Delay from OE	10	t_{OEZ}	—	15	—	17	ns
47	OE to RAS Lead Time for Valid Data		t_{OEL}	10	—	10	—	ns
48	OE Hold Time Referenced to WE	16	t_{OEH}	5	—	5	—	ns
49	OE to Data In Delay Time		t_{OED}	15	—	17	—	ns
50	CAS to Data In Delay Time		t_{CDD}	15	—	17	—	ns
51	DIN to CAS Delay Time	17	t_{DZC}	0	—	0	—	ns
52	DIN to OE Delay Time	17	t_{DZO}	0	—	0	—	ns
60	Fast Page Mode RAS Pulse width		t_{RASP}	—	100000	—	100000	ns
61	Fast Page Mode Read/Write Cycle Time		t_{PC}	40	—	45	—	ns
62	Fast Page Mode Read-Modify-Write Cycle Time		t_{PRWC}	80	—	89	—	ns
63	Access Time from CAS Precharge	9,18	t_{CPA}	—	35	—	40	ns
64	Fast Page Mode CAS Precharge Time		t_{CP}	10	—	10	—	ns
65	Fast Page Mode RAS Hold Time from CAS Precharge		t_{RHCP}	35	—	40	—	ns
66	Fast Page Mode CAS Precharge to WE Delay Time		t_{CPWD}	55	—	62	—	ns

– PRELIMINARY –

Edition 2.2

MB 8116160A-60

MB 8116160A-70

Notes:

1. Referenced to V_{SS} .
2. I_{CC} depends on the output load conditions and cycle rates; The specified values are obtained with the output open.
 I_{CC} depends on the number of address change as $\overline{RAS} = V_{IL}$, $\overline{UCAS} = V_{IH}$, $\overline{LCAS} = V_{IH}$ and $V_{IL} > -0.3V$.
 I_{CC1} , I_{CC3} , I_{CC4} and I_{CC5} are specified at one time of address change during $\overline{RAS} = V_{IL}$ and $\overline{UCAS} = V_{IH}$, $\overline{LCAS} = V_{IH}$.
 I_{CC2} is specified during $\overline{RAS} = V_{IH}$ and $V_{IL} > -0.3V$.
3. An initial pause ($\overline{RAS} = \overline{CAS} = V_{IH}$) of 200 μ s is required after power-up followed by any eight \overline{RAS} -only cycles before proper device operation is achieved. In case of using internal refresh counter, a minimum of eight \overline{CAS} -before- \overline{RAS} initialization cycles instead of 8 \overline{RAS} cycles are required.
4. AC characteristics assume $t_T = 5ns$.
5. V_{IH} (min) and V_{IL} (max) are reference levels for measuring timing of input signals. Also transition times are measured between V_{IH} (min) and V_{IL} (max).
6. Assumes that $t_{RCD} \leq t_{RCD} (max)$, $t_{RAD} \leq t_{RAD} (max)$. If t_{RCD} is greater than the maximum recommended value shown in this table, t_{RAC} will be increased by the amount that t_{RCD} exceeds the value shown. Refer to Fig.2 and 3.
7. If $t_{RCD} \geq t_{RCD} (max)$, $t_{RAD} \geq t_{RAD} (max)$, and $t_{ASC} \geq t_{AA} - t_{CAC} - t_T$, access time is t_{CAC} .
8. If $t_{RAD} \geq t_{RAD} (max)$ and $t_{ASC} \leq t_{AA} - t_{CAC} - t_T$, access time is t_{AA} .
9. Measured with a load equivalent to two TTL loads and 50pF.
10. t_{OFF} and t_{OEZ} are specified that output buffer change to high impedance state.
11. Operation within the $t_{RCD} (max)$ limit ensures that $t_{RAC} (max)$ can be met. $t_{RCD} (max)$ is specified as a reference point only; if t_{RCD} is greater than the specified $t_{RCD} (max)$ limit, access time is controlled exclusively by t_{CAC} or t_{AA} .
12. $t_{RCD} (min) = t_{RAH} (min) + 2t_T + t_{ASC} (min)$.
13. Operation within the $t_{RAD} (max)$ limit ensures that $t_{RAC} (max)$ can be met. $t_{RAD} (max)$ is specified as a reference point only; if t_{RAD} is greater than the specified $t_{RAD} (max)$ limit, access time is controlled exclusively by t_{CAC} or t_{AA} .
14. Either t_{RRH} or t_{RCH} must be satisfied for a read cycle.
15. t_{WCS} is specified as a reference point only. If $t_{WCS} \geq t_{WCS} (min)$ the data output pin will remain High-Z state through entire cycle.
16. Assumes that $t_{WCS} < t_{WCS} (min)$.
17. Either t_{DZC} or t_{DZO} must be satisfied.
18. t_{CPA} is access time from the selection of a new column address (that is caused by changing both \overline{UCAS} and \overline{LCAS} from "L" to "H"). Therefore, if t_{CP} is long, t_{CPA} is longer than $t_{CPA} (max)$.
19. Assumes that \overline{CAS} -before- \overline{RAS} refresh.
20. t_{WCS} , t_{CWD} , t_{RWD} , t_{AWD} and t_{CPWD} are not restrictive operating parameters. They are included in the data sheet as an electrical characteristic only. If $t_{WCS} \geq t_{WCS} (min)$, the cycle is an early write cycle and D_{OUT} pin will maintain high impedance state through-out the entire cycle. If $t_{CWD} \geq t_{CWD} (min)$, $t_{RWD} \geq t_{RWD} (min)$, $t_{AWD} \geq t_{AWD} (min)$ and $t_{CPWD} \geq t_{CPWD} (min)$, the cycle is a read-modify-write cycle and data from the selected cell will appear at the D_{OUT} pin. If neither of the above conditions is satisfied, the cycle is a delayed write cycle and invalid data will appear the D_{OUT} pin, and write operation can be executed by satisfying t_{RWL} , t_{CWL} , and t_{RAL} specifications.

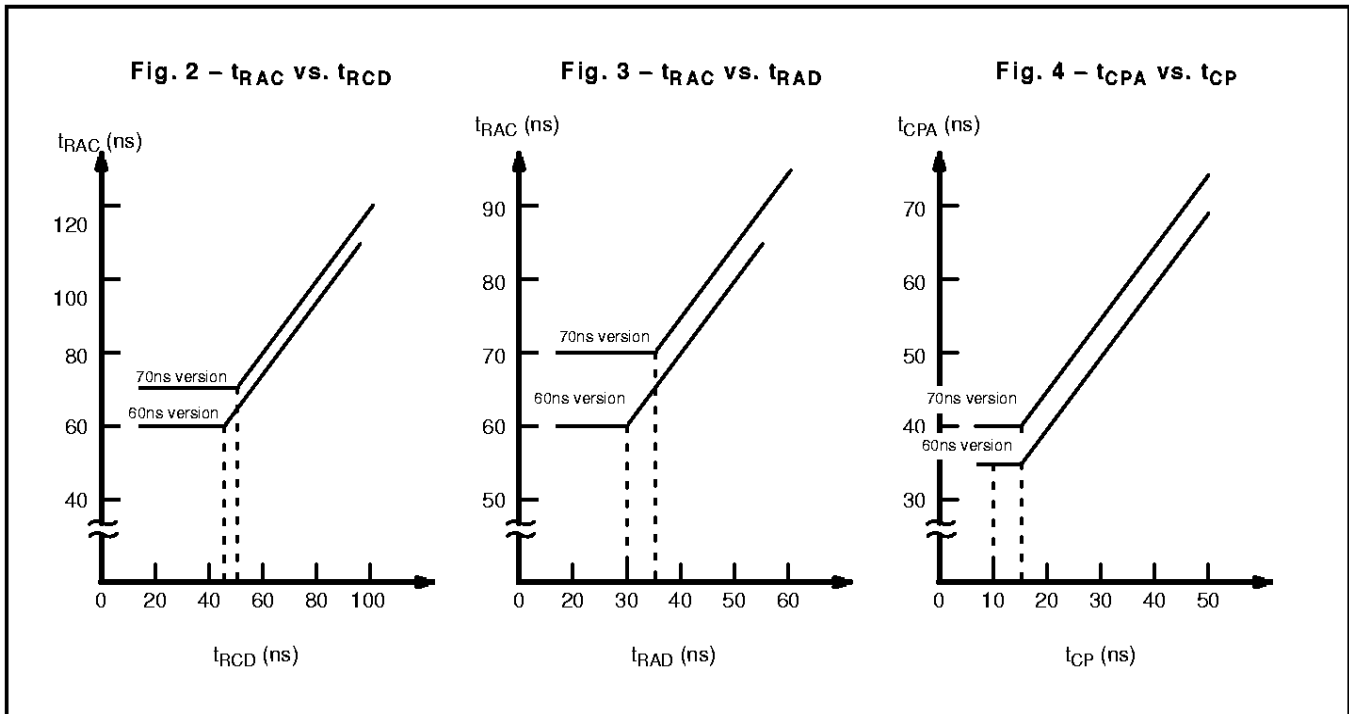

FUNCTIONAL TRUTH TABLE

Operation Mode	Clock Input					Address		Input/Output Data				Refresh	Note	
	\overline{RAS}	\overline{LCAS}	\overline{UCAS}	\overline{WE}	\overline{OE}	Row	Column	DQ1 to DQ8		DQ9 to DQ16				
								Input	Output	Input	Output			
Standby	H	H	H	X	X	-	-	-	High-Z	-	High-Z	-		
Read Cycle	L	L H L	H L L	H	L	Valid	Valid	-	Valid High-Z Valid	-	High-Z Valid Valid	Yes*	$t_{RCS} \geq t_{RCS}(\text{min})$	
Write Cycle (Early Write)	L	L H L	H L L	L	X	Valid	Valid	Valid - Valid	High-Z	-	Valid Valid	High-Z	Yes*	$t_{WCS} \geq t_{WCS}(\text{min})$
Read-Modify- Write Cycle	L	L H L	H L L	H→L	L→H	Valid	Valid	Valid - Valid	Valid High-Z Valid	-	High-Z Valid Valid	Yes*		
\overline{RAS} -only Refresh Cycle	L	H	H	X	X	Valid	-	-	High-Z	-	High-Z	Yes		
\overline{CAS} -before- \overline{RAS} Refresh Cycle	L	L	L	X	X	-	-	-	High-Z	-	High-Z	Yes	$t_{CSR} \geq t_{CSR}(\text{min})$	
Hidden Refresh Cycle	H→L	L H L	H L L	H→X	L	-	-	-	Valid High-Z Valid	-	High-Z Valid Valid	Yes	Previous data is kept	

X; "H" or "L"

*; It is impossible in Fast Page Mode.

Fig. 6 - EARLY WRITE CYCLE (\overline{OE} = "H" or "L")

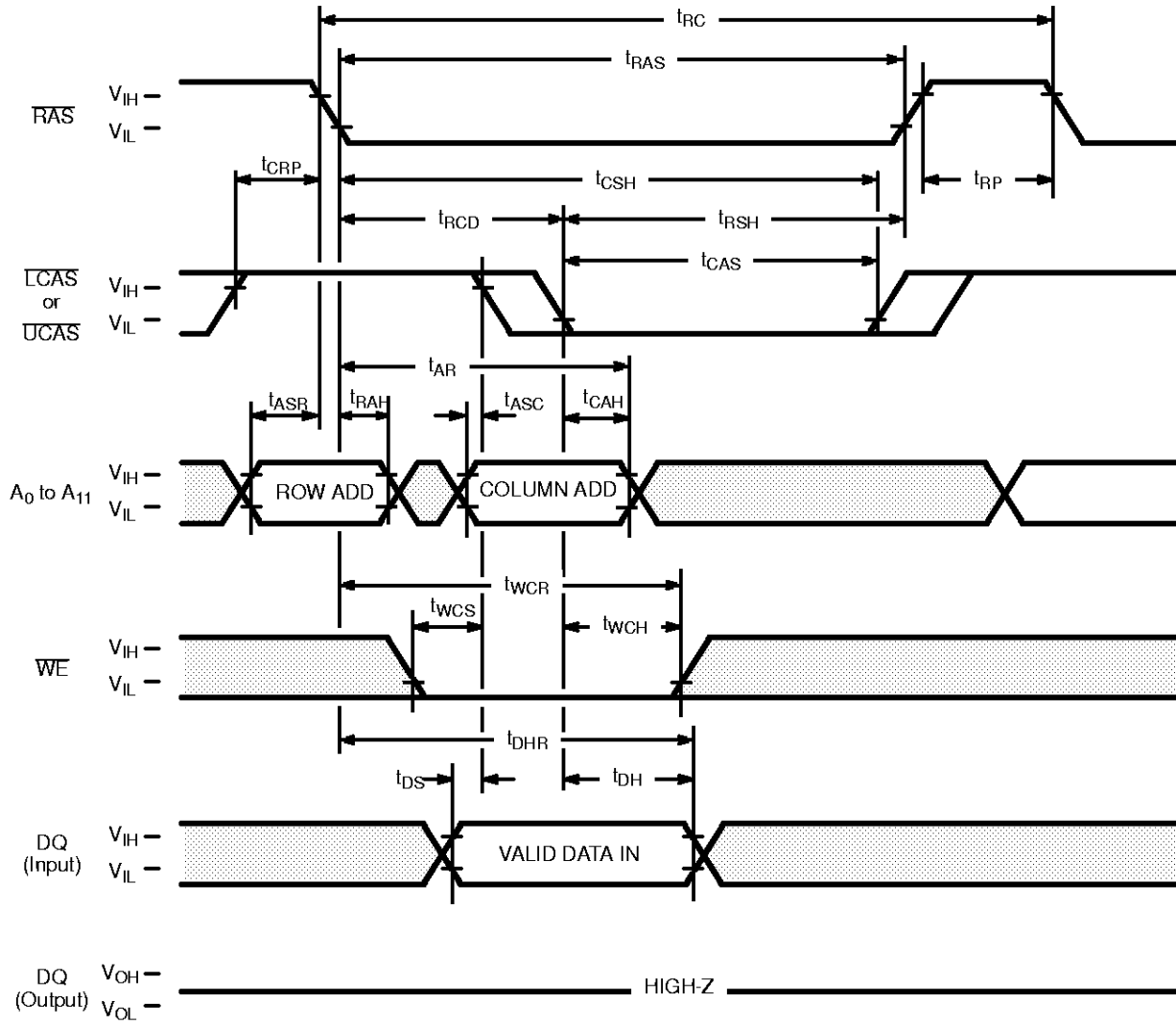

 "H" or "L"

DESCRIPTION

A write cycle is similar to a read cycle except \overline{WE} is set to a Low state and \overline{OE} is an "H" or "L" signal. A write cycle can be implemented in either of three ways – early write, delayed write, or read-modify-write. During all write cycles, timing parameters t_{RWL} , t_{CWL} , t_{RAL} and t_{CAL} must be satisfied. In the early write cycle shown above t_{WCS} satisfied, data on the DQ pins are latched with the falling edge of \overline{LCAS} or \overline{UCAS} and written into memory.

- PRELIMINARY -

Edition 2.2

MB8116160A-60
MB8116160A-70

Fig. 7 - DELAYED WRITE CYCLE

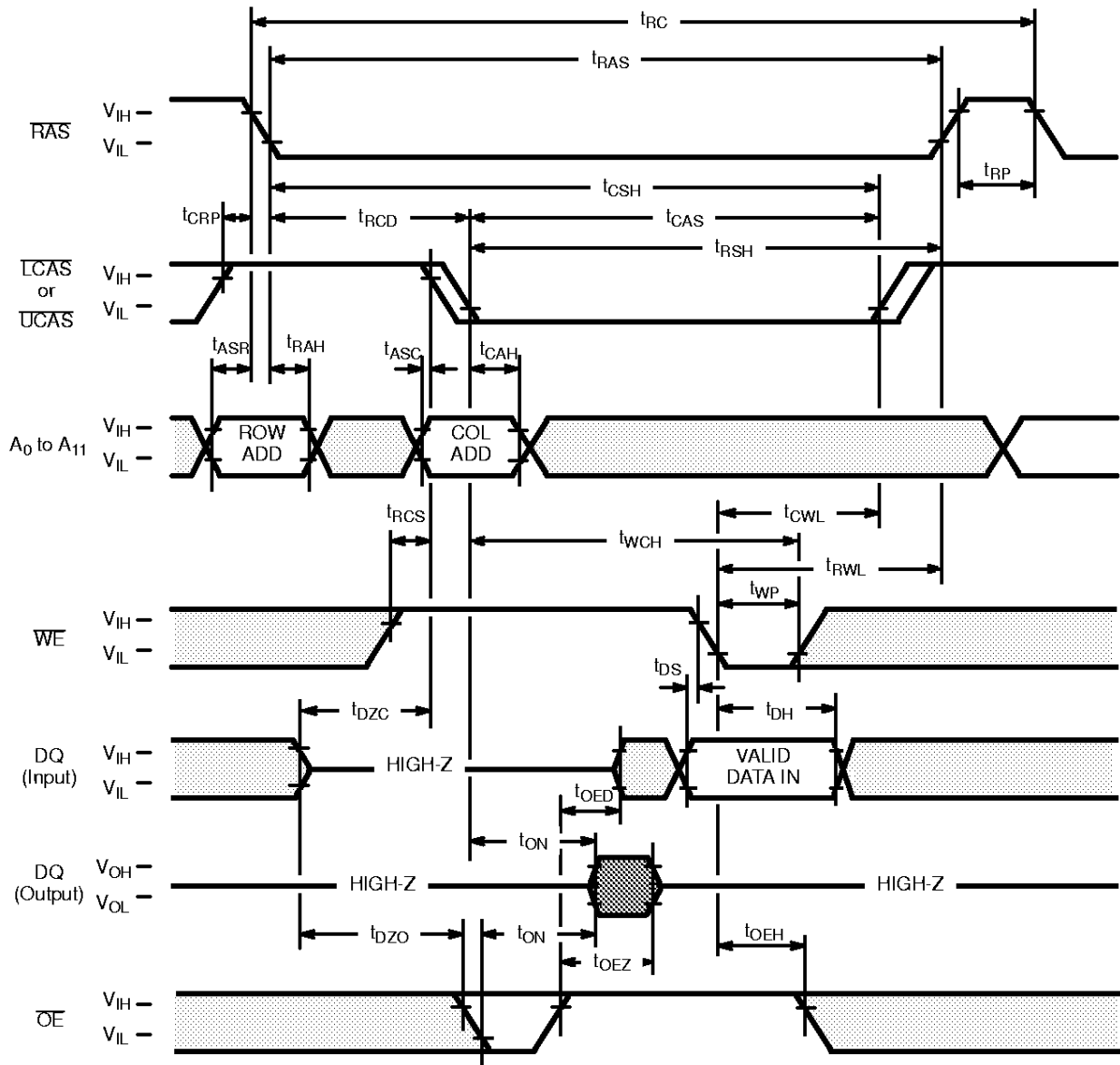

DESCRIPTION

In the delayed write cycle, t_{WCS} is not satisfied; thus, the data on the DQ pins is latched with the falling edge of \overline{WE} and written into memory. The Output Enable (\overline{OE}) signal must be changed from Low to High before \overline{WE} goes Low ($t_{OED} + t_r + t_{DS}$).

- PRELIMINARY -

Edition 2.2

MB8116160A-60
MB8116160A-70

Fig. 9 - FAST PAGE MODE READ CYCLE

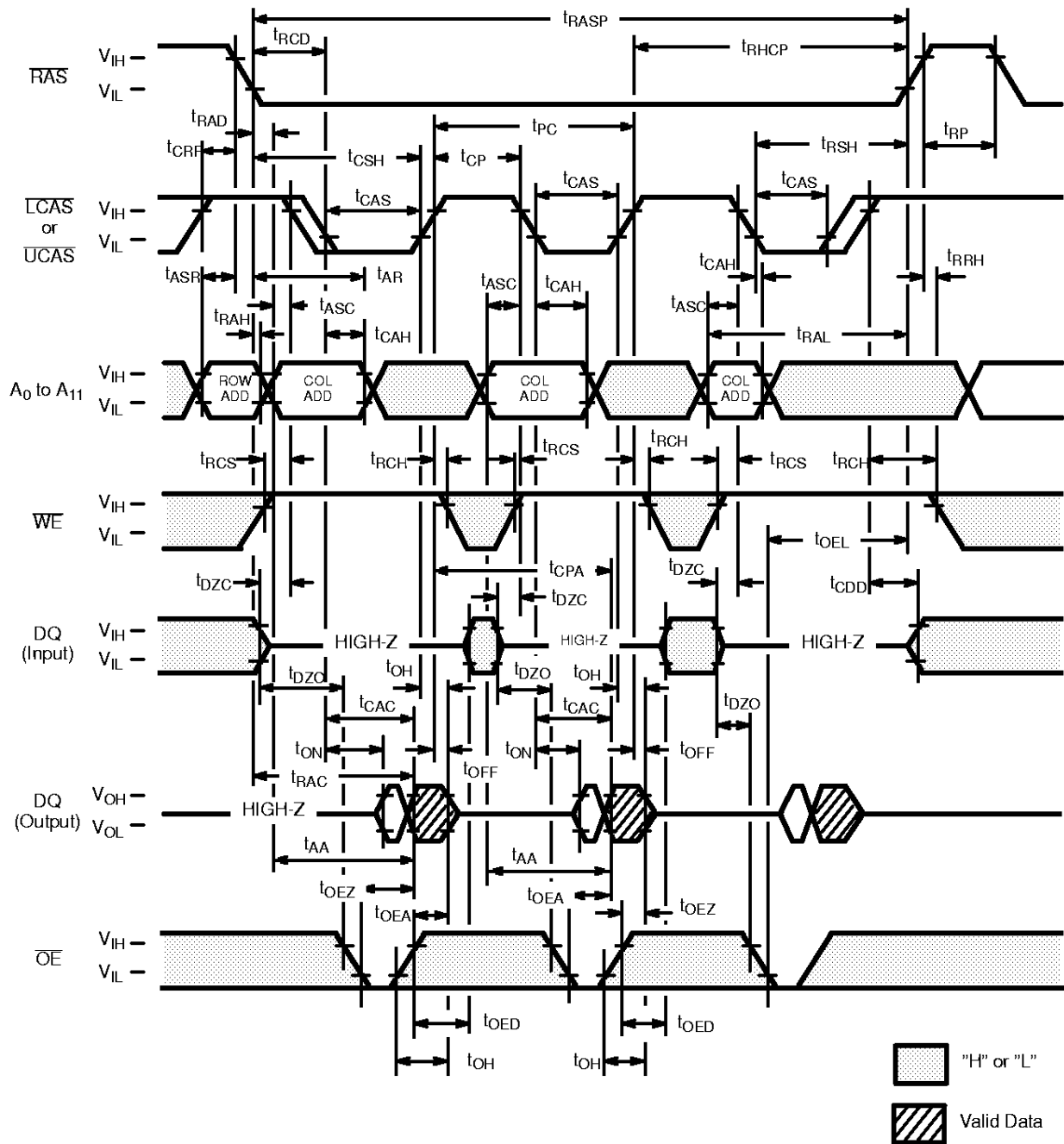

DESCRIPTION

The fast page mode of operation permits faster successive memory operations at multiple column locations of the same row address. This operation is performed by strobing in the row address and maintaining RAS at a Low level and WE at a High level during all successive memory cycles in which the row address is latched. The access time is determined by t_{CAC} , t_{AA} , t_{CPA} , or t_{OEA} , whichever one is the lastest in occurring.

Fig. 10 - FAST PAGE MODE EARLY WRITE CYCLE ($\overline{OE} = "H" \text{ or } "L"$)

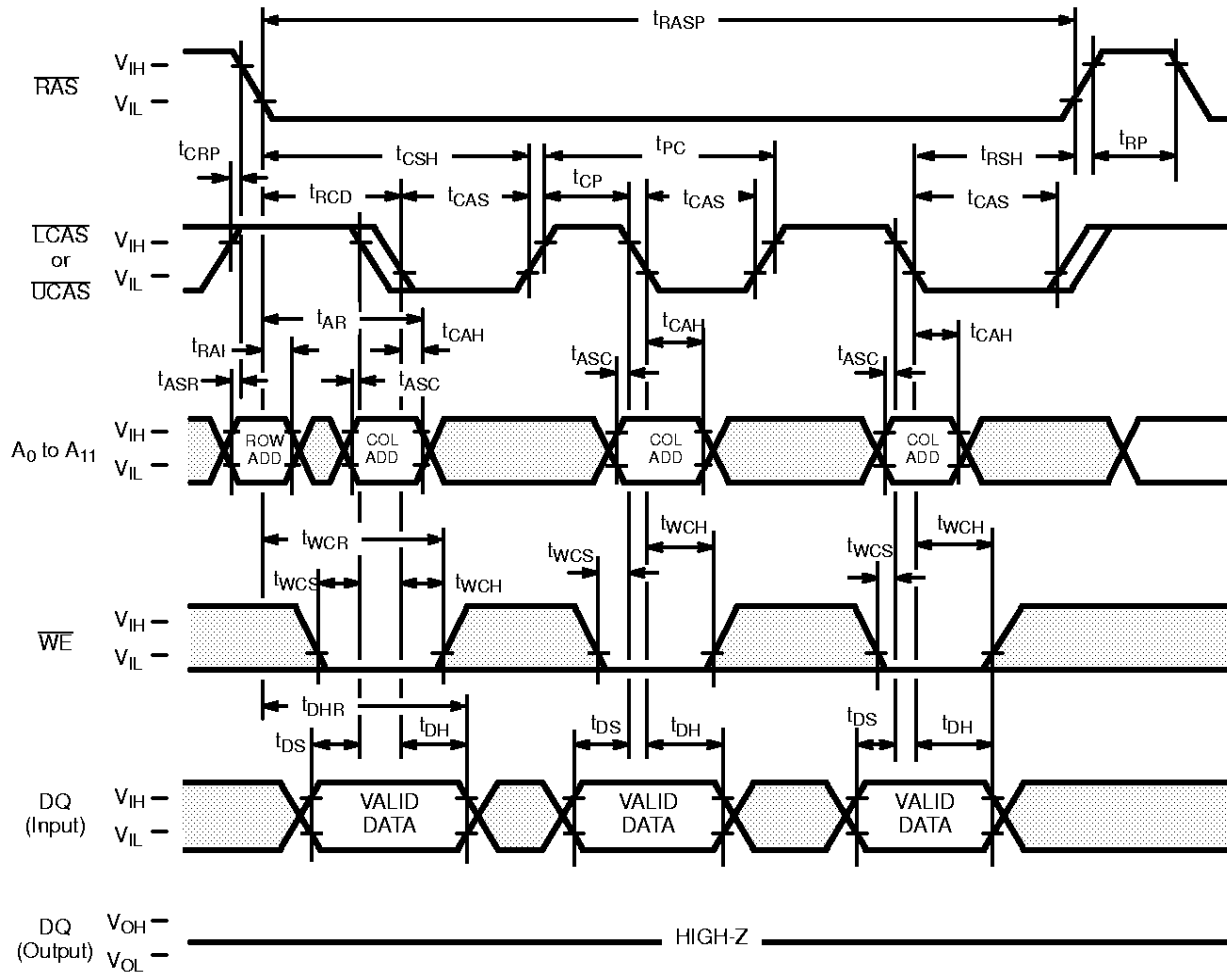

DESCRIPTION

The fast page mode early write cycle is executed in the same manner as the fast page mode read cycle except the states of \overline{WE} and \overline{OE} are reversed. Data appearing on the DQ1 to DQ8 is latched on the falling edge of \overline{LCAS} and one appearing on the DQ9 to DQ16 is latched on the falling edge of \overline{UCAS} and the data is written into the memory. During the fast page mode early write cycle, including the delayed (\overline{OE}) write and read-modify-write cycles, t_{CWL} must be satisfied.

- PRELIMINARY -

Edition 2.2

MB8116160A-60
MB8116160A-70

Fig. 11 - FAST PAGE MODE DELAYED WRITE CYCLE

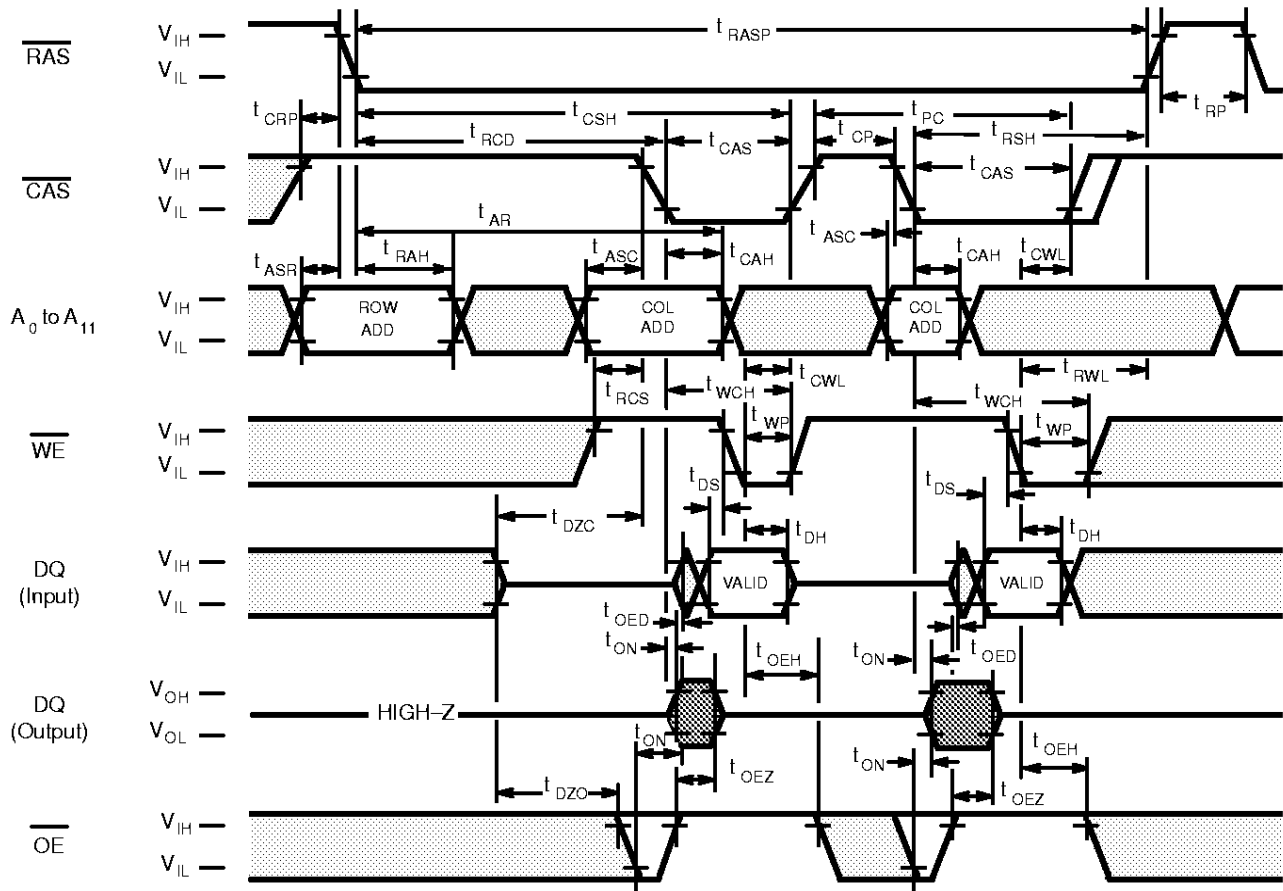

"H" or "L"
 Invalid Data

DESCRIPTION

The fast page mode delayed write cycle is executed in the same manner as the fast page mode early write cycle except for the states of \overline{WE} and \overline{OE} . Input data on the DQ pins are latched on the falling edge of \overline{WE} and written into memory. In the fast page mode delayed write cycle, \overline{OE} must be changed from Low to High before \overline{WE} goes Low ($t_{OED} + t_T + t_{DS}$).

- PRELIMINARY -

Edition 2.2

MB8116160A-60
MB8116160A-70

Fig. 13 - $\overline{\text{RAS}}$ -ONLY REFRESH ($\overline{\text{WE}} = \overline{\text{OE}} = \text{"H"}$ or "L")

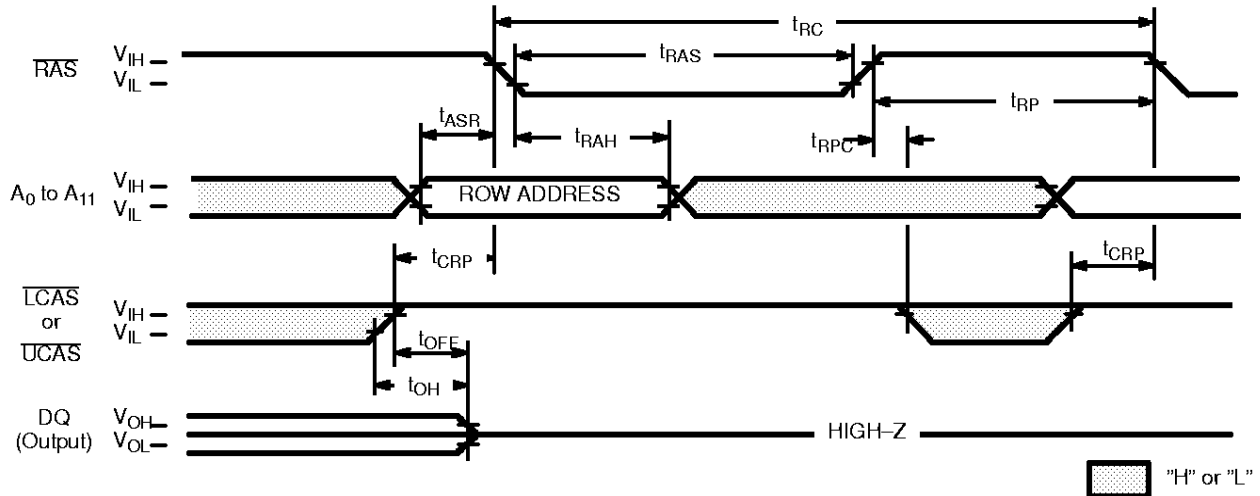

DESCRIPTION

Refresh of RAM memory cells is accomplished by performing a read, a write, or a read-modify-write cycle at each of 4096 row addresses every 65.6-milliseconds. Three refresh modes are available: $\overline{\text{RAS}}$ -only refresh, $\overline{\text{CAS}}$ -before- $\overline{\text{RAS}}$ refresh, and hidden refresh.

$\overline{\text{RAS}}$ -only refresh is performed by keeping $\overline{\text{RAS}}$ Low and $\overline{\text{LCAS}}$ and $\overline{\text{UCAS}}$ High throughout the cycle; the row address to be refreshed is latched on the falling edge of $\overline{\text{RAS}}$. During $\overline{\text{RAS}}$ -only refresh, DQ pins are kept in a high-impedance state.

Fig. 14 - $\overline{\text{CAS}}$ -BEFORE- $\overline{\text{RAS}}$ REFRESH (ADDRESSES = $\overline{\text{WE}} = \overline{\text{OE}} = \text{"H"}$ or "L")

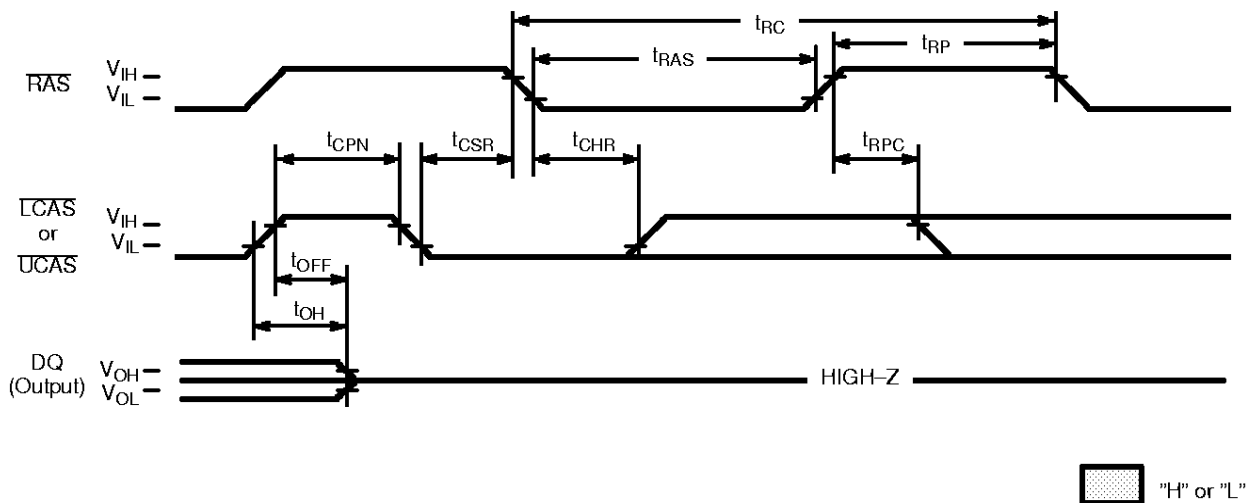

DESCRIPTION

$\overline{\text{CAS}}$ -before- $\overline{\text{RAS}}$ refresh is an on-chip refresh capability that eliminates the need for external refresh addresses. If $\overline{\text{LCAS}}$ or $\overline{\text{UCAS}}$ is held Low for the specified setup time (t_{CSR}) before $\overline{\text{RAS}}$ goes Low, the on-chip refresh control clock generators and refresh address counter are enabled. An internal refresh operation automatically occurs and the refresh address counter is internally incremented in preparation for the next $\overline{\text{CAS}}$ -before- $\overline{\text{RAS}}$ refresh operation.

Fig. 15 - HIDDEN REFRESH CYCLE

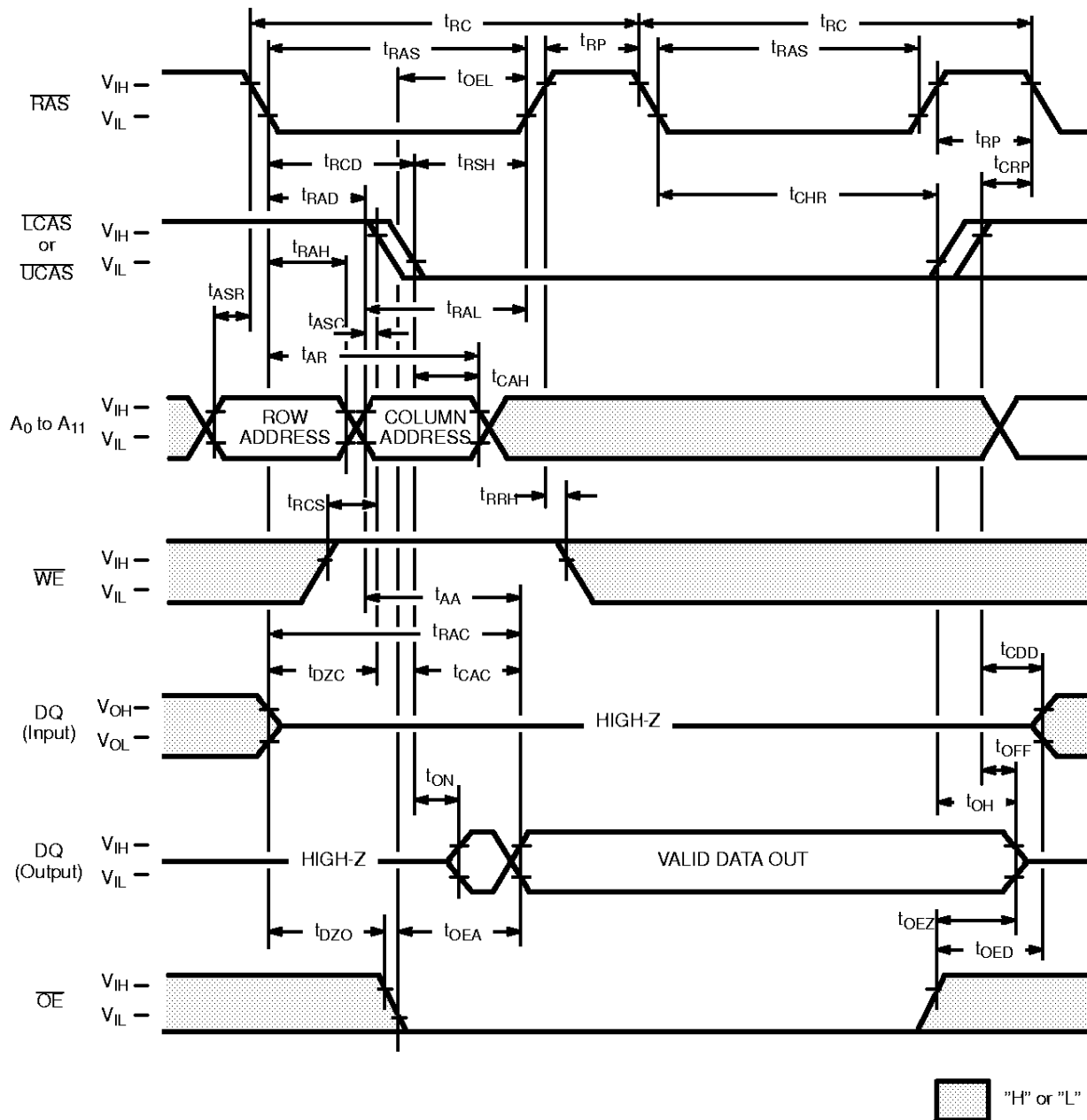

DESCRIPTION

A hidden refresh cycle may be performed while maintaining the latest valid data at the output by extending the active time of \overline{LCAS} or \overline{UCAS} and cycling \overline{RAS} . The refresh row address is provided by the on-chip refresh address counter. This eliminates the need for the external row address that is required by DRAMs that do not have \overline{CAS} -before- \overline{RAS} refresh capability.

Fig. 17 - SELF REFRESH CYCLE (A0-A11 = \overline{WE} = \overline{OE} = "H" or "L")

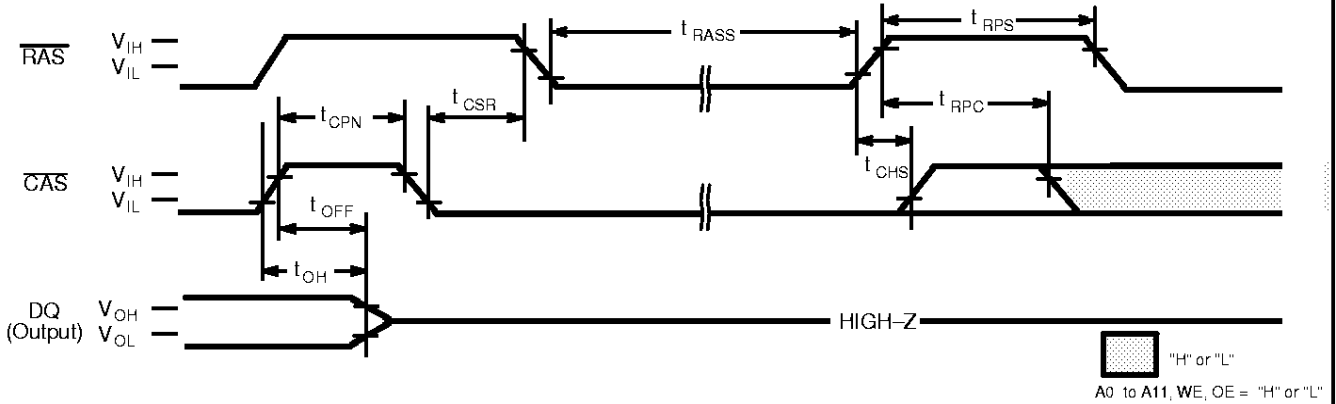

(At recommended operating conditions unless otherwise noted.)

No.	Parameter	Symbol	MB8116160A-60		MB8116160A-70		Unit
			Min	Max	Min	Max	
100	\overline{RAS} Pulse Width	t_{RASS}	100	—	100	—	μs
101	\overline{RAS} Precharge Time	t_{RPS}	110	—	125	—	ns
102	\overline{CAS} Hold Time	t_{CHS}	-50	—	-50	—	ns

Note . Assumes self refresh cycle only.

DESCRIPTION

The self refresh cycle provides a refresh operation without external clock and external Address. Self refresh control circuit on chip is operated in the self refresh cycle and refresh operation can be automatically executed using internal refresh address counter and timing generator. If \overline{CAS} goes to "L" before \overline{RAS} goes to "L" (CBR) and the condition of \overline{CAS} "L" and \overline{RAS} "L" is kept for term of t_{RASS} (more than 100 μs), the device can enter the self refresh cycle. Following that, refresh operation is automatically executed at fixed intervals using internal refresh address counter during \overline{RAS} =L" and " \overline{CAS} =L".

Exit from self refresh cycle is performed by toggling \overline{RAS} and \overline{CAS} to "H" with specified t_{CHS} min.. In this time, \overline{RAS} must be kept "H" with specified t_{RPS} min..

Using self refresh mode, data can be retained without external \overline{CAS} signal during system is in standby.

Restriction for Self Refresh operation ;

For self refresh operation, the notice below must be considered.

- 1) In the case that distributed CBR refresh are operated between read/write cycles
Self refresh cycles can be executed without special rule if 4,096 cycles of distributed CBR refresh are executed within t_{REF} max..
- 2) In the case that burst CBR refresh or distributed/burst /RAS only refresh are operated between read/write cycles
4,096 times of burst CBR refresh or 4,096 times of burst /RAS only refresh must be executed before and after Self refresh cycles.

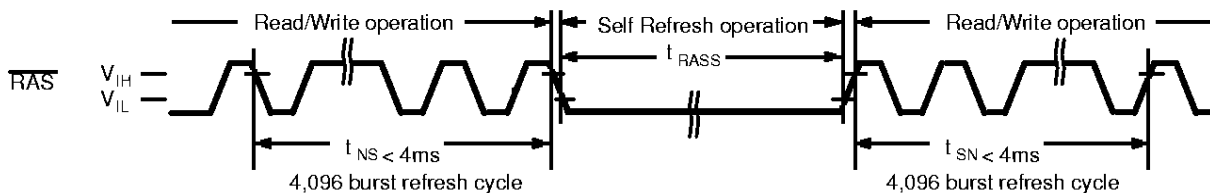

* Read/write operation can be performed non refresh time within t_{NS} or t_{SN} .

- PRELIMINARY -

Edition 2.2

MB8116160A-60
MB8116160A-70

PACKAGE DIMENSIONS

(Suffix: -PJ)

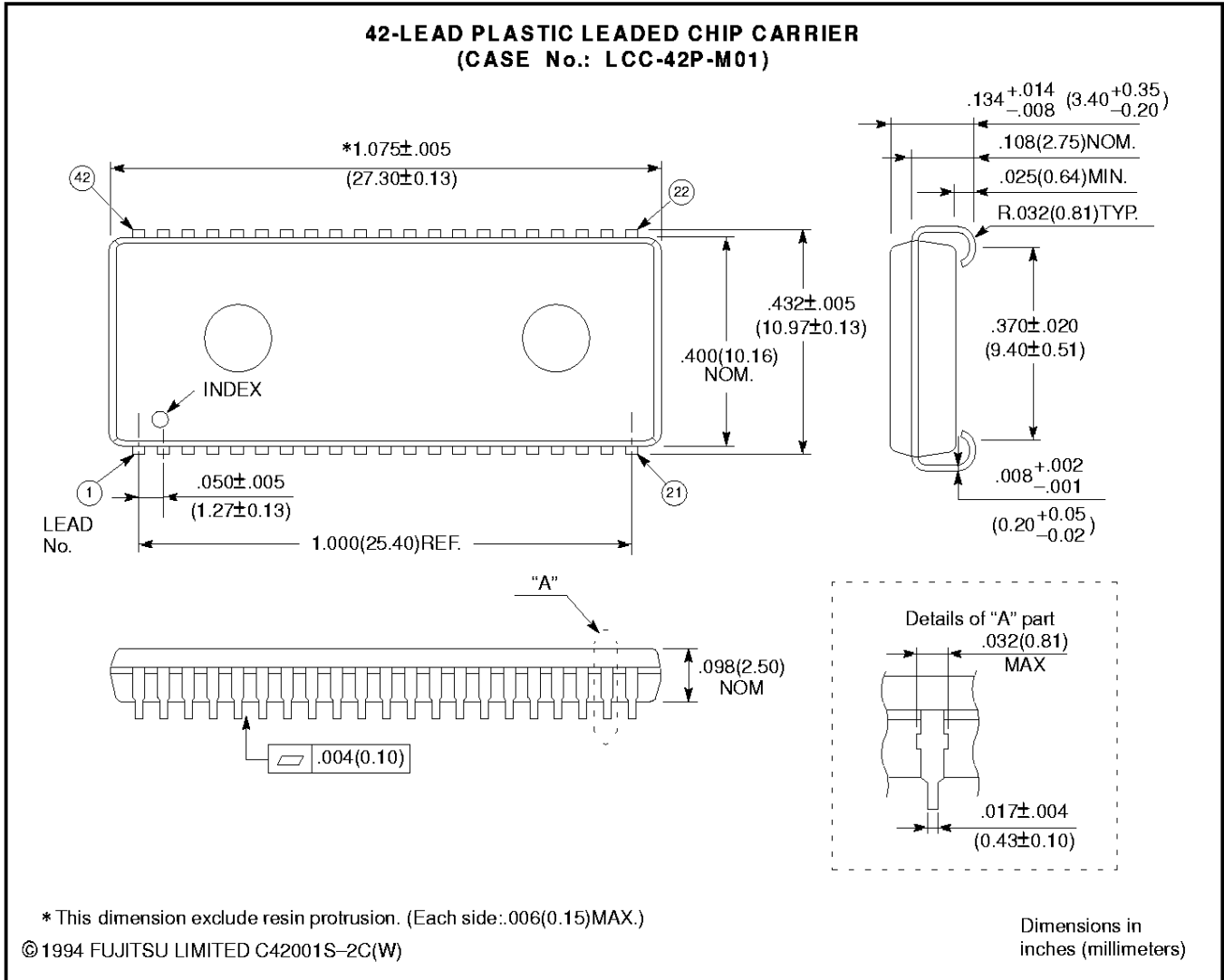

- PRELIMINARY -

Edition 2.2

MB 8116160A-60
MB 8116160A-70

PACKAGE DIMENSIONS (Continued) (Suffix: -PFTN)

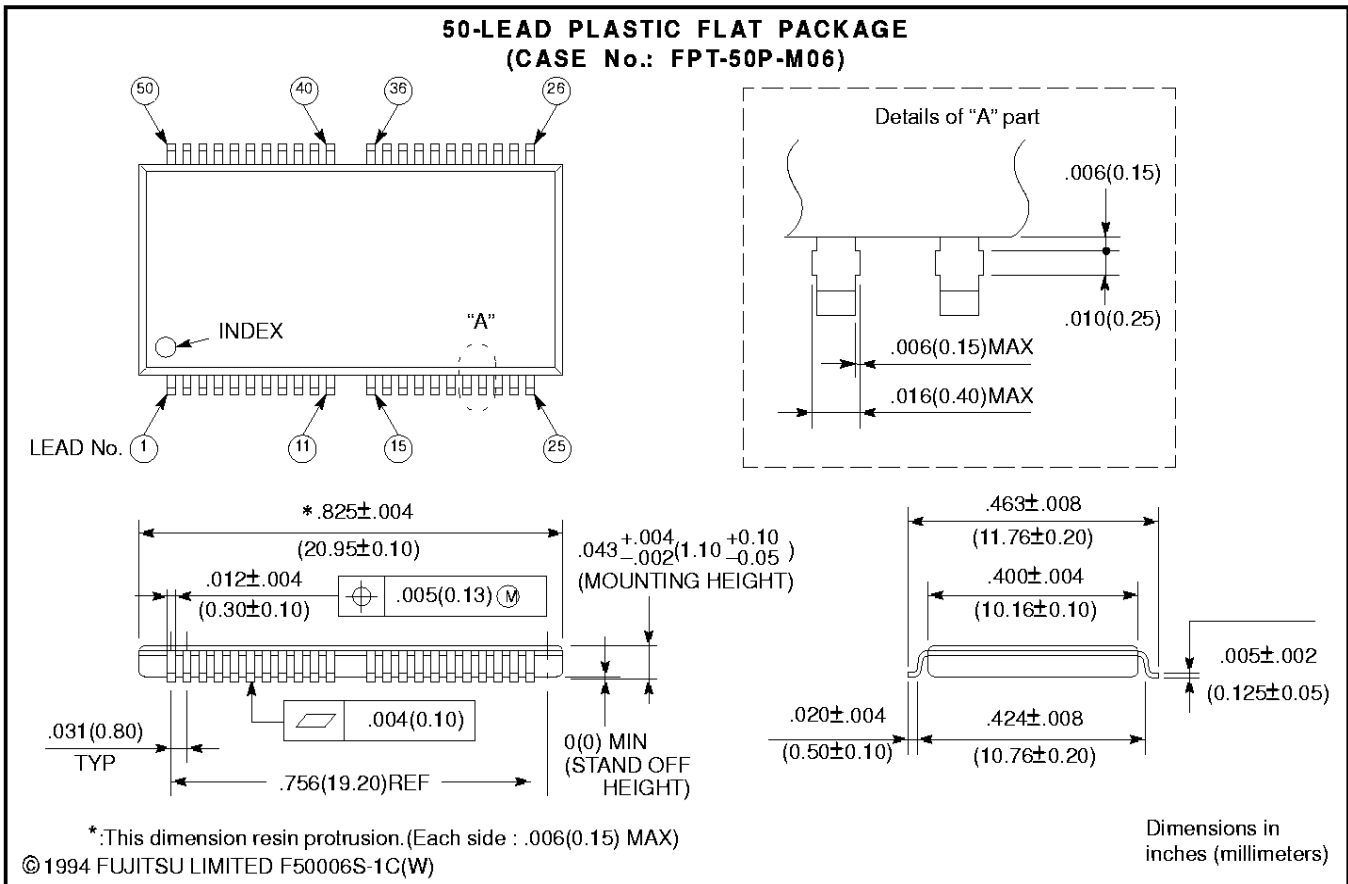

All Rights Reserved.

Circuit diagrams utilizing Fujitsu products are included as a means of illustrating typical semiconductor applications. Complete information sufficient for construction purposes is not necessarily given.

The information contained in this document has been carefully checked and is believed to be reliable. However, Fujitsu assumes no responsibility for inaccuracies.

The information contained in this document does not convey any license under the copyrights, patent rights or trademarks claimed and owned by Fujitsu.

Fujitsu reserves the right to change products or specifications without notice.

No part of this publication may be copied or reproduced in any form or by any means, or transferred to any third party without prior written consent of Fujitsu.

The products described in this document are not intended for use in equipment requiring high reliability, such as marine relays and medical life-support systems. For such applications, contact your Fujitsu sales representative.

If the products and technologies described in this document are controlled by the Foreign Exchange and Foreign Trade Control Act established in Japan, their export is subject to prior approval based on the said act.

– PRELIMINARY –

Edition 2.2

MB 8116160A-60

MB 8116160A-70

Visit our web site for the latest information:

<http://www.fujitsumicro.com>

Customer Response Center:

For semiconductor products, flat panel displays, and PC cards in the U.S., Canada and Mexico, please contact the Fujitsu Microelectronics Customer Response Center (CRC). The CRC provides a single point of contact for resolving customer issues and answering technical questions.

- Web:** Click on Tech Support in the FMI home page, then submit our form
- Tel:** Telephone: 1-800-866-8608 Monday through Friday, 7 to 5 PST
Outside U.S., Canada & Mexico call: 010-1-408-922-9000 and ask
for the Customer Response Center. *(Note: Country Code may vary)*
- Fax:** (408) 922-9179
- E-Mail:** fmirc@fmi.fujitsu.com

FJ ID NUMBER DS05-10165-2E

MP-DRAM-DS-20102-5/96