

**MARKETING SALES DRAWING**  
**DIMENSIONS IN INCHES - DO NOT SCALE THIS DRAWING**  
**DIMENSIONS IN METRIC - [ ]**

Electrical Testing  
per Tusonix standard  
test plans and Mil-Std-202  
Test Methods.

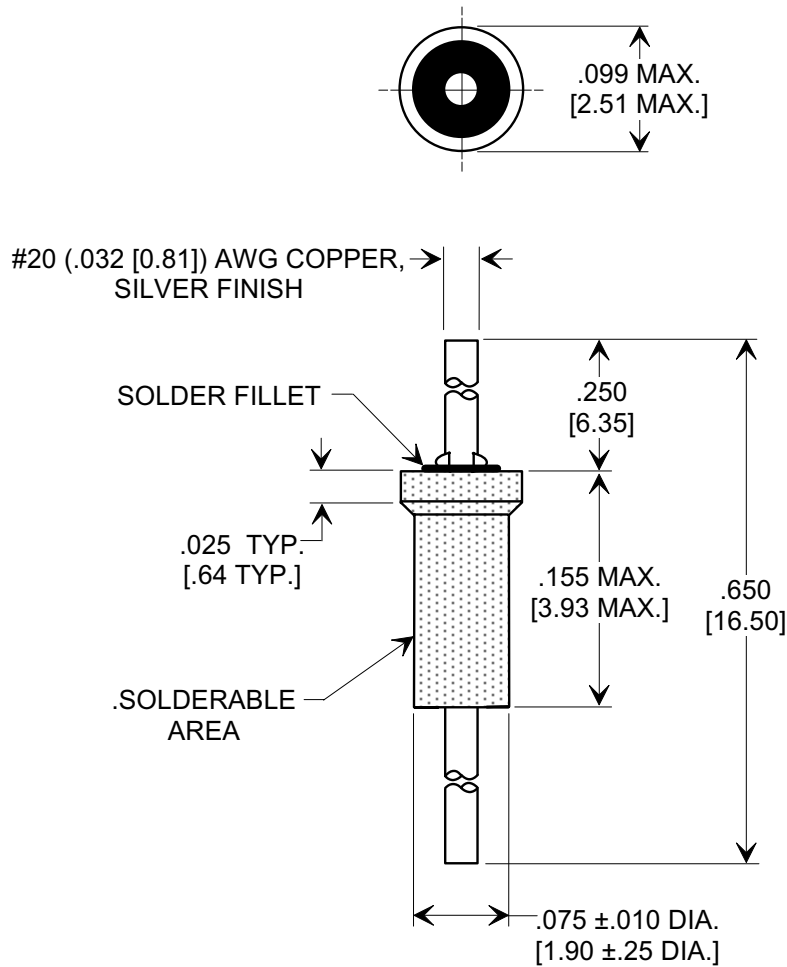
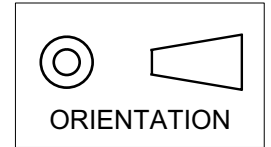

**NOTES:**

- TUSONIX STANDARD PART NUMBER: 2463-002-X5U0-152P.  
TUSONIX RoHS COMPLIANT PART  
NUMBER: 2463-002-X5U0-152P LF.  
CUSTOMER MUST SPECIFY STANDARD OR RoHS PART  
NUMBER WHEN ORDERING.
- PART MARKING: STANDARD PART, NO MARKING.  
RoHS PART: GREEN LABELING ON PACKAGING.

**SPECIFICATIONS**

CAP. VALUE	1500 pF
CAP. TOL.	+100, -0%
TEMP. CHAR.	X5U
OPERATING TEMP.	-55° TO +125°C
OPERATING VOLT.	100 WVDC

X-2015 Rev-0

<b>REVISION RECORD</b> Original Release C.O. <b>19980305-3-03</b> ADDED NOTES & SILVER FINISH. S.M. 05-20-05 <b>20050504-6-02</b>	<b>0</b>	<b>1</b>	<b>--TOLERANCES--</b> Unless Otherwise Specified	Title <b>SHOULDER  FEED-THRU</b>	
	DECIMAL ± .031 [0.79]		Drawn <b>S.M. 03-10-98</b>		
	ANGLES ±		Approved <b>J.Mc. 03-10-98</b>	<b>A</b> <b>2463-002-X5U0-152P</b>	
	<b>TUSONIX</b> TUCSON, ARIZONA				