

# Thick Film, Rectangular Resistor/Capacitor Chip

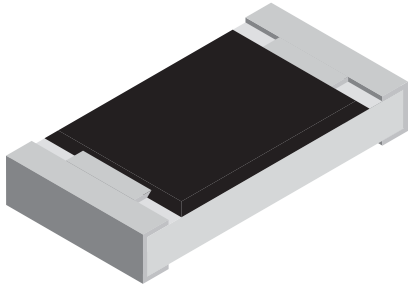

## FEATURES

- Single component reduces board space and component counts
- Choice of Dielectric Characteristics X7R or Y5U
- Wrap around termination
- Thick film Resistor/Capacitor element
- Inner electrode protection
- Flow & Reflow solderable
- Automatic placement capability, standard size
- Lead (Pb)-Free version is RoHS Compliant



RoHS\*  
COMPLIANT

STANDARD ELECTRICAL SPECIFICATIONS											
GLOBAL MODEL	SIZE		RESISTOR				CAPACITOR				
	INCH	METRIC	POWER RATING P <sub>70°C</sub> W	TEMPERATURE COEFFICIENT ppm/°C	TOL %	VALUE RANGE Ω	DIELECTRIC	TEMPERATURE COEFFICIENT %	TOL. %	VOLTAGE RATING VDC	VALUE RANGE pF
CRCC1206	1206	3216	0.125	200	5	10R – 1M0	X7R	± 15	20	50	10 - 270
CRCC1206	1206	3216	0.125	200	5	10R – 1M0	Y5U	+ 22, - 56	20	50	270 – 1800
<b>RESISTOR</b>						<b>CAPACITOR</b>					
<ul style="list-style-type: none"> <li>• Operating Temperature Range: - 55°C to + 125°C</li> <li>• Technology: thick film</li> </ul>						<ul style="list-style-type: none"> <li>• Operating Temperature Range: X7R - 55°C to + 125°C Y5U - 30°C to + 85°C</li> <li>• Maximum Dissipation Factor: 2.5%</li> </ul>					

- Packaging: see appropriate catalog or web page
- Power rating depends on the maximum temperature at the solder point, the component placement density and the substrate material

TECHNICAL SPECIFICATIONS				
PARAMETER	UNIT	RESISTOR	X7R CAPACITOR	Y5U CAPACITOR
Rated Dissipation at 70°C	W	0.125	–	–
Capacitor Voltage Rating	V	–	50	50
Dielectric Withstanding Voltage (5 seconds, 50mA Charge)	V <sub>dc</sub>	–	125	125
Category Temperature Range	°C	- 55 / + 155	- 55 / + 125	- 30 / + 85
Insulation Resistance	Ω	> 10 <sup>10</sup>	> 10 <sup>10</sup>	> 10 <sup>10</sup>
Weight / 1000 pieces	g	0.65	2	5.5

### GLOBAL PART NUMBER INFORMATION

New Global Part Numbering: CRCC1206472J220MTF (preferred part numbering format)

C	R	C	C	1	2	0	6	4	7	2	J	2	2	0	M	T	F
---	---	---	---	---	---	---	---	---	---	---	---	---	---	---	---	---	---

GLOBAL MODEL <b>CRCC1206</b>	RESISTANCE VALUE 2 digit significant figure, followed by a multiplier <b>100</b> = 10Ω <b>683</b> = 68KΩ <b>105</b> = 1.0MΩ	RES. TOLERANCE <b>F</b> = ± 1% <b>G</b> = ± 2% <b>J</b> = ± 5%	CAPACITANCE VALUE (pF) 2 digit significant figure, followed by a multiplier <b>100</b> = 10pF <b>271</b> = 270pF <b>182</b> = 1800pF	CAP. TOLERANCE <b>K</b> = ± 10% <b>M</b> = ± 20%	PACKAGING <b>EA</b> = Lead Free, T/R (4000 pcs) <b>TF</b> = TinLead, T/R (4000 pcs)
---------------------------------	---	---	--	--	---

Historical Part Number example: CRCC1206472J220MR02 (will continue to be accepted)

CRCC1206	472	J	220	M	R02
MODEL	RESISTANCE VALUE	RES. TOLERANCE	CAPACITANCE VALUE	CAP. TOLERANCE	PACKAGING

\* Pb containing terminations are not RoHS compliant, exemptions may apply

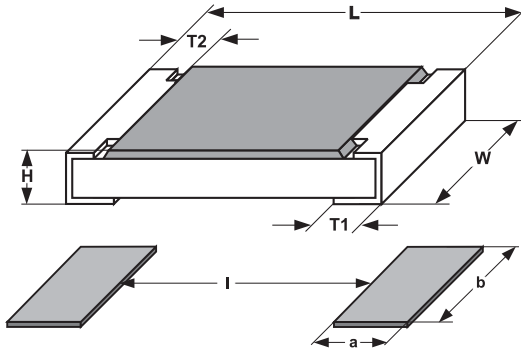
**DIMENSIONS**

SIZE		DIMENSIONS [in millimeters]				
INCH	METRIC	L	W	H	T1	T2
1206	3216	3.2 ± 0.15	1.6 ± 0.15	0.55 ± 0.15	0.5 ± 0.25	0.5 ± 0.25

SIZE		SOLDER PAD DIMENSIONS [in millimeters]					
		REFLOW SOLDERING			WAVE SOLDERING		
INCH	METRIC	a	b	l	a	b	l
1206	3216	0.9	1.7	2.0	1.1	1.7	2.2

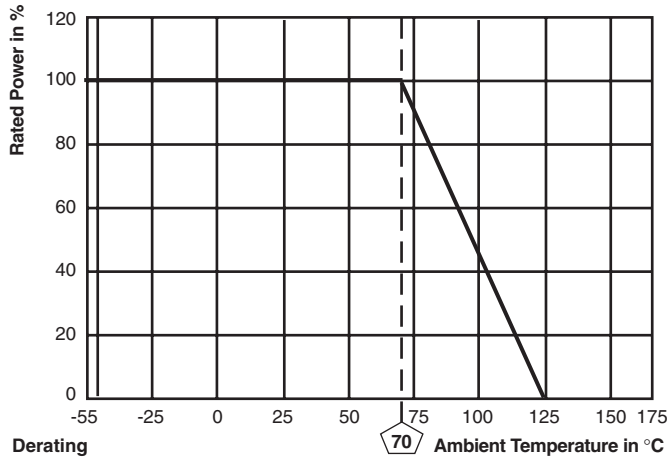
**SCHEMATIC**

<b>PERFORMANCE</b>			
TEST	CONDITIONS OF TEST	TEST RESULTS	
		R	C
Endurance Test at 70°C MIL-Std-202 Method 108	1000 hours at 70°C, 1.5 hours "ON", 0.5 hours "OFF"	± (5% + 2Ω)	± 20%
Dielectric Withstanding Voltage MIL-Std-202 Method 301	125Vdc, 5 seconds, 50mA charge	no physical damage	
Thermal Shock MIL-Std-202 Method 107	100 cycles, - 55 to + 125°C	± (5% + 2Ω)	± 20%
Moisture MIL-Std-202 Method 106	Omit steps 7A and B	± (5% + 2Ω)	± 20%
Resistance to Soldering Heat EIA 575	10 seconds at 260°C solder bath temperature	± (5% + 2Ω)	± 20%
High Temperature Exposure EIA 575	125°C for 100 hours	± (5% + 2Ω)	± 20%
Low Temperature Operation EIA 575	1 hour at - 55°C then 45 minutes at 50V	± (5% + 2Ω)	± 20%
Solderability & Leaching EIA 575 3.12	Condition C	95% Coverage	

**APPLICABLE SPECIFICATIONS**

- IPC Standards
- EIA 575



## Disclaimer

All product specifications and data are subject to change without notice.

Vishay Intertechnology, Inc., its affiliates, agents, and employees, and all persons acting on its or their behalf (collectively, "Vishay"), disclaim any and all liability for any errors, inaccuracies or incompleteness contained herein or in any other disclosure relating to any product.

Vishay disclaims any and all liability arising out of the use or application of any product described herein or of any information provided herein to the maximum extent permitted by law. The product specifications do not expand or otherwise modify Vishay's terms and conditions of purchase, including but not limited to the warranty expressed therein, which apply to these products.

No license, express or implied, by estoppel or otherwise, to any intellectual property rights is granted by this document or by any conduct of Vishay.

The products shown herein are not designed for use in medical, life-saving, or life-sustaining applications unless otherwise expressly indicated. Customers using or selling Vishay products not expressly indicated for use in such applications do so entirely at their own risk and agree to fully indemnify Vishay for any damages arising or resulting from such use or sale. Please contact authorized Vishay personnel to obtain written terms and conditions regarding products designed for such applications.

Product names and markings noted herein may be trademarks of their respective owners.