



# Low Cost VMEbus Interface Controller Family

## Features

- 80-Mbyte-per-second block transfer rates
- All VME64 transactions provided, including A64/D64, A40/MD32 transfers
- Auto Slot ID
- CR/CSR space
- All standard (Rev. C) VMEbus transactions implemented
- VMEbus Interrupter
- No local CPU required
- Programmable from VMEbus, serial PROM, or local bus
- DRAM controller, including refresh
- Local I/O controller
- Flexible VMEbus address scheme
- User-configured VMEbus response
- 64-pin TQFP, 10x10 mm (CY7C960A)

## Functional Description

The CY7C960A Slave VMEbus Interface Controller provides the board designer with an integrated, full-featured VME64 interface. This 64-pin device can be programmed to handle every transaction defined in the VME64 specification.

The CY7C960A contains all the circuitry needed to control large DRAM arrays and local I/O circuitry without the intervention of a local CPU. There are no registers to read or write, no complex command blocks to be constructed in memory. The CY7C960A simply fetches its own configuration parameters during the power-on reset period. After reset the CY7C960A responds appropriately to VMEbus activity and controls local circuitry transparently.

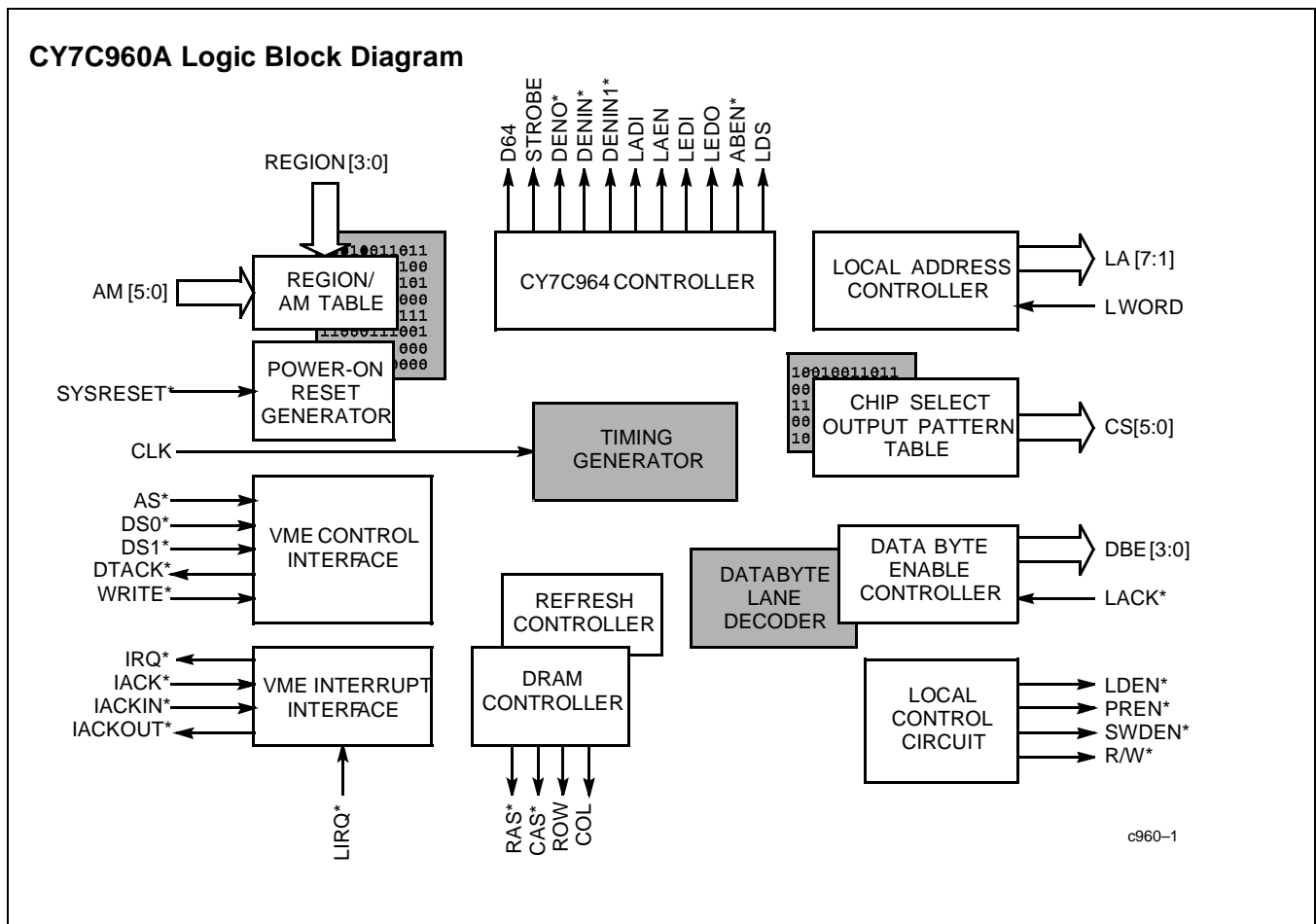

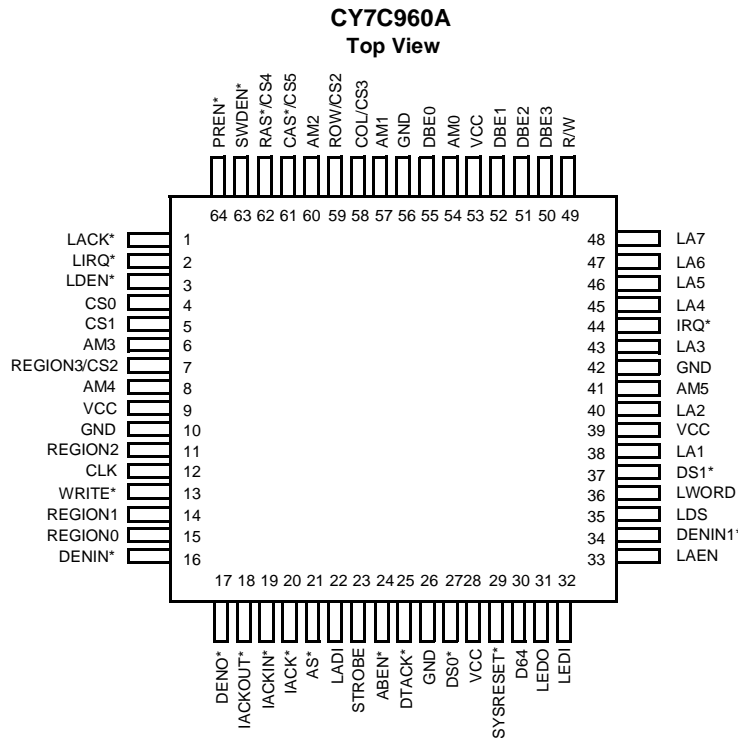
**Pin Configuration**

**Functional Description** (continued)

The CY7C960A controls a bridge between the VMEbus and local DRAM and I/O. Once programmed, the CY7C960A provides activities such as DRAM refresh and local I/O handshaking in a manner that requires no additional local circuitry. The VMEbus control signals are connected directly to the CY7C960A. The VMEbus address and data signals are connected to companion address/data transceivers which are controlled by the CY7C960A. The CY7C964 VMEbus Interface Logic Circuit is an ideal companion device: the CY7C964 provides a slice of data and address logic that has been optimized for VME64 transactions. In addition to providing the specified drive strength and timing for VME64 transactions, the CY7C964 contains all the circuitry needed to multiplex the address/data bus for multiplexed VMEbus transactions. It contains counters and latches needed during BLT operations; and it also contains address comparators which can be used in the board's Slave Address Decoder. For a 6U or 9U application, four CY7C964 devices are controlled by a single CY7C960A. For 3U applications, the CY7C960A controls two CY7C964 devices and an address latch.

The design of the CY7C960A makes it unnecessary to know the details of the VMEbus transaction timing and protocol. The complex VMEbus activities are translated by CY7C960A to simple local cycles involving a few familiar control signals. Similarly, it is not necessary to understand the operation of the companion device, CY7C964: all control sequences for the

part are generated automatically by the CY7C960A in response to VMEbus or local activity. If more information is desired, consult the CY7C964 chapter in the *VMEbus Interface Handbook*.

VMEbus transactions supported by the CY7C960A include D8, D16, D32 (incl. UAT), MD32, D64, A16, A24, A32, A40, A64 single-cycle and block-transfer reads and writes, Read-Modify-Write cycles (incl. multiplexed), and Address-only (with or without Handshake). The CY7C960A functions as a VMEbus Interrupter, and supports the new Auto Slot ID standard and CR/CSR space. The CY7C960A also handles LOCK cycles, although full LOCK support is not possible within the constraints of the CY7C960A pinout.

On the local side, no CPU is needed to program the CY7C960A, nor to manage transactions. All programmable parameters are initialized through the use of either the VMEbus, a serial PROM, or some other local circuit. As the CY7C960A incorporates a reliable power-on reset circuit, parameters are self-loaded by the device at power-up or after a system reset. If the VMEbus is used to provide parameters, a VMEbus Master provides the programming information using a protocol, described in the handbook, which is compliant with the Auto Slot ID protocol from the new VME64 specification.

To assist in generating the configuration file, a Windows™-based program, WinSvic Software, is available on the web which guides the user through the process of selecting appropriate options. Contact your Sales Office for further details.

System Diagram Using the CY7C960A

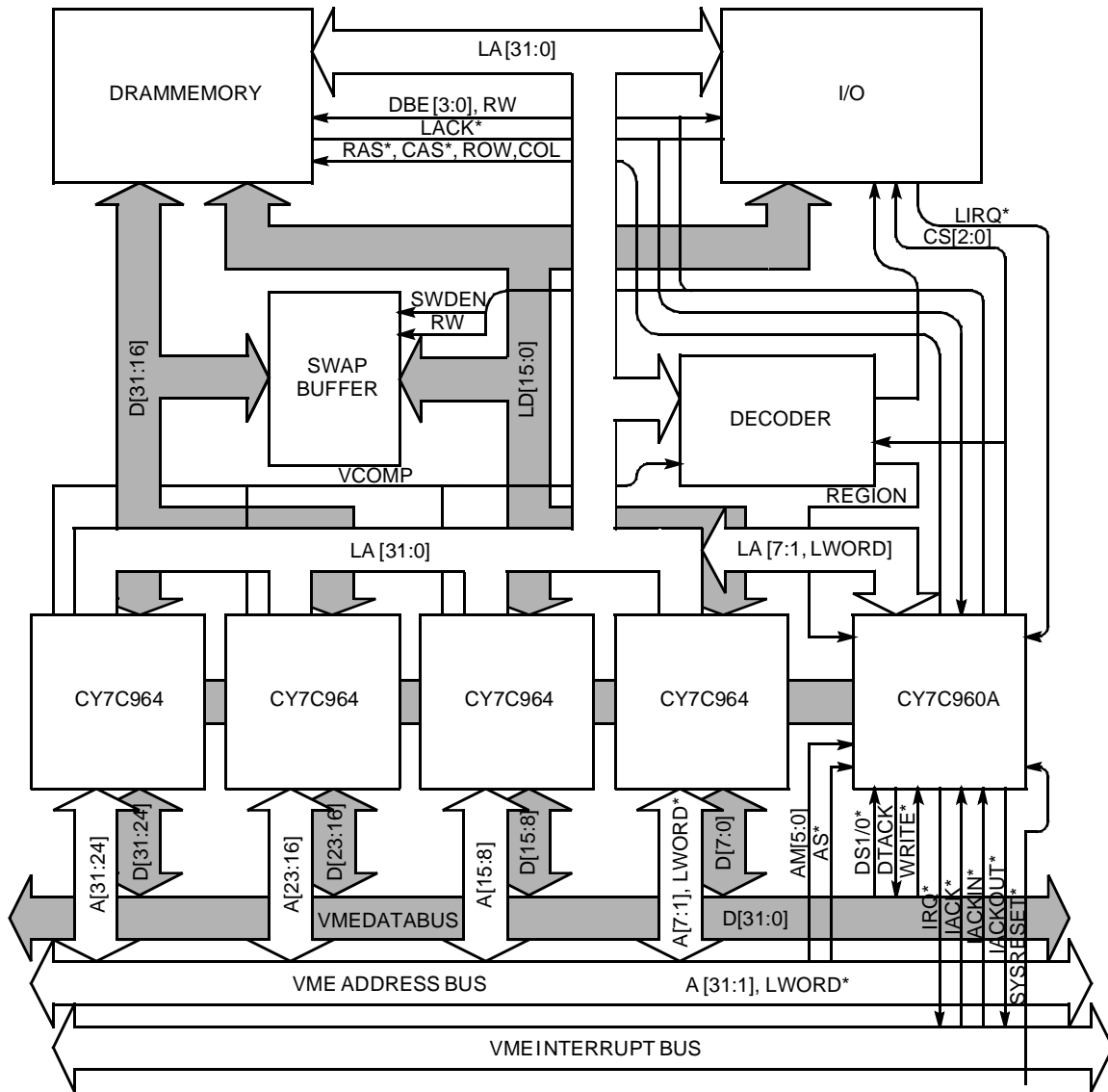

**DC Specifications - VMEbus Signals AS\*, DS1\*, DS0\*, DTACK\***

Parameter	Description	Test Conditions	Comm.	Industrial	Military	Units
V <sub>IH</sub>	Minimum High-Level Input Voltage		2.0	2.0	2.0	V
V <sub>IL</sub>	Maximum Low-Level Input Voltage		0.8	0.8	0.8	V
V <sub>OH</sub>	Minimum High-Level Output Voltage	V <sub>CC</sub> = Min., I <sub>OH</sub> =	2.4 -16 mA	2.4 -10 mA	2.4 -9 mA	V
V <sub>OL</sub>	Maximum Low-Level Output Voltage	V <sub>CC</sub> = Min., I <sub>OL</sub> =	0.6 64 mA	0.6 60 mA	0.6 52 mA	V
I <sub>L</sub>	Maximum Input Leakage Current	V <sub>CC</sub> = Max., GND < V <sub>IN</sub> < V <sub>CC</sub>	±5	±5	±5	μA
V <sub>IK</sub>	Input Clamp Voltage	V <sub>CC</sub> = Min., I <sub>IN</sub> = -18 mA	-1.2	-1.2	-1.2	V
I <sub>OZ</sub>	Maximum Output Leakage Current	V <sub>CC</sub> = Max. GND ≤ V <sub>OUT</sub> ≤ V <sub>CC</sub> Outputs Disabled	±10	±10	±10	μA

**DC Specifications - VMEbus Signals AM5, AM4, AM3, AM2, AM1, AM0, IRQ\*, Write**

Parameter	Description	Test Conditions	Comm.	Industrial	Military	Units
V <sub>IH</sub>	Maximum High-Level Input Voltage		2.0	2.0	2.0	V
V <sub>IL</sub>	Maximum Low-Level Input Voltage		0.8	0.8	0.8	V
V <sub>OH</sub>	Minimum High-Level Output Voltage	V <sub>CC</sub> = Min., I <sub>OH</sub> =	2.4 -16 mA	2.4 -10 mA	2.4 -9 mA	V
V <sub>OL</sub>	Minimum Low-Level Output Voltage	V <sub>CC</sub> = Min., I <sub>OL</sub> =	0.6 48 mA	0.6 44 mA	0.6 38 mA	V
I <sub>L</sub>	Maximum Input Leakage Current	V <sub>CC</sub> = Max., GND < V <sub>IN</sub> < V <sub>CC</sub>	±5	±5	±5	μA
V <sub>IK</sub>	Input Clamp Voltage	V <sub>CC</sub> = Min., I <sub>IN</sub> = -18 mA	-1.2	-1.2	-1.2	V
I <sub>OZ</sub>	Maximum Output Leakage Current	V <sub>CC</sub> = Max. GND < V <sub>OUT</sub> < V <sub>CC</sub> Outputs Disabled	±5	±5	±10	μA

**DC Specifications - All Other Output Signals<sup>[1]</sup>**

Parameter	Description	Test Conditions	Comm.	Industrial	Military	Units
V <sub>IH</sub>	Maximum High-Level Input Voltage		2.0	2.0	2.0	V
V <sub>IL</sub>	Maximum Low-Level Input Voltage		0.8	0.8	0.8	V
V <sub>OH</sub>	Minimum High-Level Output Voltage	V <sub>CC</sub> = Min., I <sub>OH</sub> =	2.4 -16 mA	2.4 -10 mA	2.4 -9 mA	V
V <sub>OL</sub>	Minimum Low-Level Output Voltage	V <sub>CC</sub> = Min., I <sub>OL</sub> =	0.6 20 mA	0.6 18 mA	0.6 16 mA	V
I <sub>L</sub>	Maximum Input Leakage Current	V <sub>CC</sub> = Max., GND < V <sub>IN</sub> < V <sub>CC</sub>	±5	±5	±5	μA
V <sub>IK</sub>	Input Clamp Voltage	V <sub>CC</sub> = Min., I <sub>IN</sub> = -18 mA	-1.2	-1.2	-1.2	V
I <sub>OZ</sub>	Maximum Output Leakage Current	V <sub>CC</sub> = Max. GND < V <sub>OUT</sub> < V <sub>CC</sub> Outputs Disabled	±5	±5	±10	μA

**Note:**

1. Some signals have an on-chip pull-up or pull-down resistors. For these signals I<sub>OZ</sub> value is modified.

**Capacitance - All Signals**

Parameters	Description	Test Conditions	Max.	Units
$C_{IN}$	Input Capacitance	$T_A = 25^\circ\text{C}$ , $f = 1\text{ MHz}$ , $V_{CC} = 5.0\text{V}$	15	pF
$C_{OUT}$	Output Capacitance		15	pF

**Pullup/Pulldown Current - All Signals**

Parameters	Description	Test Conditions	Typ.	Max.
$I_{PU}$	Input Pull-up Current	$T_A = -55^\circ\text{C}$ , $V_{CC} = 5.5\text{V}$ $V_{IN} = \text{GND}$	100 $\mu\text{A}$	250 $\mu\text{A}$
$I_{PU}$	Input Pull-up Current	$T_A = -55^\circ\text{C}$ , $V_{CC} = 5.5\text{V}$ $V_{IN} = V_{CC}$	100 $\mu\text{A}$	250 $\mu\text{A}$

**Operating Current (CY7C960A)**

Parameters	Description	Test Conditions	Max.	Units
$I_{DD}$	Maximum Operating Current	No external DC load	100	mA

**Related Documents**

*VMEBus Interface Handbook*

**Ordering Information**

Ordering Code	Package Name	Package Type	Operating Range
CY7C960A-ASC	A64	10x10 mm body 64-Lead Plastic Thin Quad Flatpack	Commercial
CY7C960A-NC	N65	14x14 mm body 64-Lead Plastic Thin Quad Flatpack	
CY7C960A-UM	U65	14x14 mm body 64 lead Ceramic Quad Flatpack	Military
CY7C960A-UMB	U65	14x14 mm body 64 lead Ceramic Quad Flatpack	

Windows is a trademark of Microsoft Corporation.

Document #: 38-00250-E

Package Diagrams

64-Pin Thin Plastic Quad Flat Pack (10 x 10 x 1.4 mm) A64

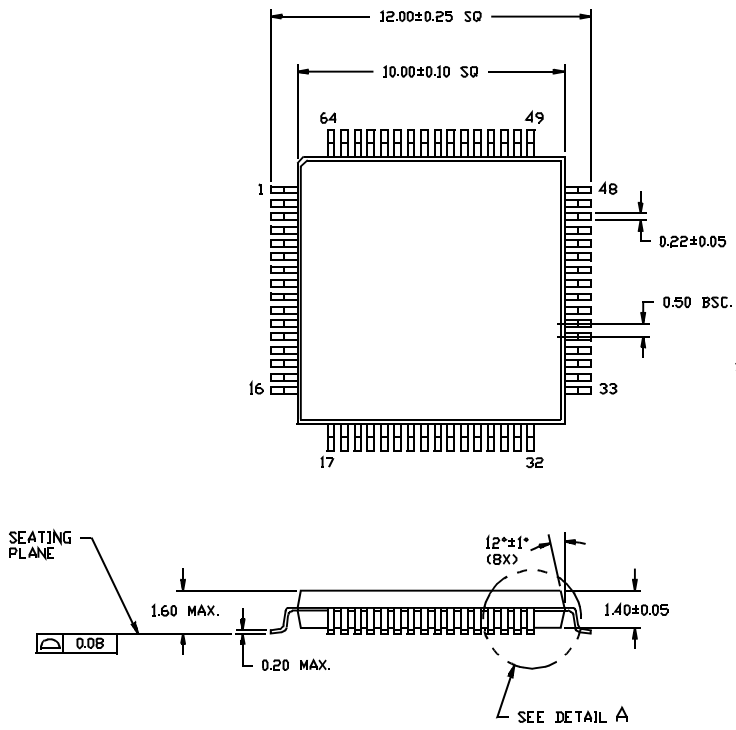

DIMENSIONS ARE IN MILLIMETERS

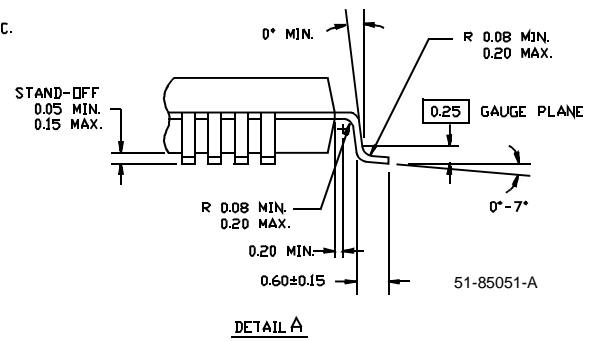

Package Diagrams (continued)

64-Lead Plastic Thin Quad Flatpack N65

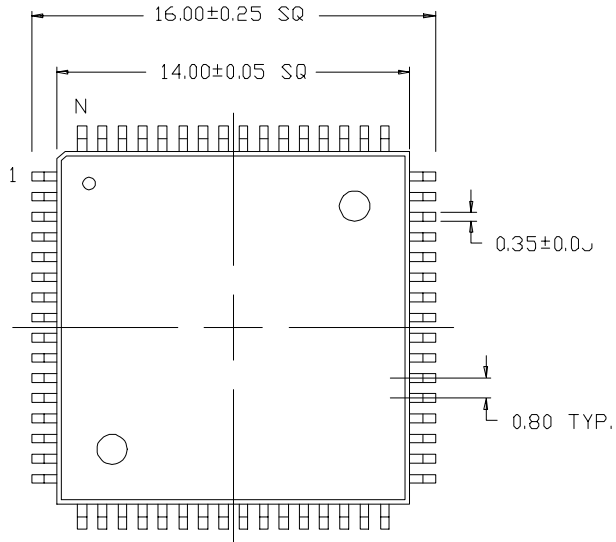

DIMENSIONS IN MILLIMETERS  
LEAD COPLANARITY 0.100 MAX.

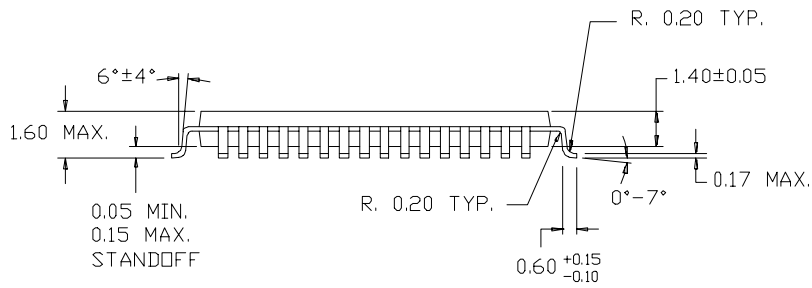

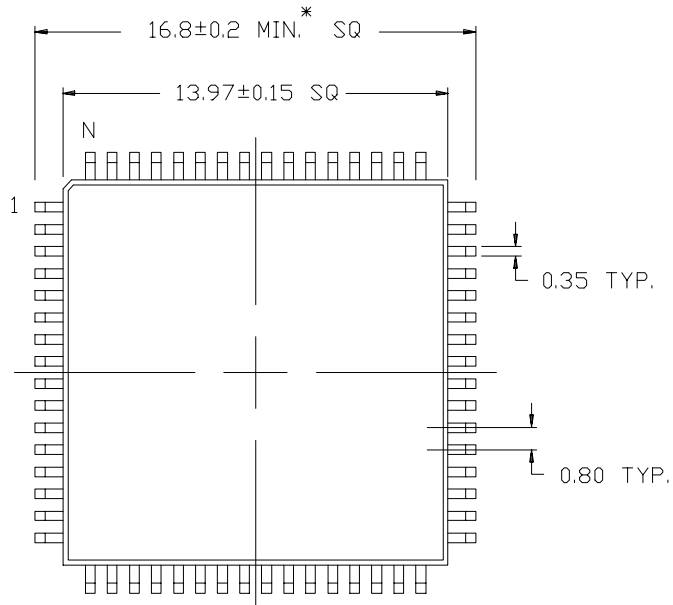
**Package Diagrams (continued)**
**64-Lead Ceramic Quad Flatpack (Cavity Up) U65**

DIMENSIONS IN MILLIMETERS  
 LEAD COPLANARITY 0.102 MAX.  
 DIMENSION    MIN.  
                   MAX.

