

**PIN CONFIGURATION<sup>(1)</sup>**  
**160-PIN PLASTIC QUAD FLATPACK (CAVITY DOWN)**  
**TOP VIEW**

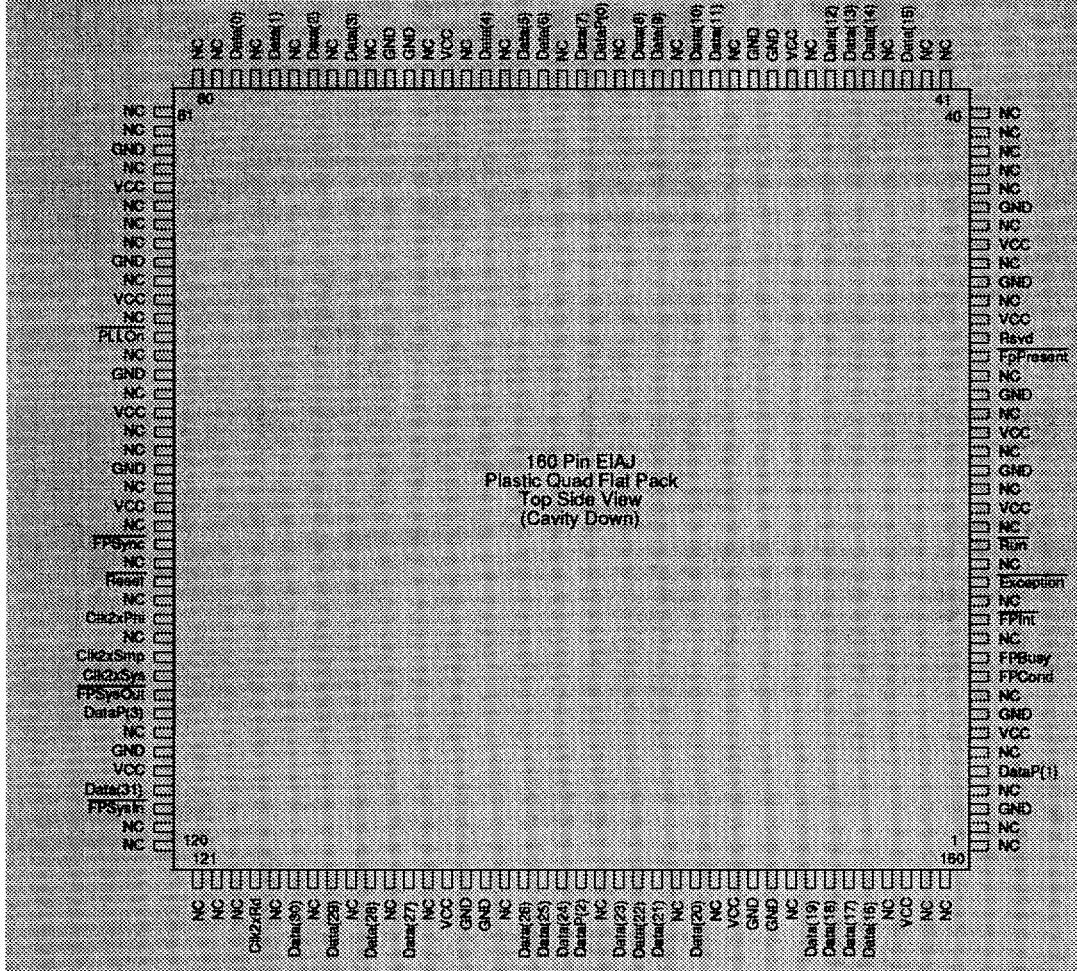

2679 Rev 08a

**NOTE:**

1. Reserved pins must not be connected.
2. NC are no-connects and must not be connected.

**ORDERING INFORMATION**

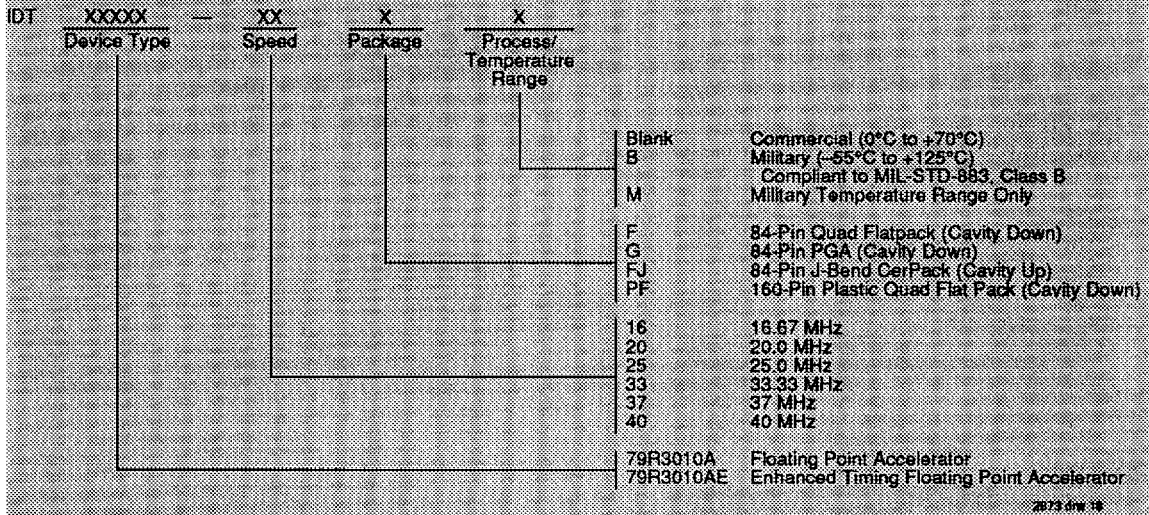

2073.dwg 18

**VALID COMBINATIONS**

IDT 79R3010A - 16, 20	All packages
79R3010A - 16, 20B, M	G, F
79R3010AE - 25, 33 B, M	G, F
79R3010AE - 25, 33, 37, 40	All Packages

**External R3000 Condition Code Pin**

The R3000 input CPC0 is available as a pin on the module. During run cycles, this pin acts as a Condition Code test pin, so the R3000 can do a Test and Branch in a single cycle based on its state.



**SPECIFICATIONS****CPU**

R3000

**User Selectable Options via Jumpers:**

Streaming/No Streaming

Store Partial On/Off

**Floating Point**

R3010 optional in either configuration. If present, connected to INT2.

**Cache Ram**

64 KB I-cache (16K words)

64 KB D-cache (16K words)

**Cacheable Address Space**

4 GBytes

**MP Support**

Cache invalidate supported

**Block Refill**

8 word (or single word)

**Endianness**

Big Endian

**Read/Write Buffers**

1 - Word Read Buffer

4 - Word Write Buffer

**Interrupts**

6 User Interrupts, synchronized with SYSOUTA:D in an on-board register.

**I/O characteristics**

TTL levels from FCT logic devices, PALs and R3000

**Power Supply**

4.5 amps (typical) at 5.0 V, 25°C, at 33MHz.

**Environmental Conditions**

Ambient temperature 0°C to +50°C.

Relative Humidity 5% to 95%

**Clock Frequencies**

20, 25 and 33 MHz

**Interconnection**

195 18-mil round pins on 100-mil centers

Mating connector: Samtec SS-1 series socket strips or equivalent.

MECHANICAL OUTLINE

7RS107 TOP VIEW

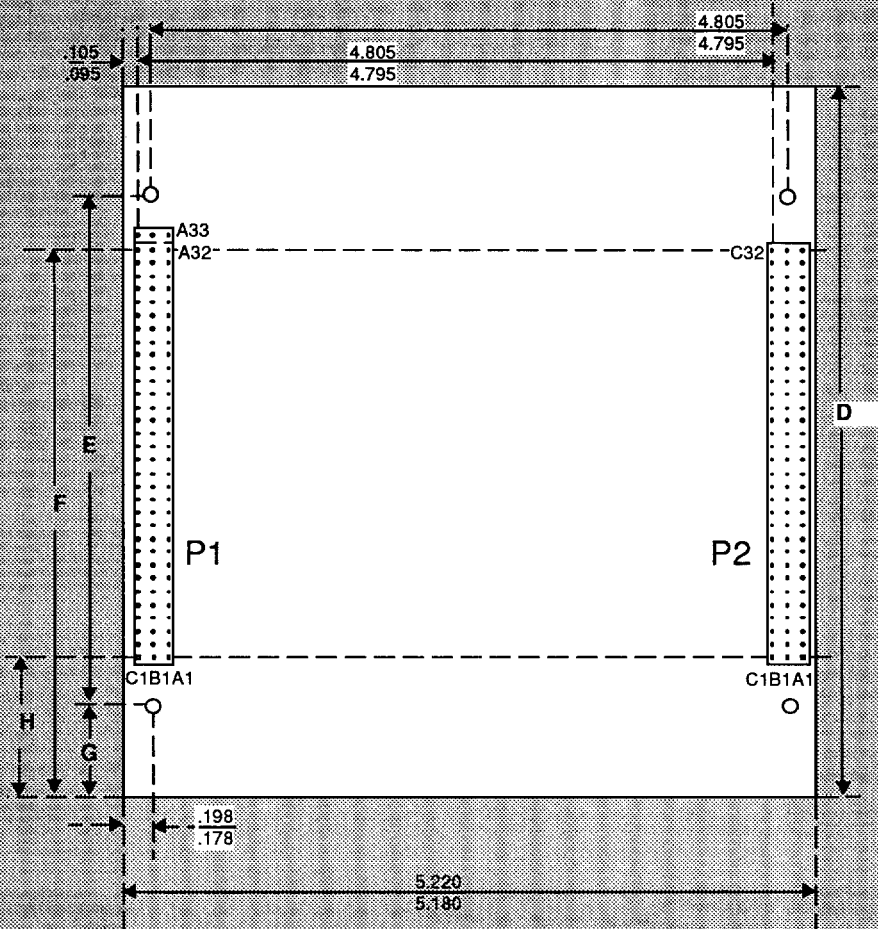

	7RS107-66		7RS108-88		7RS109-66	
	Min.	Max.	Min.	Max.	Min.	Max.
D	5.180	5.220	5.390	5.420	5.180	5.220
E	3.545	3.555	3.545	3.555	3.545	3.555
F	4.145	4.155	4.245	4.255	4.145	4.155
G	0.815	0.835	0.915	0.935	0.815	0.835
H	1.045	1.055	1.145	1.155	1.045	1.055
K		0.30		0.30		0.30
L		0.20		0.15		0.20

NOTES:

1. All dimensions in inches unless otherwise noted.
2. The 7RS107, 108 and 109 are a family of modules. Dimensions for all three are listed here, so that you can add flexibility by accepting all three modules.
3. P1 on the 7RS107 has three rows of 33 pins, while P1 on the 7RS108/9 has three rows of 32 pins.
4. Mounting holes are 0.109 ± .002. Note that mounting holes are offset from center line of connector.
5. Holes take #2 mounting hardware.
6. Pins are 0.018 diameter on 0.100 spacing on both axis.
7. To connect the modules use strip connectors Rob. Nug. SBE-32-S-TG for 32 pins, Rob. Nug. SBE-33-S-TG for 33 pins or equivalent.





**MECHANICAL OUTLINE**

**7RS107 SIDE VIEW**

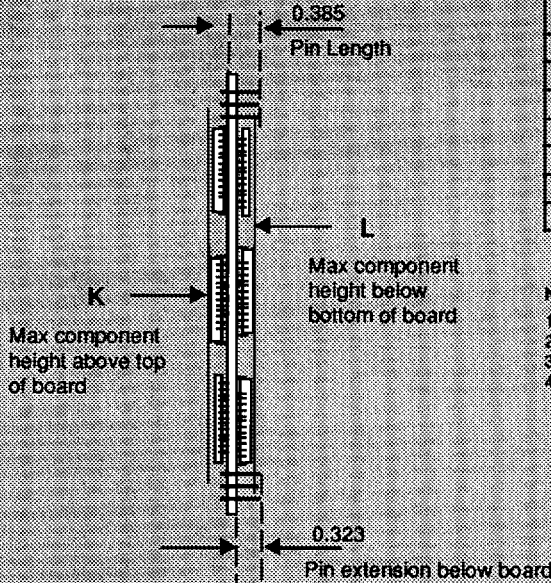

	7RS107-66		7RS108-88		7RS109-66	
	Min.	Max.	Min.	Max.	Min.	Max.
<b>D</b>	5.180	5.220	5.380	5.420	5.180	5.220
<b>E</b>	3.545	3.555	3.545	3.555	3.545	3.555
<b>F</b>	4.145	4.155	4.245	4.255	4.145	4.155
<b>G</b>	0.815	0.835	0.915	0.935	0.815	0.835
<b>H</b>	1.045	1.055	1.145	1.155	1.045	1.055
<b>K</b>		0.30		0.30		0.30
<b>L</b>		0.20		0.15		0.20

**NOTES:**

1. All dimensions in inches unless otherwise noted.
2. Pins are 0.018 diameter on 0.100 spacing on both axis.
3. Board thickness 0.062 ± .007
4. To connect the modules use strip connectors Rob. Nug. SBE-32-9-TG for 32 pins, Rob. Nug. SBE-33-5-TG for 33 pins or equivalent

**CUSTOM OPTIONS**

Some features of the 7RS107 can be modified by special order. Contact your IDT sales office for details. Examples of possible modifications include: initialization mode for the R3000, endian option, size of block refill, pin length, style, and plating; special marking; additional burn-in, and socketing of the CPU and/or FPA.

**FOR DETAILED DESIGN INFORMATION, CONTACT IDT AND ASK FOR THE 7RS107 DESIGNER'S GUIDE.**

**R3000 MODULE FOR HIGH PERFORMANCE CPUS:**

7RS108 Module. Actual Size 5.2" x 5.4"

The module is constructed using surface mount devices on a 5.2" by 5.4" epoxy laminate board, and is connected to the user's system via 192 pins located in two pin row regions on the board.

**SIGNALS PROVIDED ON MODULE PINS**

Signal Name	Type	Description
EXTOSC	I	Optional input for external oscillator.

**SPECIFICATIONS****CPU**

R3000

**Floating Point**

R3010 optional in either configuration. If present, connected to INT2.

**Cache Ram**256 KB I-cache (64K words)  
256 KB D-cache (64K words)**Cacheable Address Space**

4 GBytes

**MP Support**

Cache invalidate supported

**Block Refill**

8 or 16 - word (or single word)

**Endianness**

Big Endian

**Read/Write Buffers**1 - Word Read Buffer  
4 - Word Write Buffer**Interrupts**6 User Interrupts, synchronized with SYSOUTA:D  
in an on-board register.**I/O characteristics**

TTL levels from FCT logic devices, PALs and R3000

**Power Supply**

3.5 amps (typical) at 5.0 V, 25°C, at 25MHz.

**Environmental Conditions**Ambient temperature 0°C to +50°C,  
Relative Humidity 5% to 95%**Clock Frequencies**

20 and 25 MHz

**Interconnection**192 18-mil round pins on 100-mil centers  
Mating connector: Samtec SS-1 series  
socket strips or equivalent.**User Selectable Options via jumpers:**8 word or 16 word block refill  
Streaming/No Streaming  
Store Partial On/Off**Other Options:**

The 7RS108 may be factory programmed with different initialization options or altered in other ways for special needs. Please contact your IDT sales office if you are interested in a variation of the standard 7RS108 module.

**C**

MECHANICAL OUTLINE

7RS108 TOP VIEW

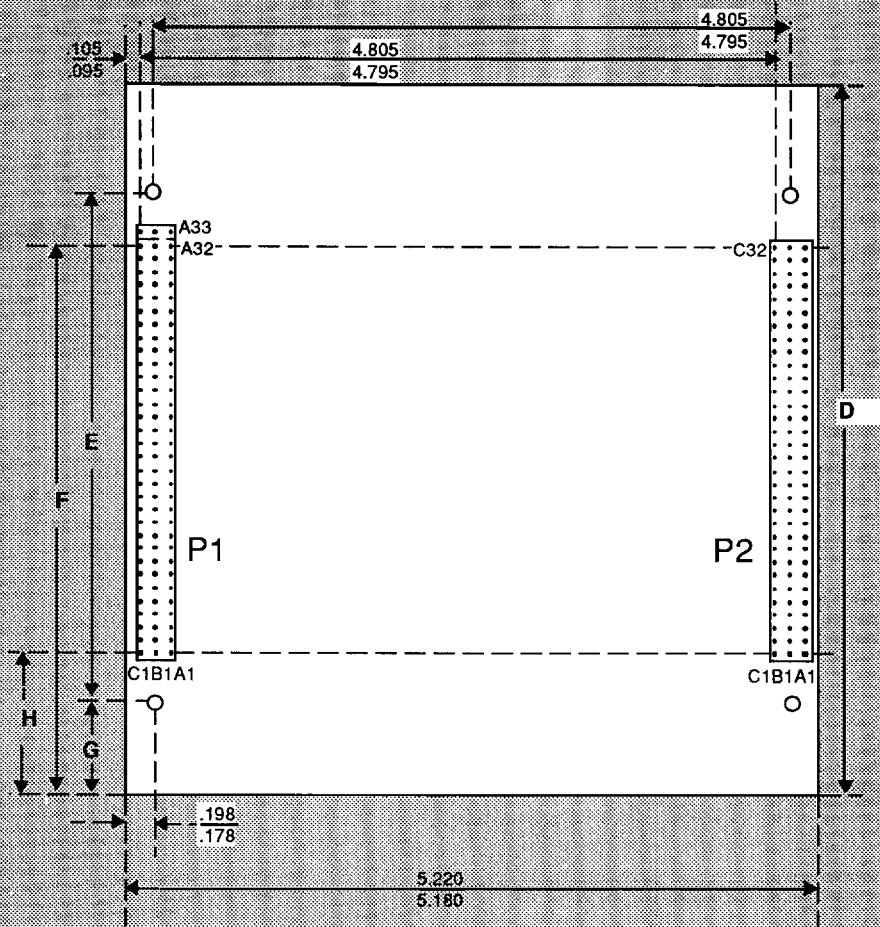

	7RS107-66		7RS108-66		7RS109-66	
	Min.	Max.	Min.	Max.	Min.	Max.
D	5.180	5.220	5.380	5.420	5.180	5.220
E	3.545	3.555	3.545	3.555	3.545	3.555
F	4.145	4.155	4.245	4.255	4.145	4.155
G	0.815	0.835	0.915	0.935	0.815	0.835
H	1.045	1.055	1.145	1.155	1.045	1.055
K		0.30		0.30		0.30
L		0.20		0.15		0.20

NOTES:

1. All dimensions in inches unless otherwise noted.
2. The 7RS107, 108, and 109 are a family of modules. Dimensions for all three are listed here, so that you can add flexibility by accepting all three modules.
3. P1 on the 7RS107 has three rows of 33 pins, while P1 on the 7RS108/9 has three rows of 32 pins.
4. Mounting holes are 0.109 ± .002. Note that mounting holes are offset from center line of connector.
5. Holes take #2 mounting hardware.
6. Pins are 0.018 diameter on 0.100 spacing on both axis.
7. To connect the modules use strip connectors Rob. Nug. SBE-32-S-TG for 32 pins, Rob. Nug. SBE-33-S-TG for 33 pins or equivalent.

**MECHANICAL OUTLINE**

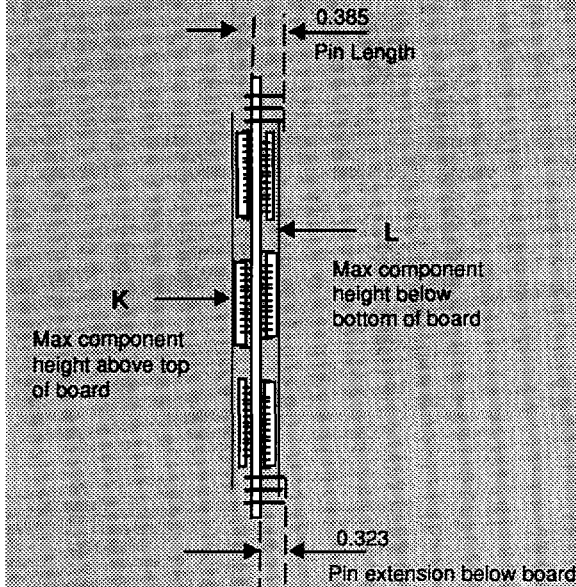

	7RS107-66		7RS108-66		7RS109-66	
	Min.	Max.	Min.	Max.	Min.	Max.
D	5.180	5.220	5.380	5.420	5.180	5.220
E	3.545	3.555	3.545	3.555	3.545	3.555
F	4.145	4.155	4.245	4.255	4.145	4.155
G	0.815	0.835	0.915	0.935	0.815	0.835
H	1.045	1.055	1.145	1.155	1.045	1.055
K		0.30		0.30		0.30
L		0.20		0.15		0.20

**NOTES:**

1. All dimensions in inches unless otherwise noted.
2. Pins are 0.018 diameter on 0.100 spacing on both axis.
3. Board thickness 0.062 ± .007.
4. To connect the modules use strip connectors Rob. Nug. SBE-32-S-TG for 32 pins, Rob. Nug. SBE-33-S-TG for 33 pins or equivalent.

**CUSTOM OPTIONS**

Some features of the 7RS108 can be modified by special order. Contact your IDT sales office for details. Possible modifications include: initialization mode for the R3000, endian option, size of block refill, instruction streaming, pin length, style, and plating; special marking; additional burn-in, and socketing of the CPU and/or FPA.

**ADDITIONAL INFORMATION**

For detailed design information, contact IDT and ask for the 7RS108 Designer's Guide.

**FEATURES:**

• Small size: 3.3" x 4.1"

7RS110 Module. Actual Size 3.3" x 4.1"

**SIGNALS PROVIDED ON MODULE PINS**

Signal Name	Type	Description
WPERR# **	OUT	Negative-true output used to indicate data parity error while write to memory operation.
RPERR# **	OUT	Negative-true output used to indicate data parity error while read from memory operation.



**SPECIFICATIONS****CPU**

R3000 in 7RS110-55; R3001 in 7RS110-54

**Floating Point**

R3010 optional in either configuration. If present, connected to INT1.

**Cache Ram**

7RS110-55:

32 KB each I and D-cache. (8K words)

7RS110-54

32 KB I-cache (8K words)

16 KB D-cache (4K words)

**Cacheable Address Space**

7RS110-55

4 GBytes

7RS110-54

0.5 GBytes

**MP Support**

7RS110-55

Cache invalidate supported

7RS110-54

Not supported

**Block Refill**

8 or 16 word (or single word)

**Endianess**

User programmable via module pin.

**Read/Write Buffers**

Both are one word deep.

**Interrupts**

6 User Interrupts, synchronized with SYSOUTA:D in an on-board register.

**I/O characteristics**

TTL levels from FCT logic devices, PALs and R3000

**Power Supply**

2.5 amps (typical) at 5.0 V, 25°C, at rated speed.

**Environmental Conditions**

Ambient temperature 0°C to +50°C.

Relative Humidity 5% to 95%

**Clock Frequencies**

7RS110-55

20, 25, and 33 MHz

7RS110-54

20 and 25 MHz

**Interconnection**

216 18-mil round pins on 100-mil centers

Mating connector: Samtec SS-1 series socket strips or equivalent.

**User Selectable Options**

**MECHANICAL OUTLINE**

**7RS110 TOP VIEW**

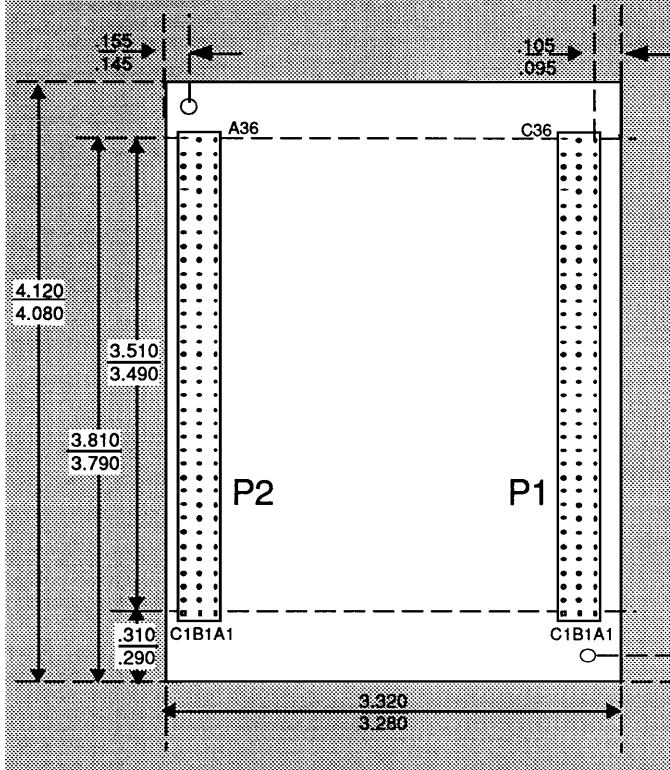

**7RS110 SIDE VIEW**

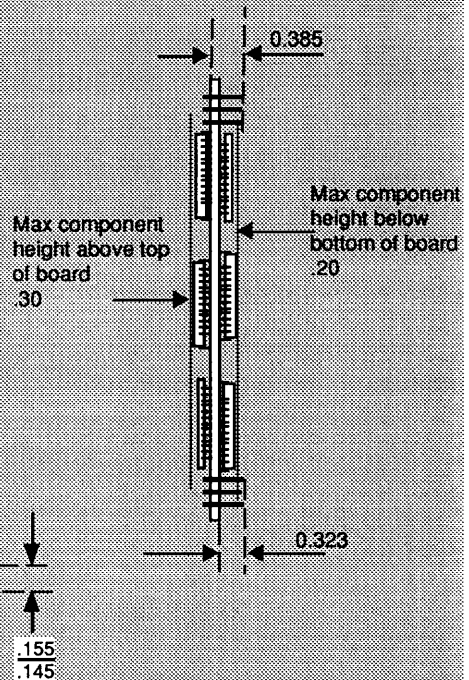

**NOTES:**

1. Mounting holes are 0.090±.002. Note that the mounting holes are offset from the center line of connector.
2. All dimensions in inches unless otherwise noted.
3. Pins are 0.018 diameter on 0.100 spacing on both axis.
4. Pin length = .385" (Extension below board = .323")
5. Board thickness 0.062 ± .007.
6. To connect the modules use strip connectors Rob. Nug. SBO-50P-D-100-TG for 36 pins or equivalent.



**ADDITIONAL INFORMATION**

For detailed design information, contact IDT and ask for the 7RS110 Designer's Guide.

**OTHER OPTIONS**

The 7RS110 may be factory programmed with different initialization options or altered in other ways for special needs. Please contact your IDT sales office if you are interested in a variation on the standard 7RS110 module.