

MC3405

Dual Operational Amplifier and Dual Comparator

The MC3405 contains two differential-input operational amplifiers and two comparators, each set capable of single supply operation. This operational amplifier-comparator circuit fulfills its applications as a general purpose product for automotive and consumer circuits as well as an industrial building block.

The MC3405 is specified over the commercial operating temperature range of 0° to +70°C.

- Operational Amplifier Equivalent in Performance to MC3403
- Comparator Similar in Performance to LM339
- Single Supply Operation: 3.0 V to 36 V
- Split Supply Operation: ± 1.5 V to ± 18 V
- Low Supply Current Drain
- Operational Amplifier is Internally Frequency Compensated
- Comparator TTL and CMOS Compatible

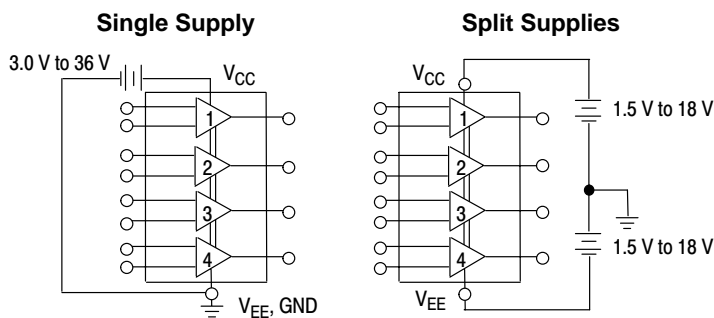

ON Semiconductor®

<http://onsemi.com>

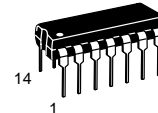

**P SUFFIX
CASE 646**

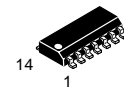

**SO-14
D SUFFIX
CASE 751A**

PIN CONNECTIONS

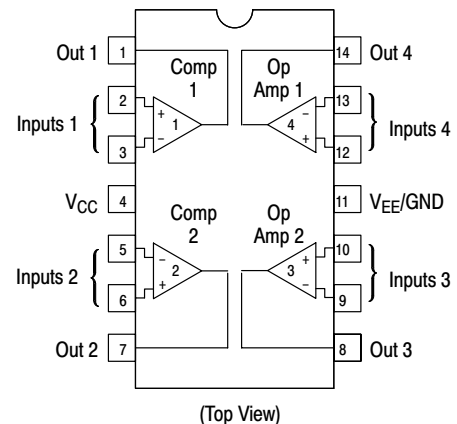

ORDERING INFORMATION

Device	Package	Shipping
MC3405P	Plastic DIP	??? Units/Rail
MC3405D	SO-14	??? Tape/Reel

MC3405

OPERATIONAL AMPLIFIER SECTION

MAXIMUM RATINGS

Rating	Symbol	Value	Unit
Power Supply Voltage - Single Supply Split Supplies	V_{CC} V_{CC}, V_{EE}	36 ± 18	Vdc
Input Differential Voltage Range	V_{IDR}	± 36	Vdc
Input Common Mode Voltage Range	V_{ICR}	± 18	Vdc
Operating Ambient Temperature Range	T_A	0 to +70	°C
Storage Temperature Range	T_{stg}	-55 to +125	°C
Operating Junction Temperature Range	T_J	150	°C

ELECTRICAL CHARACTERISTICS ($V_{CC} = 5.0$ V, $V_{EE} = \text{GND}$, $T_A = 25^\circ\text{C}$, unless otherwise noted.)

Characteristic	Symbol	Min	Typ	Max	Unit
Input Offset Voltage	V_{IO}	-	2.0	10	mV
Input Offset Current	I_{IO}	-	30	50	nA
Input Bias Current	I_{IB}	-	-200	-500	nA
Large-Signal, Open Loop Voltage Gain ($R_L = 2.0$ k Ω)	A_{VOL}	20	200	-	V/mV
Power Supply Rejection	PSR	-	-	150	$\mu\text{V/V}$
Output Voltage Range (Note 1) ($R_L = 10$ k Ω , $V_{CC} = 5.0$ V) ($R_L = 10$ k Ω , 5.0 V $\leq V_{CC} \leq 30$ V)	V_{OR}	3.3 $V_{CC} - 2.0$	3.5 $V_{CC} - 1.7$	- -	V_{pp}
Power Supply Current (Notes 2 and 3)	I_{CC}	-	2.5	7.0	mA
Channel Separation, $f = 1.0$ kHz to 20 kHz (Input Referenced)	-	-	-120	-	dB

ELECTRICAL CHARACTERISTICS ($V_{CC} = +15$ V, $V_{EE} = -15$ V, $T_A = 25^\circ\text{C}$, unless otherwise noted.)

Characteristic	Symbol	Min	Typ	Max	Unit
Input Offset Voltage ($T_A = T_{low} + T_{high}$) (Note 4)	V_{IO}	- -	2.0 -	10 12	mV
Average Temperature Coefficient of Input Offset Voltage	$\Delta V_{IO}/\Delta T$	-	15	-	$\mu\text{V}/^\circ\text{C}$
Input Offset Current ($T_A = T_{low}$ to T_{high}) (Note 4)	I_{IO}	- -	- -	50 200	nA
Input Bias Current ($T_A = T_{low}$ to T_{high}) (Note 4)	I_{IB}	- -	-200 -	-500 -800	nA
Input Common Mode Voltage Range	V_{ICR}	+13	$-V_{EE}$	-	Vdc
Large Signal, Open Loop Voltage Gain ($V_O = \pm 10$ V, $R_L = 2.0$ k Ω) ($T_A = T_{low}$ to T_{high}) (Note 4)	A_{VOL}	20 15	200 100	- -	V_{mV}
Common Mode Rejection	CMR	70	90	-	dB
Power Supply Rejection Ratio	PSRR	-	30	150	$\mu\text{V/V}$
Output Voltage ($R_L = 10$ k Ω) ($R_L = 2.0$ k Ω) ($R_L = 2.0$ k Ω , $T_A = T_{low}$ to T_{high}) (Note 4)	V_O	± 12 ± 10 ± 10	± 13.5 ± 13 -	- - -	Vdc
Output Short Circuit Current	I_{SC}	± 10	± 20	± 45	mA
Power Supply Current (Notes 2 and 3)	I_{CC}, I_{EE}	-	2.8	7.0	mA
Phase Margin	fm	-	60	-	Degrees
Small-Signal Bandwidth ($A_V = 1$, $R_L = 10$ k Ω , $V_O = 50$ mV)	BW	-	1.0	-	MHz

- NOTES:** 1. Output will swing to ground.
 2. Not to exceed maximum package power dissipation.
 3. For operational amplifier and comparator.
 4. $T_{low} = 0^\circ\text{C}$, $T_{high} = +70^\circ\text{C}$

MC3405

ELECTRICAL CHARACTERISTICS ($V_{CC} = +15\text{ V}$, $V_{EE} = -15\text{ V}$, $T_A = 25^\circ\text{C}$, unless otherwise noted.)

Characteristic	Symbol	Min	Typ	Max	Unit
Power Bandwidth ($A_V = 1$, $R_L = 2.0\text{ k}\Omega$, $V_O = 20\text{ V}_{pp}$, THD = 5%)	BWp	-	9.0	-	kHz
Rise Time/Fall Time	t_{TLH} , t_{THL}	-	0.35	-	μs
Overshoot ($A_V = 1$, $R_L = 10\text{ k}\Omega$, $V_O = 50\text{ mV}$)	os	-	20	-	%
Slew Rate	SR	-	0.6	-	$\text{V}/\mu\text{s}$

COMPARATOR SECTION

MAXIMUM RATINGS

Rating	Symbol	Value	Unit
Power Supply Voltage - Single Supply Split Supplies	V_{CC} V_{CC} , V_{EE}	36 ± 18	Vdc
Input Differential Voltage Range	V_{IDR}	± 36	Vdc
Input Common Mode Voltage Range	V_{ICR}	-0.3 to +36	Vdc
Sink Current	I_{Sink}	20	mA
Operating Ambient Temperature Range	T_A	0 to +70	$^\circ\text{C}$
Storage Temperature Range	T_{stg}	-55 to +125	$^\circ\text{C}$
Operating Junction Temperature Range	T_J	150	$^\circ\text{C}$

ELECTRICAL CHARACTERISTICS ($V_{CC} = 5.0\text{ V}$, $V_{EE} = \text{GND}$, $T_A = 25^\circ\text{C}$, unless otherwise noted.)

Characteristic	Symbol	Min	Typ	Max	Unit
Input Offset Voltage ($T_A = T_{low}$ to T_{high}) (Notes 1 and 2)	V_{IO}	-	2.0 -	10 12	mV
Average Temperature Coefficient of Input Offset Voltage	$\Delta V_{IO}/\Delta T$	-	15	-	$\mu\text{V}/^\circ\text{C}$
Input Offset Current ($T_A = T_{low}$ to T_{high}) (Note 1)	I_{IO}	-	50 -	100 200	nA
Input Bias Current ($T_A = T_{low}$ to T_{high}) (Note 1)	I_{IB}	-	-125 -	-500 -800	nA
Input Common Mode Voltage Range ($T_A = T_{low}$ to T_{high}) (Note 1)	V_{ICR}	0 0	$V_{CC} - 1.5$ $V_{CC} - 1.7$	$V_{CC} - 1.7$ $V_{CC} - 2.0$	VPP
Input Differential Voltage (All $V_{in} \geq 0\text{ Vdc}$)	V_{ID}	-	-	36	V
Large-Signal, Open Loop Voltage Gain ($R_L = 15\text{ k}\Omega$)	A_{VOL}	-	200	-	V/mV
Output Sink Current ($-V_{in} \geq 1.0\text{ Vdc}$, $+V_{in} = 0$, $V_O \leq 1.5\text{ V}$)	I_{Sink}	6.0	16	-	mA
Low Level Output Voltage ($+V_{in} = 0\text{ V}$, $-V_{in} = 1.0\text{ V}$, $I_{Sink} = 4.0\text{ mA}$) ($T_A = T_{low}$ to T_{high}) (Note 1)	V_{OL}	-	350 -	500 700	μA
Output Leakage Current ($+V_{in} \geq 1.0\text{ Vdc}$, $-V_{in} = 0$, $V_O = 5.0\text{ Vdc}$) ($T_A = T_{low}$ to T_{high}) (Note 1)	I_{OL}	-	0.1 0.1	1.0 1.0	μA
Large-Signal Response	-	-	300	-	ns
Response Time (Note 3) ($V_{RL} = 5.0\text{ Vdc}$, $R_L = 5.1\text{ k}\Omega$)	-	-	1.3	-	μs

- NOTES:** 1. $T_{low} = 0^\circ\text{C}$, $T_{high} = +70^\circ\text{C}$
 2. $V_O \cong 1.4\text{ V}$, $R_S = 0\ \Omega$ with V_{CC} from 5.0 Vdc to 30 Vdc, and over the input common mode range 0 to $V_{CC} - 1.7\text{ V}$.
 3. The response time specified is for a 100 mV input step with 5.0 mV overdrive. For larger signals 300 ns is typical.

Representative Schematic Diagram
(1/2 of Circuit Shown)

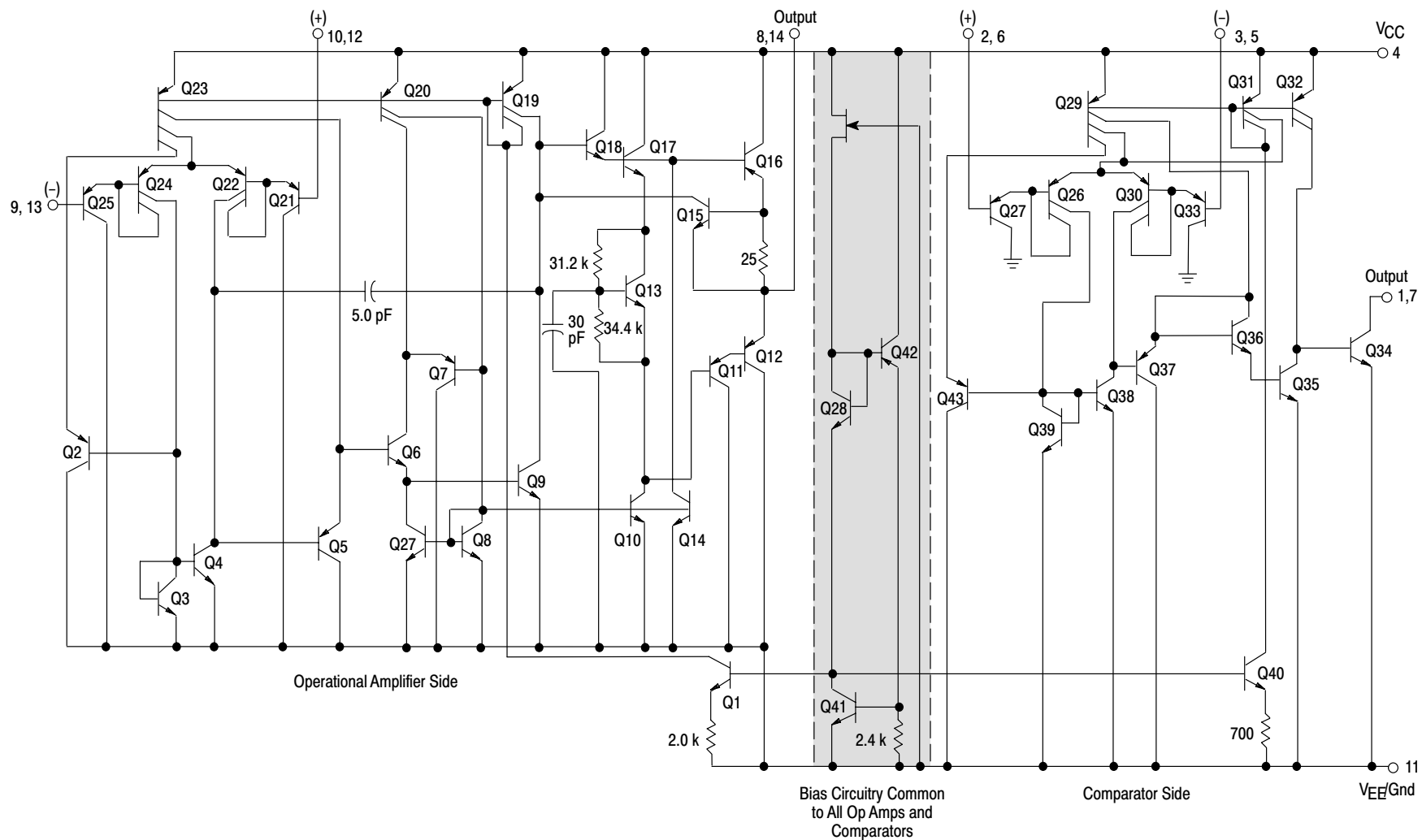

MC3405

MC3405

OPERATIONAL AMPLIFIER SECTION

Figure 1. Sine Wave Response

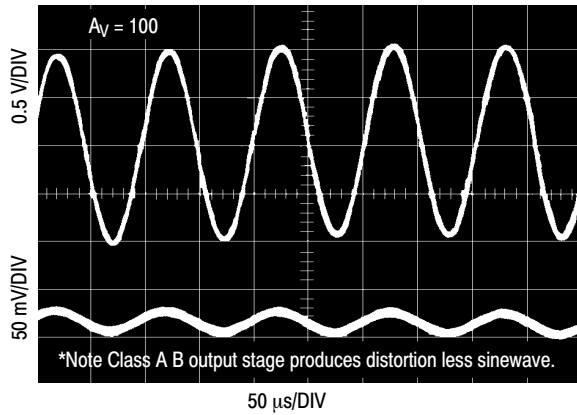

Figure 2. Open Loop Frequency Response

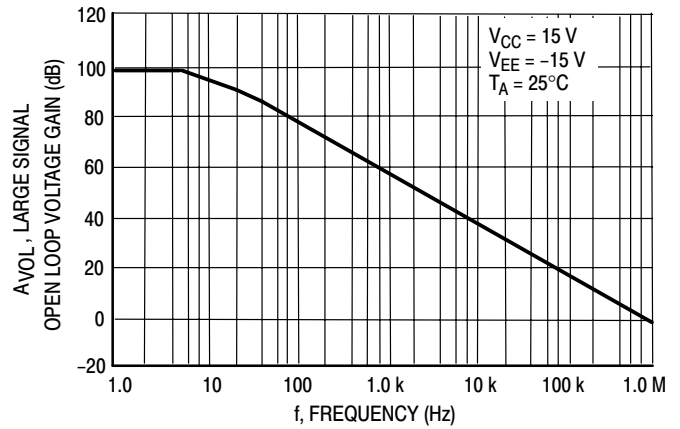

Figure 3. Power Bandwidth

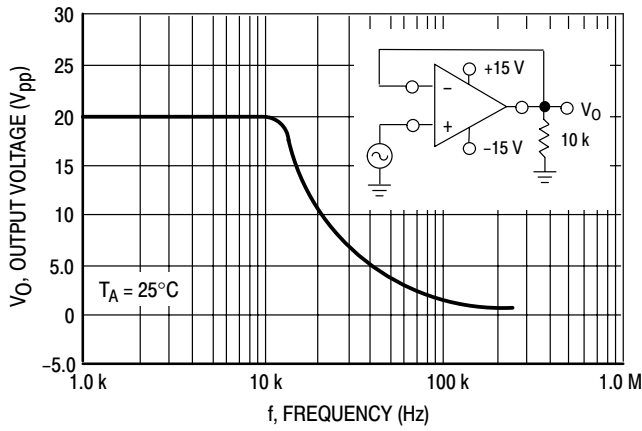

Figure 4. Output Swing versus Supply Voltage

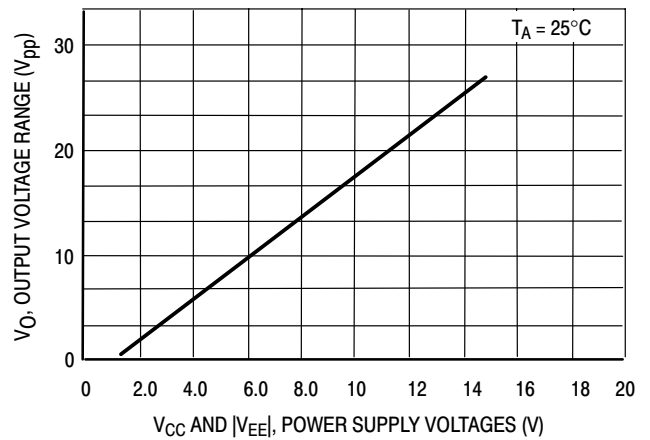

Figure 5. Input Bias Current versus Temperature

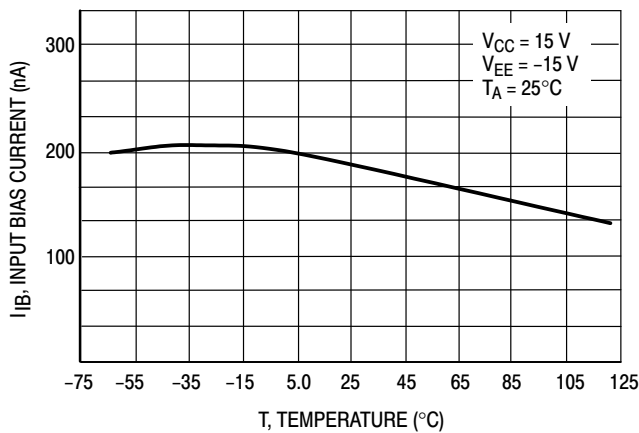
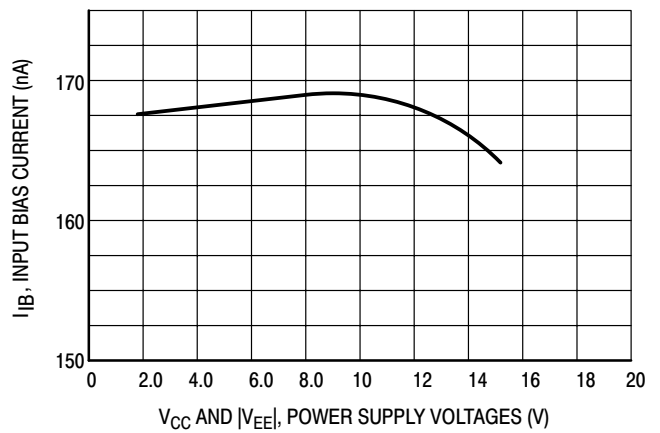

Figure 6. Input Bias Current versus Supply Voltage



MC3405

Figure 12. Window Comparator

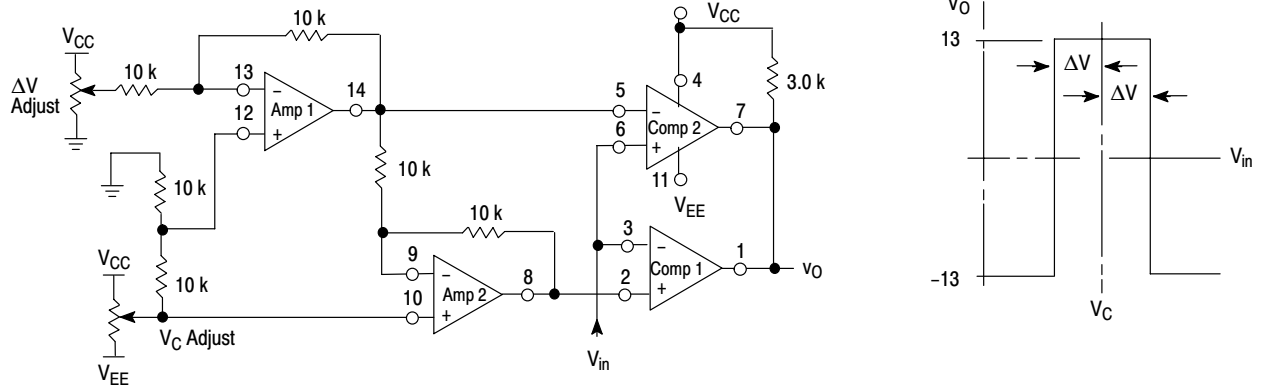

Figure 13. Squelch Circuit for AM or FM

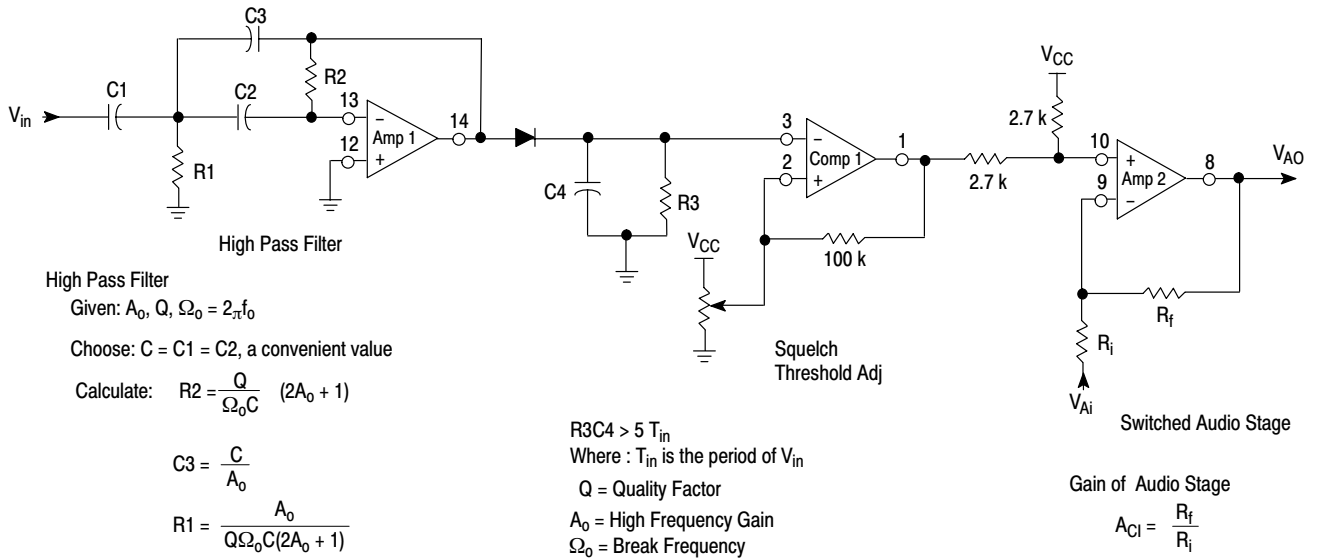

Figure 14. High/Low Limit Alarm

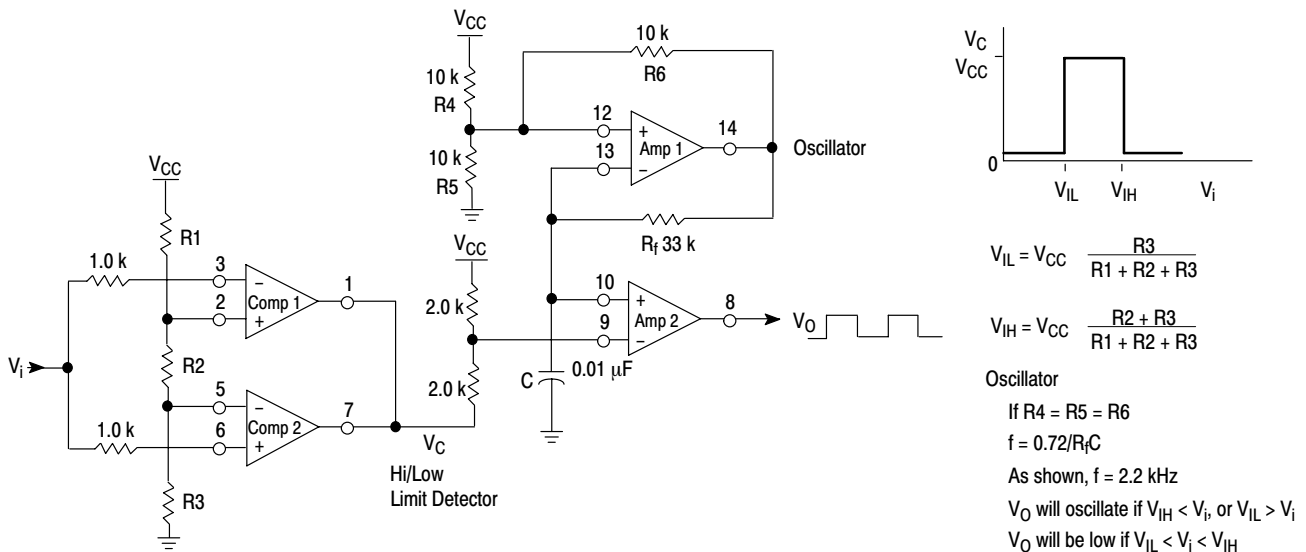

Figure 15. Zero Crossing Detector with Temperature Sensor

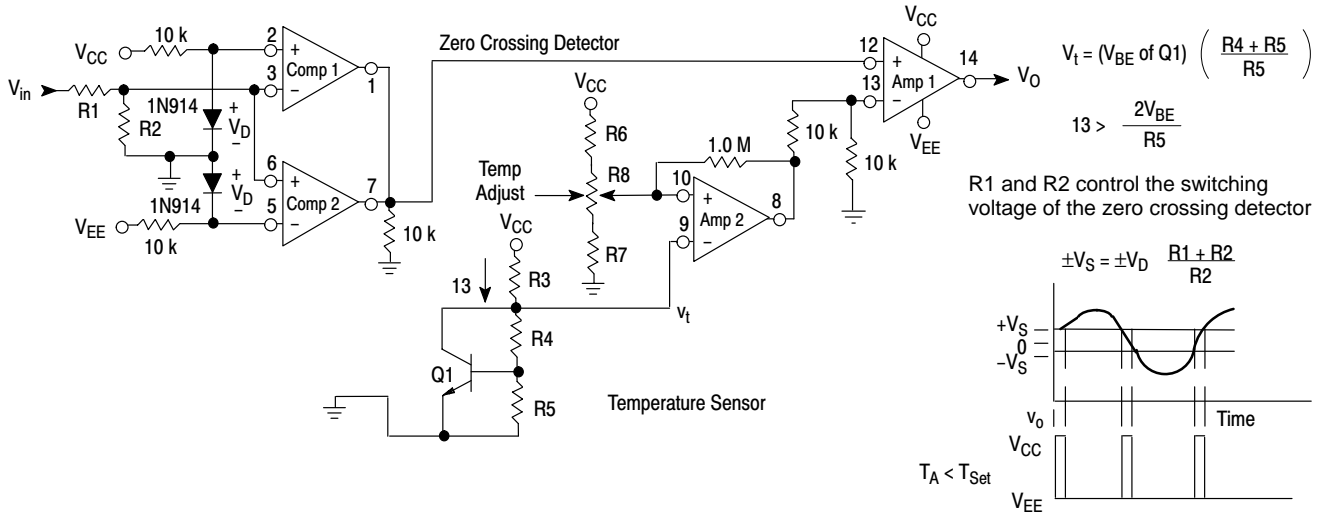
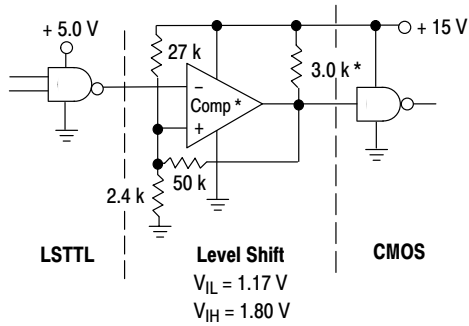
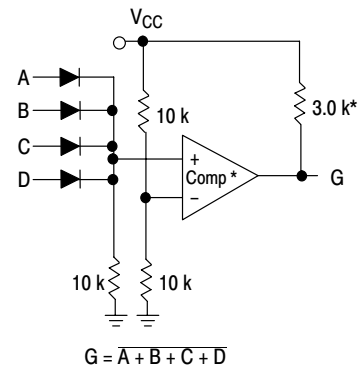

Figure 16. LSTTL to CMOS Interface with Hysteresis



*The same configuration may be used with an op amp if the 3.0 k resistor is removed.

Figure 17. NOR Gate



*The same configuration may be used with an op amp if the 3.0 k resistor is removed.

MC3405

PACKAGE DIMENSIONS

P SUFFIX PLASTIC PACKAGE CASE 646-06 ISSUE M

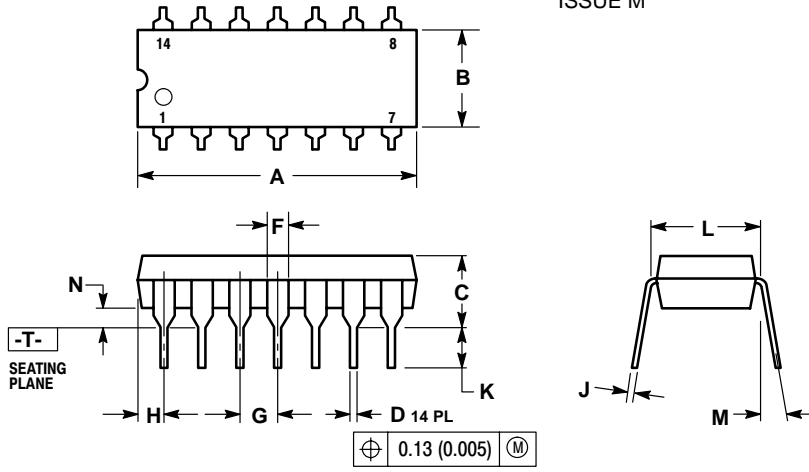

NOTES:

1. DIMENSIONING AND TOLERANCING PER ANSI Y14.5M, 1982.
2. CONTROLLING DIMENSION: INCH.
3. DIMENSION L TO CENTER OF LEADS WHEN FORMED PARALLEL.
4. DIMENSION B DOES NOT INCLUDE MOLD FLASH.
5. ROUNDED CORNERS OPTIONAL.

D SUFFIX (SO-14) PLASTIC PACKAGE CASE 751A-03 ISSUE F

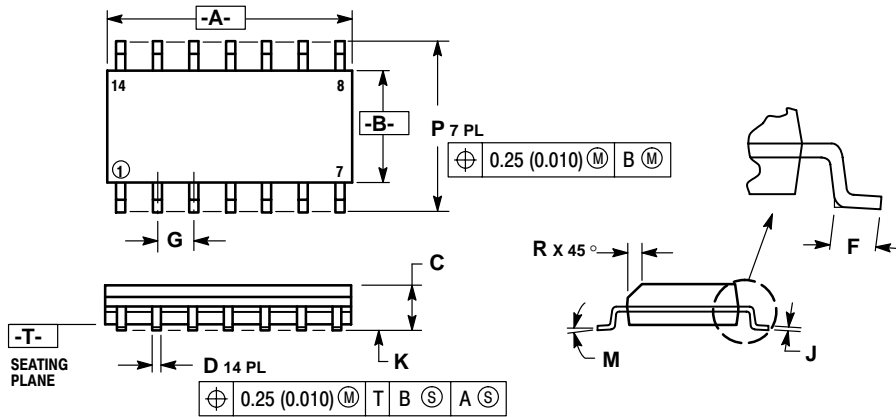

NOTES:

1. DIMENSIONING AND TOLERANCING PER ANSI Y14.5M, 1982.
2. CONTROLLING DIMENSION: MILLIMETER.
3. DIMENSIONS A AND B DO NOT INCLUDE MOLD PROTRUSION.
4. MAXIMUM MOLD PROTRUSION 0.15 (0.006) PER SIDE.
5. DIMENSION D DOES NOT INCLUDE DAMBAR PROTRUSION. ALLOWABLE DAMBAR PROTRUSION SHALL BE 0.127 (0.005) TOTAL IN EXCESS OF THE D DIMENSION AT MAXIMUM MATERIAL CONDITION.

DIM	MILLIMETERS		INCHES	
	MIN	MAX	MIN	MAX
A	8.55	8.75	0.337	0.344
B	3.80	4.00	0.150	0.157
C	1.35	1.75	0.054	0.068
D	0.35	0.49	0.014	0.019
F	0.40	1.25	0.016	0.049
G	1.27 BSC		0.050 BSC	
J	0.19	0.25	0.008	0.009
K	0.10	0.25	0.004	0.009
M	0°	7°	0°	7°
P	5.80	6.20	0.228	0.244
R	0.25	0.50	0.010	0.019

ON Semiconductor and  are registered trademarks of Semiconductor Components Industries, LLC (SCILLC). SCILLC reserves the right to make changes without further notice to any products herein. SCILLC makes no warranty, representation or guarantee regarding the suitability of its products for any particular purpose, nor does SCILLC assume any liability arising out of the application or use of any product or circuit, and specifically disclaims any and all liability, including without limitation special, consequential or incidental damages. "Typical" parameters which may be provided in SCILLC data sheets and/or specifications can and do vary in different applications and actual performance may vary over time. All operating parameters, including "Typicals" must be validated for each customer application by customer's technical experts. SCILLC does not convey any license under its patent rights nor the rights of others. SCILLC products are not designed, intended, or authorized for use as components in systems intended for surgical implant into the body, or other applications intended to support or sustain life, or for any other application in which the failure of the SCILLC product could create a situation where personal injury or death may occur. Should Buyer purchase or use SCILLC products for any such unintended or unauthorized application, Buyer shall indemnify and hold SCILLC and its officers, employees, subsidiaries, affiliates, and distributors harmless against all claims, costs, damages, and expenses, and reasonable attorney fees arising out of, directly or indirectly, any claim of personal injury or death associated with such unintended or unauthorized use, even if such claim alleges that SCILLC was negligent regarding the design or manufacture of the part. SCILLC is an Equal Opportunity/Affirmative Action Employer.

PUBLICATION ORDERING INFORMATION

Literature Fulfillment:

Literature Distribution Center for ON Semiconductor
P.O. Box 5163, Denver, Colorado 80217 USA
Phone: 303-675-2175 or 800-344-3860 Toll Free USA/Canada
Fax: 303-675-2176 or 800-344-3867 Toll Free USA/Canada
Email: ONlit@hibbertco.com

N. American Technical Support: 800-282-9855 Toll Free USA/Canada

JAPAN: ON Semiconductor, Japan Customer Focus Center
2-9-1 Kamimeguro, Meguro-ku, Tokyo, Japan 153-0051
Phone: 81-3-5773-3850

ON Semiconductor Website: <http://onsemi.com>

For additional information, please contact your local Sales Representative.