

10 9 8 7 6 5 4 3 2 1

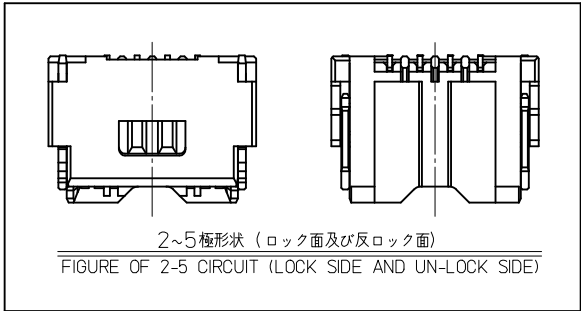

2~5極形状 (ロック面及び反ロック面)  
FIGURE OF 2-5 CIRCUIT (LOCK SIDE AND UN-LOCK SIDE)

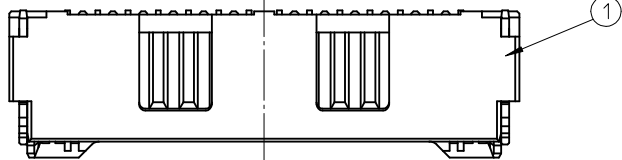
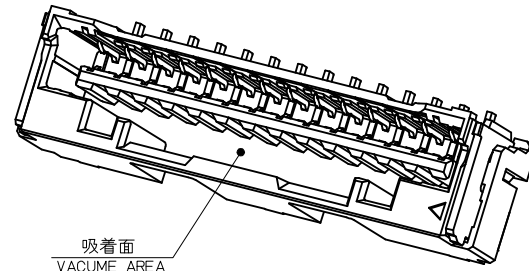

吸着面  
VACUME AREA

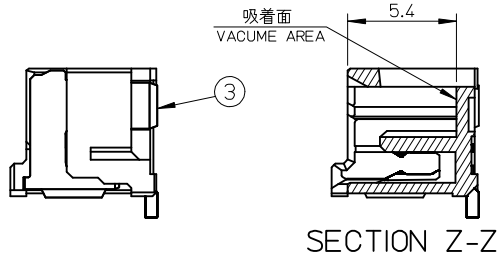
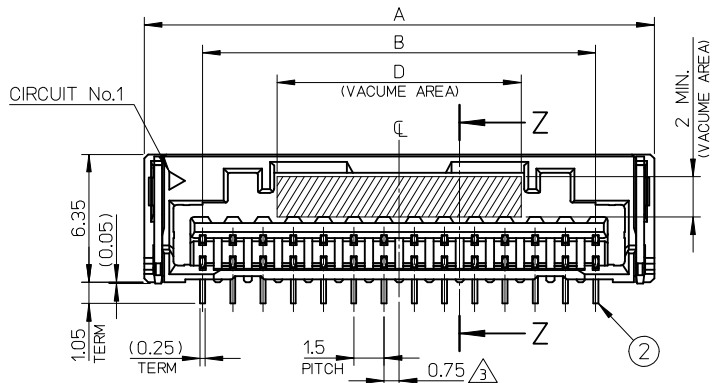

SECTION Z-Z

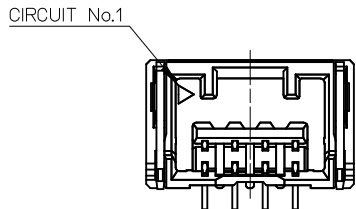
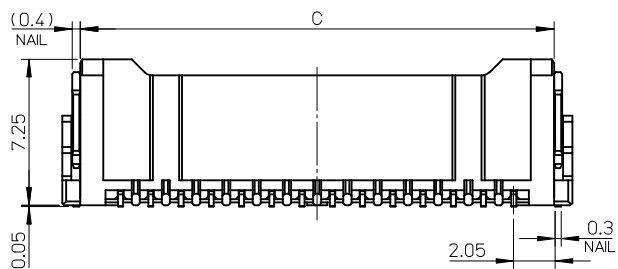

2~11極 CIRCUIT No.1  
CIRCUIT No.1 OF 2-11 CIRCUIT

12.1	25	21	26.8	502584-157*	15
12.1	23.5	19.5	25.3	-147*	14
12.1	22	18	23.8	-137*	13
12.1	20.5	16.5	22.3	-127*	12
12.1	19	15	20.8	-117*	11
10.1	17.5	13.5	19.3	-107*	10
10.1	16	12	17.8	-097*	9
8.6	14.5	10.5	16.3	-087*	8
7.1	13	9	14.8	-077*	7
6.2	11.5	7.5	13.3	-067*	6
3.2	10	6	11.8	-057*	5
2.9	8.5	4.5	10.3	-047*	4
2.15	7	3	8.8	-037*	3
2	5.5	1.5	7.3	502584-027*	2
D	C	B	A	EMBOSSD TAFE PACKAGE ORDER No.	CIRCUIT No.

No.	部品 PART	材料 MATERIAL
①	ハウジング HOUSING	耐熱性樹脂 UL94V-0 HEATPROOF RESIN UL94V-0
②	ターミナル TERMINAL	銅合金 COPPER ALLOY
		錫めっき: 1.0 micro-meter MIN. TIN (TAIL AREA)  ニッケルめっき(下地): 1.0 micro-meter MIN. NICKEL (UNDER PLATING)
③	ネイル NAIL	銅合金 COPPER ALLOY
		錫めっき: 1.0 micro-meter MIN. TIN  ニッケルめっき(下地): 1.0 micro-meter MIN. NICKEL (UNDER PLATING)

REVISED EC NO: J2010-0037 DRWN: ITO 2009/07/06 CHKD: K. ASAKAWA 2009/07/07 APPR: NUK ITA 2009/07/08	DESCRIPTION	GENERAL TOLERANCES (UNLESS SPECIFIED)		DIMENSION STYLE MM ONLY		SCALE 4:1	DESIGN UNITS METRIC		THIRD ANGLE PROJECTION		
		10 UNDER	±0.2	DRAWN BY N. ITO	DATE '07/07/09	TITLE 1.5MM W/B CONN. S/T REC. ASS'Y					
		10 OVER 30 UNDER	±0.25	CHECKED BY K. ASAKAWA	DATE '07/07/10	MOLEX INCORPORATED					
		30 OVER	±0.3	APPROVED BY Y. ITO	DATE '07/07/10						
REV		ANGULAR ±3 °	DRAFT WHERE APPLICABLE MUST REMAIN WITHIN DIMENSIONS		SEE CHART						
THIS DRAWING CONTAINS INFORMATION THAT IS PROPRIETARY TO MOLEX INCORPORATED AND SHOULD NOT BE USED WITHOUT WRITTEN PERMISSION											

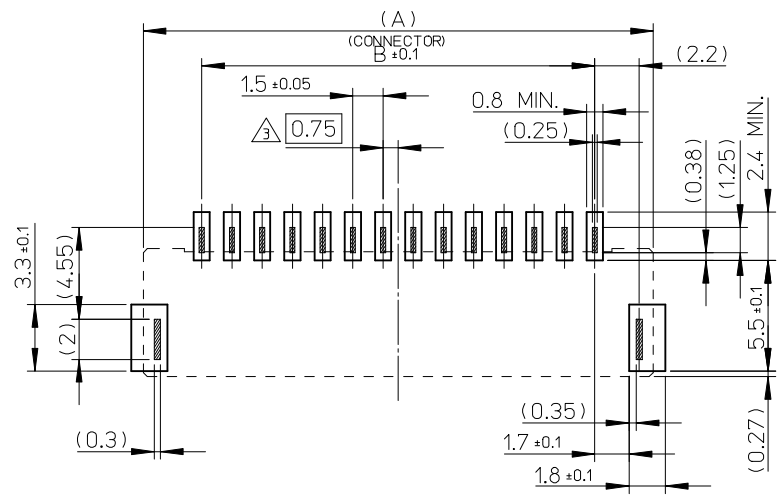

基板パターンレイアウト (参考)  
RECOMMENDED P.C.B PATTERN LAYOUT (REF.)

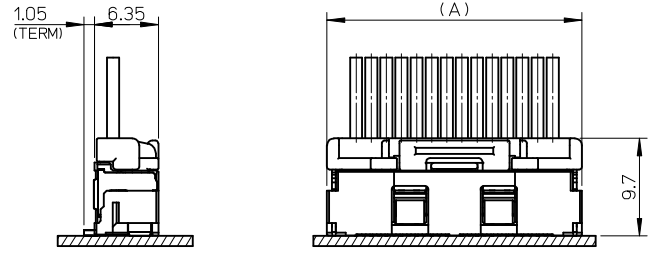

嵌合図  
MATED CONNECTORES

NOTES

1. 嵌合相手: 502578 シリーズ  
MATE WITH: 502578 SERIES.
2. 端子テール部及びネイルの平坦度: 0.1 MAX.  
TAIL AND NAIL COPLANARITY TO BE 0.1 MAX.
- △ 3. 極数/2=偶数に適用  
APPLY FOR CIRCUIT SIZE / 2 = EVEN
4. 端子テール部及びネイルに錫めっきを使用している為、  
外観に摺動痕が付く場合があります。  
THE WOUND OF FRICTION MIGHT ADHERE TO EXTERNALS  
BECAUSE THE TIN PLATING IS USED FOR THE TAIL AND NAIL.
5. 製品番号  
MATERIAL No.  
502584-\*\*\*

極数  
CIRCUIT SIZE

色  
COLOR

No.	COLOR	CIRCUIT
70	ベージュ BEIGE	2~15
71	黒 BLACK	
72	赤 RED	
73	黄 YELLOW	
74	青 BLUE	
75	桃 PINK	
76	緑 GREEN	
77	茶 BROWN	
78	橙 ORANGE	
79	紫 VIOLET	

6. 本製品のプラスチック部に黒点・白点等が確認される場合や  
色合いが異なる場合がありますが、製品性能に影響はありません。  
THERE IS NO INFLUENCE IN THE PRODUCT  
PERFORMANCE THOUGH THE BLACK AND WHITE SPOT ETC.  
MIGHT BE CONFIRMED TO THE PLASTIC PART OF  
THIS PRODUCT AND THE SHADE MIGHT BE DIFFERENT.
7. ELV 及び RoHS 適合品  
ELV AND RoHS COMPLIANT

△ 8. ORDER No. AND CONNECTOR SERIES No.

REVISED EC NO: J2010-0037 DRWN: ITO CHKD: K. ASAKAWA APPR: NUKITA	DESCRIPTION REV	GENERAL TOLERANCES (UNLESS SPECIFIED)		DIMENSION STYLE MM ONLY		SCALE 4:1	DESIGN UNITS METRIC	THIRD ANGLE PROJECTION		
		10 UNDER	±0.2	DRAWN BY N. ITO	DATE '07/07/09	TITLE 1.5MM W/B CONN. S/T REC. ASS'Y				
		10 OVER 30 UNDER	±0.25	CHECKED BY K. ASAKAWA	DATE '07/07/10	APPROVED BY Y. ITO				
		30 OVER	±0.3	APPROVED BY Y. ITO		DATE '07/07/10	MOLEX INCORPORATED			
ANGULAR ±3 °		DRAFT WHERE APPLICABLE MUST REMAIN WITHIN DIMENSIONS		MATERIAL NO. SEE CHART		DOCUMENT NO. SD-502584-001		SHEET NO. 2 OF 3		
SIZE A3		THIS DRAWING CONTAINS INFORMATION THAT IS PROPRIETARY TO MOLEX INCORPORATED AND SHOULD NOT BE USED WITHOUT WRITTEN PERMISSION								

△ ORDER No. AND CONNECTOR SERIES No.

HSG COLOR : BLUE		HSG COLOR : YELLOW		HSG COLOR : RED		HSG COLOR : BLACK		HSG COLOR : BEIGE		
502584-1574	502584-***74	502584-1573	502584-***73	502584-1572	502584-***72	502584-1571	502584-***71	502584-1570	502584-***70	15
502584-1474		502584-1473		502584-1472		502584-1471		502584-1470		14
502584-1374		502584-1373		502584-1372		502584-1371		502584-1370		13
502584-1274		502584-1273		502584-1272		502584-1271		502584-1270		12
502584-1174		502584-1173		502584-1172		502584-1171		502584-1170		11
502584-1074		502584-1073		502584-1072		502584-1071		502584-1070		10
502584-0974		502584-0973		502584-0972		502584-0971		502584-0970		9
502584-0874		502584-0873		502584-0872		502584-0871		502584-0870		8
502584-0774		502584-0773		502584-0772		502584-0771		502584-0770		7
502584-0674		502584-0673		502584-0672		502584-0671		502584-0670		6
502584-0574		502584-0573		502584-0572		502584-0571		502584-0570		5
502584-0474		502584-0473		502584-0472		502584-0471		502584-0470		4
502584-0374		502584-0373		502584-0372		502584-0371		502584-0370		3
502584-0274		502584-0273		502584-0272		502584-0271		502584-0270		2
EMBOSSSED TAPE PACKAGE オーダー番号ORDER No.	コネクタシリーズ CONNECTOR SERIES	EMBOSSSED TAPE PACKAGE オーダー番号ORDER No.	コネクタシリーズ CONNECTOR SERIES	EMBOSSSED TAPE PACKAGE オーダー番号ORDER No.	コネクタシリーズ CONNECTOR SERIES	EMBOSSSED TAPE PACKAGE オーダー番号ORDER No.	コネクタシリーズ CONNECTOR SERIES	EMBOSSSED TAPE PACKAGE オーダー番号ORDER No.	コネクタシリーズ CONNECTOR SERIES	極数 (KT. NO.)

HSG COLOR : VIOLET		HSG COLOR : ORANGE		HSG COLOR : BROWN		HSG COLOR : GREEN		HSG COLOR : PINK		
502584-1579	502584-***79	502584-1578	502584-***78	502584-1577	502584-***77	502584-1576	502584-***76	502584-1575	502584-***75	15
502584-1479		502584-1478		502584-1477		502584-1476		502584-1475		14
502584-1379		502584-1378		502584-1377		502584-1376		502584-1375		13
502584-1279		502584-1278		502584-1277		502584-1276		502584-1275		12
502584-1179		502584-1178		502584-1177		502584-1176		502584-1175		11
502584-1079		502584-1078		502584-1077		502584-1076		502584-1075		10
502584-0979		502584-0978		502584-0977		502584-0976		502584-0975		9
502584-0879		502584-0878		502584-0877		502584-0876		502584-0875		8
502584-0779		502584-0778		502584-0777		502584-0776		502584-0775		7
502584-0679		502584-0678		502584-0677		502584-0676		502584-0675		6
502584-0579		502584-0578		502584-0577		502584-0576		502584-0575		5
502584-0479		502584-0478		502584-0477		502584-0476		502584-0475		4
502584-0379		502584-0378		502584-0377		502584-0376		502584-0375		3
502584-0279		502584-0278		502584-0277		502584-0276		502584-0275		2
EMBOSSSED TAPE PACKAGE オーダー番号ORDER No.	コネクタシリーズ CONNECTOR SERIES	EMBOSSSED TAPE PACKAGE オーダー番号ORDER No.	コネクタシリーズ CONNECTOR SERIES	EMBOSSSED TAPE PACKAGE オーダー番号ORDER No.	コネクタシリーズ CONNECTOR SERIES	EMBOSSSED TAPE PACKAGE オーダー番号ORDER No.	コネクタシリーズ CONNECTOR SERIES	EMBOSSSED TAPE PACKAGE オーダー番号ORDER No.	コネクタシリーズ CONNECTOR SERIES	極数 (KT. NO.)

REVISED EC NO: J2010-0037 DRW: NITO 2009/07/06 CHK: K. ASAKAWA 2009/07/07 APPR: NUKITA 2009/07/08	GENERAL TOLERANCES (UNLESS SPECIFIED)		DIMENSION STYLE <b>MM ONLY</b>		SCALE <b>4:1</b>	DESIGN UNITS <b>METRIC</b>		THIRD ANGLE PROJECTION	
	10 UNDER	±0.2	DRAWN BY N. ITO	DATE '07/07/09	TITLE <b>1.5MM W/B CONN. S/T REC. ASS'Y</b>				
	10 OVER 30 UNDER	±0.25	CHECKED BY K. ASAKAWA	DATE '07/07/10	 <b>MOLEX INCORPORATED</b>				
	30 OVER	±0.3	APPROVED BY Y. ITO	DATE '07/07/10					
ANGULAR ±3 °		DRAFT WHERE APPLICABLE MUST REMAIN WITHIN DIMENSIONS		MATERIAL NO. <b>SEE CHART</b>		DOCUMENT NO. <b>SD-502584-001</b>		SHEET NO. <b>3 OF 3</b>	
SIZE <b>A3</b> THIS DRAWING CONTAINS INFORMATION THAT IS PROPRIETARY TO MOLEX INCORPORATED AND SHOULD NOT BE USED WITHOUT WRITTEN PERMISSION									

引き出し方向  
PULL OUT DIRECTION

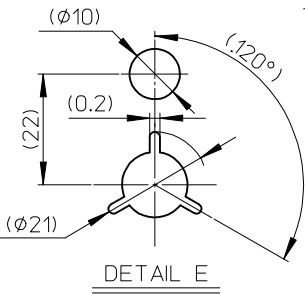
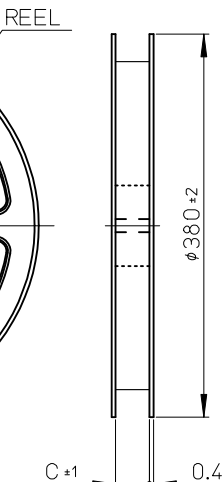
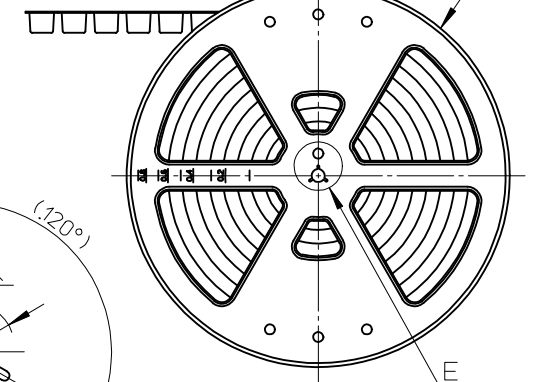

引き出し方向  
PULL OUT DIRECTION

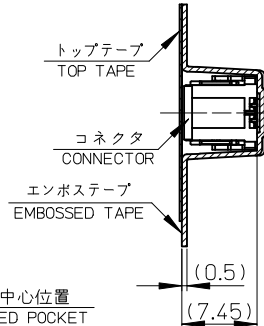
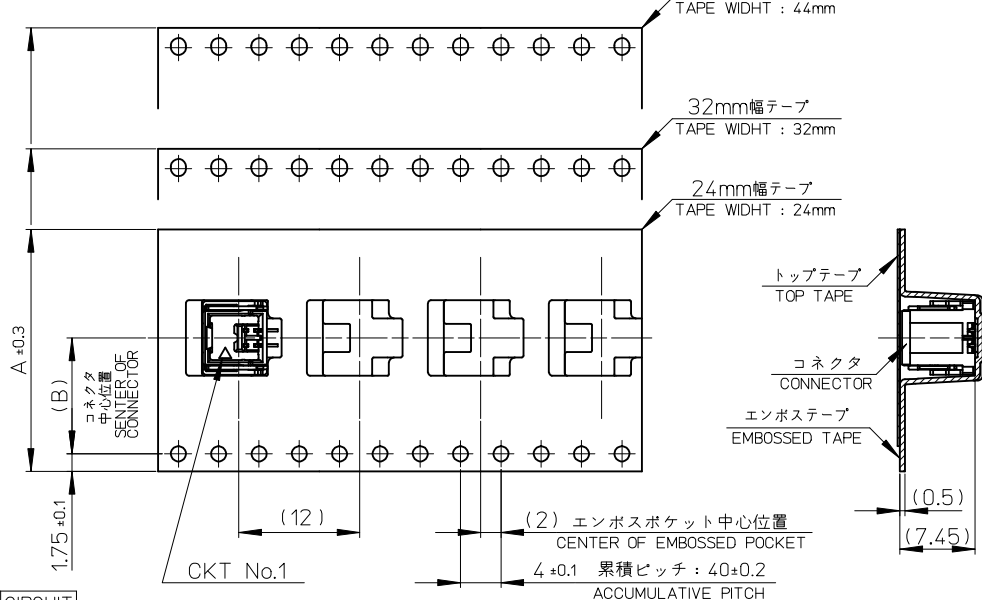

NOTES

- 製品詳細寸法については、SD-502584-001を参照下さい。  
PLEASE REFER TO SD-502584-001 FOR THE DETAILED DIMENSION OF THE CONNECTOR.
- 梱包数量：900個  
NUMBER OF CONNECTORS：900 PIECES/REEL.
- リードテープ長さ  
LEAD TAPE LENGTH

トップテープ接着部(空エンボス)  
20 PIECES MIN.  
TOP TAPE BONDED PART(EMPTY)

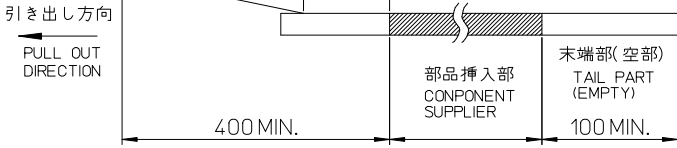

No.	COLOR	CIRCUIT
70	ベージュ BEIGE	2~15
71	黒 BLACK	
72	赤 RED	
73	黄 YELLOW	
74	青 BLUE	
75	桃 PINK	
76	緑 GREEN	
77	茶 BROWN	
78	橙 ORANGE	
79	紫 VIOLET	

45.5	20.2	44	502584-157*	15
45.5	20.2	44	-147*	14
45.5	20.2	44	-137*	13
45.5	20.2	44	-127*	12
45.5	20.2	44	-117*	11
45.5	20.2	44	-107*	10
33.5	14.2	32	-097*	9
33.5	14.2	32	-087*	8
33.5	14.2	32	-077*	7
33.5	14.2	32	-067*	6
25.5	11.5	24	-057*	5
25.5	11.5	24	-047*	4
25.5	11.5	24	-037*	3
25.5	11.5	24	502584-027*	2

C B エンボステープ幅A 製品番号 極数  
WIDTH OF TAPE MATERIAL NO. (KT. NO.)

- 材料  
MATERIAL  
キャリアテープ：ポリスチレン  
CARRIER TAPE：POLYSTYRENE  
トップテープ：ポリエステル、ポリエチレン、ポリエチレンテレフタレート  
TOP TAPE：POLYESTER, POLYETHYLENE, POLYETHYLENE TEREPHTHALATE  
リール：ポリスチレン <リサイクル材を含む>  
REEL：POLYSTYRENE <RECYCLE MATERIAL CONTAINED>

- ELV 及び RoHS 適合品  
ELV AND RoHS COMPLIANT

△ 製品番号  
MATERIAL NO.  
502584-\*\*\*\*  
↑ 極数  
↑ 色  
CIRCUIT SIZE COLOR

- ORDER No. AND CONNECTOR SERIES No.
- 本製品は乾燥剤入り、ハイバリア梱包仕様である。  
THIS PRODUCT IS HIGH BARRIER PACKAGE WITH DESICCANT.

REVISED EC NO: J2010-0624 DRWN: NITO 2009/10/07 CHKD: KASAKAWA 2009/10/07 APPR: NUKITA 2009/10/08	DESCRIPTION	GENERAL TOLERANCES (UNLESS SPECIFIED)		DIMENSION STYLE MM ONLY		SCALE ---	DESIGN UNITS METRIC		THIRD ANGLE PROJECTION	
		10 UNDER	±0.2	DRAWN BY NITO	DATE 2007/07/17	TITLE EMBOSSSED TAPE PACKAGE FOR 502584		MOLEX MOLEX INCORPORATED		SHEET NO. 1 OF 2
10 OVER 30 UNDER	±0.25	CHECKED BY KASAKAWA	DATE 2007/07/17	MATERIAL NO. SEE TABLE		DOCUMENT NO. SD-502584-002		INCORPORATED AND SHOULD NOT BE USED WITHOUT WRITTEN PERMISSION		
30 OVER	±0.3	APPROVED BY YOITO	DATE 2007/07/17	SIZE A3		THIS DRAWING CONTAINS INFORMATION THAT IS PROPRIETARY TO MOLEX INCORPORATED AND SHOULD NOT BE USED WITHOUT WRITTEN PERMISSION				
ANGULAR ±1 °		DRAFT WHERE APPLICABLE MUST REMAIN WITHIN DIMENSIONS								

△ ORDER No. AND CONNECTOR SERIES No.

HSG COLOR : BLUE		HSG COLOR : YELLOW		HSG COLOR : RED		HSG COLOR : BLACK		HSG COLOR : BEIGE		
502584-***74	502584-1574	502584-***73	502584-1573	502584-***72	502584-1572	502584-***71	502584-1571	502584-***70	502584-1570	15
	502584-1474		502584-1473		502584-1472		502584-1471		502584-1470	14
	502584-1374		502584-1373		502584-1372		502584-1371		502584-1370	13
	502584-1274		502584-1273		502584-1272		502584-1271		502584-1270	12
	502584-1174		502584-1173		502584-1172		502584-1171		502584-1170	11
	502584-1074		502584-1073		502584-1072		502584-1071		502584-1070	10
	502584-0974		502584-0973		502584-0972		502584-0971		502584-0970	9
	502584-0874		502584-0873		502584-0872		502584-0871		502584-0870	8
	502584-0774		502584-0773		502584-0772		502584-0771		502584-0770	7
	502584-0674		502584-0673		502584-0672		502584-0671		502584-0670	6
	502584-0574		502584-0573		502584-0572		502584-0571		502584-0570	5
	502584-0474		502584-0473		502584-0472		502584-0471		502584-0470	4
	502584-0374		502584-0373		502584-0372		502584-0371		502584-0370	3
	502584-0274		502584-0273		502584-0272		502584-0271		502584-0270	2
コネクタ シリーズ CONNECTOR SERIES	製品番号 MATERIAL NO.	コネクタ シリーズ CONNECTOR SERIES	製品番号 MATERIAL NO.	コネクタ シリーズ CONNECTOR SERIES	製品番号 MATERIAL NO.	コネクタ シリーズ CONNECTOR SERIES	製品番号 MATERIAL NO.	コネクタ シリーズ CONNECTOR SERIES	製品番号 MATERIAL NO.	極数 (KT. NO.)

HSG COLOR : VIOLET		HSG COLOR : ORANGE		HSG COLOR : BROWN		HSG COLOR : GREEN		HSG COLOR : PINK		
502584-***79	502584-1579	502584-***78	502584-1578	502584-***77	502584-1577	502584-***76	502584-1576	502584-***75	502584-1575	15
	502584-1479		502584-1478		502584-1477		502584-1476		502584-1475	14
	502584-1379		502584-1378		502584-1377		502584-1376		502584-1375	13
	502584-1279		502584-1278		502584-1277		502584-1276		502584-1275	12
	502584-1179		502584-1178		502584-1177		502584-1176		502584-1175	11
	502584-1079		502584-1078		502584-1077		502584-1076		502584-1075	10
	502584-0979		502584-0978		502584-0977		502584-0976		502584-0975	9
	502584-0879		502584-0878		502584-0877		502584-0876		502584-0875	8
	502584-0779		502584-0778		502584-0777		502584-0776		502584-0775	7
	502584-0679		502584-0678		502584-0677		502584-0676		502584-0675	6
	502584-0579		502584-0578		502584-0577		502584-0576		502584-0575	5
	502584-0479		502584-0478		502584-0477		502584-0476		502584-0475	4
	502584-0379		502584-0378		502584-0377		502584-0376		502584-0375	3
	502584-0279		502584-0278		502584-0277		502584-0276		502584-0275	2
コネクタ シリーズ CONNECTOR SERIES	製品番号 MATERIAL NO.	コネクタ シリーズ CONNECTOR SERIES	製品番号 MATERIAL NO.	コネクタ シリーズ CONNECTOR SERIES	製品番号 MATERIAL NO.	コネクタ シリーズ CONNECTOR SERIES	製品番号 MATERIAL NO.	コネクタ シリーズ CONNECTOR SERIES	製品番号 MATERIAL NO.	極数 (KT. NO.)

REVISED EC NO: J2010-0624 2009/10/07 DRWN: NITO 2009/10/07 CHKD: KASAKAWA 2009/10/07 APPR: NUKITA 2009/10/08 DESCRIPTION REV	GENERAL TOLERANCES (UNLESS SPECIFIED)		DIMENSION STYLE MM ONLY		SCALE ---	DESIGN UNITS METRIC	THIRD ANGLE PROJECTION		
	10 UNDER	±0.2	DRAWN BY NITO	DATE 2007/07/17	TITLE EMBOSSSED TAPE PACKAGE FOR 502584				
	10 OVER 30 UNDER	±0.25	CHECKED BY KASAKAWA	DATE 2007/07/17	APPROVED BY YOITO				
	30 OVER	±0.3	DATE 2007/07/17	MATERIAL NO.		DOCUMENT NO.		SHEET NO.	
	ANGULAR ±1 ° DRAFT WHERE APPLICABLE MUST REMAIN WITHIN DIMENSIONS		SIZE A3		SEE TABLE		SD-502584-002		2 OF 2