

PRIORITY

No. T957F21

SPECIFICATION

HIGH-FREQUENCY MULTI-LAYER
CHIP INDUCTOR

HK2125 TYPE SERIES

TAIYO YUDEN CO., LTD.

DATE: 27. Aug. 1997

TAIYS00004

DELIVERY SPECIFICATION

1. Scope

This Specification applies to high-frequency multi-layer chip inductors Taiyo Yuden Co., Ltd. will deliver.

2. The ordering codes of the products specified hereof shall be as shown in page 5.

3. Appearance, Shape, Dimensions and materials.

3-1 Appearance : To be free from any defects which will hinder practical use.

3-2 Shape and Dimensions : Conforms to Table 1 shown in page 2.

Materials : Conforms to Table 2 shown in page 2.

4. Electrical Characteristics

Conforms to page 5. The measuring conditions for the characteristics shall conform to the requirements specified in pages 3 to 4.

5. Mechanical Characteristics

Conforms to Item 5.1 to Item 5.3 of page 6.

6. Tests

Conforms to Item 5.4 to Item 5.12 of pages 6 to 9.

7. Packaging and Marking

The products shall be packaged to be free from water absorption and damages and the following information shall be marked on each of packages.

7-1 Ordering codes or names shall conform those shown in page 5.

7-2 Lot No.

7-3 Manufacturer.

8. Packaging and Modes

Taping specification shall conform to the requirements described in page 10 to 11.

9. Testing Conditions

Unless otherwise specified, the temperature shall be 5 to 35 °C and the humidity shall be 45 to 85 %. If there is a question as to these testing conditions, the temperature shall be 20 ± 2 °C and the humidity shall be 60 to 70 %.

[1] Shape, Dimensions and Materials

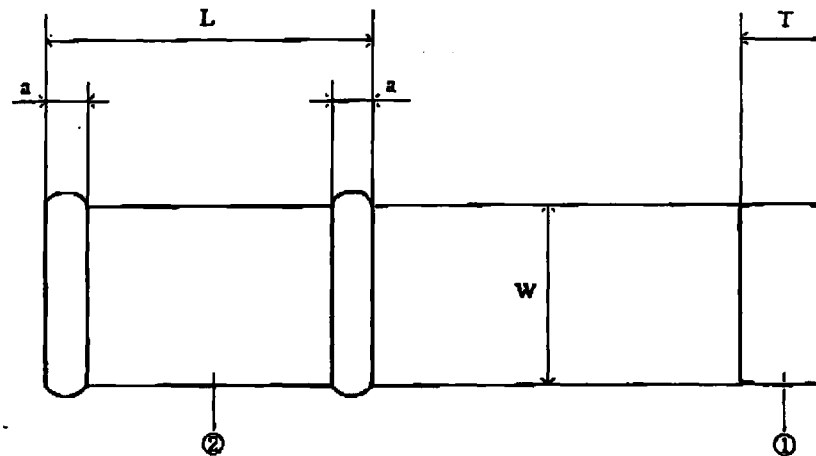

Table 1

Type	Dimensions and Tolerance (mm)			
	Length L	Width W	Thickness T	Electrode Width a
HK2125	$2.0^{+0.3}_{-0.1}$	1.25 ± 0.2	0.85 ± 0.2	0.5 ± 0.3
	"	"	$1.00^{+0.2}_{-0.3}$	"

Table 2

Component		Material and treatment
①	Electrode	Ag (Ni, and solder by electroplating)
②	Ceramic	dielectric glass ceramic

[2] Operating Temperature Range

-25 °C to +85 °C

[3] Electrical Characteristics Measuring Method

3-1 Inductance and Q values

Equipment to be used :

HP 4195A

Test fixtures :

HP 16092A

Measuring method :

A chip-inductor set in a position of stated height showing below figure.

The inductance value and Q value shall be read by the measuring

frequencies shown in Table 3.

Position of Chip Inductor

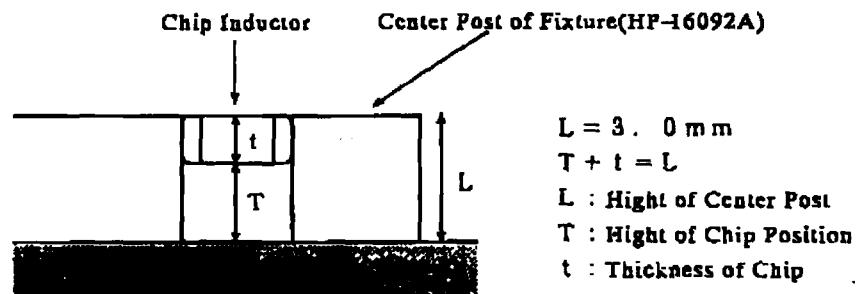

3-2 DC resistance

Circuits of Equipment and Instruments to be Used.

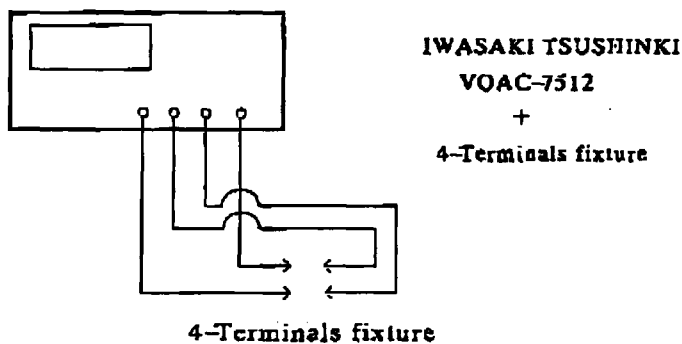

Measuring method :

A chip shall be set on 4-Terminals fixture.

The resistance value shall be read.

3-3 SRF (Self - resonant Frequency)

Equipment to be used :

HP 8753D

Measuring method :

S.R.F. shall be read from the impedance characteristics data measured by a network analyzer.

S.R.F. shall be the frequency indicated on this data where the difference between the inductive reactance and the capacitive reactance is zero.

3-4 IDC

Measuring circuit :

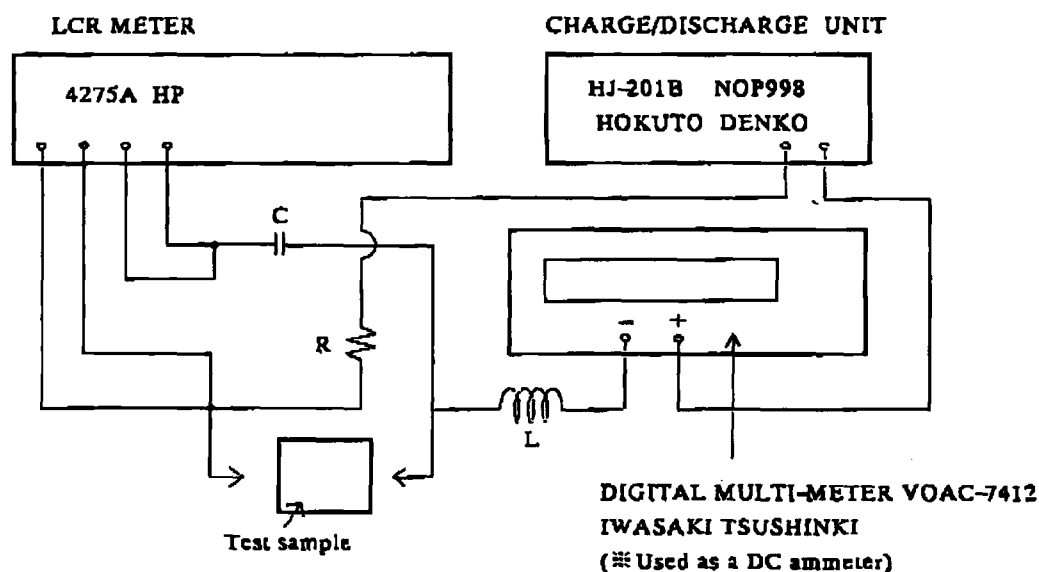

Measuring method :

Measuring frequency 10MHz

The initial L value shall be measured under the above condition. After the voltage of the DC power supply has been increased, the L(nH) value at respective currents at this time shall be "IDC".

Definition of IDC

The direct current When the L(nH) value is reduced 5% in comparison to the initial L(nH) value or temperature rise of 20 °C by application of direct current, whichever comes first.

[4] Electrical Characteristics

Table 3

Ordering Code	Thickness t(mm)	Inductance L(nH)	Tolerance	Q MIN	LQ Measuring Frequency (MHz)	Self-resonant Frequency SRF(MHz)	DC Resistance Rdc(Ω)	Allowable current IDC(mA)
HK 2125 1N5□-○	0.85±0.2	1.5	S	10	100	4000MIN	0.10MAX	300
HK 2125 1N8□-○	0.85±0.2	1.8	S	10	100	4000MIN	0.10MAX	300
HK 2125 2N2□-○	0.85±0.2	2.2	S	10	100	4000MIN	0.10MAX	300
HK 2125 2N7□-○	0.85±0.2	2.7	S	12	100	4000MIN	0.10MAX	300
HK 2125 3N3□-○	0.85±0.2	3.3	KorS	12	100	4000MIN	0.13MAX	300
HK 2125 3N9□-○	0.85±0.2	3.9	KorS	12	100	4000MIN	0.15MAX	300
HK 2125 4N7□-○	0.85±0.2	4.7	KorS	12	100	3500MIN	0.20MAX	300
HK 2125 5N6□-○	0.85±0.2	5.6	KorS	15	100	3200MIN	0.23MAX	300
HK 2125 6N8□-○	0.85±0.2	6.8	KorJ	15	100	2800MIN	0.25MAX	300
HK 2125 8N2□-○	0.85±0.2	8.2	KorJ	15	100	2400MIN	0.28MAX	300
HK 2125 10N□-○	0.85±0.2	10.0	KorJ	15	100	2100MIN	0.30MAX	300
HK 2125 12N□-○	0.85±0.2	12.0	KorJ	15	100	1900MIN	0.35MAX	300
HK 2125 15N□-○	0.85±0.2	15.0	KorJ	15	100	1600MIN	0.40MAX	300
HK 2125 18N□-○	0.85±0.2	18.0	KorJ	15	100	1500MIN	0.45MAX	300
HK 2125 22N□-○	0.85±0.2	22.0	KorJ	18	100	1400MIN	0.50MAX	300
HK 2125 27N□-○	0.85±0.2	27.0	KorJ	18	100	1300MIN	0.55MAX	300
HK 2125 33N□-○	0.85±0.2	33.0	KorJ	18	100	1200MIN	0.60MAX	300
HK 2125 39N□-○	0.85±0.2	39.0	KorJ	18	100	1000MIN	0.65MAX	300
HK 2125 47N□-○	1.00+0.2-0.3	47.0	KorJ	18	100	900MIN	0.70MAX	300
HK 2125 56N□-○	1.00+0.2-0.3	56.0	KorJ	18	100	800MIN	0.75MAX	300
HK 2125 68N□-○	1.00+0.2-0.3	68.0	KorJ	18	100	700MIN	0.80MAX	300
HK 2125 82N□-○	1.00+0.2-0.3	82.0	KorJ	18	100	600MIN	0.90MAX	300
HK 2125 R10□-○	1.00+0.2-0.3	100.0	KorJ	18	100	600MIN	0.90MAX	300
HK 2125 R12□-○	1.00+0.2-0.3	120.0	KorJ	13	50	500MIN	0.95MAX	300
HK 2125 R15□-○	1.00+0.2-0.3	150.0	KorJ	13	50	500MIN	1.00MAX	300
HK 2125 R18□-○	1.00+0.2-0.3	180.0	KorJ	13	50	400MIN	1.10MAX	300
HK 2125 R22□-○	1.00+0.2-0.3	220.0	KorJ	13	50	350MIN	1.20MAX	300
HK 2125 R27□-○	1.00+0.2-0.3	270.0	KorJ	12	50	300MIN	1.30MAX	300
HK 2125 R33□-○	1.00+0.2-0.3	330.0	KorJ	12	50	270MIN	1.40MAX	300
HK 2125 R39□-○	1.00+0.2-0.3	390.0	KorJ	10	50	250MIN	1.30MAX	300
HK 2125 R47□-○	1.00+0.2-0.3	470.0	KorJ	10	50	200MIN	1.50MAX	300

※ K=±10%, J=±5%, S=±0.3nH

□=FOR TOL K, J, OR S, ○=PACKING B(FOR BULK) AND T(FOR TAPING).

[5] Chip Inductor Reliability Test

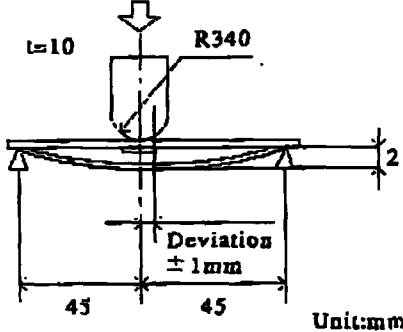
Order	Item	Specification	Testing Method
5. 1	Deflection test	To be free from mechanical damage.	<p>Solder a test sample to the printed circuit board shown in Attached Drawing 1 and apply a load in the arrow direction until an amount of deflection reaches 2 mm.</p>  <p style="text-align: right;">Unit:mm</p>
5. 2	Vibration test	To be free from mechanical damage. Inductance variation: Within $\pm 10\%$ Q variation: Within $\pm 20\%$	<p>The test sample shall be soldered to the jig shown in Fig 2.</p> <p>Testing conditions:</p> <p>Frequency range : 10~55Hz Overall amplitude : 1.5mm Sweeping method : 10~55~10Hz for 1 min. Each two hours in X,Y,Z direction : 6 hours in total</p>
5. 3	Falling test	Same as above	Fall a test sample spontaneously 10 times from a 1 meter high position onto a concrete floor.
5. 4	Humidity test	Same as above	<p>Keep a test sample in an atmosphere with a temperature of $60 \pm 2^\circ\text{C}$ for 500 ± 12 hours. (Humidity 90 to 95%) After the test, keep the test sample at a normal temperature with a normal humidity for 1 to 2 hours, then carry out measurement.</p>

[5] Chip Inductor Reliability Test

Order	Item	Specification	Testing Method
5. 5	Heat resistance test	To be free from mechanical damage. Inductance variation: Within $\pm 10\%$ Q variation: Within $\pm 20\%$	Keep a test sample in an atmosphere with a temperature of $85 \pm 2^\circ\text{C}$ for 500 ± 12 hours. After the test, keep the test sample at a normal temperature with a normal humidity for 1 to 2 hours, then carry out measurement.
5. 6	Humidity resistance load life test	Same as above	Solder a test sample to the printed circuit board shown in Attached Drawing 2 and keep it in an atmosphere with a temperature of $60 \pm 2^\circ\text{C}$ with a relative humidity of 90 to 95% for 500 ± 12 hours while supplying the allowable current. After the test, keep the sample at a normal temperature with a normal humidity for 1 to 2 hours, then carry out measurement.
5. 7	High temperature load life test	Same as above	Solder a test sample to the printed circuit board shown in Attached Drawing 2 and keep it in an atmosphere with a temperature of $85 \pm 2^\circ\text{C}$ for 500 ± 12 hours while supplying the rated current. After the test, keep the test sample at a normal temperature with a normal humidity for 1 to 2 hours, then carry out measurement.

[5] Chip Inductor Reliability Test

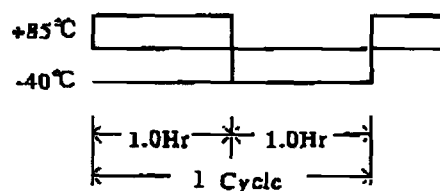
Order	Item	Specification	Testing Method
5. 8	Coldness resistance test	To be free from mechanical damage. Inductance variation: Within $\pm 10\%$ Q variation: Within $\pm 20\%$	Keep a test sample in an atmosphere with a temperature of $-40 \pm 2^\circ\text{C}$ for 500 ± 12 hours. After the test, keep the test sample at a normal temperature with a normal humidity for 1 to 2 hours, then carry out measurement.
5. 9	Thermal shock test	Same as above	Solder a test sample to the printed circuit board shown in Attached Drawing 2 and conduct 100 cycle of test under the conditions shown below.  <p>The diagram shows a temperature profile for one cycle. It starts at $+85^\circ\text{C}$ for 1.0 hour, then drops to -40°C for 1.0 hour, and then returns to $+85^\circ\text{C}$. The total duration of one cycle is 1.0 hour.</p>
5. 10	Resistance to soldering heat test	To be free from mechanical damage. Exposure ratio of the terminal: 70% min.	Immerse a test sample in a methanol (JIS K1501) solution containing rosin (JIS K5902) (weight ratio 25%), preheat it at 150 to 180°C for 2 to 3 minutes and immerse it into a solder hot melt (H63A or H60 A specified in JIS Z3282) of $260 \pm 5^\circ\text{C}$ for 10 ± 0.5 seconds.

[5] Chip Inductor Reliability Test

Order	Item	Specification	Testing Method
5. 11	Solderability test	75% or over of terminal electrodes shall be covered with fresh solder.	Immerse a test sample in a methanol solution containing rosin shown in Item 5.10 for 3 to 5 seconds, preheat it at 150 to 180°C for 2 to 3 minutes and immerse it into a solder hot melt of $230 \pm 5^\circ\text{C}$ for 4 ± 1 seconds.
5. 12	Temperature characteristic	Inductance variation: within $\pm 10\%$	Measurements were taken in a temperature range of -30 to $+85^\circ\text{C}$ and the value at $+20^\circ\text{C}$ was used as the standard value.

[6] Taping Specification
6-1 Marking and Reel Dimensions

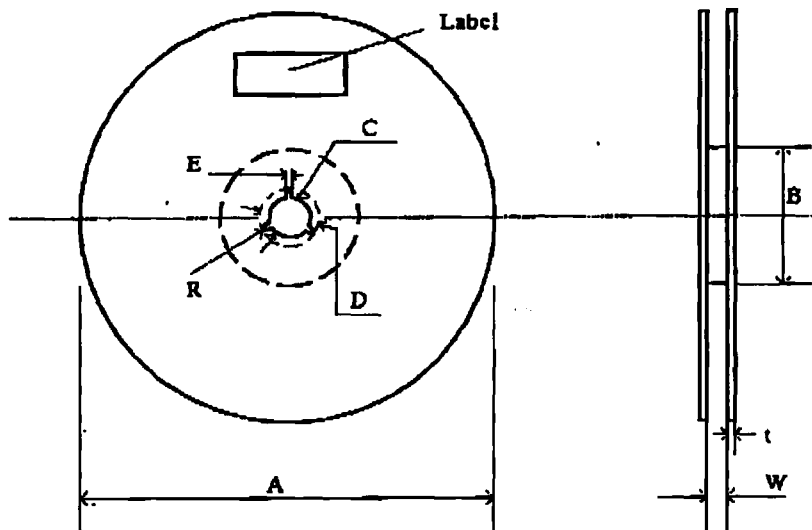

Items for Marking

- 1) Manufacturer's name
- 2) Part No.
- 3) Customer's Part No.
- 4) Quantity
- 5) Lot No.

Symbol	ϕA	ϕB	ϕC	ϕD
Dimensions	178 ± 2.0	60 ± 2.0	13 ± 0.5	21 ± 0.8

Symbol	E	W	t	R
Dimensions	2.0 ± 0.5	10 ± 1.5	1.5 max	1.0

Unit : mm

6-2 External Dimensions of plastics Tape

The external dimensions of the plastics tape are as shown below :

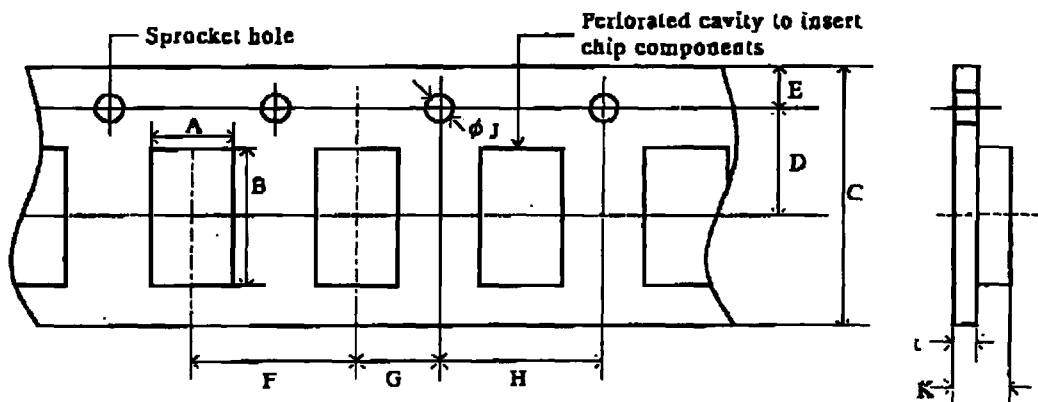

Symbol	A	B	C	D	E
Dimensions	1.5 ± 0.2	2.3 ± 0.2	8.0 ± 0.3	3.5 ± 0.05	1.75 ± 0.1

Symbol	F	G	H	ϕJ	t
Dimensions	4.0 ± 0.1	2.0 ± 0.05	4.0 ± 0.1	1.5 ± 0.1	0.3max

K	Thickness = 0.85	1.5max
	Thickness = 1.00	2max

Unit : mm

6-3 Packaging Mode

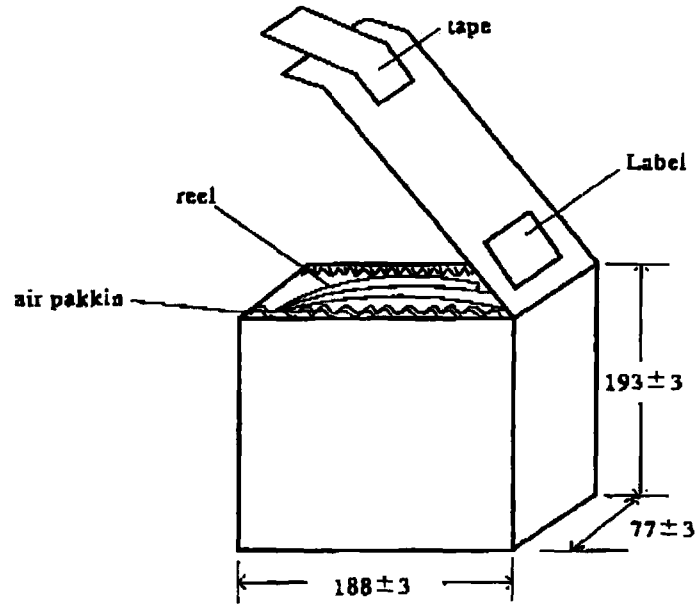
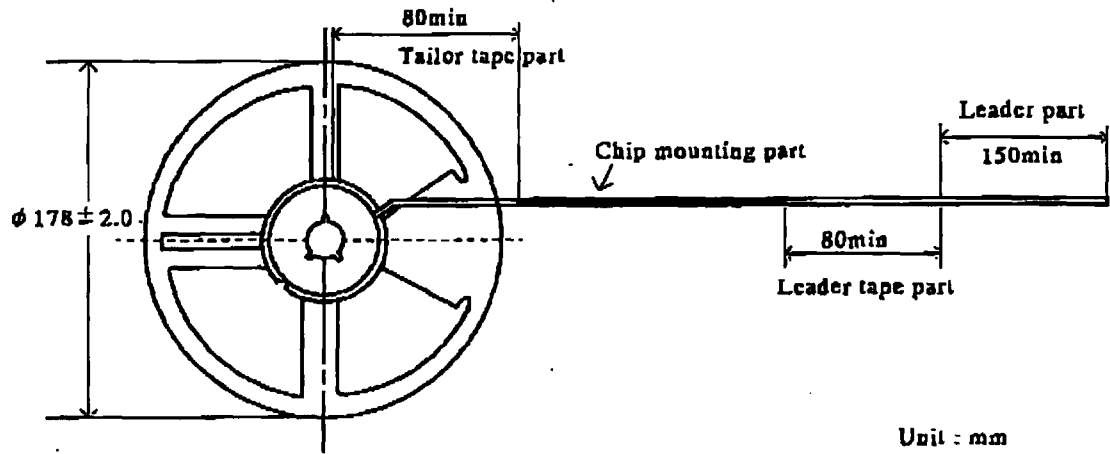

Items for Marking

- 1) Manufacturer's name
- 2) Part No.
- 3) Customer's Part No.
- 4) Quantity
- 5) Lot No.

6-4 Quantity of products to be packaged

TYPE	Thickness T	1 reel	1 carton box
HK 2125	0.85 mm	4,000 / reel	20,000 / 5reels
	1.00 mm	3,000 / reel	15,000 / 5reels

[7] Cautions in Handling for Mounting

Before soldering, preheating shall be carried out. The difference of the preheating temperature from the solder temperature the chip temperature shall be within 150 °C.

When installing a printed circuit board on which chips shall be free from a residual stress due to overall strain of the printed circuit board or local strain resulting from tightening of screws. Soldering by soldering iron shall be completed within 3 seconds at less than 260 °C. In addition, it is noted that the point of soldering iron shall not be directly touched to terminal electrode. at soldering, please take care the solder is not excessively put on the electrode of the chip.

In case solder is too much put on the electrode, excessive stress is applied to the chip. It may damage the chip.

Use rosin-type flux and do not use a highly acidic flux. (any containing a minimum of 0.2wt% chlorine)

[8] Cautions on washing

Freon, Chlorosen, Triclen, Alcohol, etc, are used as solvent of washing process.

However, some of them are restricted, due to negative influence to human body and/or destruction of the environment.

Solvent shall be selected with care. Effect to the other parts shall be considered at washing.

[9] Cautions for keeping the products

About storage of the products, surrounding temperature is less 40 °C and humidity is less than 70%RH.

And please store the products in the place where poisonous gases such as sulfur, chlorine, etc do not exist in the atmosphere, and please use it as within six months as possible.

[10] Recommendable Soldering

Recommended temperature profile in reflow soldering

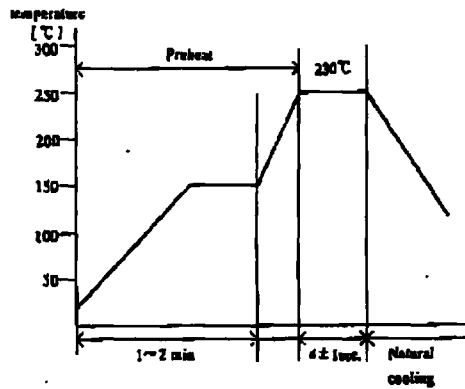

Recommended temperature profile in flow soldering

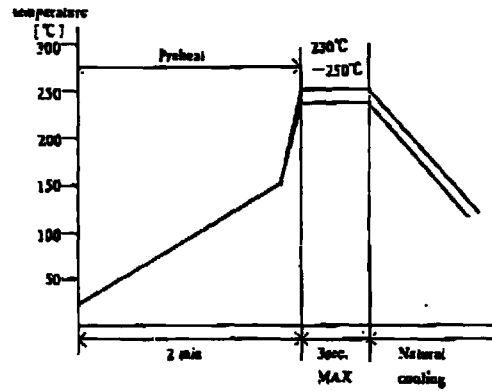

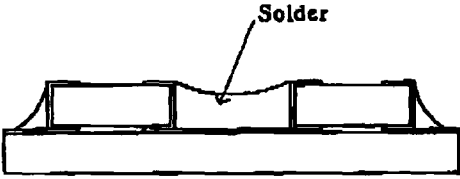
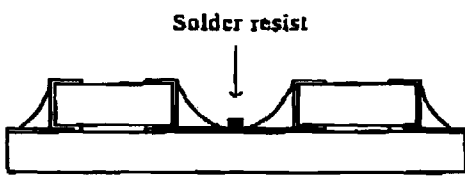
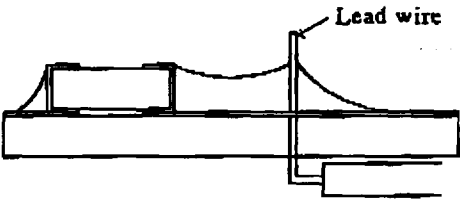
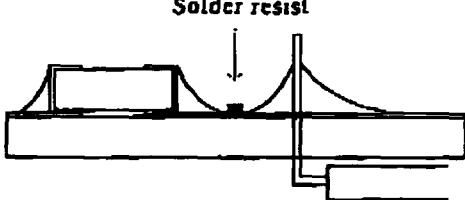
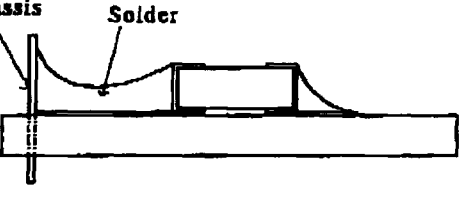
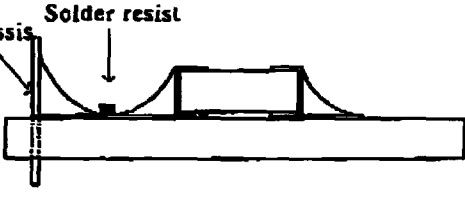
Bad solder finishing	Good solder finishing
 <p>Solder</p>	 <p>Solder resist</p>
 <p>Lead wire</p>	 <p>Solder resist</p>
 <p>Chassis Solder</p>	 <p>Chassis Solder resist</p>

The operating conditions for the guarantee of this product are as shown in the specification.

Please note that Taiyo Yuden Co., Ltd. shall not be responsible for a failure and/or abnormality which are caused by use under the conditions other than the aforesaid operating conditions.

Attached Drawing 1
Instrument for Deflection Test

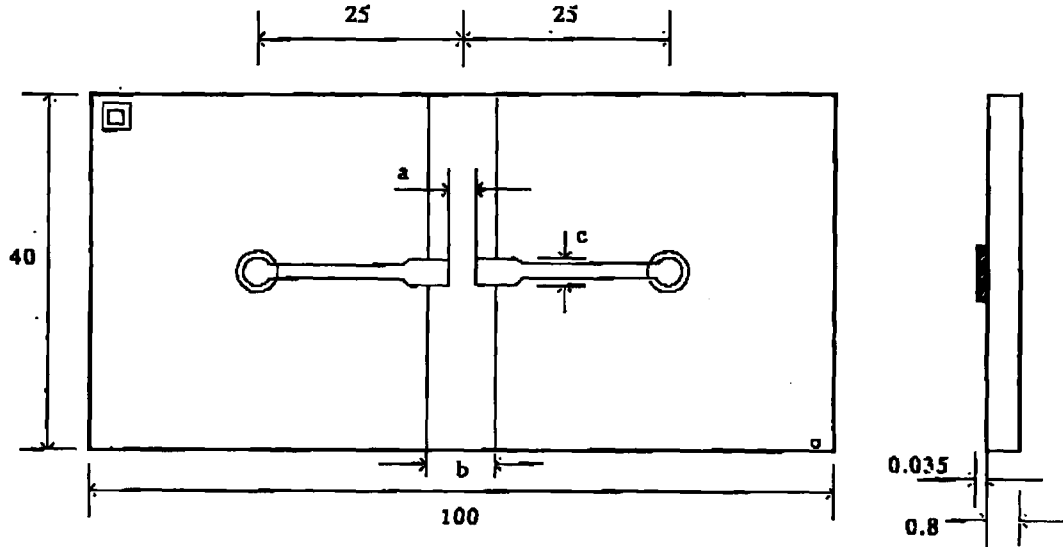

Unit : mm

Specification
Glass cloth-based epoxy resin
Type GE 4 specified in JIS C6484
Thickness 0.8mm

Chip Size	a	b	c
2.0 × 1.25	1.2	4.0	1.65

Unit : mm

Attached Drawing 2 printed Circuit Board for Reliability Test

Printed circuit board for the reliability test

Material : Glass epoxy

Thickness : 1.6 mm

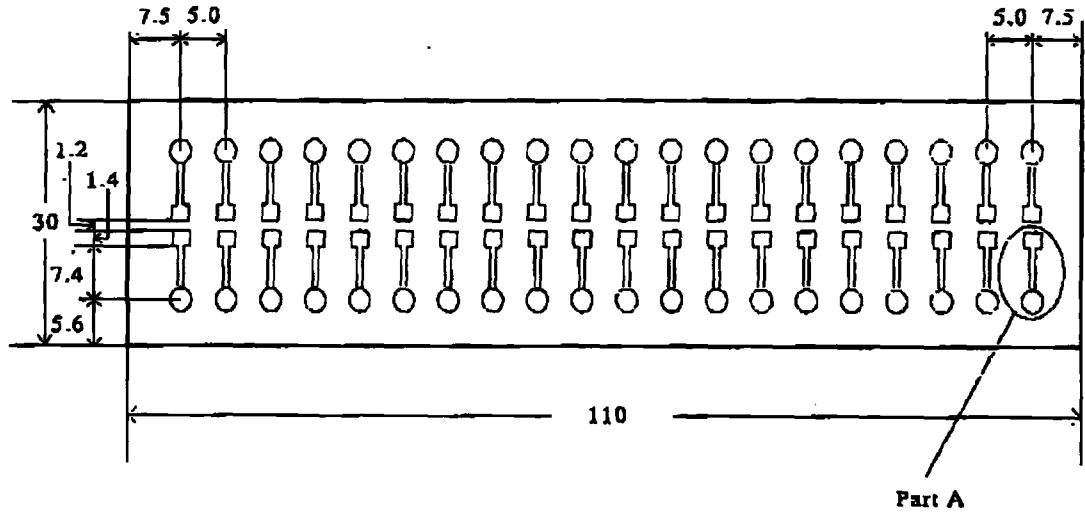

Part A

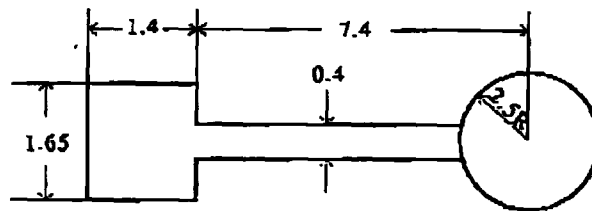

Unit: mm

HK2125 FREQUENCY CHARACTERISTICS

