



Advance Information

Micropower smallCAP™ Voltage Regulators with On/Off Control

The MC33264 series are micropower low dropout voltage regulators available in SO-8 and Micro-8 surface mount packages and a wide range of output voltages. These devices feature a very low quiescent current (100 μ A in the ON mode; 0.1 μ A in the OFF mode), and are capable of supplying output currents up to 100 mA. Internal current and thermal limiting protection is provided. They require only a small output capacitance for stability.

Additionally, the MC33264 has either active HIGH or active LOW control (Pins 2 and 3) that allows a logic level signal to turn-off or turn-on the regulator output.

Due to the low input-to-output voltage differential and bias current specifications, these devices are ideally suited for battery powered computer, consumer, and industrial equipment where an extension of useful battery life is desirable.

MC33264 Features:

- Low Quiescent Current (0.3 μ A in OFF Mode; 95 μ A in ON Mode)
- Low Input-to-Output Voltage Differential of 47 mV at 10 mA, and 131 mV at 50 mA
- Multiple Output Voltages Available
- Extremely Tight Line and Load Regulation
- Stable with Output Capacitance of Only
0.22 μ F for 4.0 V, 4.75 V and 5.0 V Output Voltages
0.33 μ F for 2.8 V, 3.0 V, 3.3 V and 3.8 V Output Voltages
- Internal Current and Thermal Limiting
- Logic Level ON/OFF Control
- Functionally Equivalent to TK115XXMC and LP2980

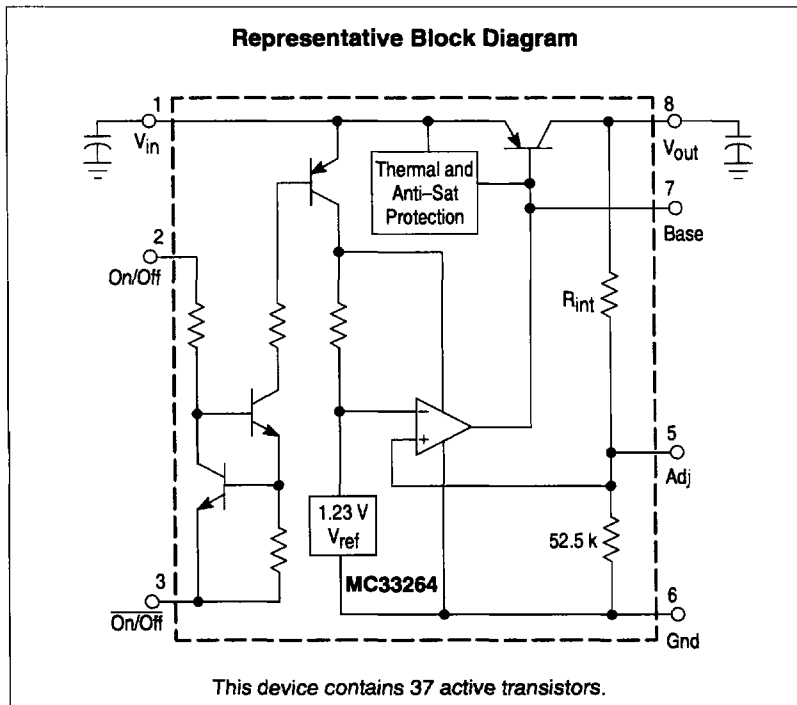

MC33264

LOW DROPOUT MICROPOWER VOLTAGE REGULATORS WITH ON/OFF CONTROL

SEMICONDUCTOR
TECHNICAL DATA

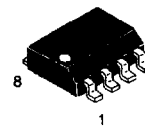

D SUFFIX
PLASTIC PACKAGE
CASE 751
(SO-8)

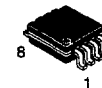

DM SUFFIX
PLASTIC PACKAGE
CASE 846A
(Micro-8)

PIN CONNECTIONS

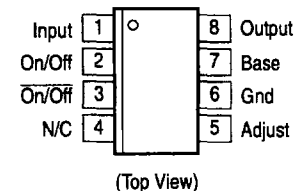

ORDERING INFORMATION

Device	Operating Temperature Range	Package
MC33264D-2.8 MC33264D-3.0 MC33264D-3.3 MC33264D-3.8 MC33264D-4.0 MC33264D-4.75 MC33264D-5.0	T _A = -40° to +85°C	SO-8
MC33264DM-2.8 MC33264DM-3.0 MC33264DM-3.3 MC33264DM-3.8 MC33264DM-4.0 MC33264DM-4.75 MC33264DM-5.0		Micro-8

MOTOROLA

MC33264

MAXIMUM RATINGS (T_C = 25°C, unless otherwise noted.)

Rating	Symbol	Value	Unit
Input Voltage	V _{CC}	13	Vdc
Power Dissipation and Thermal Characteristics			
Maximum Power Dissipation	P _D	Internally Limited	W
Case 751 (SO-8) D Suffix			
Thermal Resistance, Junction-to-Ambient	R _{θJA}	180	°C/W
Thermal Resistance, Junction-to-Case	R _{θJC}	45	°C/W
Case 846A (Micro-8) DM Suffix			
Thermal Resistance, Junction-to-Ambient	R _{θJA}	240	°C/W
Output Current	I _O	100	mA
Maximum Adjustable Output Voltage	V _O	1.15 × V _{nom}	Vdc
Operating Junction Temperature	T _J	125	°C
Operating Ambient Temperature	T _A	-40 to +85	°C
Storage Temperature Range	T _{stg}	-65 to +150	°C

NOTE: ESD data available upon request.

ELECTRICAL CHARACTERISTICS (V_{in} = 6.0 V, I_O = 10 mA, C_O = 1.0 μF, T_J = 25°C (Note 1), unless otherwise noted.)

Characteristic	Symbol	Min	Typ	Max	Unit
Output Voltage (I _O = 0 mA)	V _O				V
2.8 Suffix (V _{CC} = 3.8 V)		2.74	2.8	2.86	
3.0 Suffix (V _{CC} = 4.0 V)		2.96	3.0	3.04	
3.3 Suffix (V _{CC} = 4.3 V)		3.23	3.3	3.37	
3.8 Suffix (V _{CC} = 4.8 V)		3.72	3.8	3.88	
4.0 Suffix (V _{CC} = 5.0 V)		3.92	4.0	4.08	
4.75 Suffix (V _{CC} = 5.75 V)		4.66	4.75	4.85	
5.0 Suffix (V _{CC} = 6.0 V)		4.9	5.0	5.1	
V _{in} = (V _O + 1.0) V to 12 V, I _O < 60 mA, T _A = -40° to +85°C					
2.8 Suffix		2.7	-	2.9	
3.0 Suffix		2.9	-	3.1	
3.3 Suffix		3.18	-	3.42	
3.8 Suffix		3.67	-	3.93	
4.0 Suffix		3.86	-	4.14	
4.75 Suffix		4.58	-	4.92	
5.0 Suffix		4.83	-	5.17	
Line Regulation (V _{in} = [V _O + 1.0] V to 12 V, I _O = 60 mA) All Suffixes	Reg _{line}	-	2.0	10	mV
Load Regulation (V _{in} = [V _O + 1.0], I _O = 0 mA to 60 mA) All Suffixes	Reg _{load}	-	16	25	mV
Dropout Voltage	V _I - V _O				mV
I _O = 10 mA		-	47	90	
I _O = 50 mA		-	131	200	
I _O = 60 mA		-	147	230	
Quiescent Current	I _Q				μA
ON Mode (V _{in} = [V _O + 1.0] V, I _O = 0 mA)		-	95	150	
OFF Mode		-	0.3	2.0	
ON Mode (V _{in} = [V _O + 0.5] V, I _O = 0 mA) [Note2]		-	540	900	
Ripple Rejection (V _{in} peak-to-peak = [V _O + 1.5] to [V _O + 5.5] V at f = 1.0 kHz)	-	55	65	-	dB
Output Voltage Temperature Coefficient	TC	-	±120	-	ppm/°C
Current Limit (V _{in} = [V _O + 1.0], V _O Shorted)	I _{Limit}	100	150	-	mA
Output Noise Voltage (10 Hz to 100 kHz) (Note 3)	V _n				μVrms
C _L = 1.0 μF		-	110	-	
C _L = 100 μF		-	46	-	

NOTES: 1. Low duty pulse techniques are used during test to maintain junction temperature as close to ambient as possible.
2. Quiescent current is measured where the PNP pass transistor is in saturation. V_{CE} = -0.5 V guarantees this condition.
3. Noise tests on the MC33264 are made with a 0.01 μF capacitor connected across Pins 8 and 5.

MC33264

ELECTRICAL CHARACTERISTICS (continued) ($V_{in} = 6.0\text{ V}$, $I_O = 10\text{ mA}$, $C_O = 1.0\text{ }\mu\text{F}$, $T_J = 25^\circ\text{C}$ (Note 1), unless otherwise noted.)

Characteristic	Symbol	Min	Typ	Max	Unit
ON/OFF INPUTS					
On/Off Input (Pin 3 Tied to Ground) Logic "1" (Regulator ON) Logic "0" (Regulator OFF)	$V_{On/Off}$	2.4	–	V_{in}	V
0		–	0.5		
On/Off Input (Pin 2 Tied to V_{in}) Logic "0" (Regulator ON) Logic "1" (Regulator OFF)		0	–	$V_{in} - 2.4$	
$V_{in} - 0.2$		–	V_{in}		
On/Off Pin Input Current (Pin 3 Tied to Ground) $V_{On/Off} = 2.4\text{ V}$	$I_{On/Off}$	–	1.9	–	μA
On/Off Pin Input Current (Pin 2 Tied to V_{in}) $V_{On/Off} = V_{in} - 2.4\text{ V}$		–	12	–	

- NOTES:** 1. Low duty pulse techniques are used during test to maintain junction temperature as close to ambient as possible.
2. Quiescent current is measured where the PNP pass transistor is in saturation. $V_{CE} = -0.5\text{ V}$ guarantees this condition.
3. Noise tests on the MC33264 are made with a $0.01\text{ }\mu\text{F}$ capacitor connected across Pins 8 and 5.

DEFINITIONS

Dropout Voltage – The input/output voltage differential at which the regulator output no longer maintains regulation against further reductions in input voltage. Measured when the output drops 100 mV below its nominal value (which is measured at 1.0 V differential), dropout voltage is affected by junction temperature, load current and minimum input supply requirements.

Line Regulation – The change in output voltage for a change in input voltage. The measurement is made under conditions of low dissipation or by using pulse techniques such that average chip temperature is not significantly affected.

Load Regulation – The change in output voltage for a change in load current at constant chip temperature.

Maximum Power Dissipation – The maximum total device dissipation for which the regulator will operate within specifications.

Quiescent Current – Current which is used to operate the regulator chip and is not delivered to the load.

Output Noise Voltage – The rms ac voltage at the output, with constant load and no input ripple, measured over a specified frequency range.

Figure 1. Quiescent Current versus Load Current

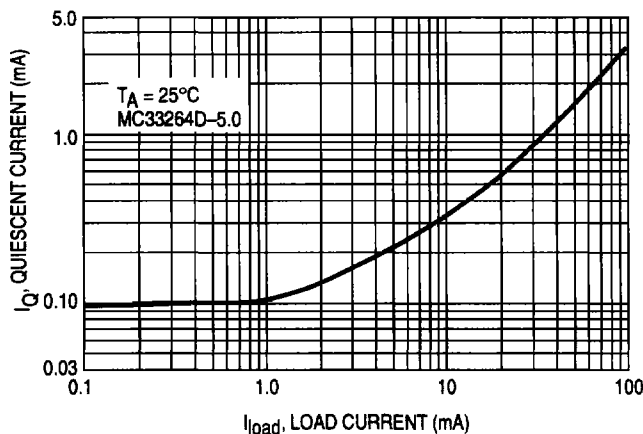

Figure 2. Output Voltage versus Input Voltage

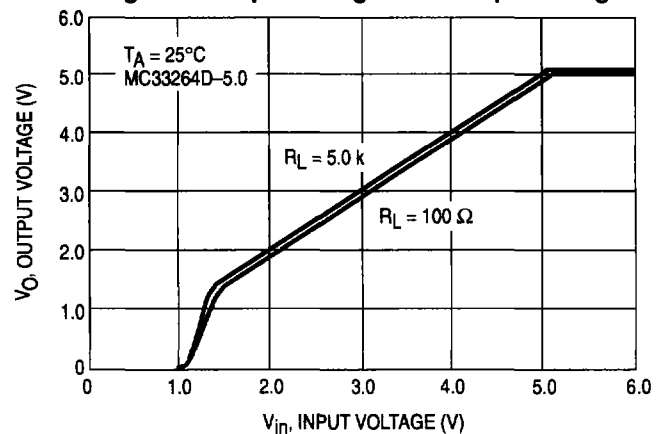

Figure 3. Input Current versus Input Voltage

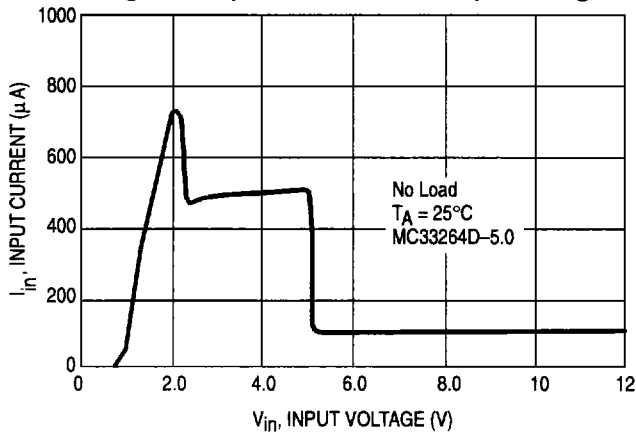

Figure 4. Output Voltage versus Temperature

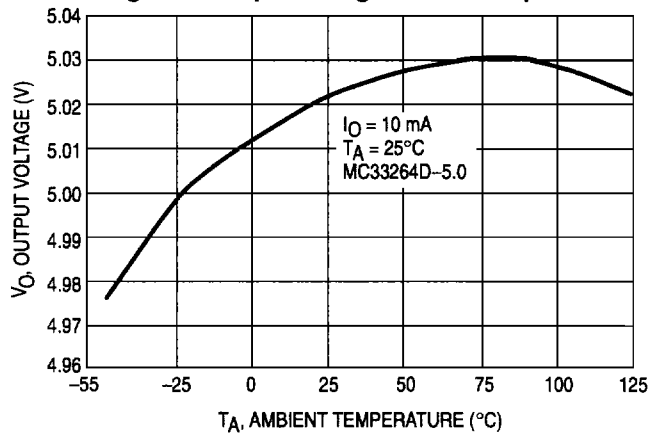

Figure 5. Dropout Voltage versus Output Current

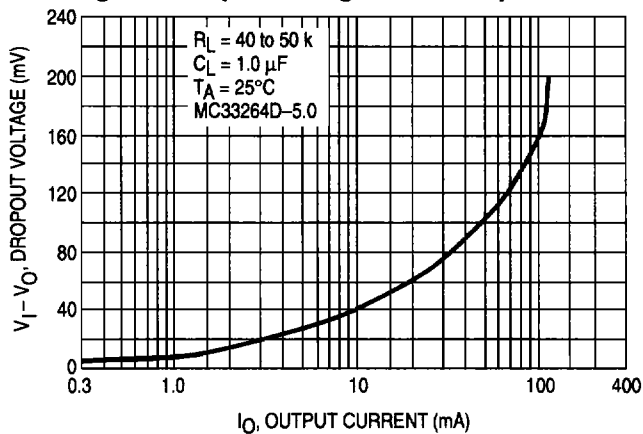
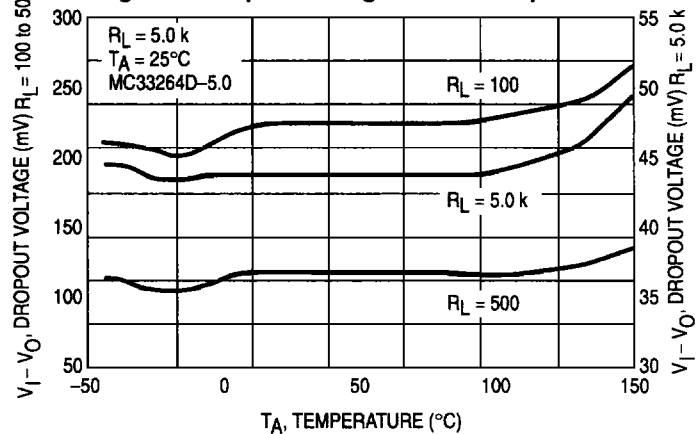

Figure 6. Dropout Voltage versus Temperature



APPLICATION INFORMATION

Introduction

The MC33264 regulators are designed with internal current limiting and thermal shutdown making them user-friendly. These regulators require only 0.33 µF (or greater) capacitance between the output terminal and ground for stability for 2.8 V, 3.0 V, 3.3 V and 3.8 V output voltage options. Output voltage options of 4.0 V, 4.75 V and 5.0 V require only 0.22 µF for stability. The output capacitor must be mounted as close to the MC33264 as possible. If the output capacitor must be mounted further than two centimeters away from the MC33264, then a larger value of output capacitor may be required for stability. A value of 0.68 µF or larger is recommended. Most types of aluminum, tantalum or multilayer ceramic will perform adequately. Solid tantalum or appropriate multilayer ceramic capacitors are recommended for operation below 25°C.

A bypass capacitor is recommended across the MC33264 input to ground if more than 4.0 inches of wire connects the input to either a battery or power supply filter capacitor.

On/Off Control

On/Off control of the regulator may be accomplished in either of two ways. Pin 3 may be tied to circuit ground and a positive logic control applied to Pin 2. The regulator will be turned on by a positive (>2.4 V) level, typically 5.0 V with respect to ground, sourcing a typical current of 6.0 µA. The regulator will turn off if the control input is a logic "0" (<0.5 V). Alternatively, Pin 2 may be tied to the regulator input voltage and a negative logic control applied to Pin 3. The regulator will be turned on when the control voltage is less than $V_{in} - 2.4$ V, sinking a typical current of 18 µA when $V_{in} = 6.0$ V. The regulator is off when the control input is open or greater than $V_{in} - 0.2$ V.

Programming The Output Voltage

The MC33264 output voltage is automatically set using its internal voltage divider. Alternatively, it may be programmed within a typical ±15% range of its preset output voltage. An external pair of resistors is required, as shown in Figure 7.

MC33264

Figure 7. Regulator Output Voltage Trim

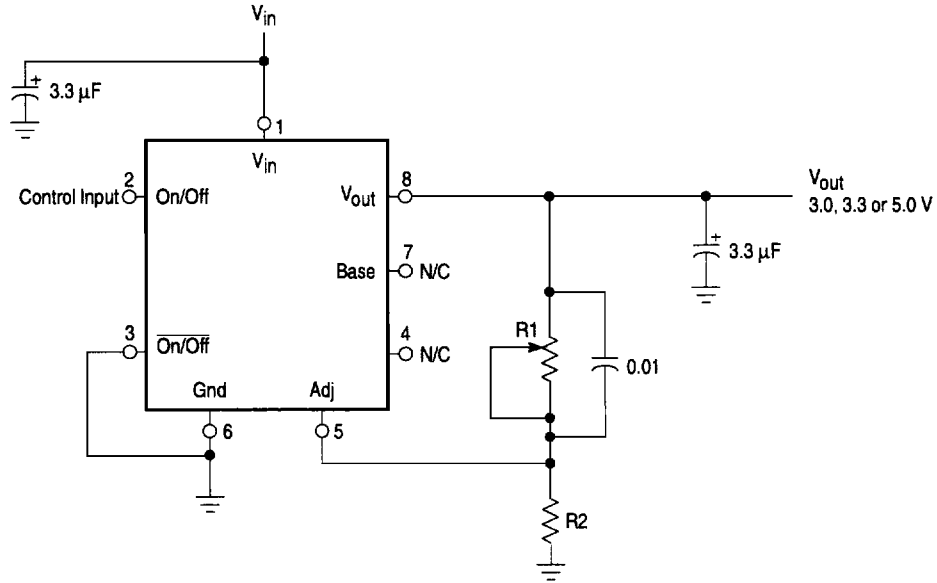

The complete equation for the output voltage is:

$$V_{out} = V_{ref} \left(1 + \frac{R1}{R2} \right) + I_{FB} R1$$

where V_{ref} is the nominal 1.235 V reference voltage and I_{FB} is the feedback pin bias current, nominally -20 nA. The minimum recommended load current of 1.0 μ A forces an upper limit of 1.2 M Ω on the value of $R2$, if the regulator must work with no load. I_{FB} will produce a 2% typical error in V_{out} which may be eliminated at room temperature by adjusting $R1$. For better accuracy, choosing $R2 = 100$ K reduces this error to 0.17% while increasing the resistor program current to 12 μ A.

Output Noise

In many applications it is desirable to reduce the noise present at the output. Reducing the regulator bandwidth by

increasing the size of the output capacitor is the only method for reducing noise.

Noise can be reduced fourfold by a bypass capacitor across $R1$, since it reduces the high frequency gain from 4 to unity for the MC33264D-5.0. Pick

$$C_{BYPASS} = \frac{1}{2\pi R1 \times 200 \text{ Hz}}$$

or about 0.01 μ F. When doing this, the output capacitor must be increased to 3.3 μ F to maintain stability. These changes reduce the output noise from 430 μ V to 100 Vrms for a 100 kHz bandwidth for the 5.0 V output device. With the bypass capacitor added, noise no longer scales with output voltage so that improvements are more dramatic at higher output voltages.

TYPICAL APPLICATIONS

Figure 8. Lithium Ion Battery Cell Charger

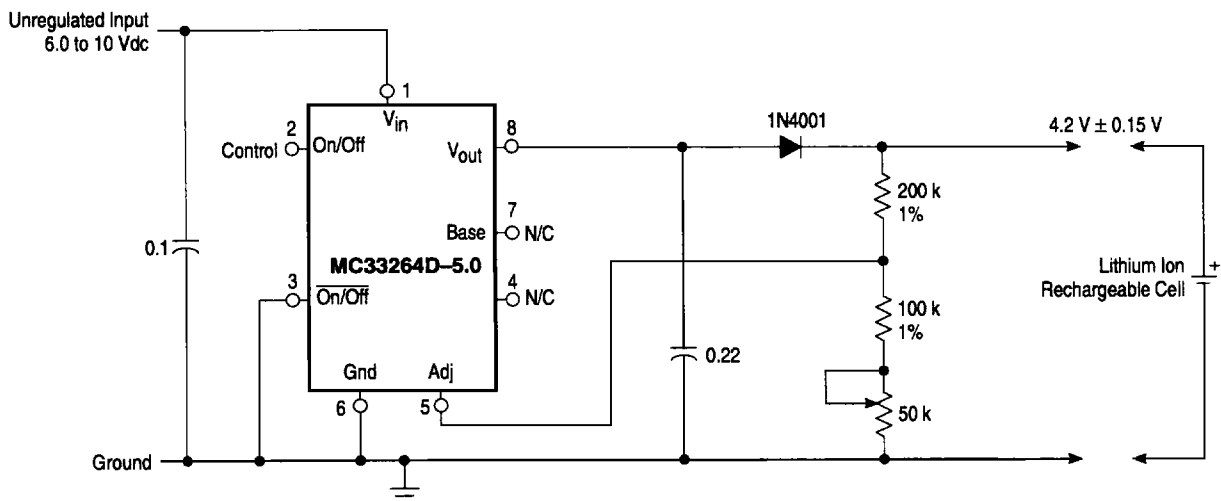

MC33264

Figure 9. Low Drift Current Source

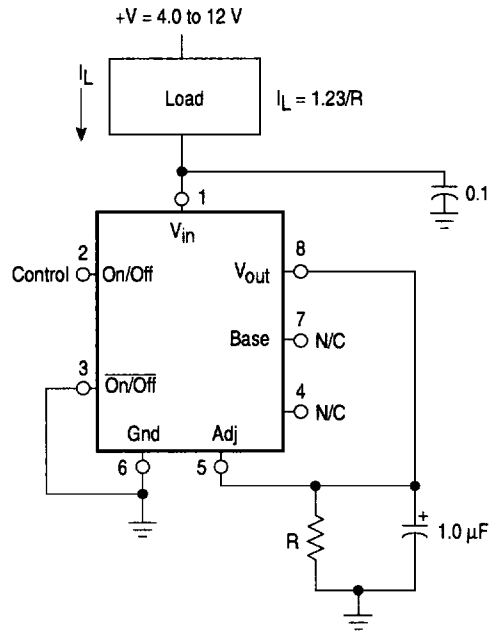
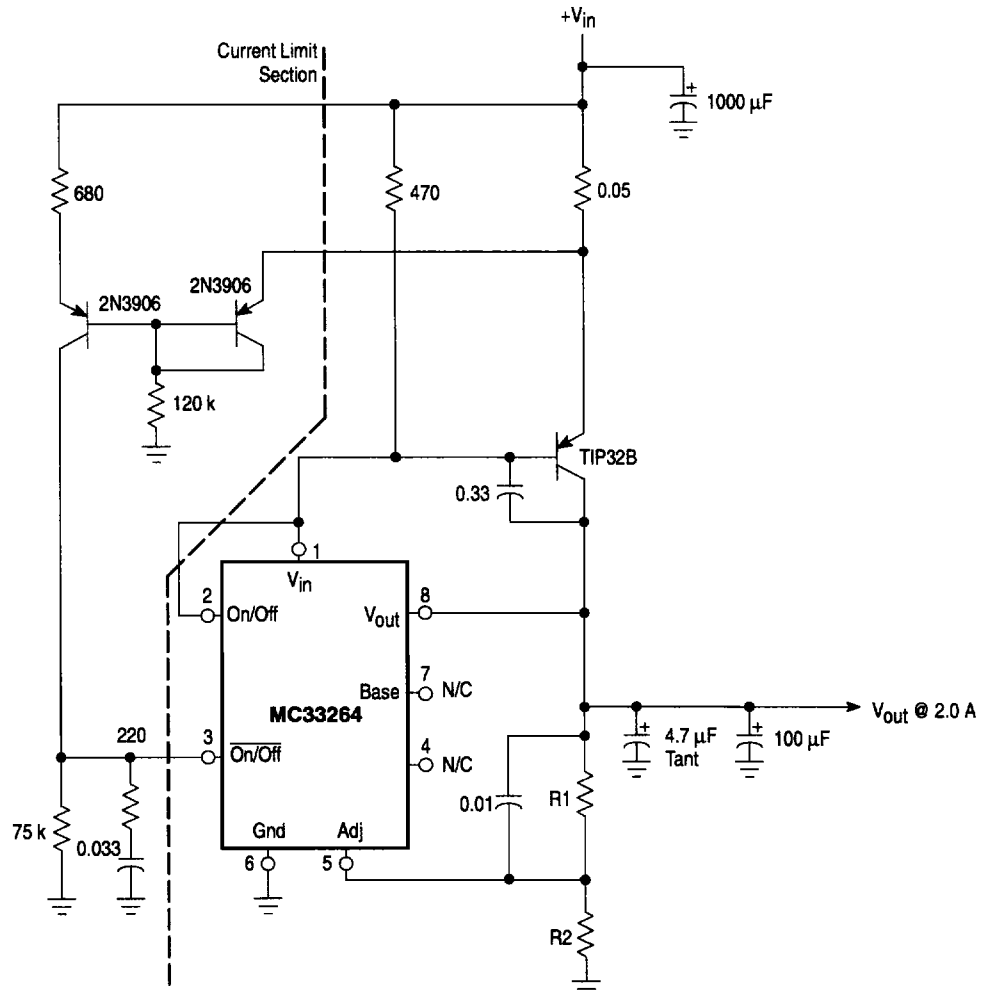

Figure 10. 2.0 Ampere Low Dropout Regulator



MC33264

Figure 11. Low Battery Disconnect

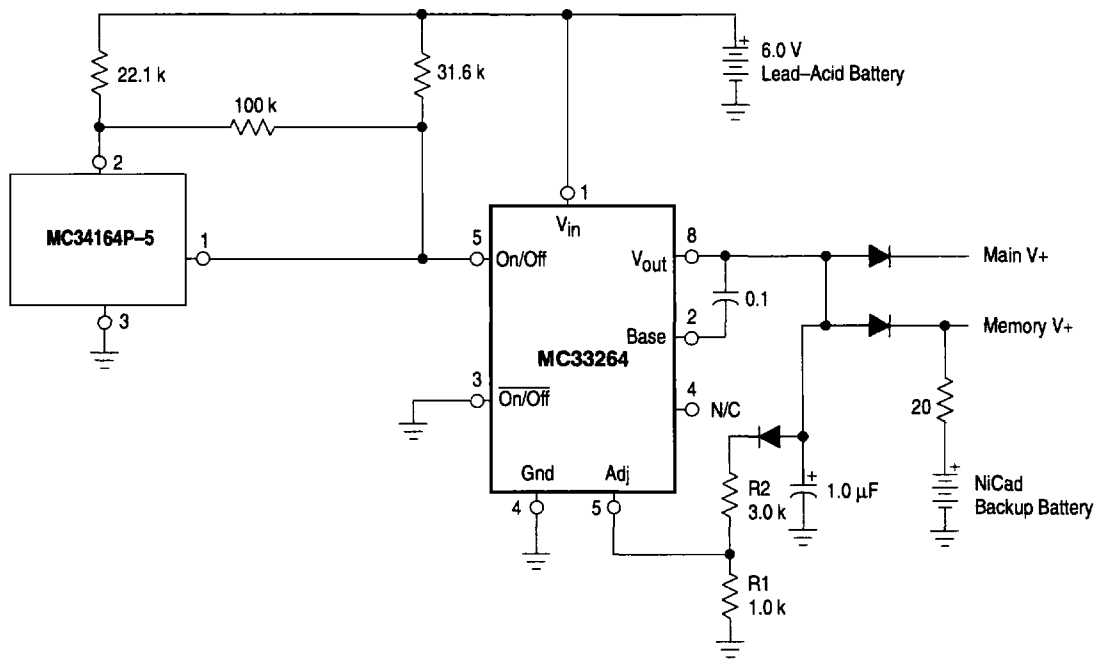
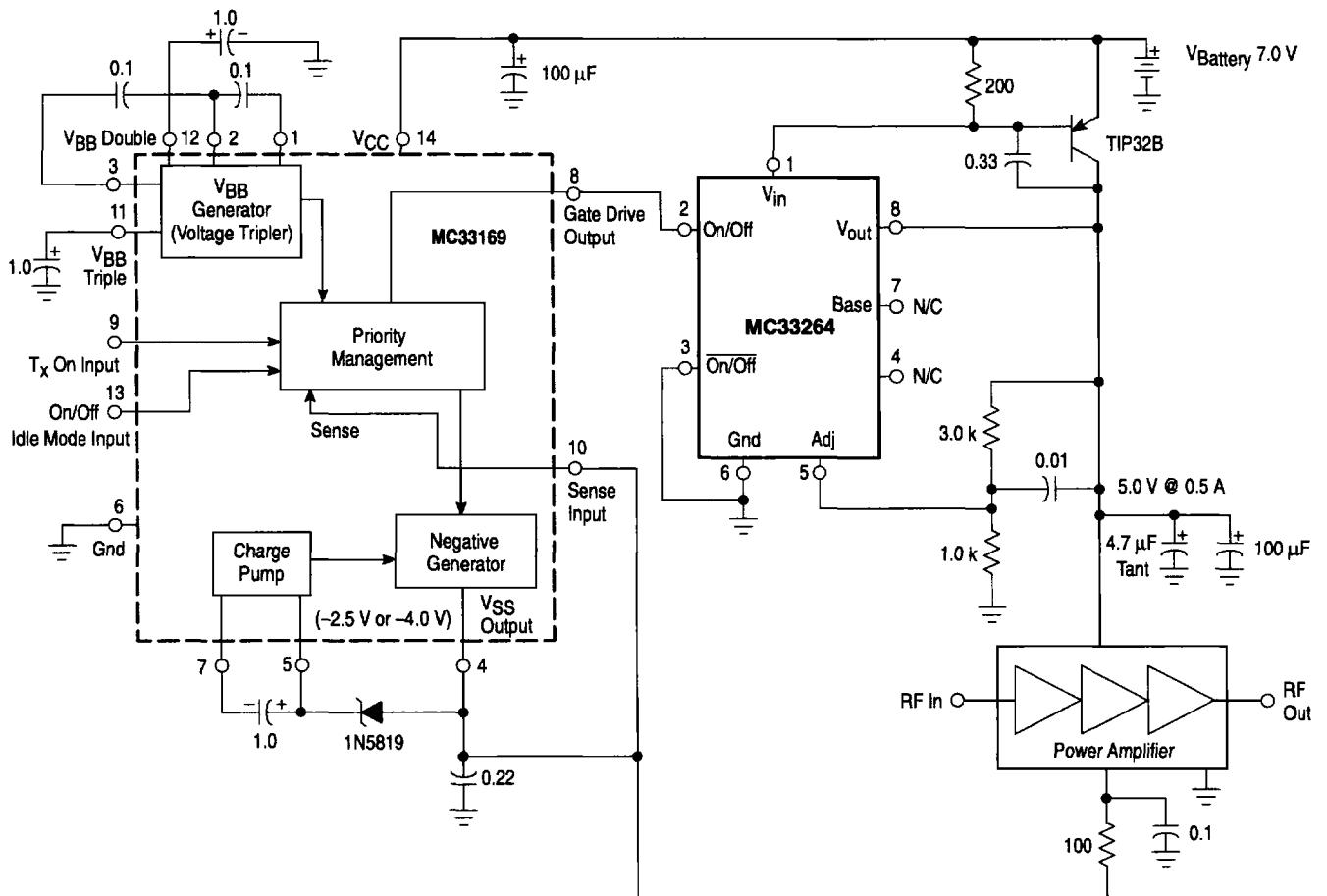

Figure 12. RF Amplifier Supply



MC33264

OUTLINE DIMENSIONS

D SUFFIX
PLASTIC PACKAGE
CASE 751-05
(SO-8)
ISSUE R

NOTES:

- DIMENSIONING AND TOLERANCING PER ASME Y14.5M, 1994.
- DIMENSIONS ARE IN MILLIMETERS.
- DIMENSION D AND E DO NOT INCLUDE MOLD PROTRUSION.
- MAXIMUM MOLD PROTRUSION 0.15 PER SIDE.
- DIMENSION B DOES NOT INCLUDE MOLD PROTRUSION. ALLOWABLE DAMBAR PROTRUSION SHALL BE 0.127 TOTAL IN EXCESS OF THE B DIMENSION AT MAXIMUM MATERIAL CONDITION.

MILLIMETERS		
DIM	MIN	MAX
A	1.35	1.75
A1	0.10	0.25
B	0.35	0.49
C	0.18	0.25
D	4.80	5.00
E	3.80	4.00
e	1.27 BSC	
H	5.80	6.20
h	0.25	0.50
L	0.40	1.25
θ	0°	7°

DM SUFFIX
PLASTIC PACKAGE
CASE 846A-02
(Micro-8)
ISSUE C

NOTES:

- DIMENSIONING AND TOLERANCING PER ANSI Y14.5M, 1982.
- CONTROLLING DIMENSION: MILLIMETER.
- DIMENSION A DOES NOT INCLUDE MOLD FLASH, PROTRUSIONS OR GATE BURRS. MOLD FLASH, PROTRUSIONS OR GATE BURRS SHALL NOT EXCEED 0.15 (0.006) PER SIDE.
- DIMENSION B DOES NOT INCLUDE INTERLEAD FLASH OR PROTRUSION. INTERLEAD FLASH OR PROTRUSION SHALL NOT EXCEED 0.25 (0.010) PER SIDE.

DIM	MILLIMETERS		INCHES	
	MIN	MAX	MIN	MAX
A	2.90	3.10	0.114	0.122
B	2.90	3.10	0.114	0.122
C	—	1.10	—	0.043
D	0.25	0.40	0.010	0.016
G	0.65 BSC		0.026 BSC	
H	0.05	0.15	0.002	0.006
J	0.13	0.23	0.005	0.009
K	4.75	5.05	0.187	0.199
L	0.40	0.70	0.016	0.028

Motorola reserves the right to make changes without further notice to any products herein. Motorola makes no warranty, representation or guarantee regarding the suitability of its products for any particular purpose, nor does Motorola assume any liability arising out of the application or use of any product or circuit, and specifically disclaims any and all liability, including without limitation consequential or incidental damages. "Typical" parameters which may be provided in Motorola data sheets and/or specifications can and do vary in different applications and actual performance may vary over time. All operating parameters, including "Typicals" must be validated for each customer application by customer's technical experts. Motorola does not convey any license under its patent rights nor the rights of others. Motorola products are not designed, intended, or authorized for use as components in systems intended for surgical implant into the body, or other applications intended to support or sustain life, or for any other application in which the failure of the Motorola product could create a situation where personal injury or death may occur. Should Buyer purchase or use Motorola products for any such unintended or unauthorized application, Buyer shall indemnify and hold Motorola and its officers, employees, subsidiaries, affiliates, and distributors harmless against all claims, costs, damages, and expenses, and reasonable attorney fees arising out of, directly or indirectly, any claim of personal injury or death associated with such unintended or unauthorized use, even if such claim alleges that Motorola was negligent regarding the design or manufacture of the part. Motorola and are registered trademarks of Motorola, Inc. Motorola, Inc. is an Equal Opportunity/Affirmative Action Employer.

Mfax is a trademark of Motorola, Inc.

How to reach us:

USA/EUROPE/Locations Not Listed: Motorola Literature Distribution;
 P.O. Box 5405, Denver, Colorado 80217. 303-675-2140 or 1-800-441-2447

JAPAN: Nippon Motorola Ltd.: SPD, Strategic Planning Office, 4-32-1,
 Nishi-Gotanda, Shinagawa-ku, Tokyo 141, Japan. 81-3-5487-8488

Mfax™: RMFAX0@email.sps.mot.com - TOUCHTONE 602-244-6609
 - US & Canada ONLY 1-800-774-1848

ASIA/PACIFIC: Motorola Semiconductors H.K. Ltd.; 8B Tai Ping Industrial Park,
 51 Ting Kok Road, Tai Po, N.T., Hong Kong. 852-26629298

INTERNET: <http://motorola.com/sps>

