



North/Latin America  
Europe/Africa  
Asia/Oceania

Internal Use Only

<http://aic.lgservice.com>  
<http://eic.lgservice.com>  
<http://biz.lgservice.com>

# PLASMA TV

# SERVICE MANUAL

CHASSIS : PD01A

**MODEL : 42PJ350                      42PJ350-ZA**

## CAUTION

BEFORE SERVICING THE CHASSIS,  
READ THE SAFETY PRECAUTIONS IN THIS MANUAL.

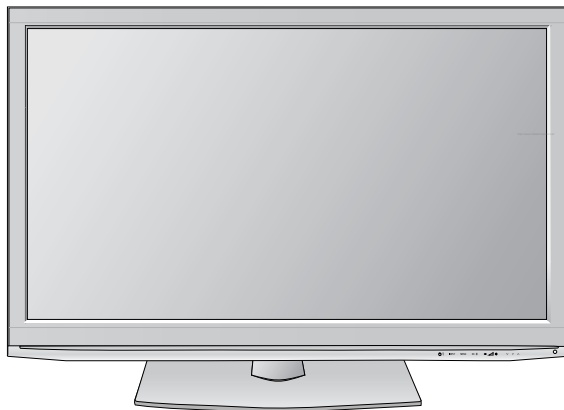

P/NO : MFL62881211(1001-REV00)

Printed in Korea

# CONTENTS

<b>CONTENTS .....</b>	<b>2</b>
<b>SAFETY PRECAUTIONS .....</b>	<b>3</b>
<b>SPECIFICATION .....</b>	<b>4</b>
<b>ADJUSTMENT INSTRUCTION .....</b>	<b>7</b>
<b>TROUBLESHOOTING GUIDE .....</b>	<b>12</b>
<b>BLOCK DIAGRAM .....</b>	<b>23</b>
<b>EXPLODED VIEW .....</b>	<b>24</b>
<b>SVC. SHEET .....</b>	

# SAFETY PRECAUTIONS

## IMPORTANT SAFETY NOTICE

Many electrical and mechanical parts in this chassis have special safety-related characteristics. These parts are identified by  $\triangle$  in the Schematic Diagram and Exploded View.

It is essential that these special safety parts should be replaced with the same components as recommended in this manual to prevent X-RADIATION, Shock, Fire, or other Hazards.

Do not modify the original design without permission of manufacturer.

### General Guidance

An **isolation Transformer should always be used** during the servicing of a receiver whose chassis is not isolated from the AC power line. Use a transformer of adequate power rating as this protects the technician from accidents resulting in personal injury from electrical shocks.

It will also protect the receiver and its components from being damaged by accidental shorts of the circuitry that may be inadvertently introduced during the service operation.

If any fuse (or Fusible Resistor) in this monitor is blown, replace it with the specified.

When replacing a high wattage resistor (Oxide Metal Film Resistor, over 1W), keep the resistor 10mm away from PCB.

Keep wires away from high voltage or high temperature parts.

Due to high vacuum and large surface area of picture tube, extreme care should be used in **handling the Picture Tube**. Do not lift the Picture tube by its Neck.

### Leakage Current Cold Check(Antenna Cold Check)

With the instrument AC plug removed from AC source, connect an electrical jumper across the two AC plug prongs. Place the AC switch in the on position, connect one lead of ohm-meter to the AC plug prongs tied together and touch other ohm-meter lead in turn to each exposed metallic parts such as antenna terminals, phone jacks, etc.

If the exposed metallic part has a return path to the chassis, the measured resistance should be between  $1M\Omega$  and  $5.2M\Omega$ .

When the exposed metal has no return path to the chassis the reading must be infinite.

An other abnormality exists that must be corrected before the receiver is returned to the customer.

### Leakage Current Hot Check (See below Figure)

Plug the AC cord directly into the AC outlet.

**Do not use a line Isolation Transformer during this check.**

Connect 1.5K/10watt resistor in parallel with a 0.15uF capacitor between a known good earth ground (Water Pipe, Conduit, etc.) and the exposed metallic parts.

Measure the AC voltage across the resistor using AC voltmeter with 1000 ohms/volt or more sensitivity.

Reverse plug the AC cord into the AC outlet and repeat AC voltage measurements for each exposed metallic part. Any voltage measured must not exceed 0.75 volt RMS which corresponds to 0.5mA.

In case any measurement is out of the limits specified, there is possibility of shock hazard and the set must be checked and repaired before it is returned to the customer.

### Leakage Current Hot Check circuit

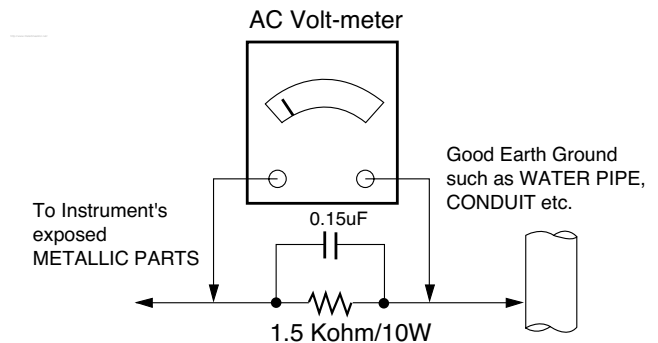

# SPECIFICATIONS

**NOTE :** Specifications and others are subject to change without notice for improvement.

■ **Application Range**

This spec is applied to the PLASMA TV used PD01A Chassis.

■ **Specification**

Each part is tested as below without special appointment.

- 1) Temperature : 25±5°C (77±9°F), CST : 40±5
- 2) Relative Humidity: 65±10%
- 3) Power Voltage: Standard Input voltage (100-240V~, 50/60Hz)  
\* Standard Voltage of each product is marked by models.
- 4) Specification and performance of each parts are followed each drawing and specification by part number in accordance with BOM.
- 5) The receiver must be operated for about 20 minutes prior to the adjustment.

■ **Test Method**

- 1) Performance : LGE TV test method followed.
- 2) Demanded other specification  
Safety : CE, IEC specification  
EMC : CE, IEC

■ **Module Specification**

(1) 42" HD

No	Item	Specification	Remark
1	Display Screen Device	42 inch Wide Color Display Module	PDP
2	Aspect Ratio	16:9	
3	PDP Module	PDP42 T1####, RGB Closed(Well) Type, Glass Filter(38%) Pixel Format: 1365 horiz. By 768 ver.	
4	Operating Environment	1) Temp. : 0 ~ 40deg 2) Humidity : 20 ~ 80%	LGE SPEC.
5	Storage Environment	3) Temp. : -20 ~ 60deg 4) Humidity : 10 ~ 90%	
6	Input Voltage	AC100-240V~, 50/60Hz	Maker LG

## ■ Model General Specification

No	Item	Specification	Remarks
1	Market	Albania, Austria, Belgium, Bosnia, Bulgaria, Coratia, Czech, Denmark, Estonia, Finland, France, Germany, Greece, Hungary, Ireland, Italy, Kazakhstan, Latvia, Lithuania, Luxembourg, Morocco, Netherlands, Norway, Poland, Portugal, Romania, Russia, Serbia, Slovenia, Spain, Sweden, Slovakia, Switzerland, Turkey, Ukraine, UK	36 Country
2	Broadcasting system	1) PAL/SECAM BG 2) PAL/SECAM DK 3) PAL / 4) SECAM L/L' 5) DVB T 6) DVB C	EU (PAL Market)
3	Receiving system	Analog : Upper Heterodyne Digital : COFDM, QAM	
4	Scart Jack (2EA)	PAL, SECAM	Scart 1 Jack is Full scart and support RF-OUT(Analoge) Scart 2 jack is Half scart and support MNT-OUT.
5	Video Input (1EA)	PAL, SECAM, NTSC	Side AV except PJ20, PK20
6	Component Input (1EA)	Y/Cb/Cr, Y/ Pb/Pr	rear
7	RGB Input	RGB-PC	Analog (D-Sub 15Pin) except PJ20, PK20
8	HDMI Input (4EA)	HDMI-PC HDMI-DTV	HDMI1/DVI, HDMI2, HDMI3 1ea : PJ20 2ea : PK30, PK20, PJ60, PJ50, PJ30 3ea : PK50, PK70
9	Audio Input (3 EA)	RGB/DVI Audio, Component, AV	L/R Input
10	SPDIF Out(1 EA)	SPDIF Out	
11	USB	For SVC, S/W Download, X-Studio, DivX	PJ30 doesn't support Divx PK20, PJ20 only for SVC
12	Bluetooth	Bluetooth Phone(JPEG, MP3), Bluetooth Headset(mono, stereo)	Only 50/60PK550 Profile : A2DP, BIP, FTP, GAVDP, HSP, OPP

■ Chroma & Brightness (Optical)

(1) (With 38% Glass Filter) 42T1 module

No	Item		Min	Typ	Max	Unit	Remark
1.	White peak brightness		315		-	cd/m <sup>2</sup>	(*) Peak Brightness Mode -1/100 white Window pattern (Typically 1% Window size) -100IRE (255Gray) -Picture: Vivid (Medium) -Input: HDMI-PC(1920*1080 60Hz) *Peak Brightness Condition may Slightly different between sets.
			148	161			
2.	White average brightness		46	50		cd/m <sup>2</sup>	- 100% Window White Pattern - 100IRE(255Gray) - Picture: Vivid(Medium )
3.	Brightness uniformity		-10	0	+10	%	- 85IRE(216Gray) 100% Window White Pattern - Picture: Vivid(Medium)
4.	Color Coordinate	White	X	0.270	0.285	0.300	- White : 85IRE(216Gray) 100% Window White Pattern - R/G/B : 100IRE(255Gray) 100% Window White Pattern - Picture: Vivid(Medium ) - 100% Window
			Y	0.283	0.293	0.303	
		Red	X	0.635	0.640	-	
			Y	0.318	0.330	0.345	
		Green	X	0.242	0.300	0.305	
			Y	0.595	0.600	-	
		Blue	X	-	0.150	0.158	
			Y	-	0.065	0.075	
5.	Color coordinate uniformity		-0.01	Average	+0.01		- 85IRE 100% Window White Pattern - Picture: Vivid(Medium)
6.	Contrast ratio at dark room		100k: 1	1,000k: 1			-1/100 white window pattern(Peak mode) -100IRE(255Gray) -Picture: Vivid(Medium) -Input: HDMI-PC (1920*1080 60Hz)
7.	Color Temperature	Cool	X	0.261	0.276	0.291	- 85IRE 100% Window White Pattern Warm : ColorGamut => WIDE Cool : Color temperature C30 Meduum : Color temperature 0 Warm : Color temperature W30
			Y	0.268	0.283	0.298	
		Medium	X	0.270	0.285	0.300	
			Y	0.278	0.293	0.308	
		Warm	X	0.298	0.313	0.328	
			Y	0.314	0.329	0.344	

# ADJUSTMENT INSTRUCTION

## 1. Application

This spec. sheet is applied to all of the PD01A chassis.

## 2. Specification

### [Caution: The module keeping condition]

1. The module keeping condition: The normal temperature condition (more than 15°C)  
--> Immediately the line supply.
2. The module keeping condition: 0°C  
--> The module must be kept for more than 2 hours at the normal temperature.
3. The module keeping condition: -20°C  
--> The module must be kept for more than 3 hours at the normal temperature.
4. The case of Gu-mi factory at the winter season.  
--> The module must be kept for more than 5 minutes at the heating zone (40°C~45°C).

- (1) The adjustment is according to the order which is designated and which must be followed, according to the plan which can be changed only on agreeing.
- (2) If there is no specific designation, the adjustment must be performed in the circumstance of 25±5°C of temperature and 65±10% of relative humidity.
- (3) The input voltage of the set must keep 100~240V, 50/60Hz.
- (4) Input signal Unit: Product Specification Standard.
- (5) The set must be operated for about 5 minutes prior to the adjustment.

- After turning on RGB Full Window pattern in HEAT-RUN Mode, the receiver must be operated.
- Enter into HEAT-RUN MODE
  - 1) Press the 'POWER ON' button on R/C for adjustment.
  - 2) Press the 'ADJ' button on R/C and enter EZ ADJUST  
Select "7. Test Pattern" by using ▲/▼ (CH +/-) and press ENTER(■)  
Select "White" by using ◀/▶ (VOL +/-) and press ENTER(■)

- Set heat run should be activated without a signal generator.  
- Single color patterns (RED / BLUE / GREEN) of HEAT RUN MODE are used to check a plasma panel.

- Caution: If you turn on a still screen more than 20 minutes (Especially digital pattern, cross hatch pattern), an after image may be made in the black level part of the screen.

### [Caution]

- Use 'power on' button of a service R/C to power on TV set.
- Do not connect any external input cable if there is no any specifics.

## 3. Update S/W using Auto Download through the USB

Caution: S/W version of USB file (xxx.epk) must be bigger than one which is downloaded previously.

- (1) Insert the USB stick to the USB socket
- (2) A downloaded file in USB stick will be detected automatically.
- (3) If S/W version of USB file (xxx.epk) is bigger than one which is downloaded previously, the message, "Copying files from memory", will appear.
- (4) If an update procedure was completed, TV set will be turned off and on automatically.
- (5) If TV set is turned on, check an updated version.  
\* If a downloaded version is more bigger than one of which TV set had, TV set can lost channel data. In this case, you have to scan channels again.

## 4. After Downloading S/W, Adjust TOOL OPTION

- (1) Push "IN-START" button on a service R/C.
- (2) Select "Tool Option 1" and Push "OK" button.
- (3) Put the number of a below table in order of a suffix of the "Tool Option(X)".  
(Each model has a different number.)

Model	Tool Option1	Tool Option2	Tool Option3	Tool Option4
42PJ250-ZC	25088	546	2252	3360
42PJ350-ZA	25024	1574	35020	3360
42PJ550-ZD	24960	1574	51404	3360
42PJ650-ZA	24896	1574	51408	3360
50PJ250-ZC	37376	546	2252	3360
50PJ350-ZA	37312	1574	35020	3360
50PJ550-ZD	37248	1574	51404	3360
50PJ650-ZA	37184	1574	51408	3360
50PK250-ZA	37120	1570	2252	3360
50PK350-ZB	37056	1574	51404	3360
50PK550-ZE	36992	2598	55500	11552
50PK750-ZA	36928	2598	51408	11552
60PK250-ZA	49408	1570	2252	3360
60PK550-ZE	49280	2598	55500	11552

## 5. ADC Calibration Procedure

- (1) Input the component (480i/Horizontal Color Bar) signal to a TV set.
  - 1) Input Signal Timing : Component 480i  
(Other external connection is unnecessary except the component before executing ADC calibration.)
  - 2) Input Signal Pattern

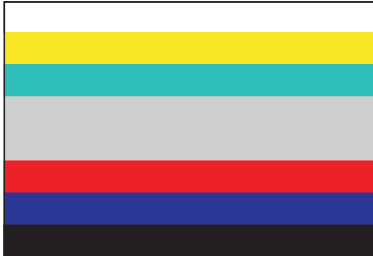

<Horizontal Color Bar pattern>

@ MODEL: 209 in Pattern Generator(480i Mode)  
 @ PATTERN : 65 in Pattern Generator(MSPG-925 SERISE)

- (2) Push "ADJ" button on a service R/C.
- (3) Enter internal ADC mode by selecting '5. ADC Calibration'.
- (4) If you select 'Start' on a dialog box of the screen, ADC calibration will be begun.

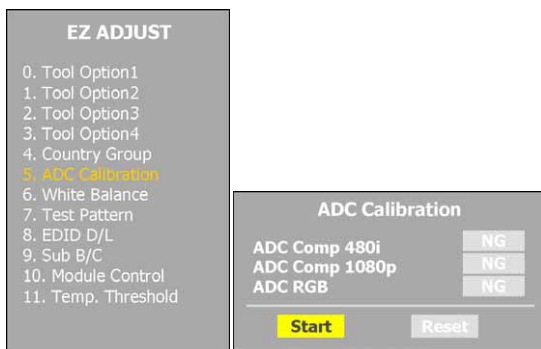

Caution: Don't connect any external input cable except the component input(480i/Horizontal\_Color\_Bar) to adjust ADC calibration

### ● Auto ADC Calibration Map(RS-232C)

NO	Item	CMD1	CMD2	Data0	
Enter Adjust MODE	Adjust 'Mode In'	A	A	0 0	When transfer the 'Made In', Carry the command.
ADC Adjust	ADC Adjust	A	D	1 0	Automatically adjustment (The use of a internal pattern)

### # Adjust Sequence

- aa 00 00 [Enter Adjust Mode]
- xb 00 40 [Component1 Input (480i)]
- ad 00 10 [Adjust 480i Comp1]
- xb 00 60 [RGB Input (1024\*768)]
- ad 00 10 [Adjust 1024\*768 RGB]
- aa 00 90 End Adjust mode

## 6. EDID Download Procedure

- (1) Push "ADJ" button on a service R/C.
- (2) Enter EDID auto download mode by selecting '8. EDID D/L'.

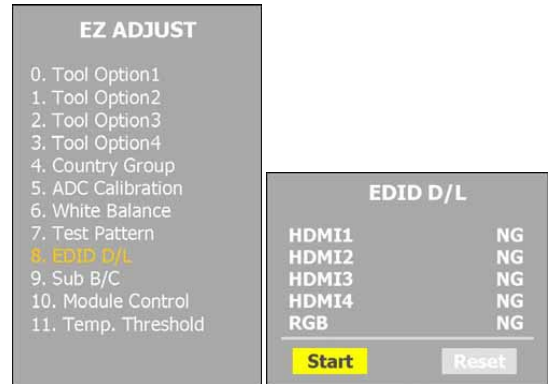

- (3) If you select 'Start' on a dialog box of the screen, EDID download will be begun automatically.
- (4) Press 'EXIT' button on a service R/C.
- (5) EDID Data

### 1) HDMI (HD Models, 256 bytes)

	00	01	02	03	04	05	06	07	08	09	0A	0B	0C	0D	0E	0F
00	00	FF	FF	FF	FF	FF	FF	00	1E	6D	ⓐ			ⓑ		
10	Ⓐ	ⓐ	01	03	80	46	27	78	0A	D9	B0	A3	57	49	9C	25
20	11	49	4B	A1	08	00	31	40	45	40	61	40	D1	C0	01	01
30	01	01	01	01	01	01	1B	21	50	A0	51	00	1E	30	48	88
40	35	00	BC	86	21	00	00	1C	1A	36	80	A0	70	38	1F	40
50	30	20	35	00	E8	26	32	00	00	1A	00	00	00	FD	00	38
60	3E	1C	53	12	00	0A	20	20	20	20	20	20		Ⓒ		
70	Ⓓ														01	ⓓ

	00	01	02	03	04	05	06	07	08	09	0A	0B	0C	0D	0E	0F
00	02	03	29	F1	51	81	02	03	06	07	15	16	11	12	13	04
10	14	05	20	22	1F	10	26	15	07	50	09	7F	07	67	03	0C
20	00	Ⓐ	00	B8	2D	E3	05	03	01	01	1D	00	80	51	D0	1C
30	20	40	80	35	00	BC	88	21	00	00	1E	4E	1F	00	80	51
40	00	1E	30	40	80	37	00	BC	88	21	00	00	18	02	3A	80
50	18	71	38	2D	40	58	2C	45	00	06	44	21	00	00	1E	01
60	1D	80	18	71	1C	16	20	58	2C	25	00	C4	8E	21	00	00
70	9E	00	00	00	00	00	00	00	00	00	00	00	00	00	00	ⓔ

### 2) RGB (HD Models, 128 bytes)

	00	01	02	03	04	05	06	07	08	09	0A	0B	0C	0D	0E	0F
00	00	FF	FF	FF	FF	FF	FF	00	1E	6D	ⓐ			ⓑ		
10	Ⓐ	ⓐ	01	03	01	46	27	78	0A	D9	B0	A3	57	49	9C	25
20	11	49	4B	A1	08	00	31	40	45	40	61	40	D1	C0	01	01
30	01	01	01	01	01	01	1B	21	50	A0	51	00	1E	30	48	88
40	35	00	BC	86	21	00	00	1C	1A	36	80	A0	70	38	1F	40
50	30	20	35	00	E8	26	32	00	00	1A	00	00	00	FD	00	38
60	3E	1C	53	12	00	0A	20	20	20	20	20	20		Ⓒ		
70	Ⓓ														00	ⓓ

### ● EDID Data detailing ( , , , , , )



Product ID

MODEL	EDID MODEL	PRODUCT_ID	FUNCTION
ALL Model	LG DTV	0001(0x01, 0x00)	Analog
ALL Model	LG DTV	0001(0x01, 0x00)	Digital

Serial No

=> Controlled on production line

Month, Year

=> Controlled on production line:

MODEL NAME	MODEL NAME (HEX)
LG TV	0x4C, 0x47, 0x20, 0x54, 0x56

Model Name

Checksum

=> Changeable by total EDID data

	FHD		HD	
HDMI1	0xE2	0xB4	0xAF	0xB4
HDMI2	0xE2	0xA4	0xAF	0xA4
HDMI3	0xE2	0x94	0xAF	0x94
HDMI4	-	-	-	-
RGB	0x62		0x2F	

HDMI Port No.

● Auto EDID Download Map(RS-232C)

NO	Item	CMD1	CMD2	Data0	
Enter download MODE	Download 'Mode In'	A	A	0 0	When transfer the 'Made In', Carry the command.
EDID data and Model option download	Download	A	E	00 10	Automatically download (The use of a internal Data)

## 7. PCMCIA CARD Check

You must adjust DTV 29 Channel and insert PCMCIA CARD to socket.

- If PCMCIA CARD works normally, video signals will appear on screen.

But it works abnormally, "No CA module" will appear on screen.

\* Caution: Set up "RF mode" before launching products.

## 8. POWER Supply Unit PCB Ass'y Va/Vs Voltage Adjustment

Caution: Both Vs and Va voltage adjustment are necessary.

### 8-1. Model name:

42PJ250-ZC, 42PJ350-ZA, 42PJ550-ZD, 42PJ650-ZA  
 50PJ250-ZC, 50PJ350-ZA, 50PJ550-ZD, 50PJ650-ZA  
 50PK250-ZA, 50PK350-ZB, 50PK550-ZE, 50PK750-ZA  
 60PK250-ZA, 60PK550-ZE

### 8-2. Va/Vs Adjustment Procedure

- (1) Connect positive(+) terminal of DMM to Vs/Va pin, connect negative(-) terminal to GND.
- (2) Turning 'Vs/Va Adjust' and adjust Vs/Va voltages to a value which is written on a right/top label of a module. (deviation ; ±0.5V)

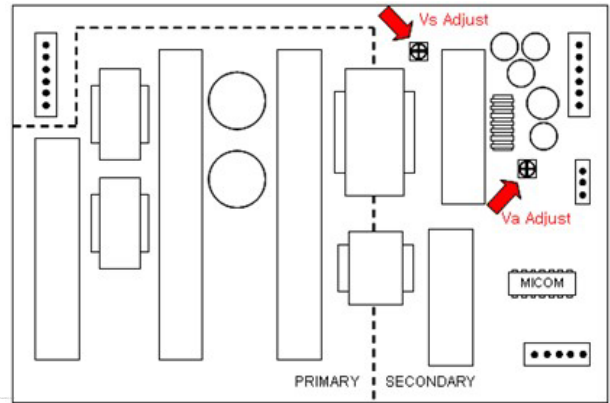

[Caution]

- Each Power Supply Unit PCB assembly must be checked by check JIG set. (Because power PCB Ass'y damages to PDP Module, especially be careful)
- Set up "RF mode(noise)" before a voltage adjustment.
- Test equipment: DMM 1EA

## 9. White Balance Adjustment

Caution: Press the POWER ON KEY on R/C before W/B adjustment.

- Test Equipment  
Color Analyzer (CS-1000, CA-100+(CH.10), CA-210(CH.10))
- Please adjust CA-100+ / CA-210 by CS-1000 before measuring  
You should use Channel 10 which is Matrix compensated (White, Red, Green, Blue revised) by CS-1000 and adjust in accordance with White balance adjustment coordinate.

### 9-1. Color Temperature Standards According to CSM and Module(TBD)

CSM	PLASMA
Cool	11000K
Medium	9300K
Warm	6500K

### 9-2. Change Target Luminance and Range of the Auto Adjustment W/B Equipment

- 42PJ250-ZC(42T1), 42PJ350-ZA(42T1), 42PJ550-ZD(42T1), 42PJ650-ZA(42T1),
- 50PJ250-ZC(50T1), 50PJ350-ZA(50T1), 50PJ550-ZD(50T1), 50PJ650-ZA(50T1)
- 50PK250-ZA(50R1), 50PK350-ZB(50R1), 50PK550-ZE(50R1), 50PK750-ZA(50R1)
- 60PK250-ZA(60R1), 60PK550-ZE(60R1)

Target luminance	50
Range	20

### 9-3. White Balance Adjustment Coordinate and Color Temperature

Cool	CS-1000	CA-100+ (CH.10)	CA-210 (CH.10)
x	0.276	0.276±0.002	0.276±0.002
y	0.283	0.283±0.002	0.283±0.002
Δuv	0.000	0.000	0.000
Medium	CS-1000	CA-100+ (CH.10)	CA-210 (CH.10)
x	0.285	0.285±0.002	0.285±0.002
y	0.293	0.293±0.002	0.293±0.002
Δuv	0.000	0.000	0.000
Warm	CS-1000	CA-100+ (CH.10)	CA-210 (CH.10)
x	0.313	0.313±0.002	0.313±0.002
y	0.329	0.329±0.002	0.329±0.002
Δuv	0.003	0.003	0.003

\* PC (for communication through RS-232C) ? UART Baud rate : 115200 bps

### 9-4. Automatic W/B Adjustment

- (1) Internal PATTERN should be used when W/B is adjusted. Connect to auto controller like below.

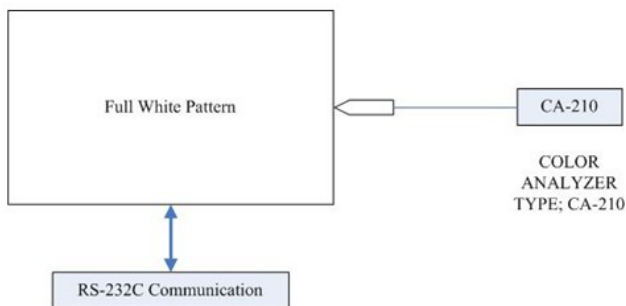

- (2) Start White-Balance adjustment, then the full white window pattern will appear on the screen.
- (3) Adjust in the place where the influx of light like floodlight around is blocked. (illumination is less than 10ux).
- (4) Measure and adjust after sticking the Color Analyzer (CA-100+, CA210 ) to the side of the module.

#### ● Auto W/B Adjustment Map(RS-232C)

RS-232C COMMAND

[ CMD ID DATA ]

Wb 00 00 White Balance Start  
Wb 00 FF White Balance End

	RS-232C COMMAND [CMD ID DATA]			Min	CENTER (DEFAULT)			MAX
	Cool	Med	Warm		Cool	Med	Warm	
R Gain	00	00	00	00	192	192	192	255
G Gain	00	00	00	00	192	192	192	255
B Gain	00	00	00	00	192	192	192	255
50H3 60H3	R Cut				64	64	64	128
	G Cut				64	64	64	128
	B Cut				64	64	64	128

### 9-5. Manual W/B Adjustment

- (1) Execute the zero calibration of CA-100+ / CA-210.
- (2) Press the 'ADJ' button on a service R/C and enter EZ ASJUST by selecting '6. White Balance'.
- (3) Then, 216 gray pattern will appear on the screen.
- (4) Change the R/G/B-Gain as passing in 3 color coordinates and temperatures, COOL, MEDIUM and WARM.

< Temperature: COOL >

- R-Cut / G-Cut / B-Cut is set to 64
- Control R-Gain and G-Gain.
- Each gain is limited to 192

< Temperature: MEDIUM >

- R-Cut / G-Cut / B-Cut is set to 64
- Control R-Gain and G-Gain.
- Each gain is limited to 192

< Temperature: WARM >

- R-Cut / G-Cut / B-Cut is set to 64
- Control G-Gain and B-Gain.
- Each gain is limited to 192

- (5) Press 'EXIT' button on a service R/C

**EZ ADJUST**

0. Tool Option1
1. Tool Option2
2. Tool Option3
3. Tool Option4
4. Country Group
5. ADC Calibration
6. White Balance
7. Test Pattern
8. EDID D/L
9. Sub B/C
10. Module Control
11. Temp. Threshold

**White Balance**

Color Temp. < Cool >

R-Gain 172

G-Gain 172

B-Gain 192

R-Cut 64

G-Cut 64

B-Cut 64

Test-Pattern. ON

Reset To Set

**<Notice> Module Heat-Run Condition for W/B**

1. The adjustment must be performed in the circumstance of 25±5°C of temperature and 65±10% of relative humidity if there is no any specifics.
2. Before an W/B adjustment, the module which will be used should be placed in the circumstance of 15°C~25°C for above 2 hours.
3. If a module was placed in the circumstance of below 15°C, it should be placed in the circumstance of 15°C~25°C for above 2 hours or be run for above 5 minutes in an aging environment of 60°C.
4. Before an W/B adjustment, TV set should be run for 5 minutes at least.

## 10. Serial Number Download

### 10-1. Download Procedure

- (1) Press "Power on" button of a service R/C.(Baud rate : 115200 bps)
- (2) Connect RS232-C Signal Cable.
- (3) Write Serial number through RS-232C.
- (4) Check the serial number at the Diagnostics of 'SETUP' menu. (Refer to below).

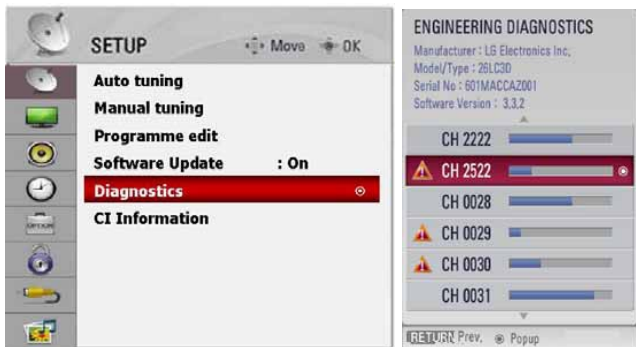

Caution : Don't download HDMI/RGB EEPROM to write a model name. Model name does unnecessary because this model use 'Tool Option' to call a model name.

### 10-2. Signal TABLE

CMD	LENGTH	ADH	ADL	DATA_1	...	Data_n	CS	DELAY
-----	--------	-----	-----	--------	-----	--------	----	-------

- CMD : A0h
- LENGTH : 85~94h (1~16 bytes)
- ADH : EEPROM Sub Address high (00~1F)
- ADL : EEPROM Sub Address low (00~FF)
- Data : Write data
- CS : CMD + LENGTH + ADH + ADL + Data\_1 + ... + Data\_n
- Delay : 20ms

## 10-3. Command Set

No.	Adjust mode	CMD(hex)	LENGTH(hex)	Description
1	EEPROM WRITE	A0h	84h+n	n-bytes Write (n = 1~16)

[Description]

FOS Default write : <7mode data> write  
 Vtotal, V\_Frequency, Sync\_Polarity, Htotal, Hstart, Vstart, 0, Phase  
 Data write : Model Name and Serial Number write in EEPROM,.

## 11. CI+ Key Download

### 11-1. Download Procedure

1. Press "Power on" button of a service R/C.(Baud rate : 115200 bps)
2. Connect RS232-C Signal Cable.
3. Write CI+ Key through RS-232C.
4. Check whether the key was downloaded or not at 'In Start' menu. (Refer to below)

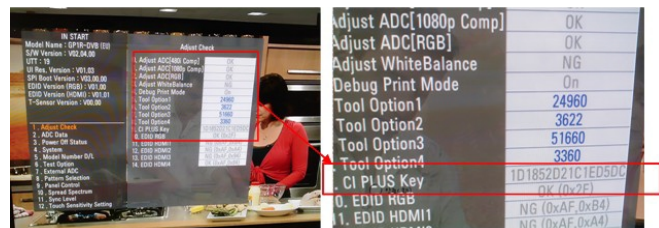

## 12. Check Information (Serial No. & Model name)

- (1) Push the menu button in DTV mode.
- (2) Select the SETUP -> Diagnostics -> To set
- (3) Check the Serial Number





2). Input/Output pin assignment

### AC Inlet

	SC101
1	AC(N)
2	NC
3	AC(L)
Wafer	SMW-600-03B1

### PSU ↔ PDP Module

Pin	50FHID	
	P811	P812
1	Vs	Vs
2	Vs	Vs
3	NC	NC
4	GND	GND
5	GND	GND
6	Va	Va
7	Va	Va
8	GND	GND
9	M5V	M5V
10	M5V	M5V

### PSU ↔ VSC Board

P814		
1	17V	2
3	GND	4
5	5V	6
7	5V	8
9	GND	10
11	GND	12
13	STBY	14
15	AC DET	16
17	AUTO_GND	18
		17V
		GND
		5V
		5V
		GND
		GND
		STBY
		RL-ON
		M_ON

## 2. No Power

- Symptom

- 1) Doesn't minute discharge at module.
- 2) Non does not come in into the front LED.

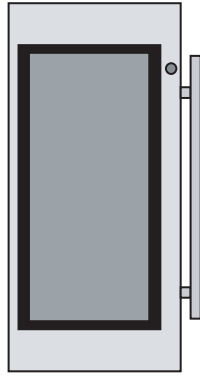

- Check the followings

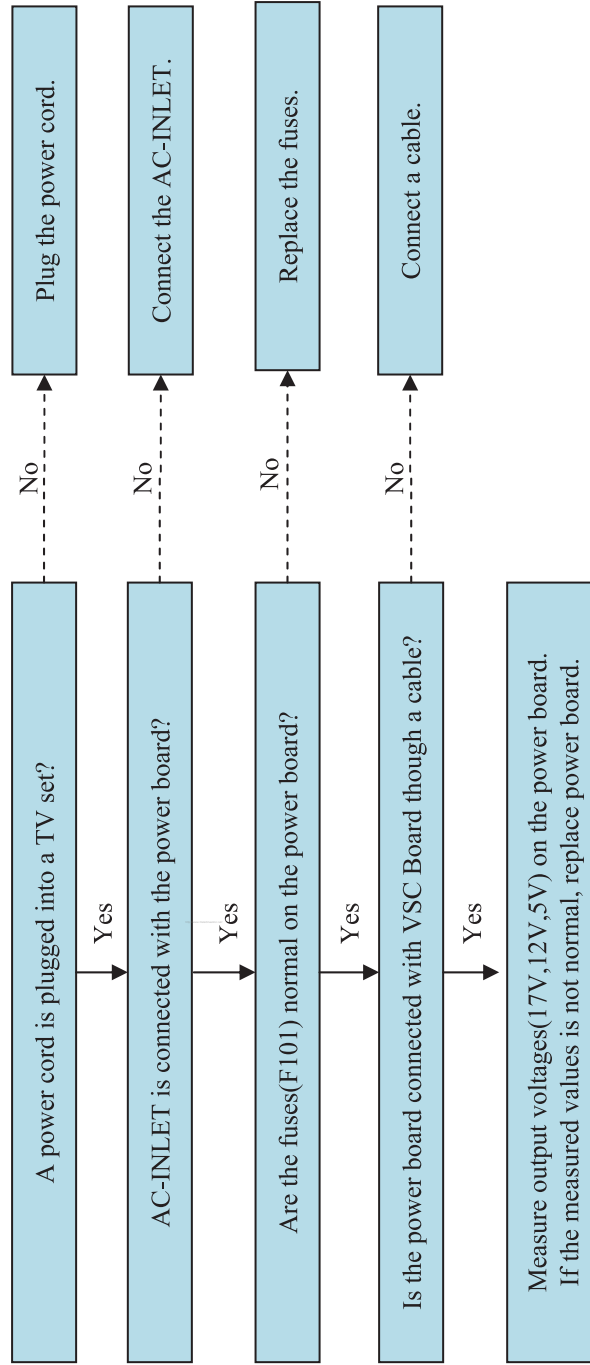

### 3. Protect Mode

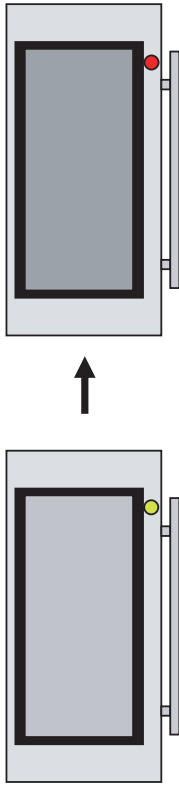

- **Symptom**

- 1) After once shining, it does not discharge minutely from module.
- 2) The Rely falls(The sound is audible "click")
- 3) If you push key on remote controller or local key, the front LED is blinking with white.

- **Check the followings**

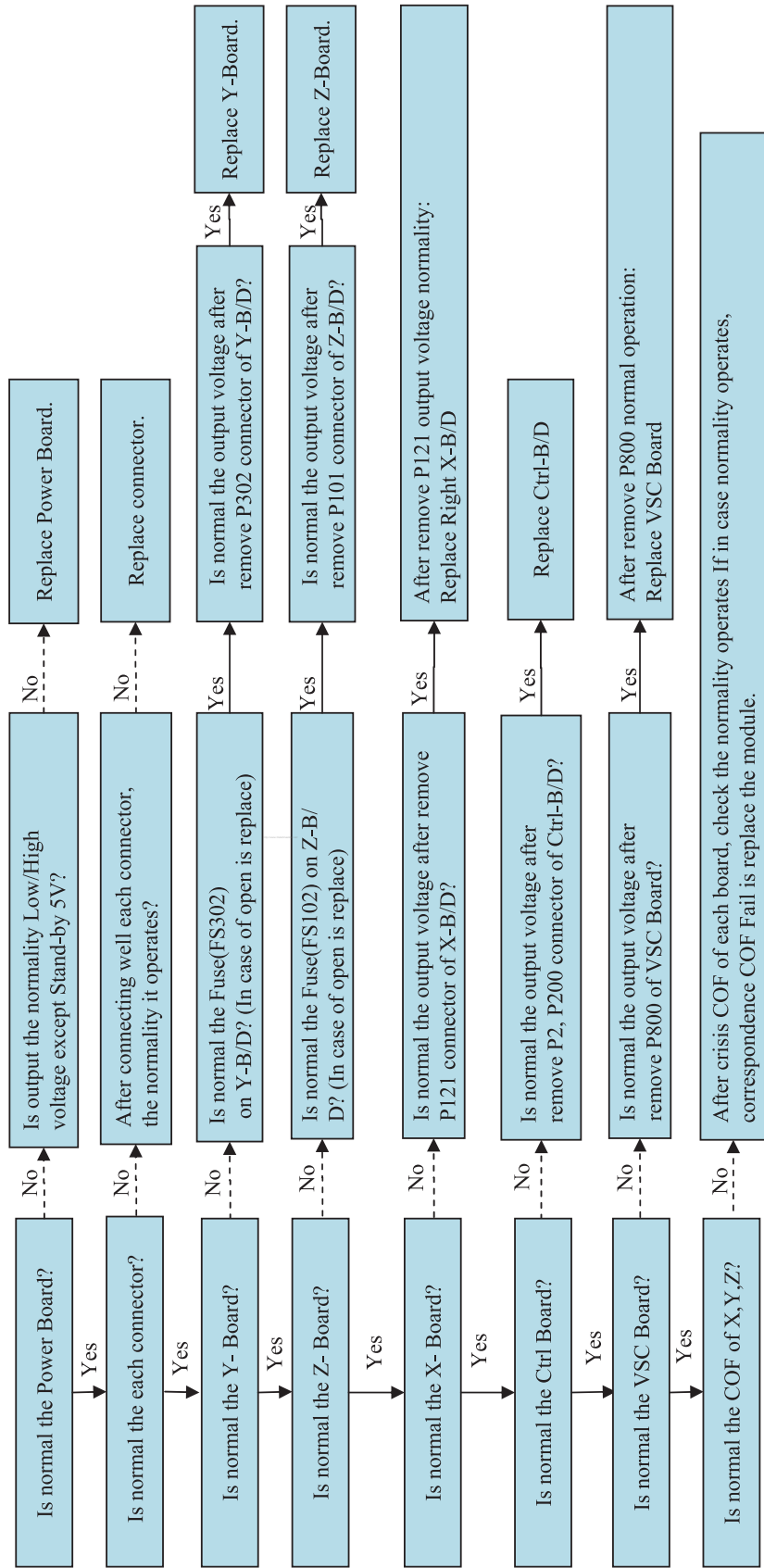



## 4. No Raster

- Symptom

- 1) No OSD and image occur at screen.
- 2) If you push key on remote controller or local key, the front LED is blinking with white.

- Check the followings

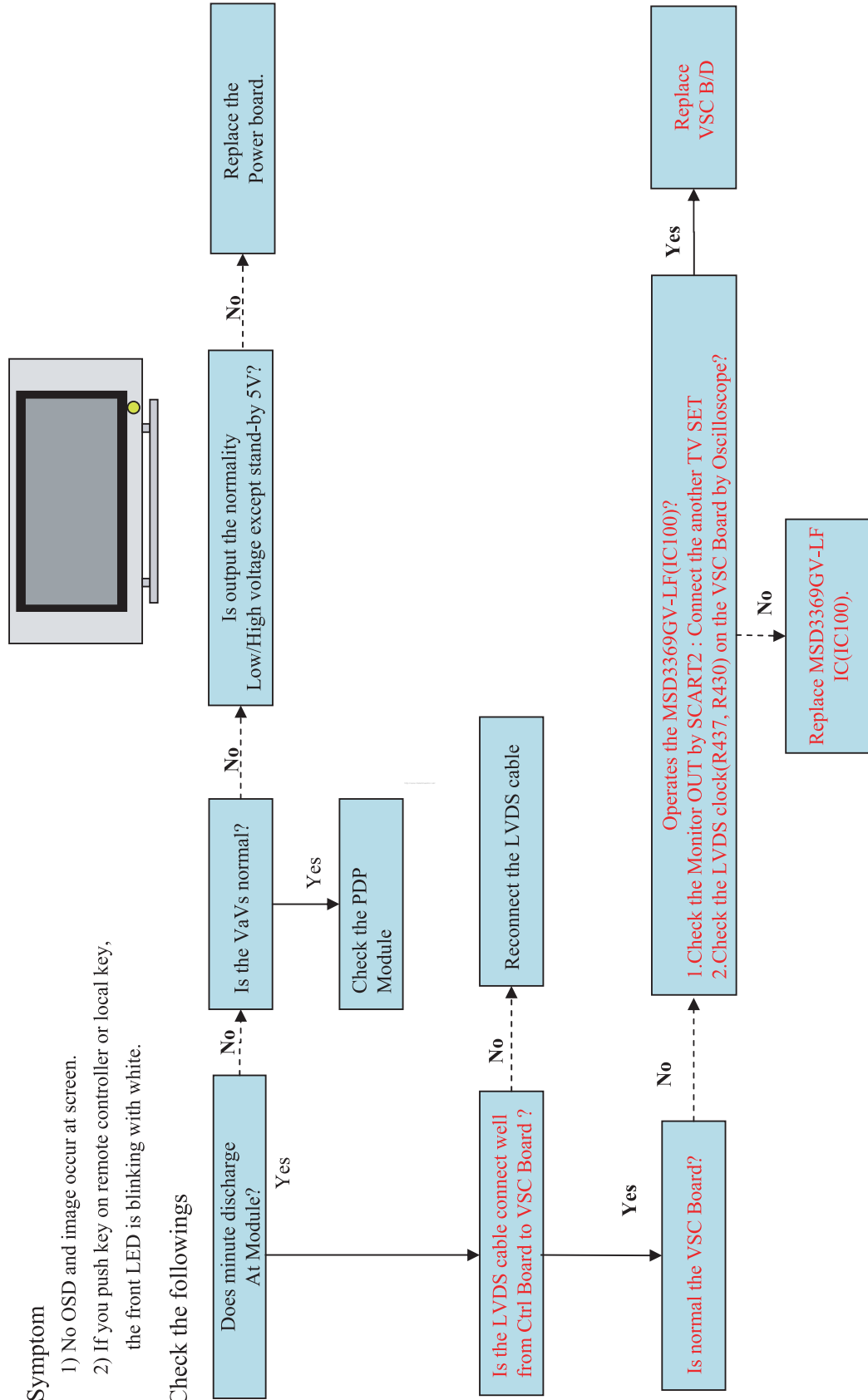

## 5. In case of occur strange screen into specific mode

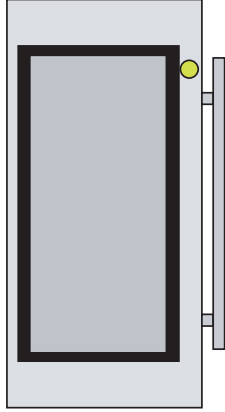

### 1) In case of doest display the OSD

- Symptom

- 1) If you push key on remote controller or local key, the front LED is blinking with white.
- 2) The minute discharge continuously becomes accomplished from module

- Check the followings

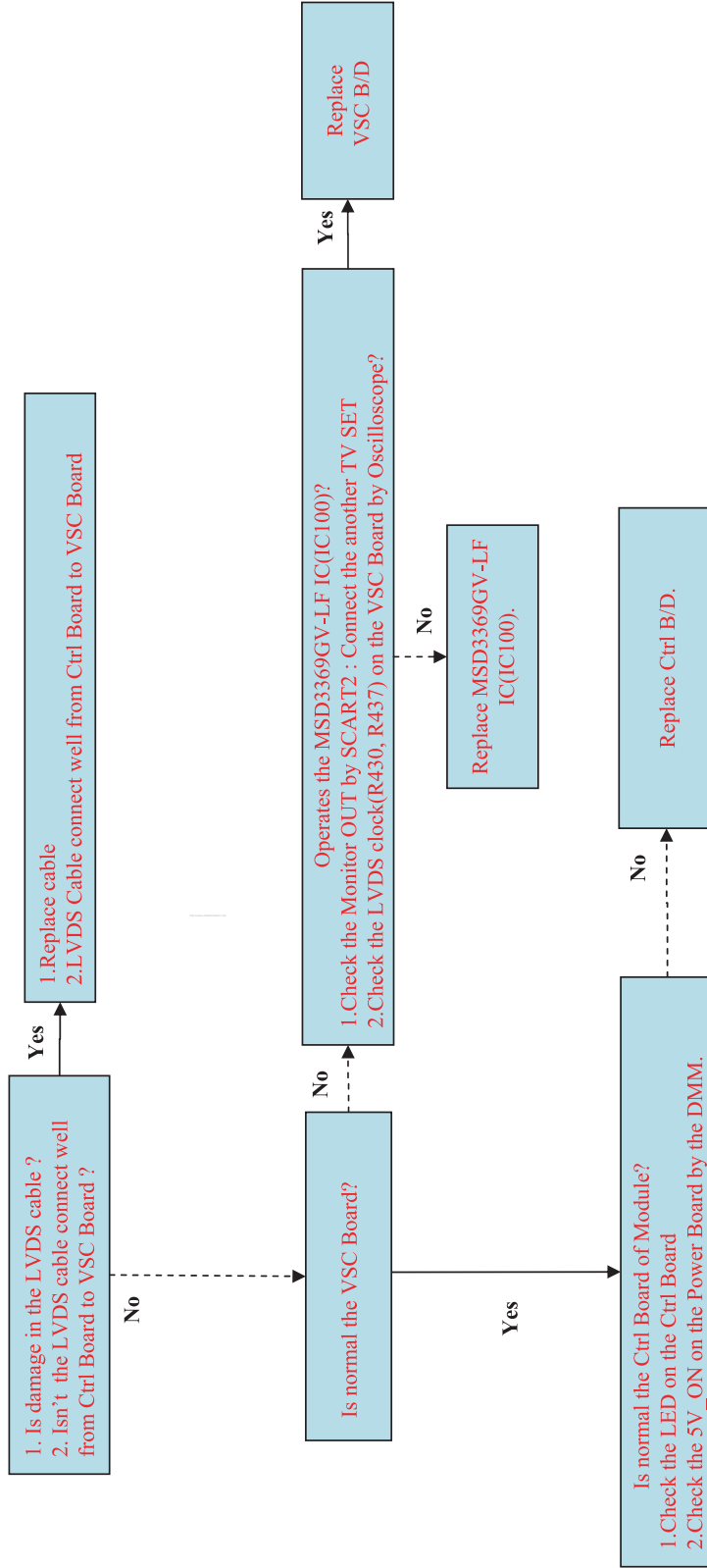

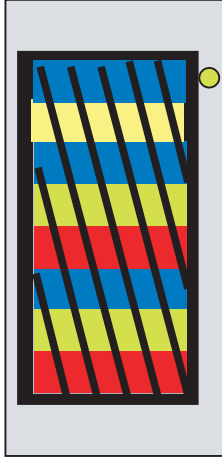

## 2) In case of doesn't display the screen into specific mode

- Symptom
  - 1) The screen does not become the display from specific input mode (RF, AV, Component, RGB, DVI/HDMI).
- Check the followings
  - 1) Check the all input mode should become normality display.
- In case of unusual display for **RF mode**.

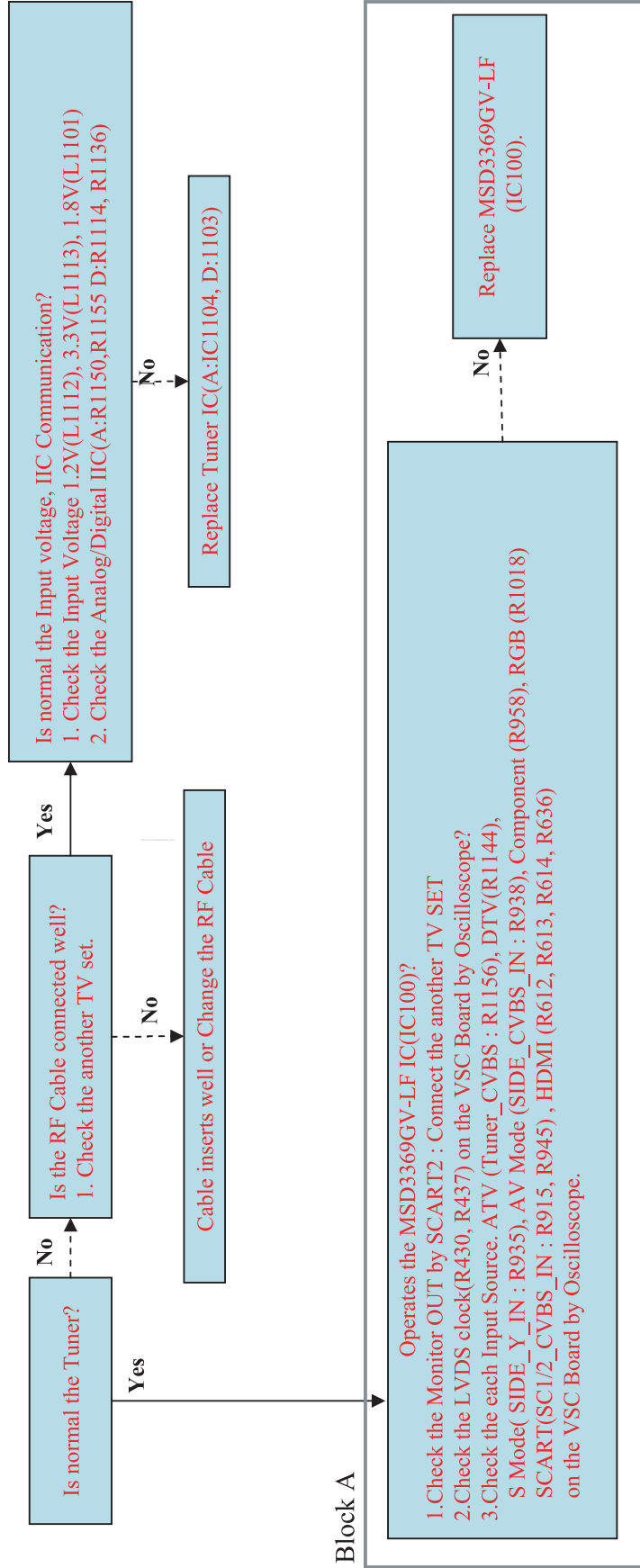

● In the case of unusual display for side **S-video / AV mode**.

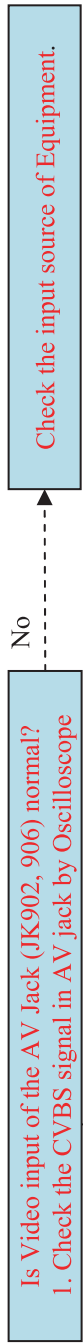

● In the case of unusual display for **Component, RGB mode**.



● In the case of unusual display for **HDMI mode**.

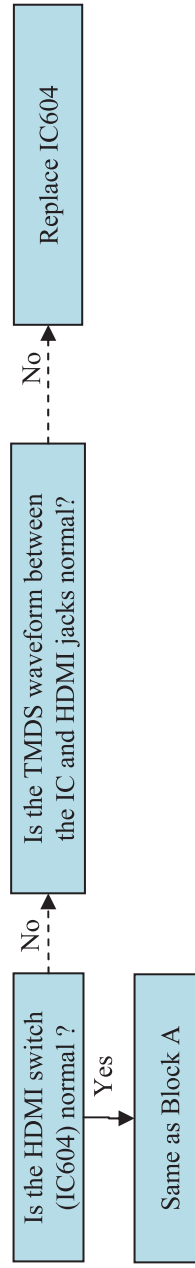

● In the case of unusual display for **SCART mode**.

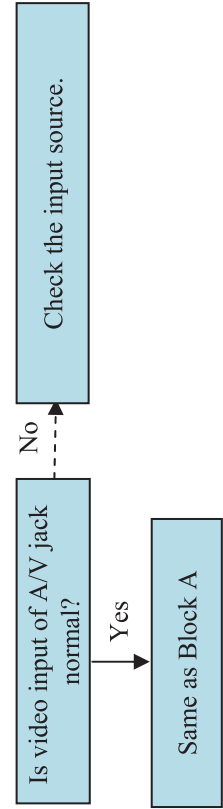

## 6. In case of no sound

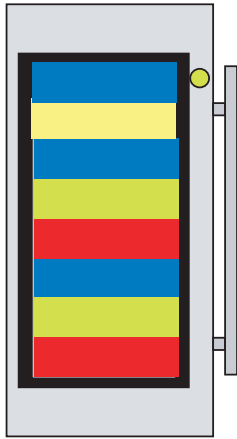

- Symptom  
1) Screen display but sound is not output
- Check follow

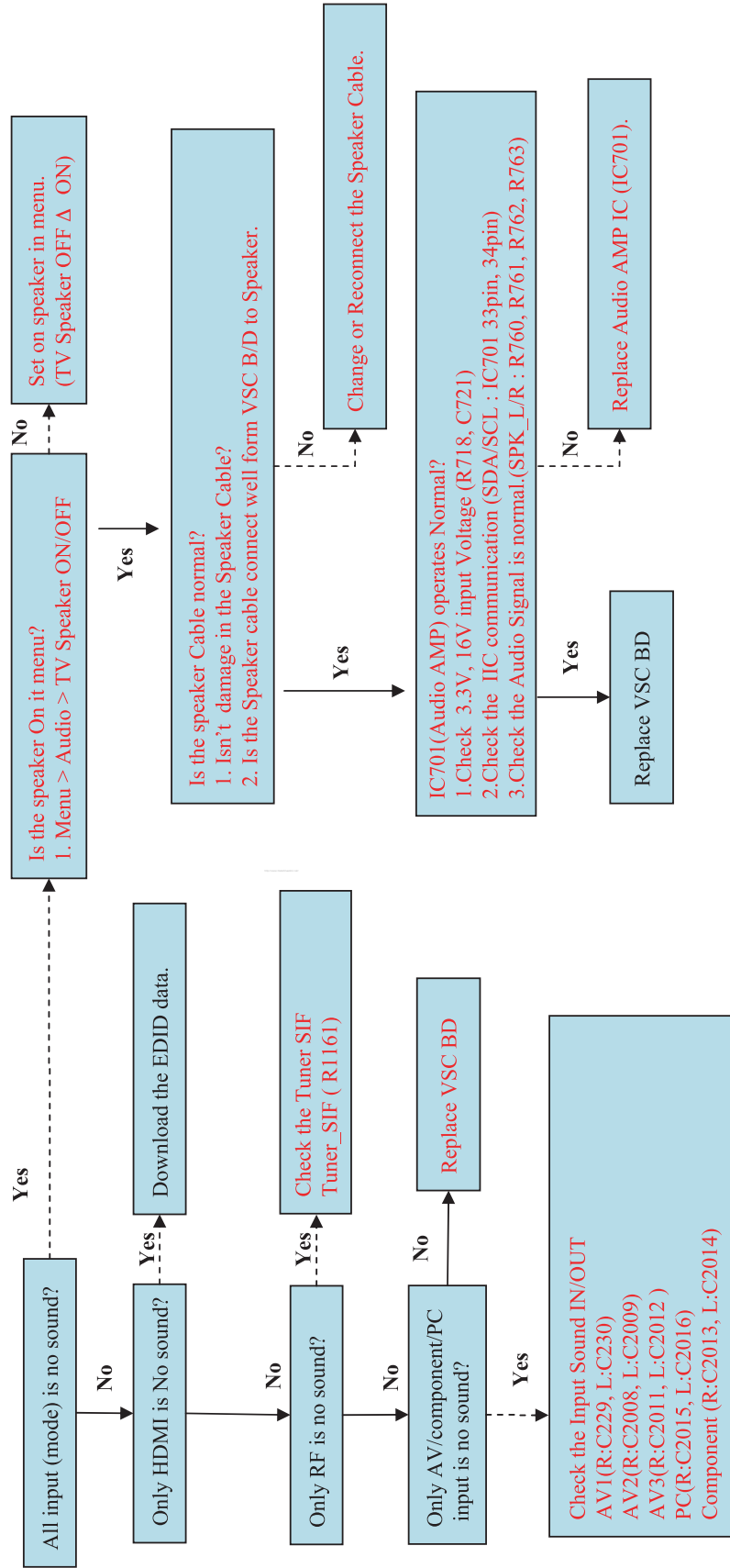

## 7. In case of no tuning

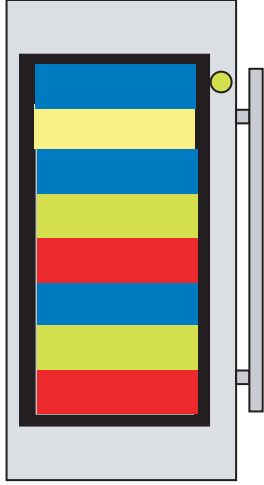

- Symptom

- 1) Not working remote control.
- 2) Not working local Key.

- Check follow(1)

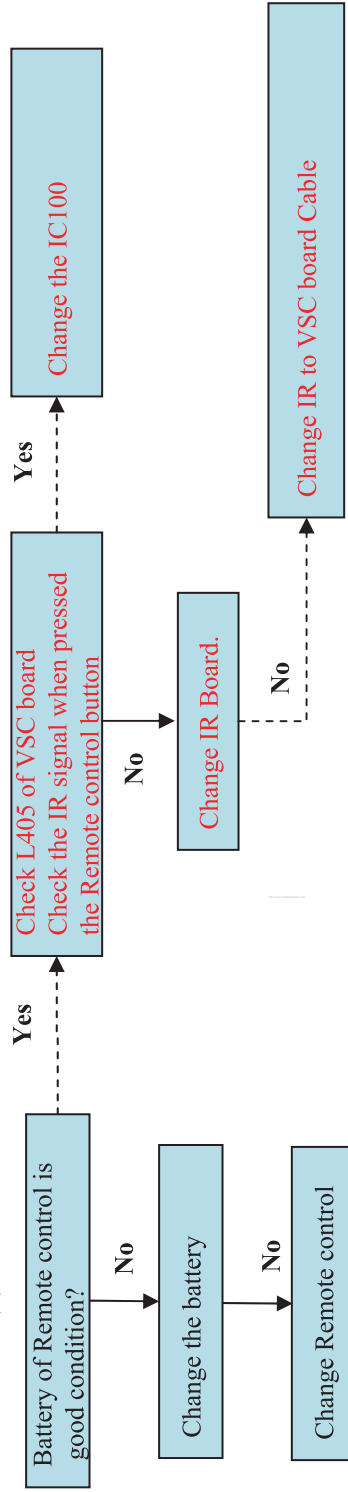

- Check follow(2)

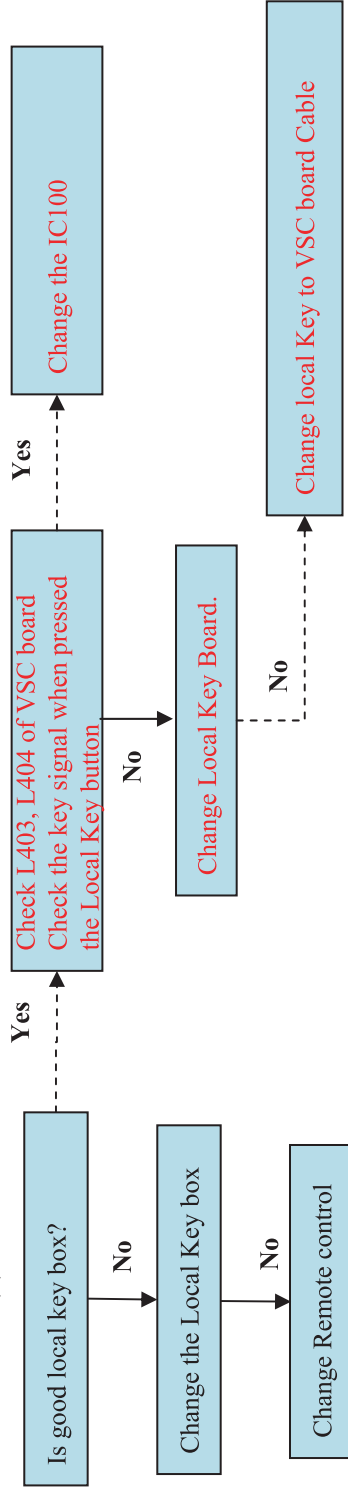

# BLOCK DIAGRAM

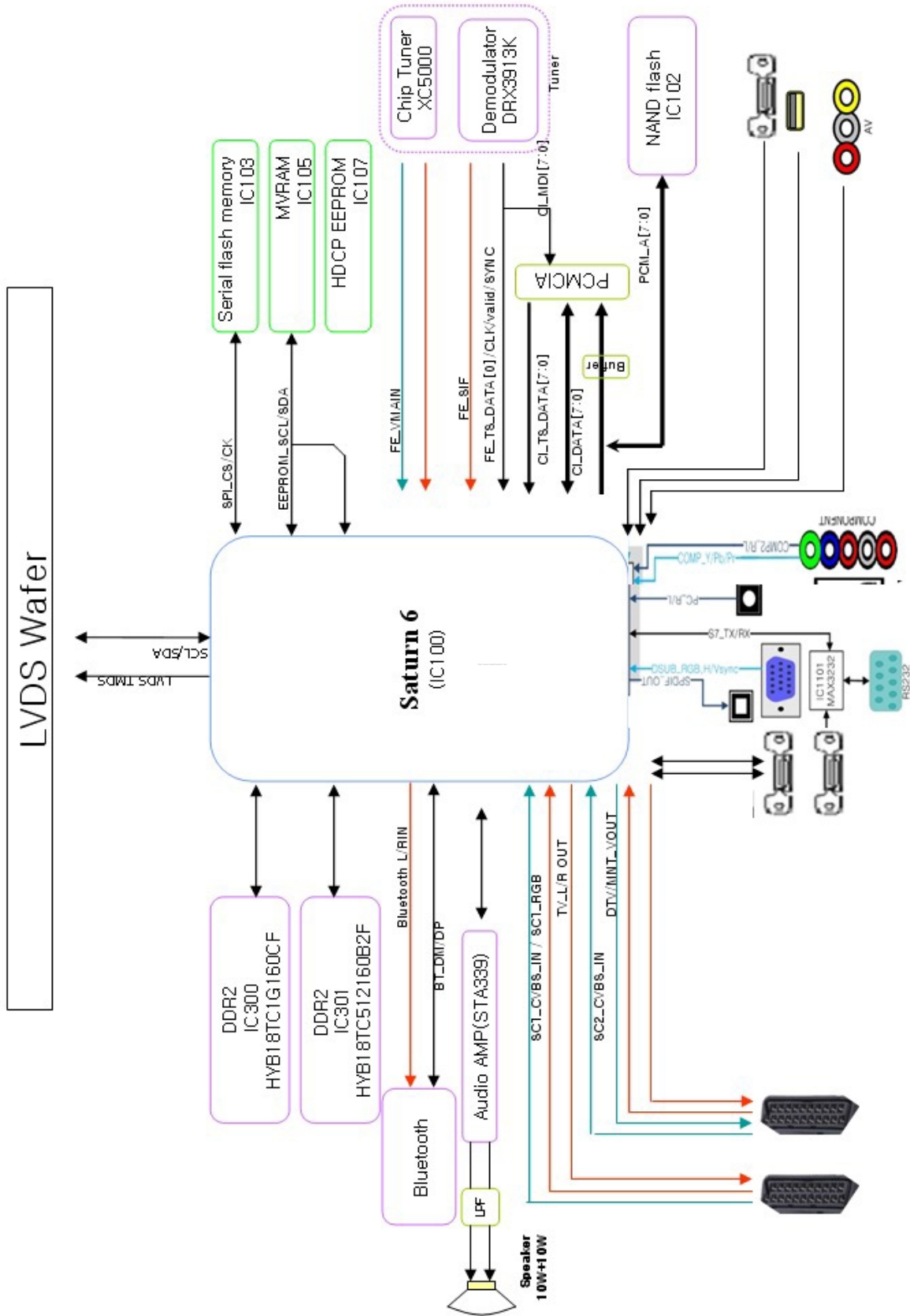

# EXPLODED VIEW

## IMPORTANT SAFETY NOTICE

Many electrical and mechanical parts in this chassis have special safety-related characteristics. These parts are identified by  $\Delta$  in the Schematic Diagram and EXPLODED VIEW. It is essential that these special safety parts should be replaced with the same components as recommended in this manual to prevent X-RADIATION, Shock, Fire, or other Hazards. Do not modify the original design without permission of manufacturer.

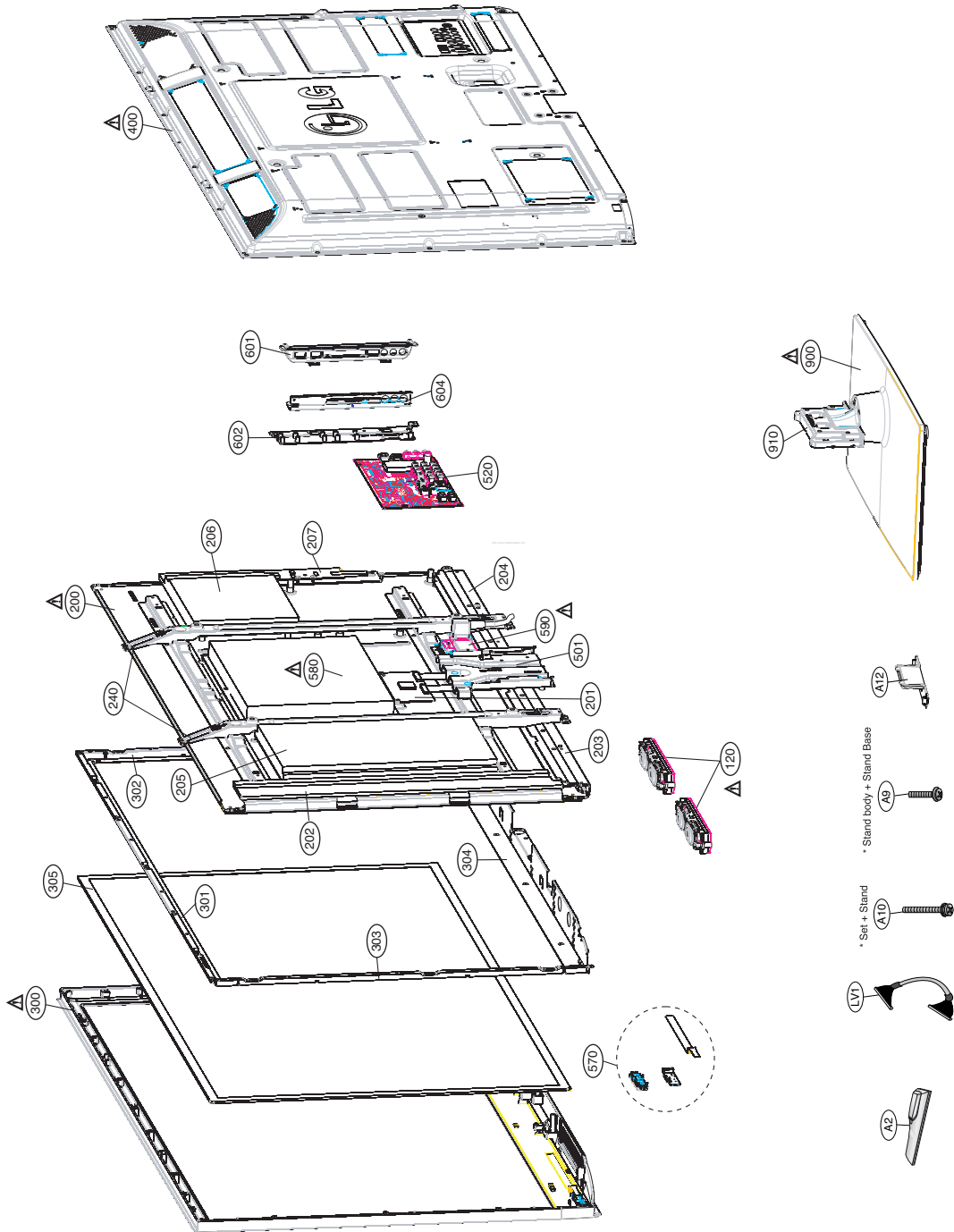



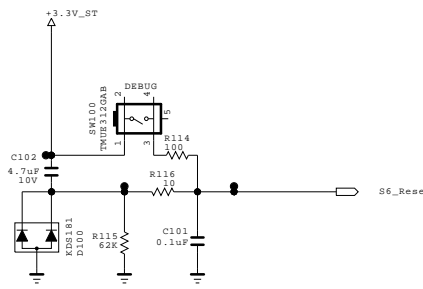
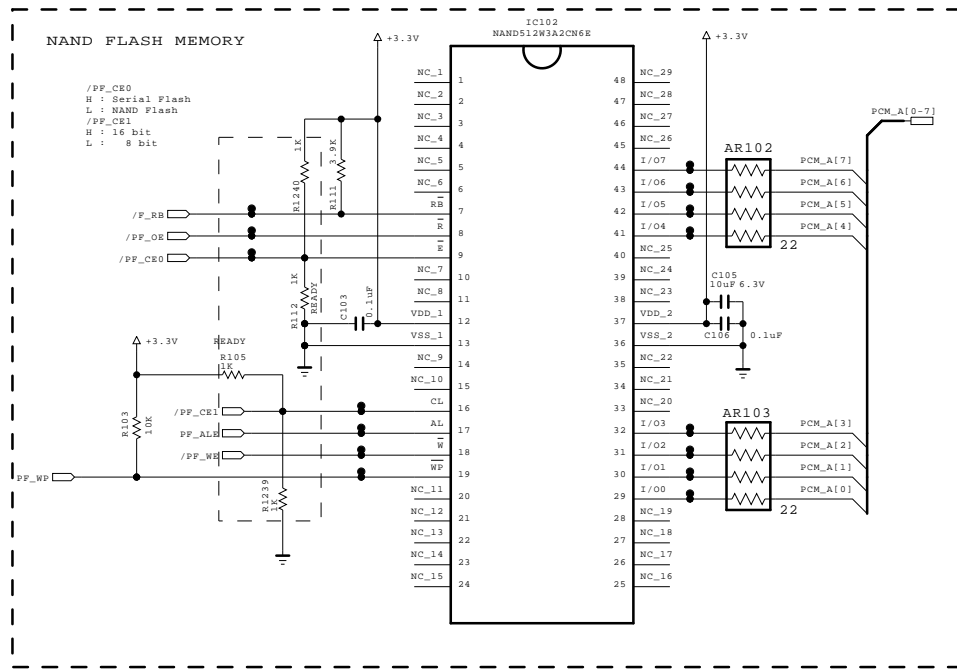

**IC100  
LGE3369A (Saturn6 Non RM)**

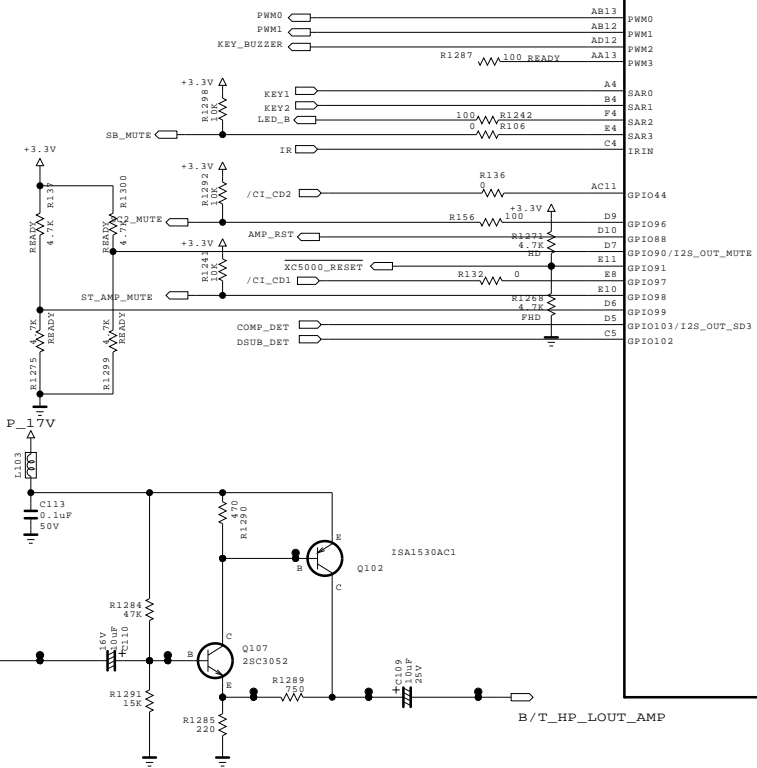
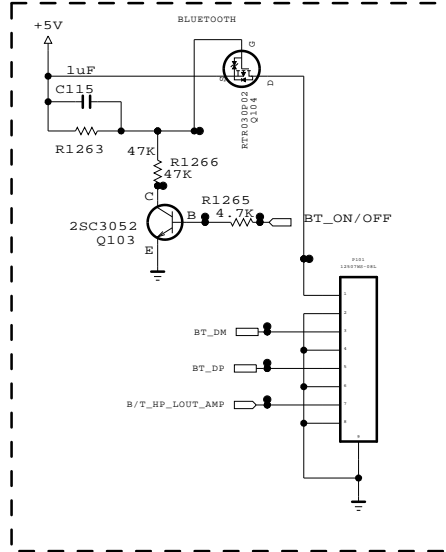
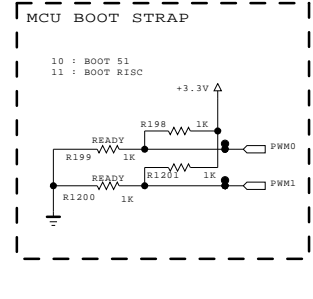
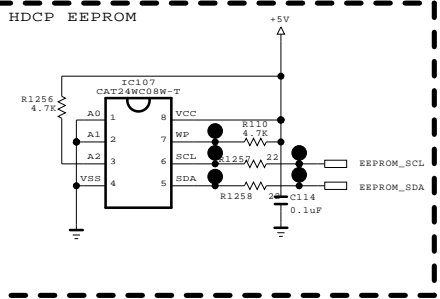
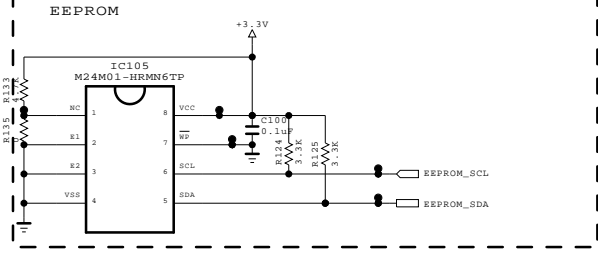
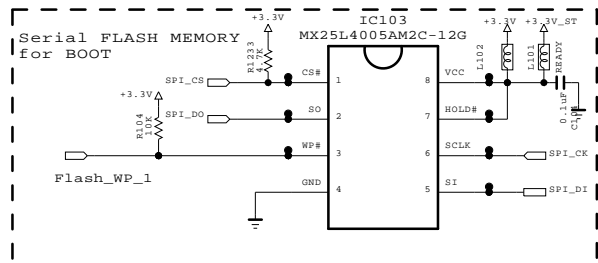
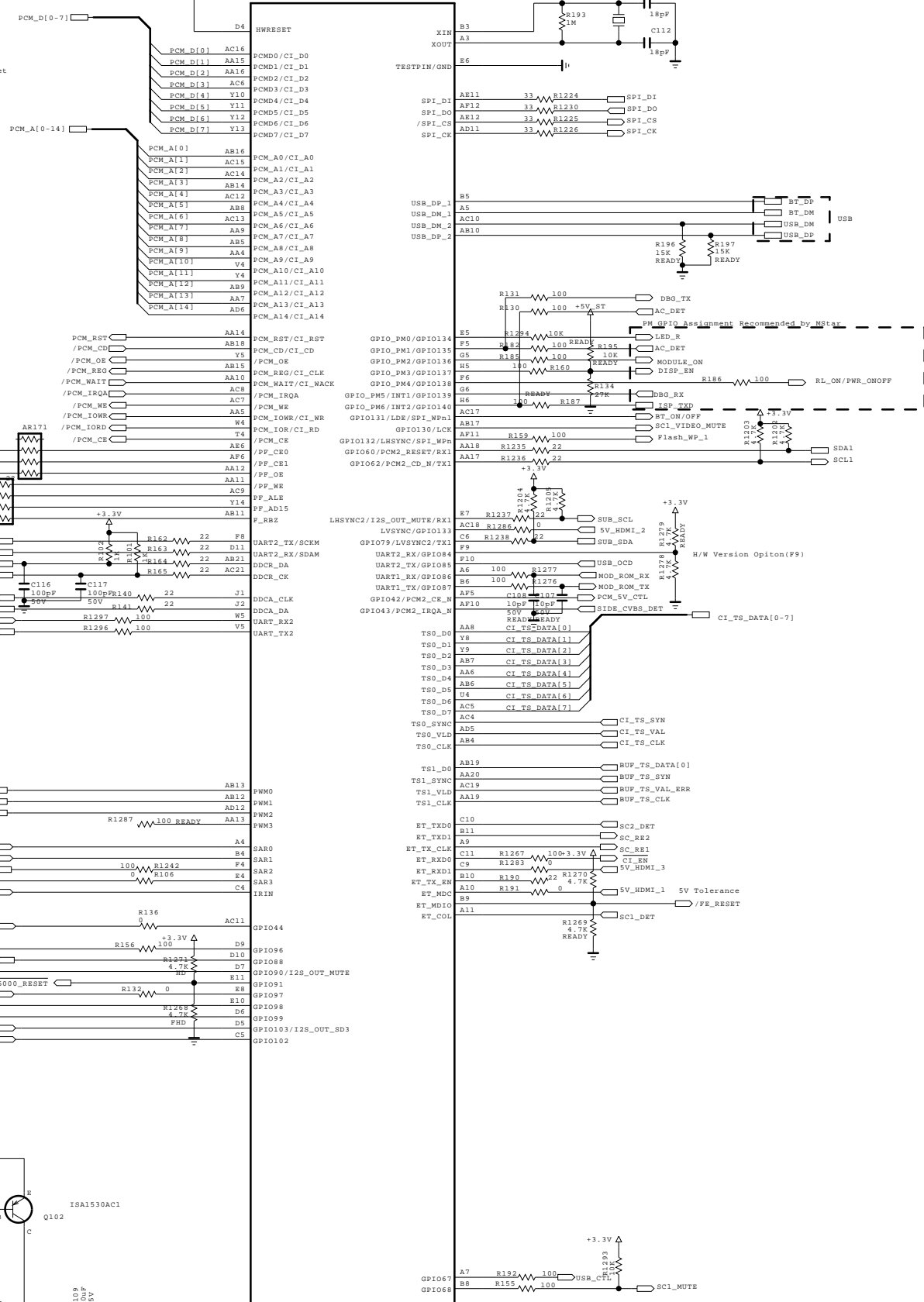

THE SYMBOL MARK OF THIS SCHEMATIC DIAGRAM INCORPORATES SPECIAL FEATURES IMPORTANT FOR PROTECTION FROM X-RADIATION. FILRE AND ELECTRICAL SHOCK HAZARDS, WHEN SERVICING IF IS ESSENTIAL THAT ONLY MANUFACTURERS SPECIFIED PARTS BE USED FOR THE CRITICAL COMPONENTS IN THE SYMBOL MARK OF THE SCHEMATIC.

**SECRET**  
LGElectronics



MODEL	MSD3368EV Platform	DATE	09/09/24
BLOCK	FLASH/NVRAM/GPIO	SHEET	1 / 10

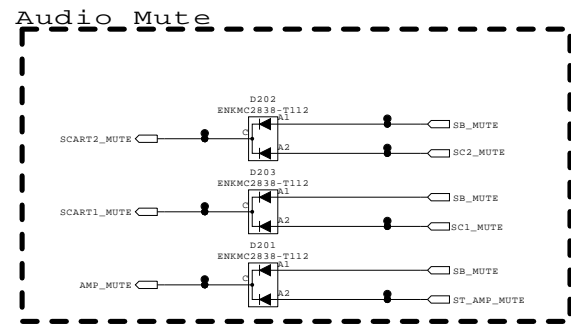

IC100  
LGE3369A (Saturn6 Non RM)

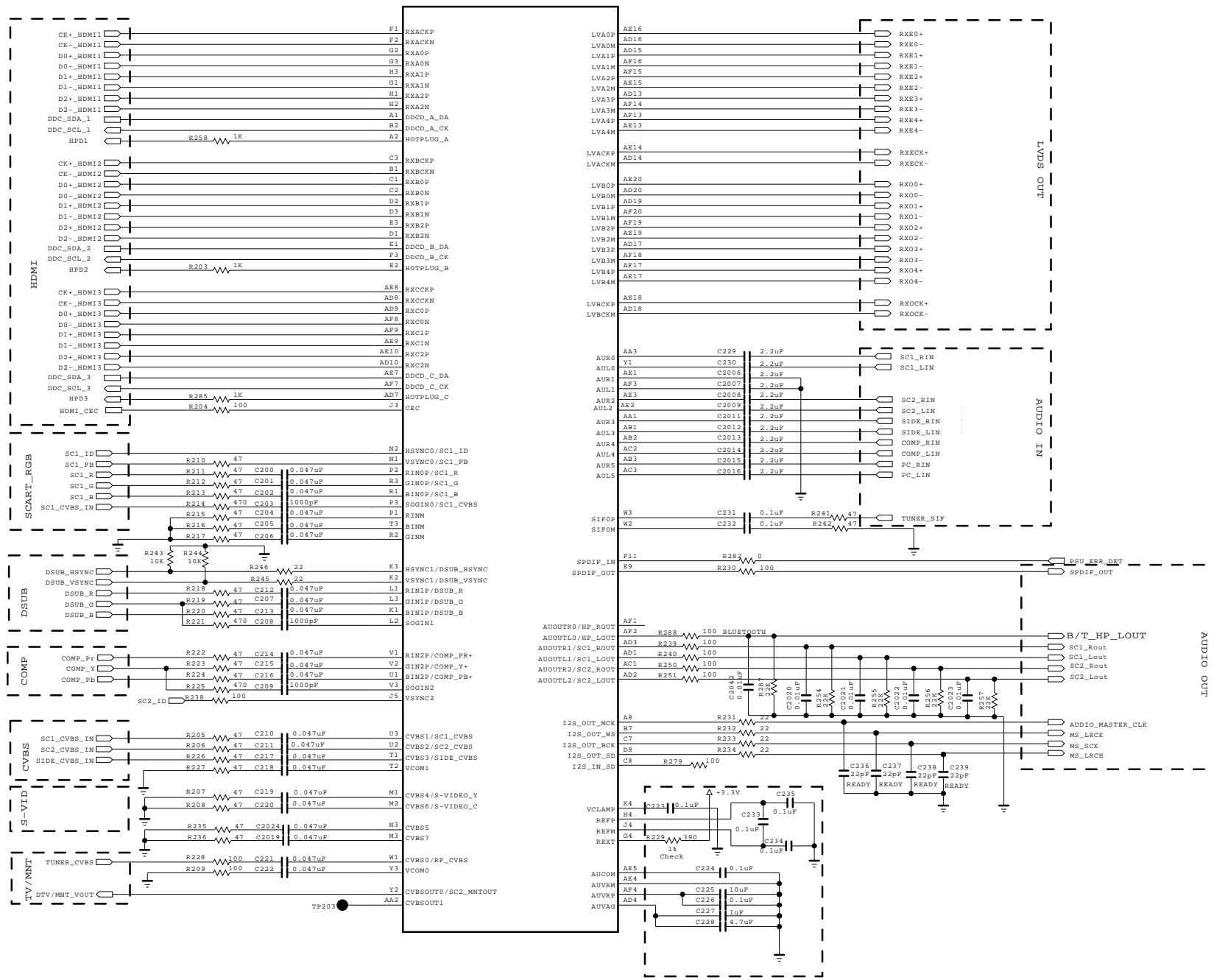

Close to IC  
as close as possible

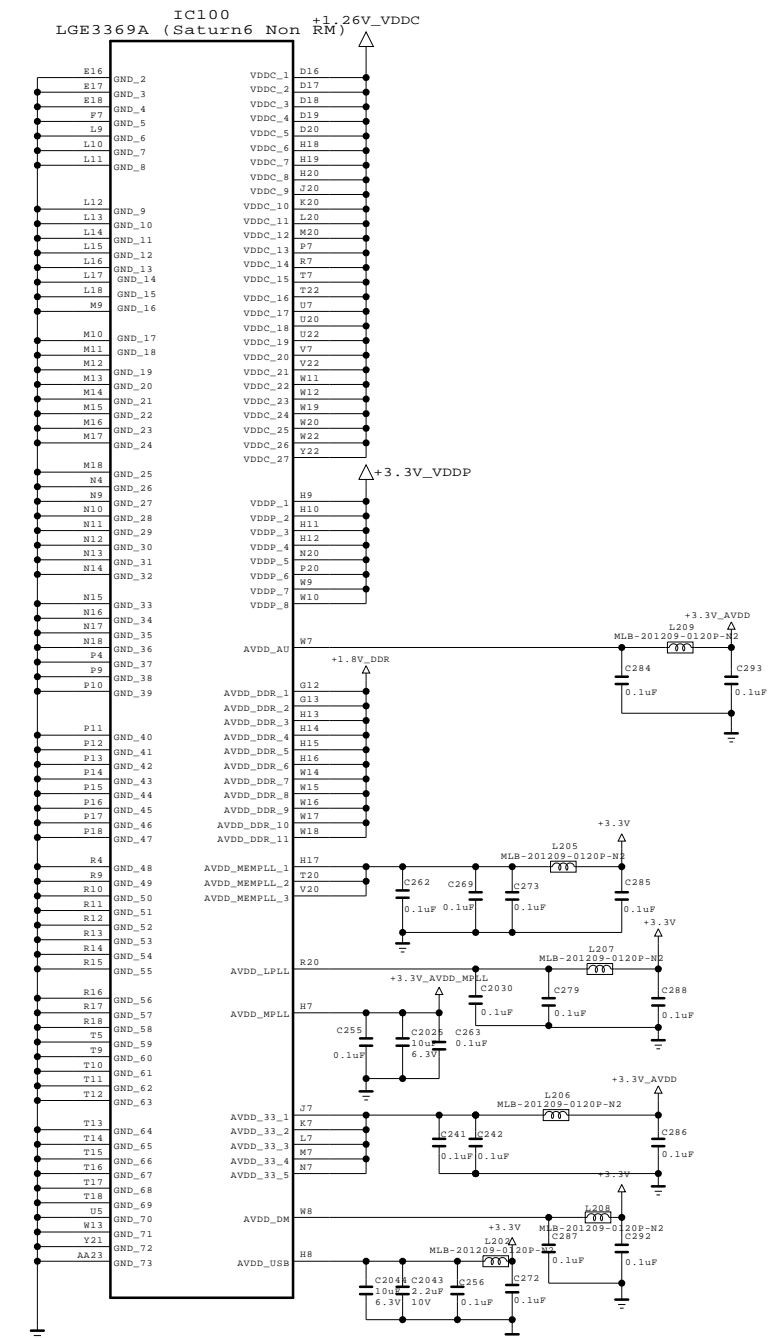
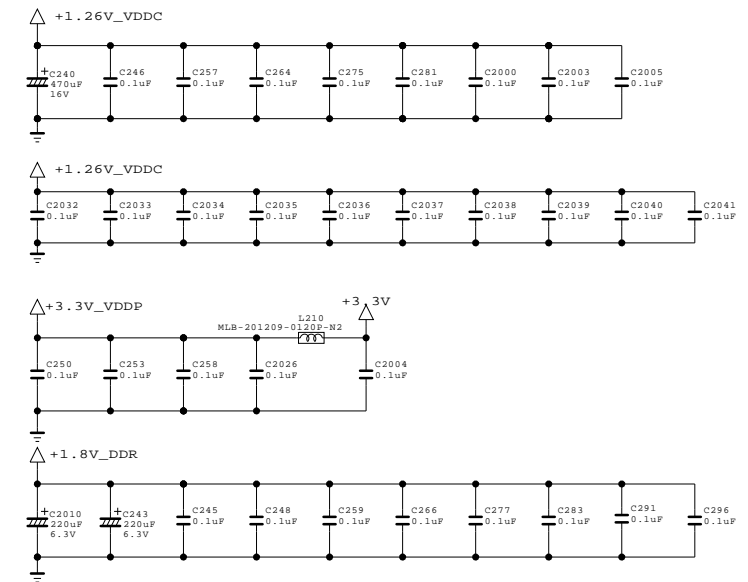

THE  $\Delta$  SYMBOL MARK OF THIS SCHEMATIC DIAGRAM INCORPORATES SPECIAL FEATURES IMPORTANT FOR PROTECTION FROM X-RADIATION. FILTRE AND ELECTRICAL SHOCK HAZARDS, WHEN SERVICING IF IS ESSENTIAL THAT ONLY MANUFACTURERS SPECIFIED PARTS BE USED FOR THE CRITICAL COMPONENTS IN THE  $\Delta$  SYMBOL MARK OF THE SCHEMATIC.

SECRET  
LGElectronics



MODEL	MSD3368EV Platform	DATE	
BLOCK	AV IN_OUT/LVDS/POWER	SHEET	2 / 10

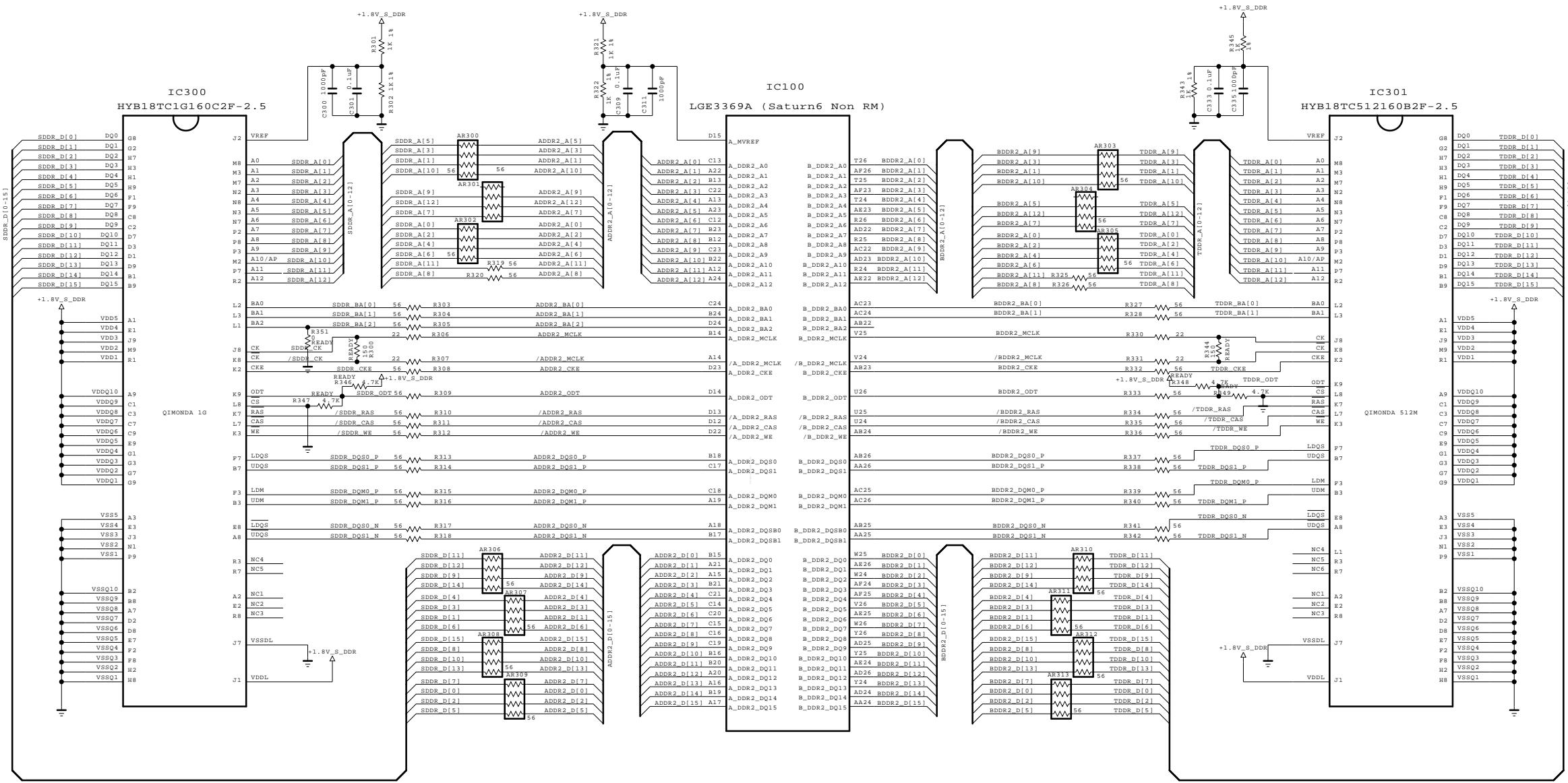
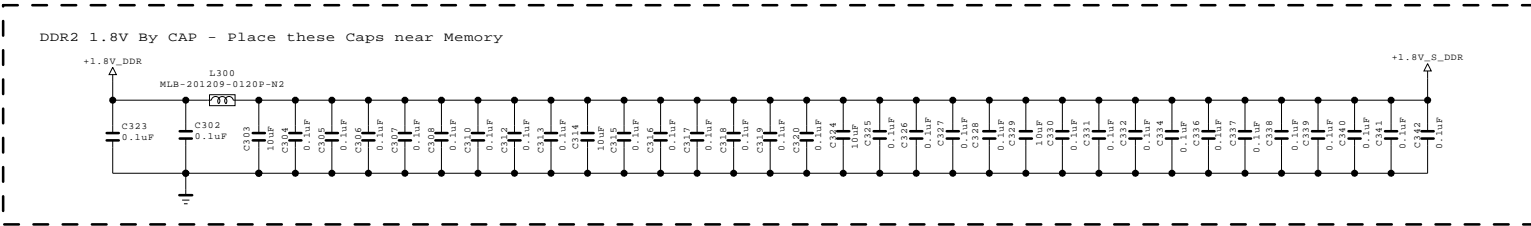

THE  $\Delta$  SYMBOL MARK OF THIS SCHEMATIC DIAGRAM INCORPORATES SPECIAL FEATURES IMPORTANT FOR PROTECTION FROM X-RADIATION. FILRE AND ELECTRICAL SHOCK HAZARDS, WHEN SERVICING IF IS ESSENTIAL THAT ONLY MANUFACTURES SPECIFIED PARTS BE USED FOR THE CRITICAL COMPONENTS IN THE  $\Delta$  SYMBOL MARK OF THE SCHEMATIC.

**SECRET**  
LGElectronics



MODEL	MSD3368EV Platform	DATE	
BLOCK	DDR2	SHEET	3 / 10





# Audio Amp

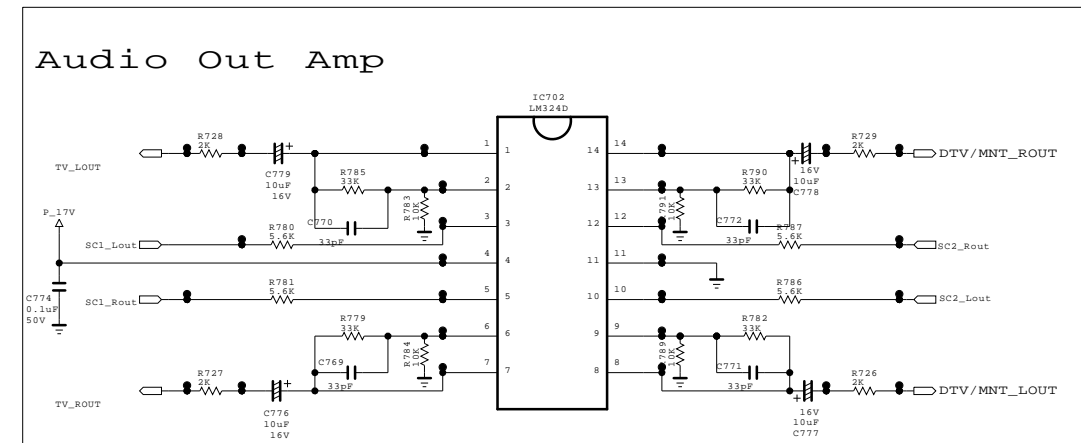
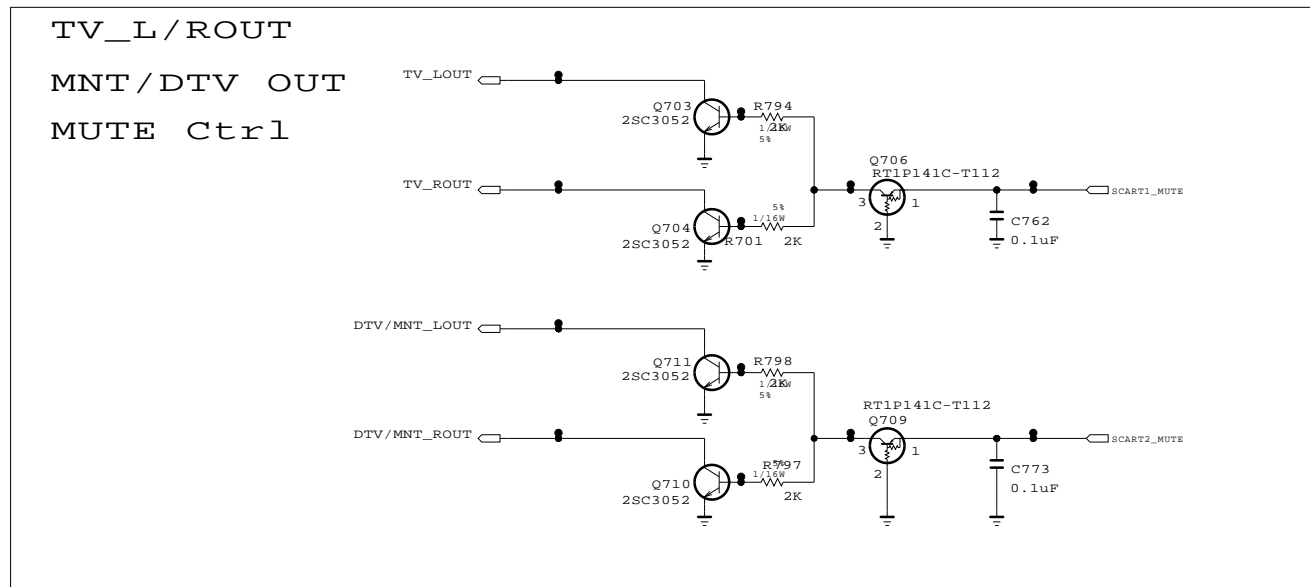
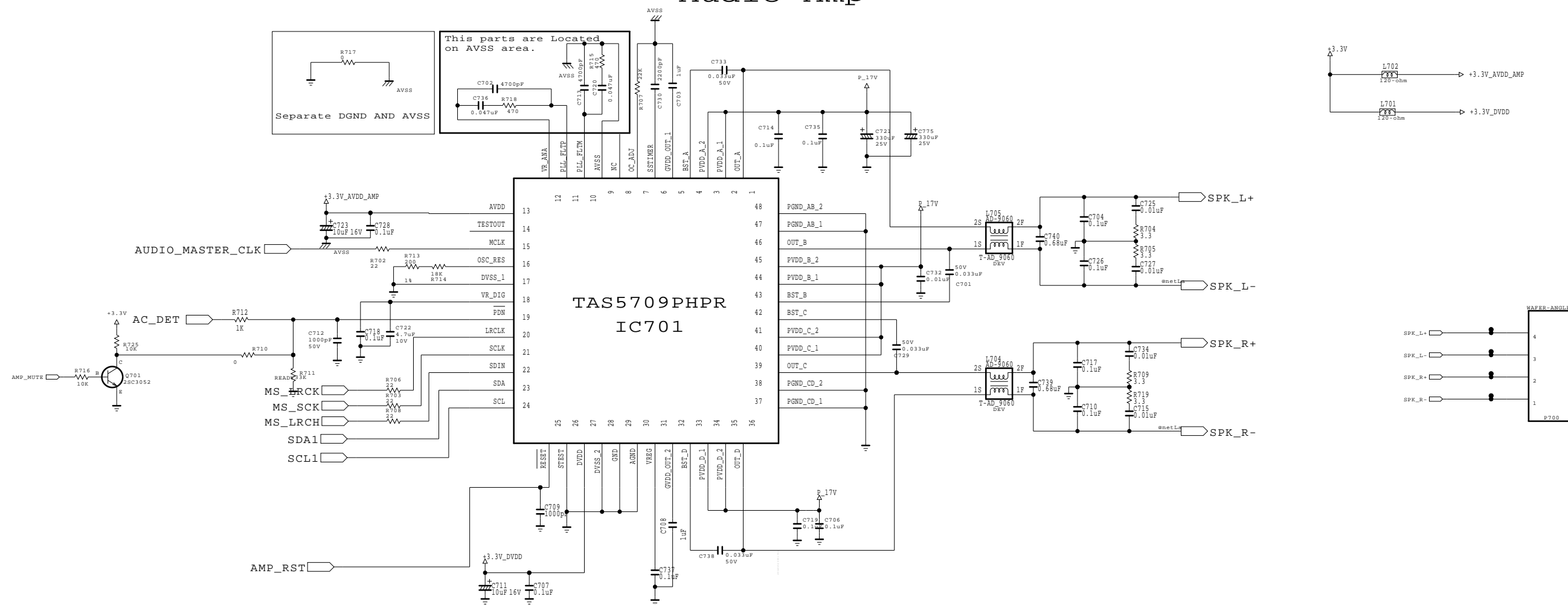

THE SYMBOL MARK OF THIS SCHEMATIC DIAGRAM INCORPORATES SPECIAL FEATURES IMPORTANT FOR PROTECTION FROM X-RADIATION. FILRE AND ELECTRICAL SHOCK HAZARDS, WHEN SERVICING IF IS ESSENTIAL THAT ONLY MANUFACTURES SPECIFIED PARTS BE USED FOR THE CRITICAL COMPONENTS IN THE SYMBOL MARK OF THE SCHEMATIC.

SECRET  
LGElectronics



MODEL	MSD3368EV Platform	DATE	
BLOCK	AUDIO	SHEET	6 / 10

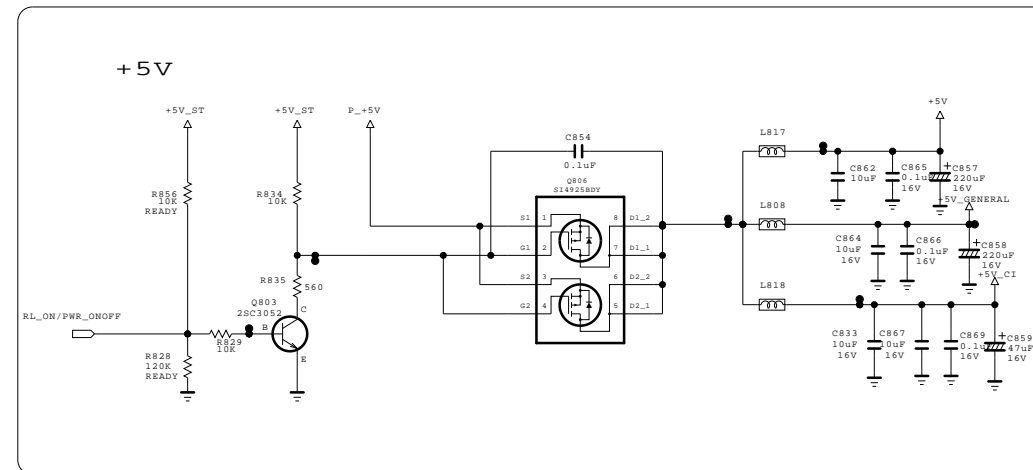
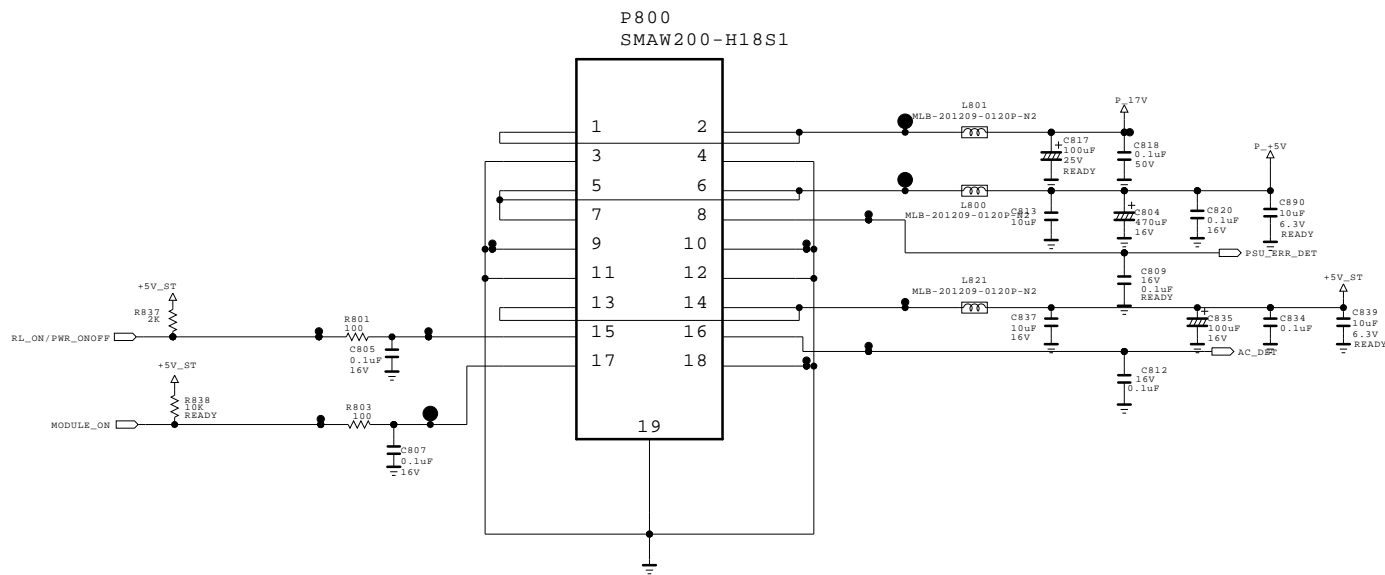

Stand-by +3.3V

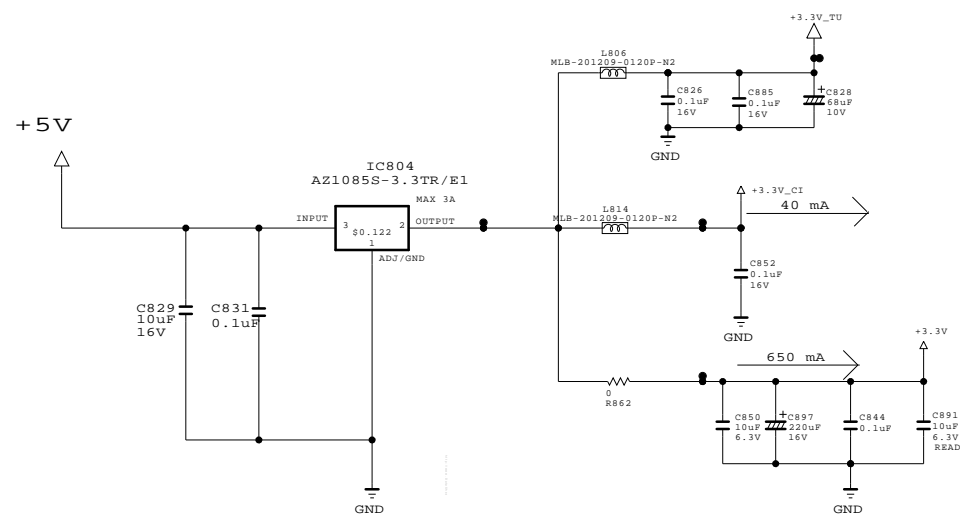
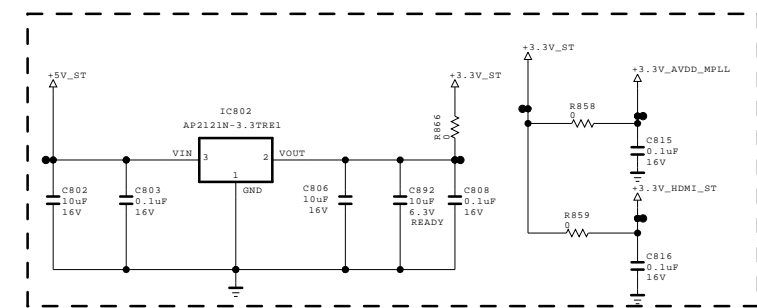

# Full SCART 1

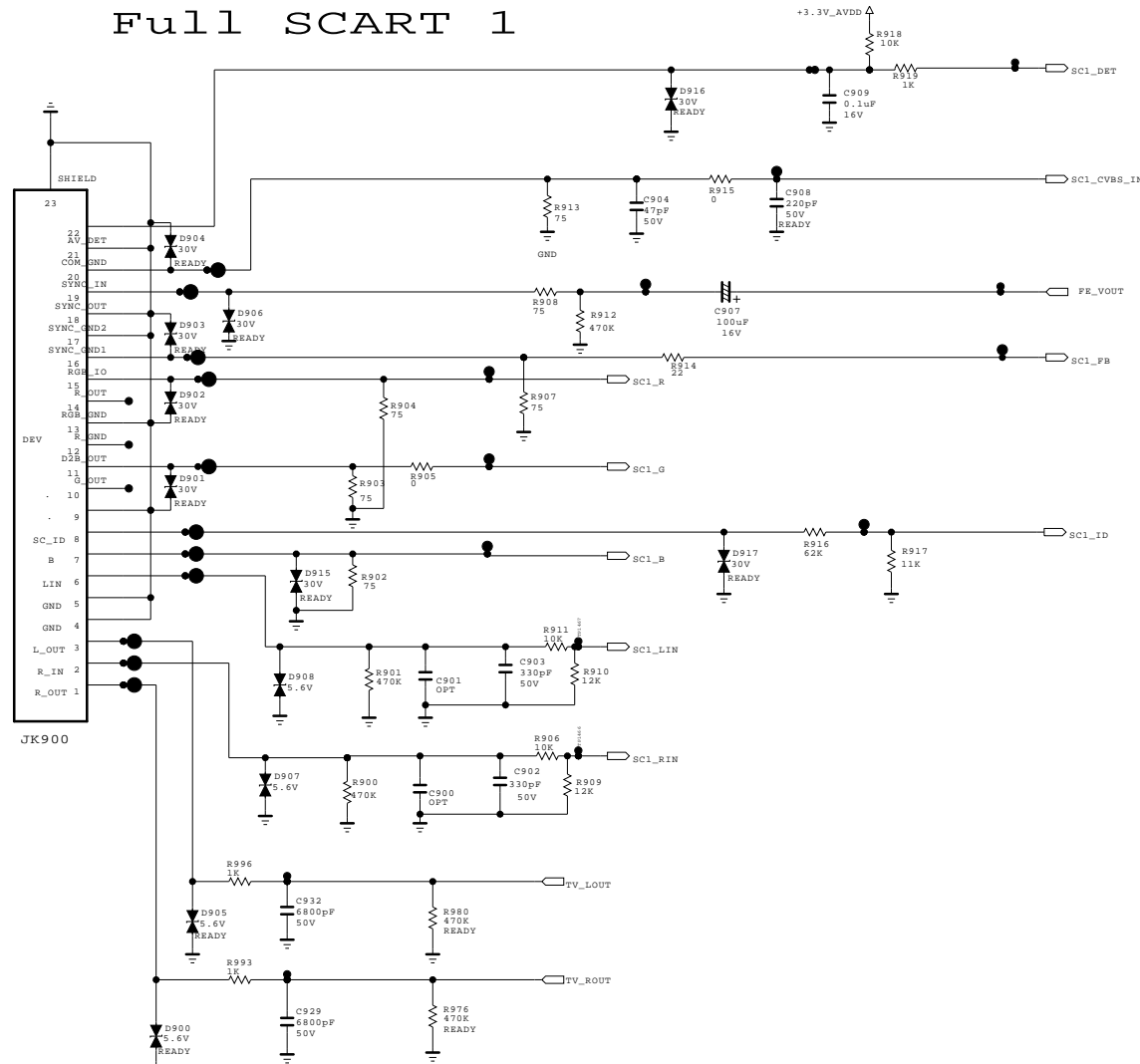

# Half SCART 2

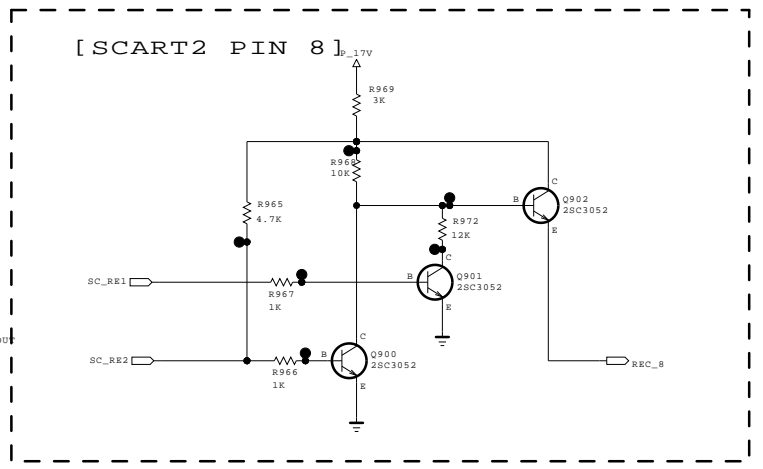
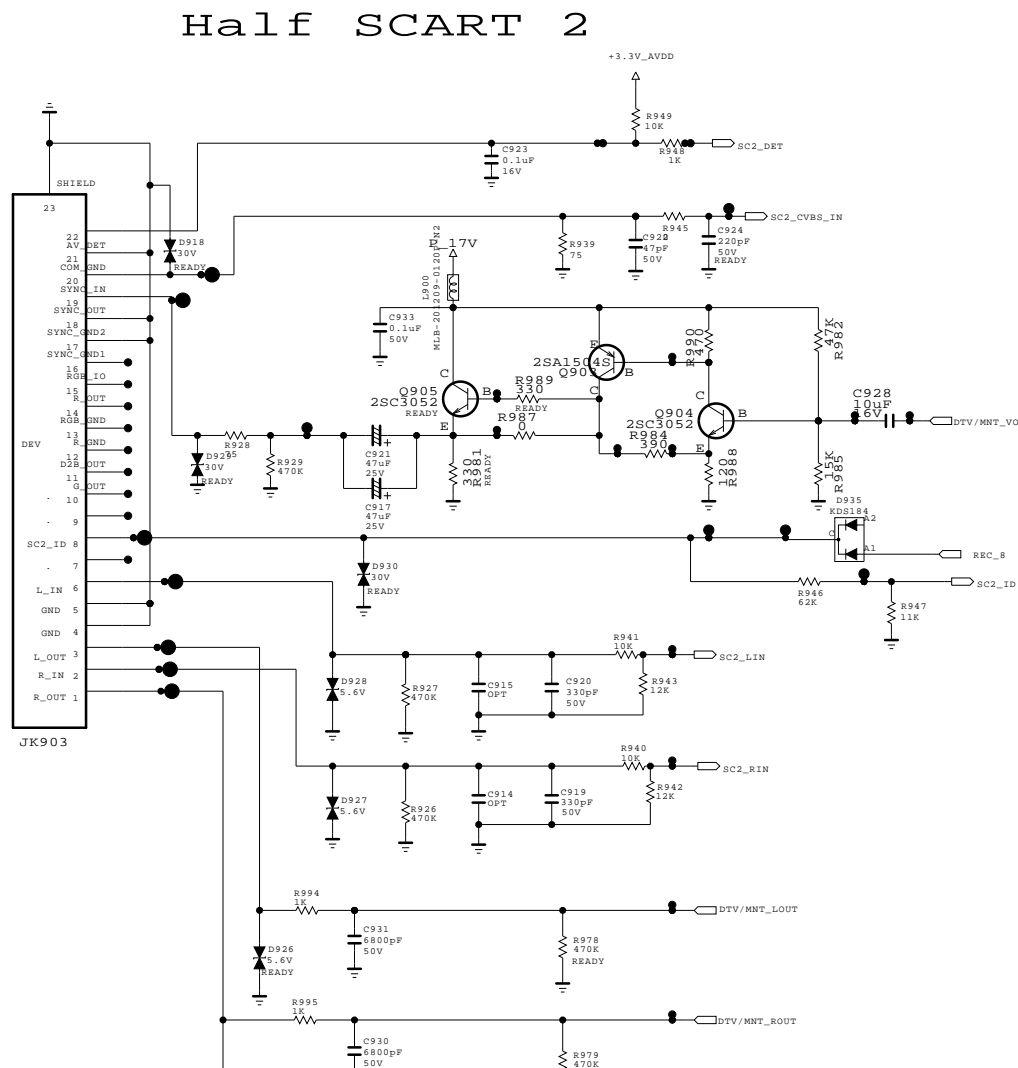

# COMPONENT

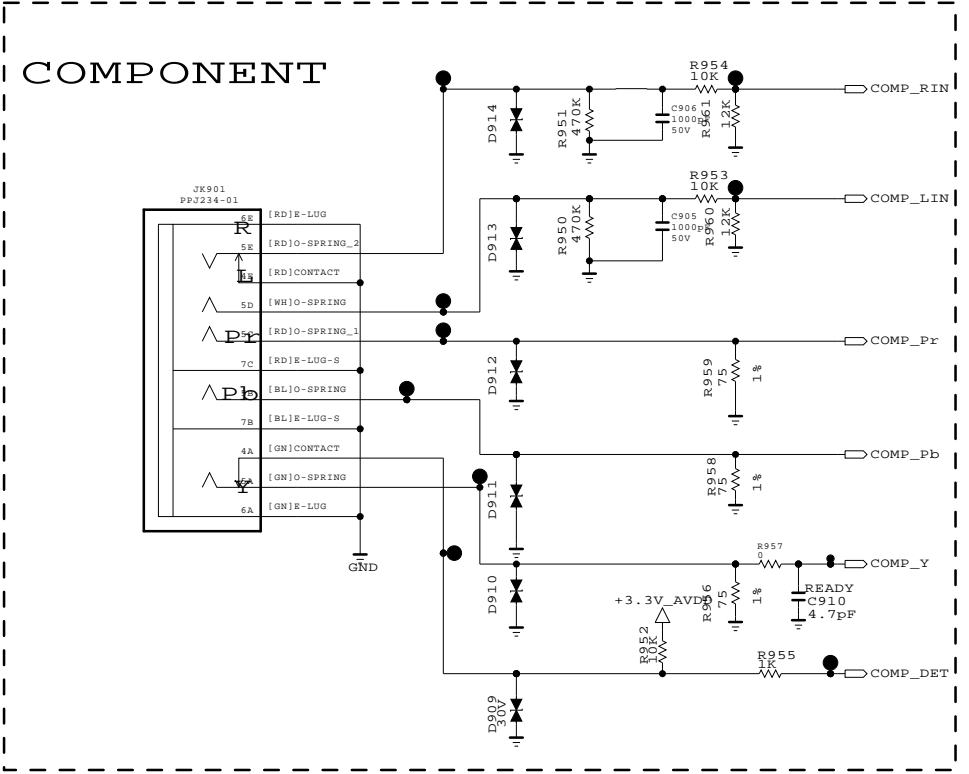

# SIDE CVBS

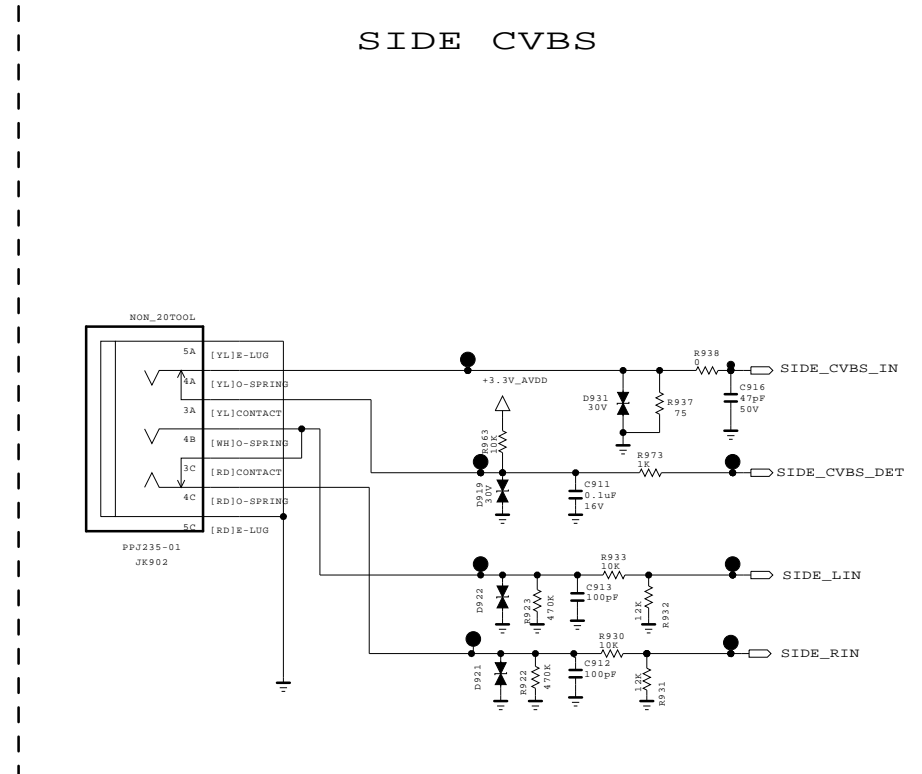

# USB

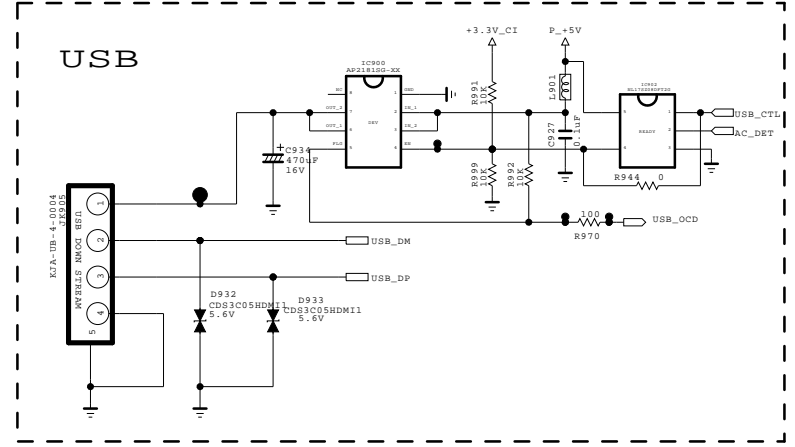

# SPDIF OPTIC JACK

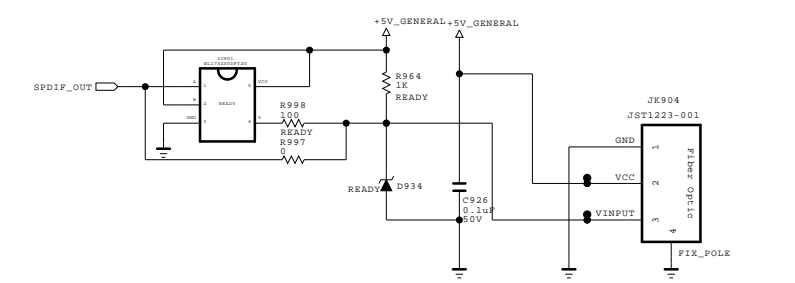

THE SYMBOL MARK OF THIS SCHEMATIC DIAGRAM INCORPORATES SPECIAL FEATURES IMPORTANT FOR PROTECTION FROM X-RADIATION. FILRE AND ELECTRICAL SHOCK HAZARDS, WHEN SERVICING IF IS ESSENTIAL THAT ONLY MANUFACTURES SPECIFIED PARTS BE USED FOR THE CRITICAL COMPONENTS IN THE SYMBOL MARK OF THE SCHEMATIC.

**SECRET**  
LGElectronics



MODEL	MSD3368EV Platform	DATE	
BLOCK	JACK	SHEET	8 / 10





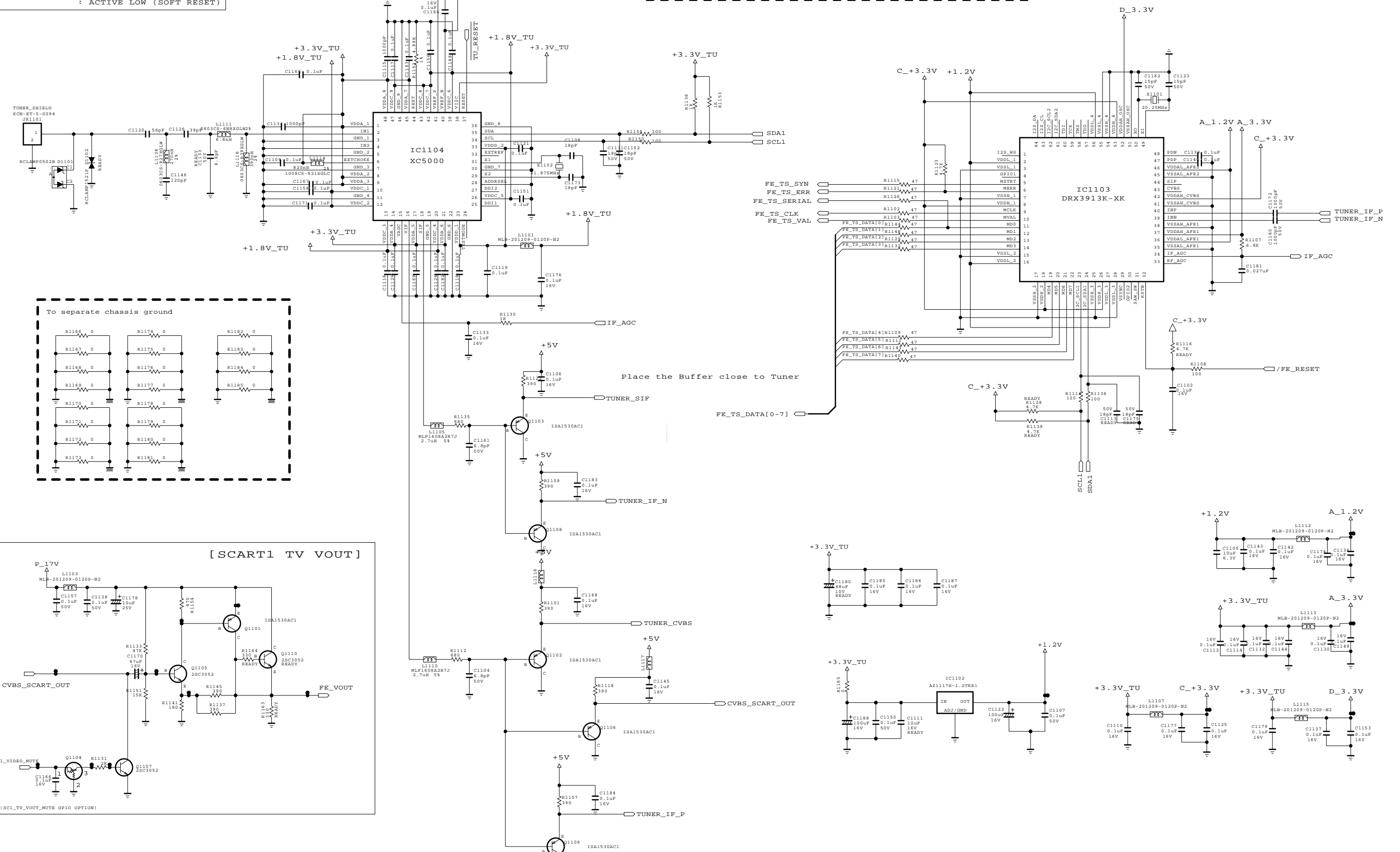
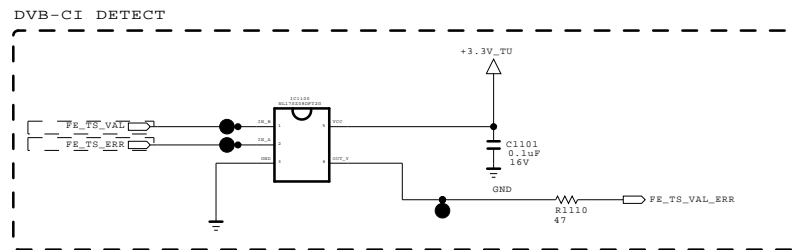
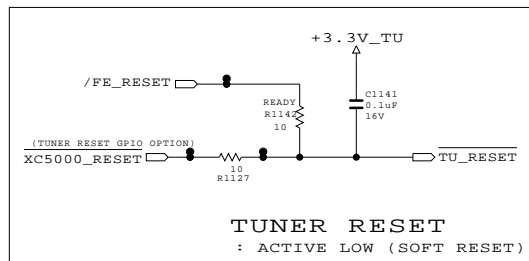

THE SYMBOL MARK OF THIS SCHEMATIC DIAGRAM INCORPORATES SPECIAL FEATURES IMPORTANT FOR PROTECTION FROM X-RADIATION. FILRE AND ELECTRICAL SHOCK HAZARDS, WHEN SERVICING IF IS ESSENTIAL THAT ONLY MANUFACTURERS SPECIFIED PARTS BE USED FOR THE CRITICAL COMPONENTS IN THE SYMBOL MARK OF THE SCHEMATIC.

**SECRET**  
LGElectronics



<b>MODEL</b>	MSD3368EV Platform	<b>DATE</b>	
<b>BLOCK</b>	TUNER	<b>SHEET</b>	10 / 10

