

**Fast CMOS
10-Bit Buffers**

Product Features

- PI74FCT827/828/2827/2828T are pin compatible with bipolar FAST™ Series at a higher speed and lower power consumption
- 25Ω series resistor on all outputs (FCT2XXX only)
- TTL input and output levels
- Low ground bounce outputs
- Extremely low static power
- Hysteresis on all inputs
- Industrial operating temperature range: -40°C to +85°C
- Packages available:
 - 24-pin 300-mil wide plastic DIP (P24)
 - 24-pin 150-mil wide plastic QSOP (Q24)
 - 24-pin 150-mil wide plastic TQSOP (R24)
 - 24-pin 300-mil wide plastic SOIC (S24)

Product Description

Pericom Semiconductor's PI74FCT series of logic circuits are produced in the Company's advanced 0.8 micron CMOS technology, achieving industry leading speed grades. All PI74FCT2XXX devices have a built-in 25-ohm series resistor on all outputs to reduce noise because of reflections, thus eliminating the need for an external terminating resistor.

The PI74FCT827/828T and the PI74FCT2827/2828T are 10-bit wide bus drivers providing high-performance bus interface buffering for wide address/data paths or buses carrying parity. The 10-bit buffers have NAND-ed output enables for maximum control flexibility. They are designed for high-capacitance load drive capability, while providing low-capacitance bus loading at both inputs and outputs. The PI74FCT827/2827T is a non-inverting of the PI74FCT828/2828T.

Device models available upon request.

Logic Block Diagram

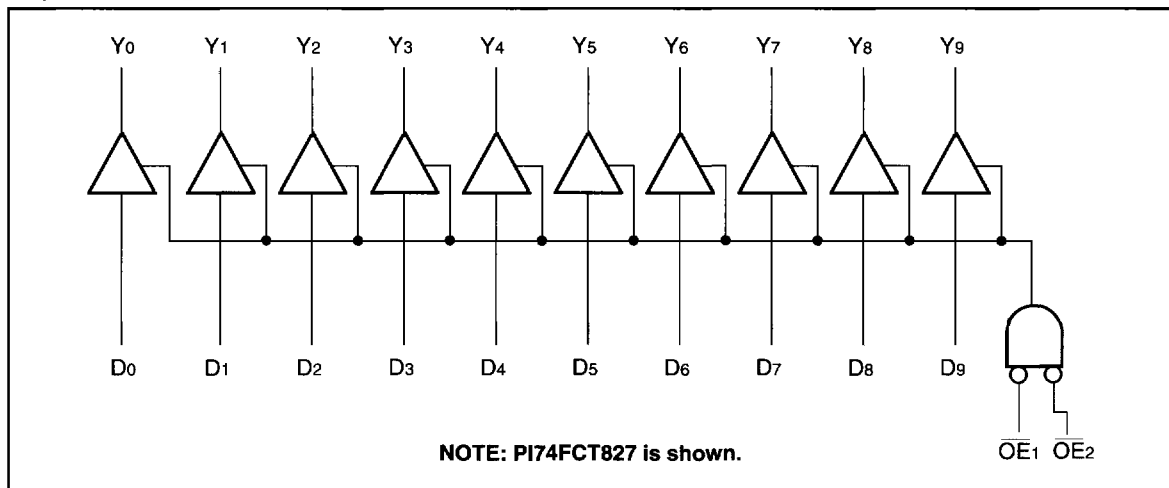

Product Pin Configuration

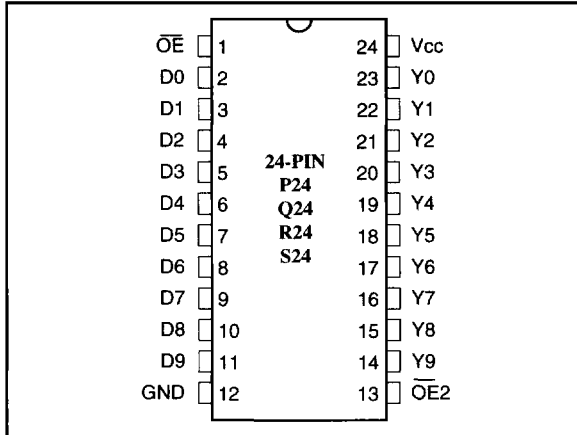

Product Pin Description

Pin Name	Description
$\overline{OE}N$	Output Enable Input (Active LOW)
D0-D9	10-bit Data Inputs
Y0-Y9	10-bit Data Outputs
GND	Ground
Vcc	Power

PI74FCT827/2827T

Truth Table (Non-Inverting)⁽¹⁾

Function	Inputs			Outputs
	$\overline{OE}1$	$\overline{OE}2$	D_N	Y_N
Transparent	L	L	L	L
	L	L	H	H
Three-State	H	X	X	Z
	X	H	X	Z

PI74FCT828/2828T

Truth Table (Inverting)⁽¹⁾

Function	Inputs			Outputs
	$\overline{OE}1$	$\overline{OE}2$	D_N	Y_N
Transparent	L	L	L	H
	L	L	H	L
Three-State	H	X	X	Z
	X	H	X	Z

- H = High Voltage Level
L = Low Voltage Level
X = Don't Care
Z = High Impedance

Maximum Ratings

(Above which the useful life may be impaired. For user guidelines, not tested.)

Storage Temperature	-65°C to +150°C
Ambient Temperature with Power Applied	-40°C to +85°C
Supply Voltage to Ground Potential (Inputs & Vcc Only)	-0.5V to +7.0V
Supply Voltage to Ground Potential (Outputs & D/O Only)	-0.5V to +7.0V
DC Input Voltage	-0.5V to +7.0V
DC Output Current	120mA
Power Dissipation	0.5W

Note:

Stresses greater than those listed under MAXIMUM RATINGS may cause permanent damage to the device. This is a stress rating only and functional operation of the device at these or any other conditions above those indicated in the operational sections of this specification is not implied. Exposure to absolute maximum rating conditions for extended periods may affect reliability.

DC Electrical Characteristics (Over the Operating Range, TA = -40°C to +85°C, VCC = 5.0V ± 5%)

Parameters	Description	Test Conditions ⁽¹⁾		Min.	Typ ⁽²⁾	Max.	Units
V _{OH}	Output HIGH Voltage	V _{CC} = Min., V _{IN} = V _{IH} or V _{IL}	I _{OH} = -15.0mA	2.4	3.0		V
V _{OL}	Output LOW Current	V _{CC} = Min., V _{IN} = V _{IH} or V _{IL}	I _{OL} = 48mA		0.3	0.50	V
V _{OL}	Output LOW Current	V _{CC} = Min., V _{IN} = V _{IH} or V _{IL}	I _{OL} = 12mA (25Ω Series)		0.3	0.50	V
V _{IH}	Input HIGH Voltage	Guaranteed Logic HIGH Level		2.0			V
V _{IL}	Input LOW Voltage	Guaranteed Logic LOW Level				0.8	V
I _{IH}	Input HIGH Current	V _{CC} = Max.	V _{IN} = V _{CC}			1	μA
I _{IL}	Input LOW Current	V _{CC} = Max.	V _{IN} = GND			-1	μA
I _{OZH}	High Impedance	V _{CC} = Max.	V _{OUT} = 2.7V			1	μA
I _{OZL}	Output Current		V _{OUT} = 0.5V			-1	μA
V _{IK}	Clamp Diode Voltage	V _{CC} = Min., I _{IN} = -18mA			-0.7	-1.2	V
I _{OFF}	Power Down Disable	V _{CC} = GND, V _{OUT} = 4.5V		—	—	100	μA
I _{OS}	Short Circuit Current	V _{CC} = Max. ⁽³⁾ , V _{OUT} = GND		-60	-120		mA
V _H	Input Hysteresis				200		mV

Capacitance (TA = 25°C, f = 1 MHz)

Parameters ⁽⁴⁾	Description	Test Conditions	Typ	Max.	Units
C _{IN}	Input Capacitance	V _{IN} = 0V	6	10	pF
C _{OUT}	Output Capacitance	V _{OUT} = 0V	8	12	pF

Notes:

1. For Max. or Min. conditions, use appropriate value specified under Electrical Characteristics for the applicable device type.
2. Typical values are at V_{CC} = 5.0V, +25°C ambient and maximum loading.
3. Not more than one output should be shorted at one time. Duration of the test should not exceed one second.
4. This parameter is determined by device characterization but is not production tested.

Power Supply Characteristics

Parameters	Description	Test Conditions ⁽¹⁾		Min.	Typ ⁽²⁾	Max.	Units
I _{CC}	Quiescent Power Supply Current	V _{CC} = Max.	V _{IN} = GND or V _{CC}		0.1	500	μA
ΔI _{CC}	Supply Current per Input @ TTL HIGH	V _{CC} = Max.	V _{IN} = 3.4V ⁽³⁾		0.5	2.0	mA
I _{CCD}	Supply Current per Input per MHz ⁽⁴⁾	V _{CC} = Max., Outputs Open OE1 = OE2 = GND One Input Toggling 50% Duty Cycle	V _{IN} = V _{CC} V _{IN} = GND		0.15	0.25	mA/ MHz
I _C	Total Power Supply Current ⁽⁶⁾	V _{CC} = Max., Outputs Open f _{CP} = 10 MHz 50% Duty Cycle OE1 = OE2 = GND f _I = 5 MHz One Bit Toggling	V _{IN} = V _{CC} V _{IN} = GND		1.5	3.5 ⁽⁵⁾	mA
			V _{IN} = 3.4V V _{IN} = GND		1.8	4.5 ⁽⁵⁾	
		V _{CC} = Max., Outputs Open f _{CP} = 10 MHz 50% Duty Cycle OE1 = OE2 = GND Eight Bits Toggling f _I = 2.5 MHz 50% Duty Cycle	V _{IN} = V _{CC} V _{IN} = GND		3.0	6.0 ⁽⁵⁾	
			V _{IN} = 3.4V V _{IN} = GND		5.0	14.0 ⁽⁵⁾	

Notes:

- For Max. or Min. conditions, use appropriate value specified under Electrical Characteristics for the applicable device.
- Typical values are at V_{CC} = 5.0V, +25°C ambient.
- Per TTL driven input (V_{IN} = 3.4V); all other inputs at V_{CC} or GND.
- This parameter is not directly testable, but is derived for use in Total Power Supply Calculations.
- Values for these conditions are examples of the I_{CC} formula. These limits are guaranteed but not tested.

$$6. I_C = I_{\text{QUIESCENT}} + I_{\text{INPUTS}} + I_{\text{DYNAMIC}}$$

$$I_C = I_{CC} + \Delta I_{CC} D_H N_T + I_{CCD} (f_{CP}/2 + f_I N_I)$$

I_{CC} = Quiescent Current

ΔI_{CC} = Power Supply Current for a TTL High Input (V_{IN} = 3.4V)

D_H = Duty Cycle for TTL Inputs High

N_T = Number of TTL Inputs at D_H

I_{CCD} = Dynamic Current Caused by an Input Transition Pair (HLH or LHL)

f_{CP} = Clock Frequency for Register Devices (Zero for Non-Register Devices)

f_I = Input Frequency

N_I = Number of Inputs at f_I

All currents are in milliamps and all frequencies are in megahertz.

PI74FCT827/2827T (non-inverting) Switching Characteristics over Operating Range

Parameters	Description	Conditions ⁽¹⁾	827AT/2827AT		827BT/2827BT		827CT/2827CT		827DT		Units
			Com.		Com.		Com.		Com.		
			Min.	Max.	Min.	Max.	Min.	Max.	Min.	Max.	
t _{PLH} t _{PHL}	Propagation Delay D _N to Y _N	C _L = 50pF R _L = 500Ω	1.5	6.5	1.5	5.0	1.5	4.4	1.5	3.8	ns
		C _L = 300pF ⁽³⁾ R _L = 500Ω	1.5	15.0	1.5	13.0	1.5	10.0	1.5	7.5	
t _{PZH} t _{PZL}	Output Enable Time O _{EN} to Y _N	C _L = 50pF R _L = 500Ω	1.5	9.5	1.5	8.0	1.5	7.0	1.5	5.0	
		C _L = 300pF ⁽³⁾ R _L = 500Ω	1.5	23.0	1.5	15.0	1.5	14.0	1.5	9.0	
t _{PHZ} t _{PLZ}	Output Disable Time ⁽³⁾ O _{EN} to Y _N	C _L = 5pF ⁽³⁾ R _L = 500Ω	1.5	8.5	1.5	6.0	1.5	5.7	1.5	4.3	
		C _L = 50pF R _L = 500Ω	1.5	10.0	1.5	7.0	1.5	6.0	1.5	4.3	

PI74FCT828/2828T (inverting) Switching Characteristics over Operating Range

Parameters	Description	Conditions ⁽¹⁾	828AT/2828AT		828BT/2828BT		828CT		Units
			Com.		Com.		Com.		
			Min.	Max.	Min.	Max.	Min.	Max.	
t _{PLH} t _{PHL}	Propagation Delay D _N to Y _N	C _L = 50 pF R _L = 500Ω	1.5	6.5	1.5	5.5	1.5	4.4	ns
		C _L = 300 pF ⁽³⁾ R _L = 500Ω	1.5	15.0	1.5	13.0	1.5	10.0	ns
t _{PZH} t _{PZL}	Output Enable Time O _{EN} to Y _N	C _L = 50 pF R _L = 500Ω	1.5	9.5	1.5	8.0	1.5	7.0	ns
		C _L = 300 pF ⁽³⁾ R _L = 500Ω	1.5	23.0	1.5	15.0	1.5	14.0	ns
t _{PHZ} t _{PLZ}	Output Disable Time ⁽³⁾ O _{EN} to Y _N	C _L = 5 pF ⁽³⁾ R _L = 500Ω	1.5	8.5	1.5	6.0	1.5	5.7	ns
		C _L = 50 pF R _L = 500Ω	1.5	10.0	1.5	7.0	1.5	6.0	ns

Notes:

1. See test circuit and wave forms.
2. Minimum limits are guaranteed but not tested on Propagation Delays.
3. This parameter is guaranteed but not production tested.