

## Technical Data

DV74ACT04 Available Q2, 1995

### Hex Inverter

This device contains six independent three-stage-inverters, each of which performs the logic INVERT function.

- Advanced very high speed CMOS
- Outputs source/sink 24 mA
- Transmission line driving 50 ohms
- ACT has TTL compatible inputs
- AC device operation guaranteed from 2 to 6 volts
- DC & AC Parameters guaranteed over  $-40$  to  $+85^{\circ}\text{C}$

**DV74AC04**  
**DV74ACT04**

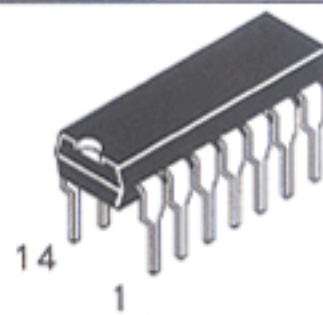

N Suffix  
Plastic DIP  
AVG-001 Case

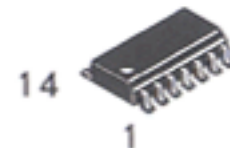

D Suffix  
Plastic SOP  
AVG-002 Case

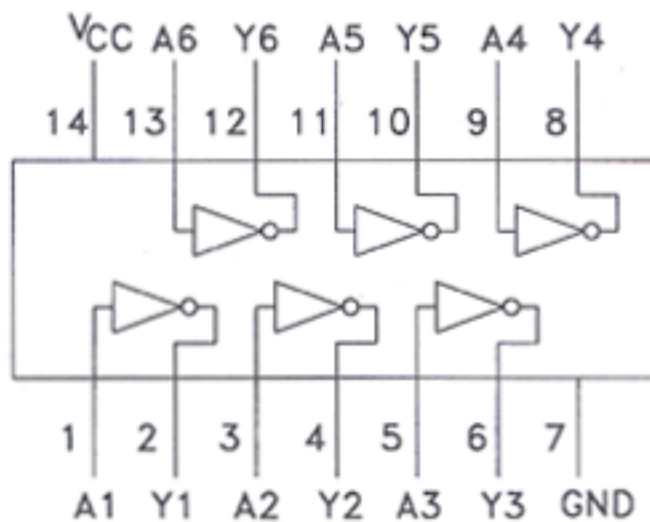

#### TRUTH TABLE

Inputs	Outputs
A	Y
L	H
H	L

H=High Level Logic  
L=Low Level Logic  
X=Don't Care

#### ABSOLUTE MAXIMUM RATINGS

Maximum ratings are those values beyond which damage to the device may occur.

Symbol	Parameter	AC04, ACT04	Unit
V <sub>CC</sub>	DC Supply Voltage (Referenced to GND)	- 0.5 to +7.0	V
V <sub>IN</sub>	DC Input Voltage (Referenced to GND)	- 0.5 to V <sub>CC</sub> +0.5	V
V <sub>OUT</sub>	DC Output Voltage (Referenced to GND)	- 0.5 to V <sub>CC</sub> +0.5	V
I <sub>IN</sub>	DC Input Current, per Pin	± 20	mA
I <sub>OUT</sub>	DC Output Sink/Source Current, per Pin	± 50	mA
I <sub>CC</sub>	DC V <sub>CC</sub> or GND Current per Output Pin	± 50	mA
T <sub>STG</sub>	Storage Temperature	- 65 to +150	°C

#### GUARANTEED OPERATING CONDITIONS

Symbol	Parameter	Min	Typ	Max	Unit	
V <sub>CC</sub>	Supply Voltage	'AC	2.0	5.0	6.0	V
		'ACT	4.5	5.0	5.5	
V <sub>IN</sub> , V <sub>OUT</sub>	DC Input Voltage, Output Voltage, (Ref. to GND)	0		V <sub>CC</sub>	V	
t <sub>r</sub> , t <sub>f</sub>	Input Rise and Fall Time (Note 1) AC Devices	V <sub>CC</sub> @ 3.0 V		150	ns/V	
		V <sub>CC</sub> @ 4.5 V		40	ns/V	
		V <sub>CC</sub> @ 5.5 V		25	ns/V	



**GUARANTEED OPERATING CONDITIONS (continued)**

Symbol	Parameter	Min	Typ	Max	Unit
t <sub>r</sub> , t <sub>f</sub>	Input Rise and Fall Time (Note 2) 'ACT Devices	V <sub>CC</sub> @ 4.5 V		10	ns/V
		V <sub>CC</sub> @ 5.5 V		8.0	ns/V
T <sub>A</sub>	Operating Ambient Temperature Range	-40	25	85	°C
C <sub>IN</sub>	Input Capacitance	V <sub>CC</sub> = 5.0 V	4.5		pF
C <sub>PD</sub>	Power Dissipation Capacitance	V <sub>CC</sub> = 5.0 V	30		pF

1. V<sub>IN</sub> from 30% to 70% V<sub>CC</sub>
2. V<sub>IN</sub> from 0.8 to 2.0 V

**AC — 04**

**DC ELECTRICAL CHARACTERISTICS**

Symbol	Parameter	Conditions	V <sub>CC</sub> (V)	AC04			Unit		
				T <sub>A</sub> = +25°C		T <sub>A</sub> = -40 to +85°C			
				Typ	Guaranteed Limits				
V <sub>IH</sub>	Minimum High Level Input Voltage	V <sub>OUT</sub> = 0.1V or V <sub>CC</sub> - 0.1 V	3.0	1.5	2.1	2.1	V		
			4.5	2.25	3.15	3.15			
			5.5	2.75	3.85	3.85			
V <sub>IL</sub>	Maximum Low Level Input Voltage	V <sub>OUT</sub> = 0.1V or V <sub>CC</sub> - 0.1 V	3.0	1.5	0.9	0.9	V		
			4.5	2.25	1.35	1.35			
			5.5	2.75	1.65	1.65			
V <sub>OH</sub>	Minimum High Level Output Voltage	I <sub>OUT</sub> = -50 μA	3.0	2.99	2.9	2.9	V		
			4.5	4.49	4.4	4.4			
			5.5	5.49	5.4	5.4			
		V <sub>IN</sub> = V <sub>IL</sub> or V <sub>IH</sub>	I <sub>OH</sub>	-12mA	3.0		2.56	2.46	V
				-24mA	4.5		3.86	3.76	
		-24mA	5.5		4.86	4.76			
V <sub>OL</sub>	Maximum Low Level Output Voltage	I <sub>OUT</sub> = 50 μA	3.0	0.002	0.1	0.1	V		
			4.5	0.001	0.1	0.1			
			5.5	0.001	0.1	0.1			
		V <sub>IN</sub> = V <sub>IL</sub> or V <sub>IH</sub>	I <sub>OL</sub>	12mA	3.0		0.36	0.44	V
				24mA	4.5		0.36	0.44	
		24mA	5.5		0.36	0.44			
I <sub>IN</sub>	Maximum Input Leakage Current	V <sub>IN</sub> = V <sub>CC</sub> or GND	5.5		±0.1	±1.0	μA		
I <sub>CC</sub>	Maximum Quiescent Supply Current	V <sub>IN</sub> = V <sub>CC</sub> or GND	5.5		4.0	40	μA		

04

**AC CHARACTERISTICS over full operating conditions**

Symbol	Parameter	V <sub>CC</sub> ±10% (V)	AC04				Unit
			T <sub>A</sub> = +25°C C <sub>L</sub> = 50 pF		T <sub>A</sub> = -40°C to +85°C C <sub>L</sub> = 50 pF		
			Min	Max	Min	Max	
t <sub>PLH</sub>	Propagation Delay	3.3	1.5	9.0	1.0	10	ns
		5.0	1.5	7.0	1.0	7.5	
t <sub>PHL</sub>	Propagation Delay	3.3	1.5	8.5	1.0	9.5	ns
		5.0	1.5	6.5	1.0	7.0	

**DC ELECTRICAL CHARACTERISTICS**

Symbol	Parameter	Conditions	V <sub>CC</sub> (V)	ACT04			Unit
				T <sub>A</sub> = +25°C		T <sub>A</sub> = -40 to +85°C	
				Typ	Guaranteed Limits		
V <sub>IH</sub>	Minimum High Level Input Voltage	V <sub>OUT</sub> = 0.1V or V <sub>CC</sub> - 0.1 V	4.5 5.5	1.5 1.5	2.0 2.0	2.0 2.0	V
V <sub>IL</sub>	Maximum Low Level Input Voltage	V <sub>OUT</sub> = 0.1V or V <sub>CC</sub> - 0.1 V	4.5 5.5	1.5 1.5	0.8 0.8	0.8 0.8	V
V <sub>OH</sub>	Minimum High Level Output Voltage	I <sub>OUT</sub> = -50 μA	4.5 5.5	4.49 5.49	4.4 5.4	4.4 5.4	V
		V <sub>IN</sub> = V <sub>IL</sub> or V <sub>IH</sub> I <sub>OH</sub> = -24mA -24 mA	4.5 5.5		3.86 4.86	3.76 4.76	V
V <sub>OL</sub>	Maximum Low Level Output Voltage	I <sub>OUT</sub> = 50 μA	4.5 5.5	0.001 0.001	0.1 0.1	0.1 0.1	V
		V <sub>IN</sub> = V <sub>IL</sub> or V <sub>IH</sub> I <sub>OL</sub> = 24mA 24 mA	4.5 5.5		0.36 0.36	0.44 0.44	V
I <sub>IN</sub>	Maximum Input Leakage Current	V <sub>IN</sub> = V <sub>CC</sub> or GND	5.5		±0.1	±1.0	μA
ΔI <sub>CC</sub> T	Additional Max I <sub>CC</sub> / Input	V <sub>IN</sub> = V <sub>CC</sub> - 2.1 V	5.5	0.6		1.5	mA
I <sub>CC</sub>	Maximum Quiescent Supply Current	V <sub>IN</sub> = V <sub>CC</sub> or GND	5.5		4.0	40	μA

**AC CHARACTERISTICS** over full operating conditions

Symbol	Parameter	V <sub>CC</sub> ±10% (V)	ACT04				Unit
			T <sub>A</sub> = +25°C C <sub>L</sub> = 50 pF		T <sub>A</sub> = -40°C to +85°C C <sub>L</sub> = 50 pF		
			Min	Max	Min	Max	
t <sub>PLH</sub>	Propagation Delay	5.0	1.5	8.5	1.0	9.0	ns
t <sub>PHL</sub>	Propagation Delay	5.0	1.5	8.0	1.0	8.5	ns

**SWITCHING WAVEFORMS**

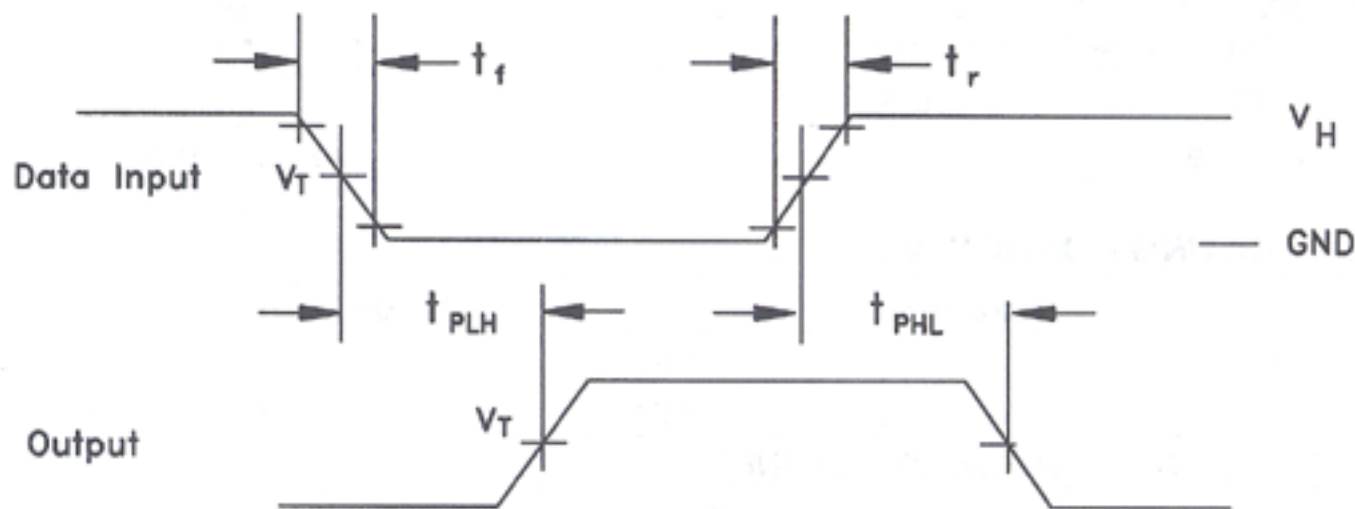

Input and output threshold voltage:  
 V<sub>T</sub> = 50% V<sub>CC</sub> for AC; 1.5V for ACT  
 V<sub>H</sub> = V<sub>CC</sub> for AC, 3V for ACT