

DO NOT SCALE FROM THIS PRINT

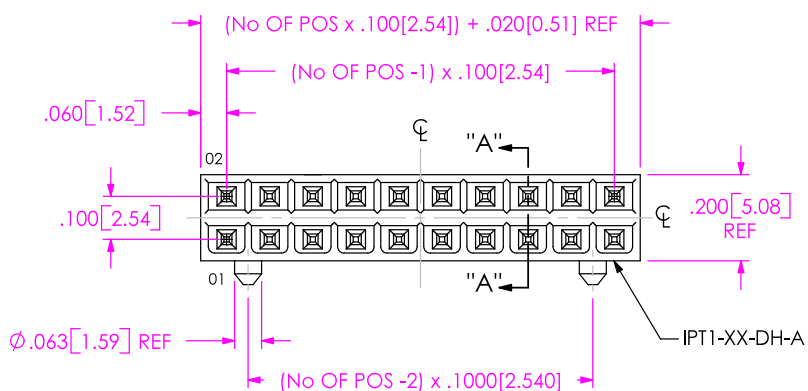
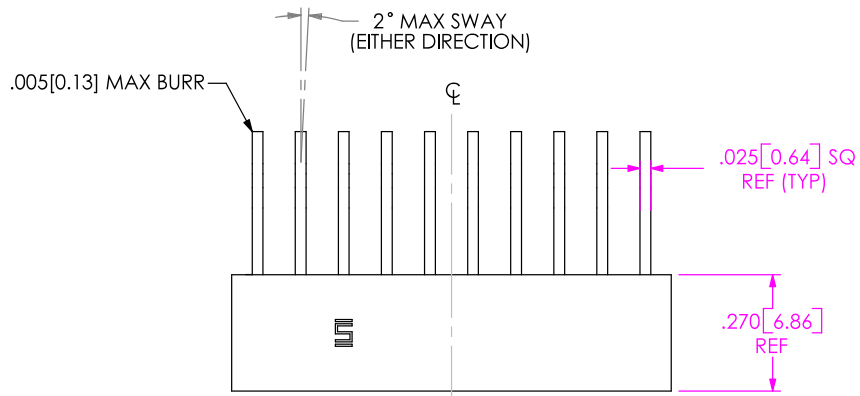

NOTES:

1. C1 REPRESENTS A CRITICAL DIMENSION.
2. NOTE DELETED
3. MINIMUM TERMINAL PUSH OUT FORCE: 2 lbs.
4. MAXIMUM VARIATION BETWEEN PIN ROWS: .005[.13].
5. NOTE DELETED
6. ALL DIMENSIONS TO BE ABOUT CENTERLINE WITHIN +/- .005[.13].
7. NOTE DELETED.
8. PINS TO BE FLUSH TO .101[0.25] BELOW TOP OF SHROUD.
9. SHEAR TAILS TO DIMENSION SHOWN.

FIG. 1
IPT1-110-01-X-D-DH-A SHOWN

IPT1-1XX-XX-X-D-DH-A-XXX

No OF POS PER ROW
-04 THRU -25

LEAD STYLE
-01

PLATING SPECIFICATION

- T: TIN (USE T-1S6-08-T-2 & T-1S6-09-T-2)
- S: SELECTIVE GOLD (USE T-1S6-08-S-2 & T-1S6-09-S-2)
- TM: MATTE TIN TAIL (USE T-1S6-08-T-2 & T-1S6-09-T-2)
- SM: SELECTIVE GOLD, MATTE TIN TAIL (USE T-1S6-08-S-2 & T-1S6-09-S-2)

OPTIONS

- POL: POSITION #1 REMOVED (USE IPT1-XX-DH-P)
- TR: TAPE AND REEL PACKAGING

ALIGNMENT PINS

TAIL OPTION

- DH: DOUBLE HORIZONTAL

ROW SPECIFICATION

- D: DOUBLE (USE IPT1-XX-DH-A)

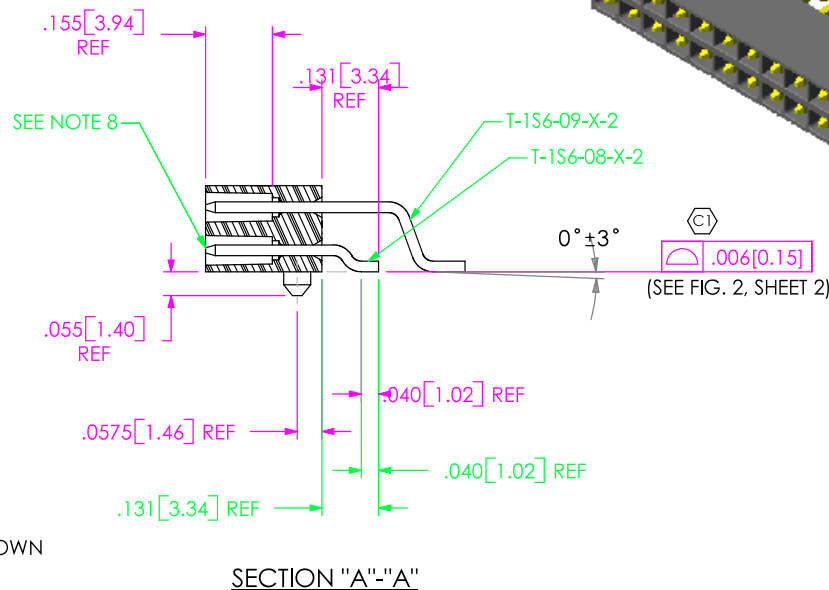
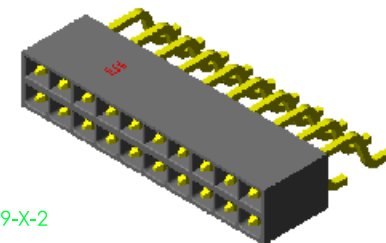

-POL: POLARIZED OPTION
IPT1-110-01-X-D-DH-A-POL SHOWN

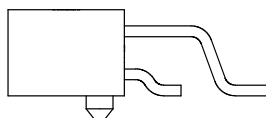
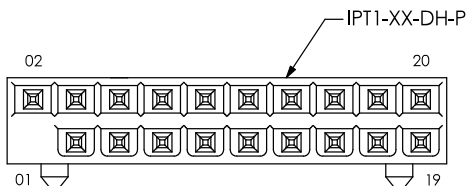

UNLESS OTHERWISE SPECIFIED, DIMENSIONS ARE IN INCHES. TOLERANCES ARE:
DECIMALS .XX: ±.01[.3]
.XXX: ±.005[.13]
.XXXX: ±.0020[.051]

PROPRIETARY NOTE

THIS DOCUMENT CONTAINS INFORMATION CONFIDENTIAL AND PROPRIETARY TO SAMTEC, INC. AND SHALL NOT BE REPRODUCED OR TRANSFERRED TO OTHER DOCUMENTS OR DISCLOSED TO OTHERS OR USED FOR ANY PURPOSE OTHER THAN THAT WHICH IT WAS OBTAINED WITHOUT THE EXPRESSED WRITTEN CONSENT OF SAMTEC, INC.

SAMTEC

520 PARK EAST BLVD, NEW ALBANY, IN 47150
PHONE: 812.944.6733 FAX: 812.948.5047
e-Mail: INFO@SAMTEC.COM CODE: 55322

MATERIAL: DO NOT SCALE DRAWING
INSULATOR: VECTRA E130I, COLOR: BLACK
TERMINAL: PHOS BRONZE, 510, 3/4 HARD

SHEET SCALE: 2.25:1

DESCRIPTION:
.100 DOUBLE ROW, HORIZONTAL SHROUDED TERMINAL ASSM

DWG. NO.
IPT1-1XX-XX-X-D-DH-A-XXX

BY: BRATCHER 11/15/02 SHEET 1 OF 2

IN-PROCESS 1

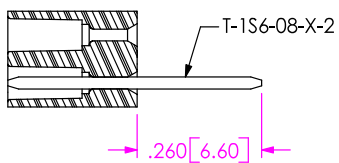

IN-PROCESS 2

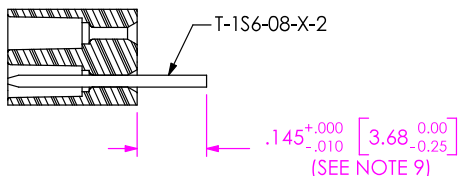

IN-PROCESS 3

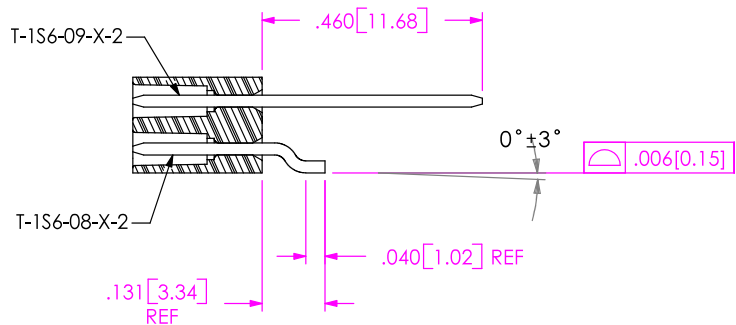

IN-PROCESS 4

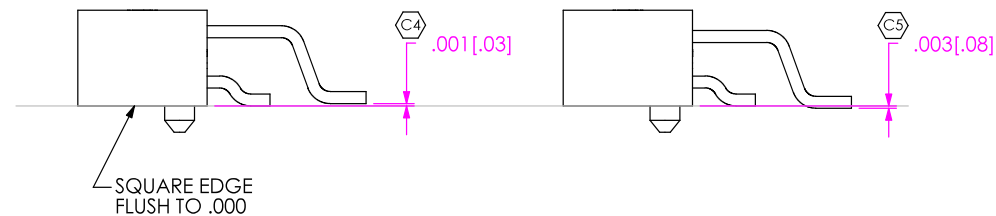
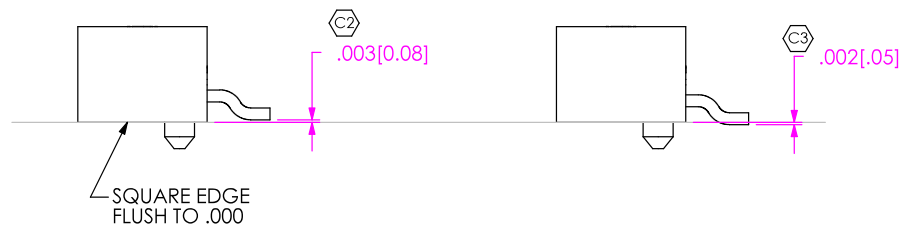
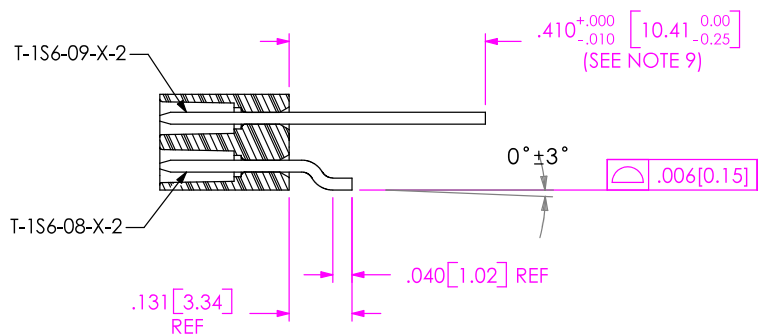
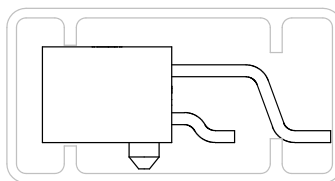

FIG. 2

-DH: SURFACE MOUNT DIAGRAM

PACKAGING VIEW

(PARTS TO HAVE POSITION #1 LOADED IN SAME DIRECTION AS ARROW ON TUBE)



TUBE: PT-1-24-15-29
PLUG: TP-07

F:\DWG\MISC\mktg\IPT1-1XX-XX-X-D-DH-A-XXX-MKT.SLDDRW

PROPRIETARY NOTE

THIS DOCUMENT CONTAINS INFORMATION CONFIDENTIAL AND PROPRIETARY TO SAMTEC, INC. AND SHALL NOT BE REPRODUCED OR TRANSFERRED TO OTHER DOCUMENTS OR DISCLOSED TO OTHERS OR USED FOR ANY PURPOSE OTHER THAN THAT WHICH IT WAS OBTAINED WITHOUT THE EXPRESSED WRITTEN CONSENT OF SAMTEC, INC.

DO NOT SCALE DRAWING

SHEET SCALE: 2.5:1

SAMTEC

520 PARK EAST BLVD, NEW ALBANY, IN 47150
PHONE: 812.944.6733 FAX: 812.948.5047
e-Mail: INFO@SAMTEC.COM CODE: 55322

DESCRIPTION:
.100 DOUBLE ROW, HORIZONTAL SHROUDED TERMINAL ASSM

DWG. NO.
IPT1-1XX-XX-X-D-DH-A-XXX

BY: BRATCHER 11/15/02 SHEET 2 OF 2