

Stacked MCP (Multi-Chip Package) FLASH MEMORY & SRAM
CMOS

**16M (× 8/ × 16) FLASH MEMORY &
4M (× 8/ × 16) STATIC RAM**

MB84VD2118XA-85/MB84VD2119XA-85

■ FEATURES

- Power supply voltage of 2.7 V to 3.6 V
- High performance
85 ns maximum access time
- Operating Temperature
-25 °C to +85 °C
- Package 69-ball FBGA, 56-pin TSOP(I)

(Continued)

■ PRODUCT LINE UP

		Flash Memory	SRAM
Ordering Part No.	$V_{ccf}^*, V_{ccs}^* = 3.0\text{ V}$ ^{+0.6 V} _{-0.3 V}	MB84VD2118XA-85/MB84VD2119XA-85	
Max. Address Access Time (ns)		85	85
Max. \overline{CE} Access Time (ns)		85	85
Max. \overline{OE} Access Time (ns)		35	45

*: Both V_{ccf} and V_{ccs} must be in recommended operation range when either part is being accessed.

■ PACKAGES

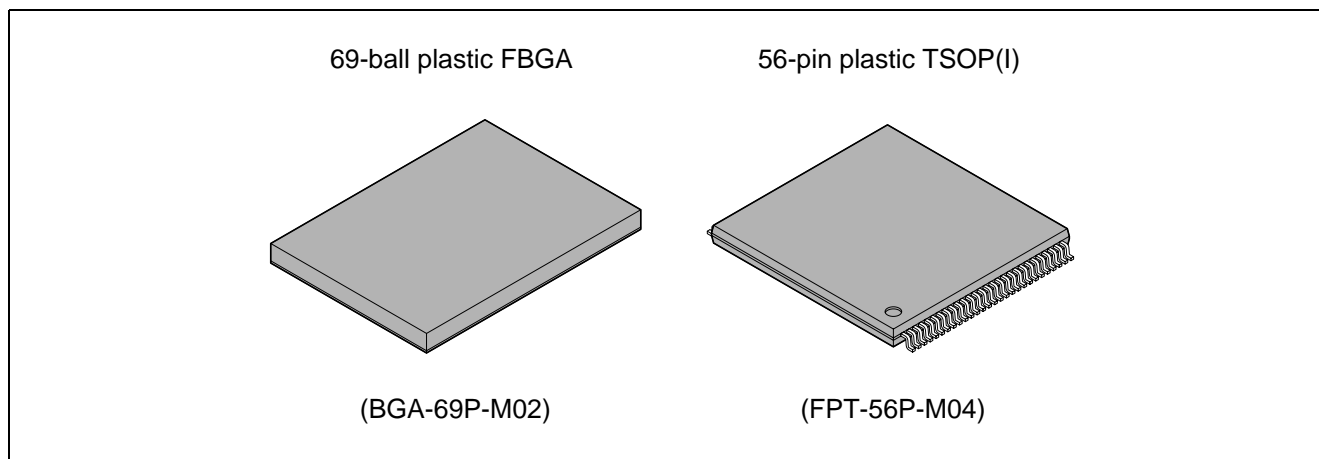

MB84VD2118XA-85/MB84VD2119XA-85

(Continued)

1. FLASH MEMORY

- **Simultaneous Read/Write operations (dual bank)**

Multiple devices available with different bank sizes (Refer to “PIN DESCRIPTION”)

Host system can program or erase in one bank, then immediately and simultaneously read from the other bank

Zero latency between read and write operations

Read-while-erase

Read-while-program

- **Minimum 100,000 write/erase cycles**

- **Sector erase architecture**

Eight 4 K words and thirty one 32 K words.

Any combination of sectors can be concurrently erased. Also supports full chip erase.

- **Boot Code Sector Architecture**

MB84VD2118XA : Top sector

MB84VD2119XA : Bottom sector

- **Embedded Erase™* Algorithms**

Automatically pre-programs and erases the chip or any sector

- **Embedded Program™* Algorithms**

Automatically writes and verifies data at specified address

- **Data Polling and Toggle Bit feature for detection of program or erase cycle completion**

- **Ready-Busy output (RY/BY)**

Hardware method for detection of program or erase cycle completion

- **Automatic sleep mode**

When addresses remain stable, automatically switch themselves to low power mode.

- **Low V_{ccf} write inhibit ≤ 2.5 V**

- **Hidden ROM (Hi-ROM) region**

64K byte of Hi-ROM, accessible through a new “Hi-ROM Enable” command sequence

Factory serialized and protected to provide a secure electronic serial number (ESN)

- **WP/ACC input pin**

At V_{IL}, allows protection of boot sectors, regardless of sector protection/unprotection status

(MB84VD2118XA : SA37, SA38 MB84VD2119XA : SA0, SA1)

At V_{IH}, allows removal of boot sector protection

At V_{ACC}, program time will reduce by 40%.

- **Erase Suspend/Resume**

Suspends the erase operation to allow a read in another sector within the same device

- **Please refer to “MBM29DL16XTD/BD” data sheet in detailed function**

2. SRAM

- **Power dissipation**

Operating : 40 mA Max.

Standby : 7 μA Max.

- **Power down features using $\overline{CE1s}$ and $CE2s$**

- **Data retention supply voltage : 1.5 V to 3.6 V**

- **$\overline{CE1s}$ and $CE2s$ Chip Select**

- **Byte data control : \overline{LBs} (DQ₀ to DQ₇) , \overline{UBs} (DQ₈ to DQ₁₅)**

*: Embedded Erase™ and Embedded Program™ are trademarks of Advanced Micro Devices, Inc.

MB84VD2118XA-85/MB84VD2119XA-85

■ PIN ASSIGNMENTS

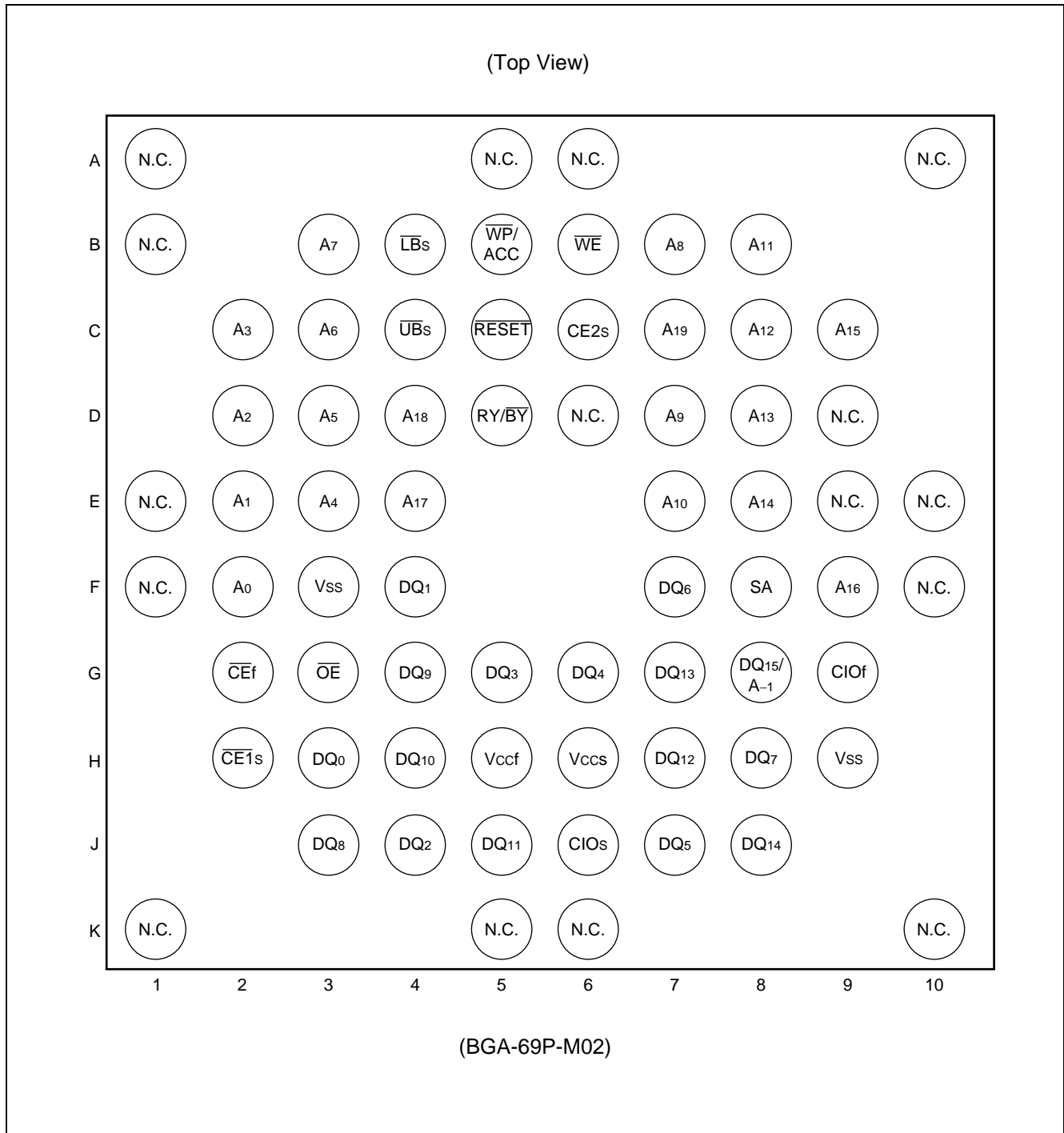

MB84VD2118XA-85/MB84VD2119XA-85

(Top View)

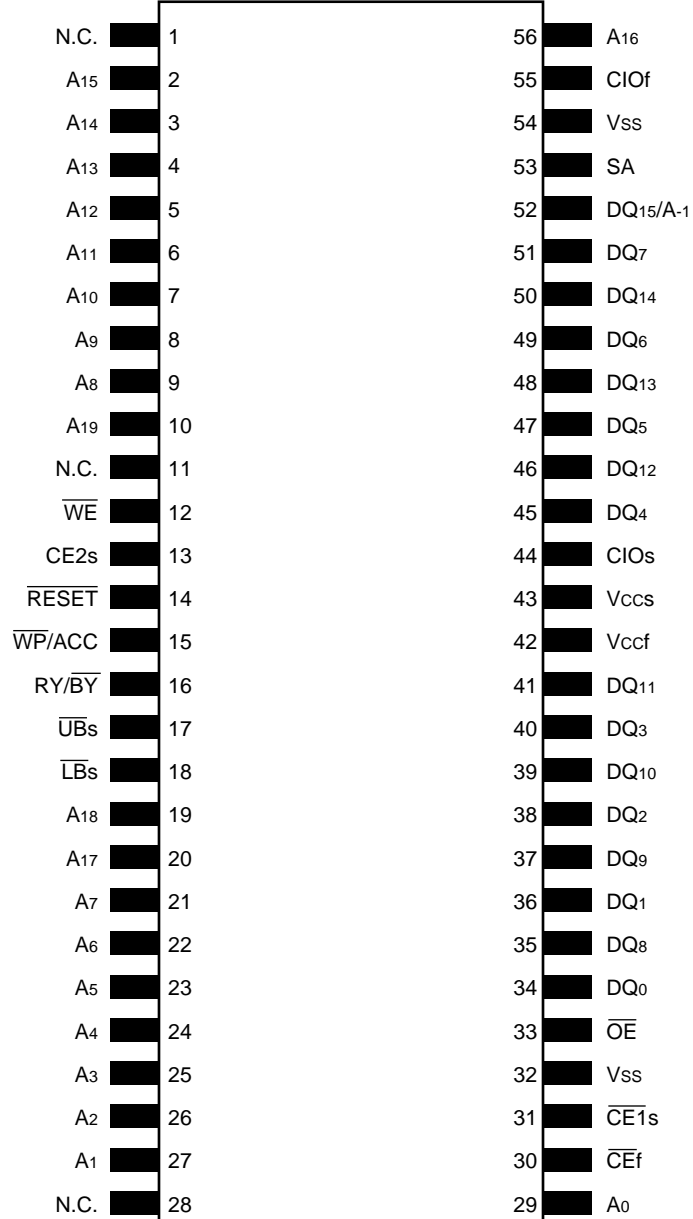

(FPT-56P-M04)

MB84VD2118XA-85/MB84VD2119XA-85

■ PIN DESCRIPTION

Pin name	Function	Input/Output
A ₀ to A ₁₇	Address Inputs (Common)	I
A-1, A ₁₈ , A ₁₉	Address Input (Flash)	I
SA	Address Input (SRAM)	I
DQ ₀ to DQ ₁₅	Data Inputs/Outputs (Common)	I/O
$\overline{\text{CE}}_f$	Chip Enable (Flash)	I
$\overline{\text{CE}}_{1s}$	Chip Enable (SRAM)	I
CE _{2s}	Chip Enable (SRAM)	I
$\overline{\text{OE}}$	Output Enable (Common)	I
$\overline{\text{WE}}$	Write Enable (Common)	I
RY/ $\overline{\text{BY}}$	Ready/Busy Outputs (Flash) Open Drain Output	O
$\overline{\text{UB}}_s$	Upper Byte Control (SRAM)	I
$\overline{\text{LB}}_s$	Lower Byte Control (SRAM)	I
CIO _f	I/O Configuration (Flash) CIO _f = V _{ccf} is Word mode (× 16), CIO _f = V _{ss} is Byte mode (× 8)	I
CIO _s	I/O Configuration (SRAM) CIO _s = V _{ccs} is Word mode (× 16), CIO _s = V _{ss} is Byte mode (× 8)	I
$\overline{\text{RESET}}$	Hardware Reset Pin/Sector Protection Unlock (Flash)	I
$\overline{\text{WP/ACC}}$	Write Protect / Acceleration (Flash)	I
N.C.	No Internal Connection	—
V _{ss}	Device Ground (Common)	Power
V _{ccf}	Device Power Supply (Flash)	Power
V _{ccs}	Device Power Supply (SRAM)	Power

MB84VD2118XA-85/MB84VD2119XA-85

■ BLOCK DIAGRAM

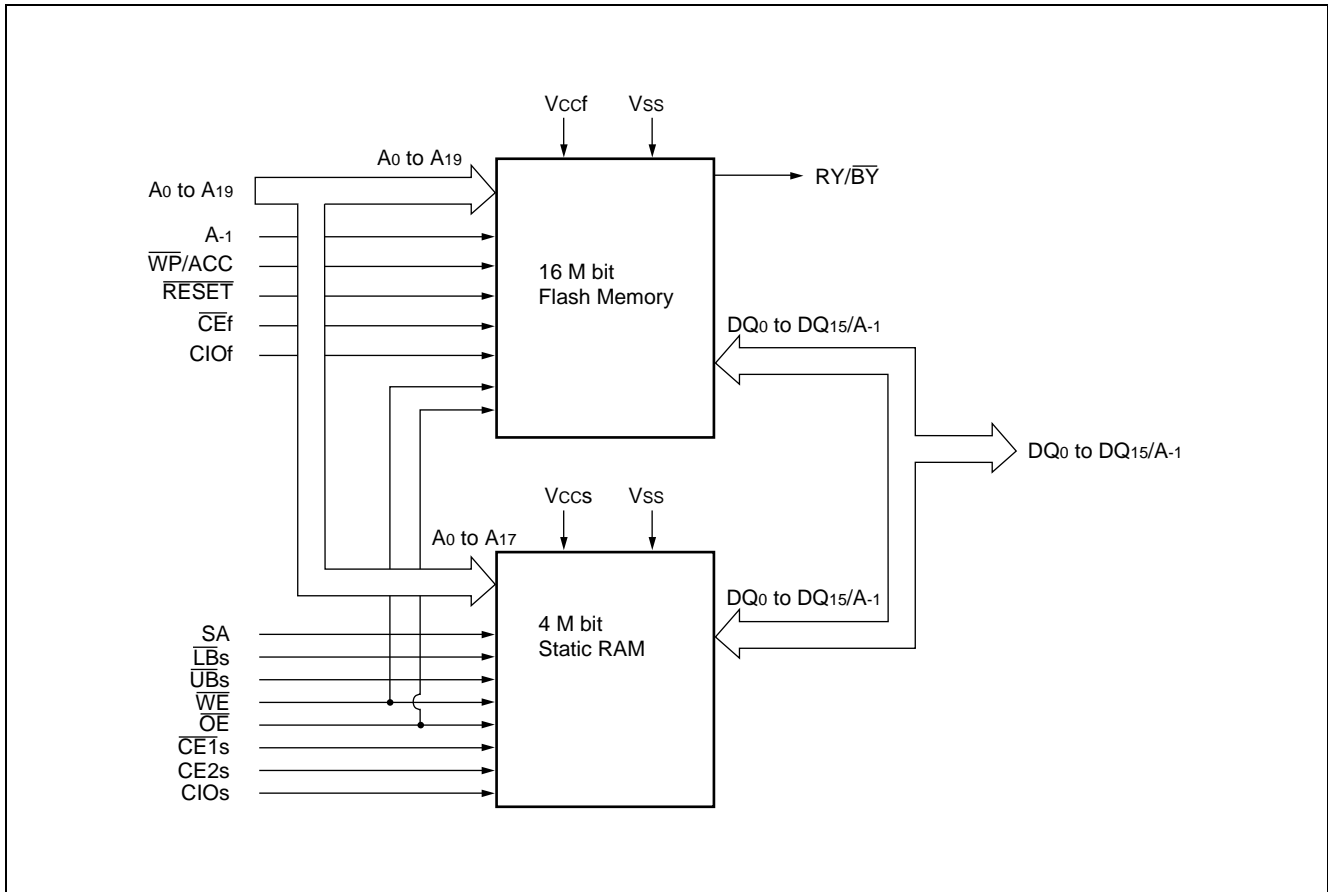

MB84VD2118XA-85/MB84VD2119XA-85

■ DEVICE BUS OPERATIONS

Table 2.1 User Bus Operations (Flash = Word mode; CIO_f = V_{ccf}, SRAM = Word mode; CIO_s = V_{ccs})

Operation *1, *3	\overline{CE}_f	\overline{CE}_{1s}	CE _{2s}	\overline{OE}	\overline{WE}	SA *6	\overline{LB}_s	\overline{UB}_s	DQ ₀ to DQ ₇	DQ ₈ to DQ ₁₅	\overline{RESET}	\overline{WP}/ACC *5
Full Standby	H	H	X	X	X	X	X	X	High-Z	High-Z	H	X
		X	L									
Output Disable	H	L	H	H	H	X	X	X	High-Z	High-Z	H	X
				X	X	X	H	H	High-Z	High-Z		
	L	H	X	H	H	X	X	X	High-Z	High-Z		
		X	L									
Read from Flash *2	L	H	X	L	H	X	X	X	D _{OUT}	D _{OUT}	H	X
		X	L									
Write to Flash	L	H	X	H	L	X	X	X	D _{IN}	D _{IN}	H	X
		X	L									
Read from SRAM	H	L	H	L	H	X	L	L	D _{OUT}	D _{OUT}	H	X
							H	L	High-Z	D _{OUT}		
							L	H	D _{OUT}	High-Z		
Write to SRAM	H	L	H	X	L	X	L	L	D _{IN}	D _{IN}	H	X
							H	L	High-Z	D _{IN}		
							L	H	D _{IN}	High-Z		
Temporary Sector Group Unprotection *4	X	X	X	X	X	X	X	X	X	X	V _{ID}	X
Flash Hardware Reset	X	H	X	X	X	X	X	X	High-Z	High-Z	L	X
		X	L									
Boot Block Sector Write Protection	X	X	X	X	X	X	X	X	X	X	X	L

Legend: L = V_{IL}, H = V_{IH}, X = V_{IL} or V_{IH}. See "ELECTRICAL CHARACTERISTICS 1. DC Characteristics" for voltage levels.

*1: Other operations except for indicated this column are inhibited.

*2: \overline{WE} can be V_{IL} if \overline{OE} is V_{IL}, \overline{OE} at V_{IH} initiates the write operations.

*3: Do not apply $\overline{CE}_f = V_{IL}$, $\overline{CE}_{1s} = V_{IL}$ and CE_{2s} = V_{IH} at a time.

*4: It is also used for the extended sector group protections.

*5: $\overline{WP}/ACC = V_{IL}$; protection of boot sectors.

$\overline{WP}/ACC = V_{IH}$; removal of boot sectors protection.

$\overline{WP}/ACC = V_{ACC}$ (9V) ; Program time will reduce by 40%.

*6: SA; Don't care or Open.

MB84VD2118XA-85/MB84VD2119XA-85

Table 2.2 User Bus Operations (Flash = Word mode; CIO_f = V_{ccf}, SRAM = Byte mode; CIO_s = V_{ss})

Operation *1, *3	$\overline{CE}f$	$\overline{CE}1s$	CE2s	\overline{OE}	\overline{WE}	SA	$\overline{LB}s$ *6	$\overline{UB}s$ *6	DQ ₀ to DQ ₇	DQ ₈ to DQ ₁₅	\overline{RESET}	\overline{WP}/ACC *5
Full Standby	H	H	X	X	X	X	X	X	High-Z	High-Z	H	X
		X	L									
Output Disable	H	L	H	H	H	X	X	X	High-Z	High-Z	H	X
				X	X	X	H	H	High-Z	High-Z		
	L	H	X	H	H	X	X	X	High-Z	High-Z		
		X	L									
Read from Flash *2	L	H	X	L	H	X	X	X	D _{OUT}	D _{OUT}	H	X
		X	L									
Write to Flash	L	H	X	H	L	X	X	X	D _{IN}	D _{IN}	H	X
		X	L									
Read from SRAM	H	L	H	L	H	SA	X	X	D _{OUT}	High-Z	H	X
Write to SRAM	H	L	H	X	L	SA	X	X	D _{IN}	High-Z	H	X
Temporary Sector Group Unprotection *4	X	X	X	X	X	X	X	X	X	X	V _{ID}	X
Flash Hardware Reset	X	H	X	X	X	X	X	X	High-Z	High-Z	L	X
		X	L									
Boot Block Sector Write Protection	X	X	X	X	X	X	X	X	X	X	X	L

Legend: L = V_{IL}, H = V_{IH}, X = V_{IL} or V_{IH}. See "ELECTRICAL CHARACTERISTICS 1. DC Characteristics" for voltage levels.

*1: Other operations except for indicated this column are inhibited.

*2: \overline{WE} can be V_{IL} if \overline{OE} is V_{IL}, \overline{OE} at V_{IH} initiates the write operations.

*3: Do not apply $\overline{CE}f = V_{IL}$, $\overline{CE}1s = V_{IL}$ and CE2s = V_{IH} at a time.

*4: It is also used for the extended sector group protections.

*5: $\overline{WP}/ACC = V_{IL}$; protection of boot sectors.

$\overline{WP}/ACC = V_{IH}$; removal of boot sectors protection.

$\overline{WP}/ACC = V_{ACC}$ (9V) ; Program time will reduce by 40%.

*6: $\overline{LB}s$, $\overline{UB}s$; Don't care or Open.

MB84VD2118XA-85/MB84VD2119XA-85

Table 2.3 User Bus Operations (Flash = Byte mode; CIO_f = V_{SS}, SRAM = Byte mode; CIO_s = V_{SS})

Operation *1, *3	\overline{CEf}	$\overline{CE1s}$	CE2s	DQ ₁ / A-1	\overline{OE}	\overline{WE}	SA	\overline{LBs} *6	\overline{UBs} *6	DQ ₀ to DQ ₇	DQ ₈ to DQ ₁₄	\overline{RESET}	$\overline{WP/ACC}$ *5
Full Standby	H	H	X	X	X	X	X	X	X	High-Z	High-Z	H	X
		X	L										
Output Disable	H	L	H	X	H	H	X	X	X	High-Z	High-Z	H	X
				X	X	X	X	H	H	High-Z	High-Z		
	L	H	X	A-1	H	H	X	X	X	High-Z	High-Z		
		X	L										
Read from Flash *2	L	H	X	A-1	L	H	X	X	X	D _{OUT}	X	H	X
		X	L										
Write to Flash	L	H	X	A-1	H	L	X	X	X	D _{IN}	X	H	X
		X	L										
Read from SRAM	H	L	H	X	L	H	SA	X	X	D _{OUT}	High-Z	H	X
Write to SRAM	H	L	H	X	X	L	SA	X	X	D _{IN}	High-Z	H	X
Temporary Sector Group Unprotection *4	X	X	X	X	X	X	X	X	X	X	X	V _{ID}	X
Flash Hardware Reset	X	H	X	X	X	X	X	X	X	High-Z	High-Z	L	X
		X	L										
Boot Block Sector Write Protection	X	X	X	X	X	X	X	X	X	X	X	X	L

Legend: L = V_{IL}, H = V_{IH}, X = V_{IL} or V_{IH}. See "ELECTRICAL CHARACTERISTICS 1. DC Characteristics" for voltage levels.

*1: Other operations except for indicated this column are inhibited.

*2: \overline{WE} can be V_{IL} if \overline{OE} is V_{IL}, \overline{OE} at V_{IH} initiates the write operations.

*3: Do not apply $\overline{CEf} = V_{IL}$, $\overline{CE1s} = V_{IL}$ and CE2s = V_{IH} at a time.

*4: It is also used for the extended sector group protections.

*5: $\overline{WP/ACC} = V_{IL}$; protection of boot sectors.

$\overline{WP/ACC} = V_{IH}$; removal of boot sectors protection.

$\overline{WP/ACC} = V_{ACC}$ (9V) ; Program time will reduce by 40%.

*6: \overline{LBs} , \overline{UBs} ; Don't care or Open.

MB84VD2118XA-85/MB84VD2119XA-85

■ FLEXIBLE SECTOR-ERASE ARCHITECTURE on FLASH MEMORY

- Eight 4 K words, and thirty one 32 K words.
- Individual-sector, multiple-sector, or bulk-erase capability.

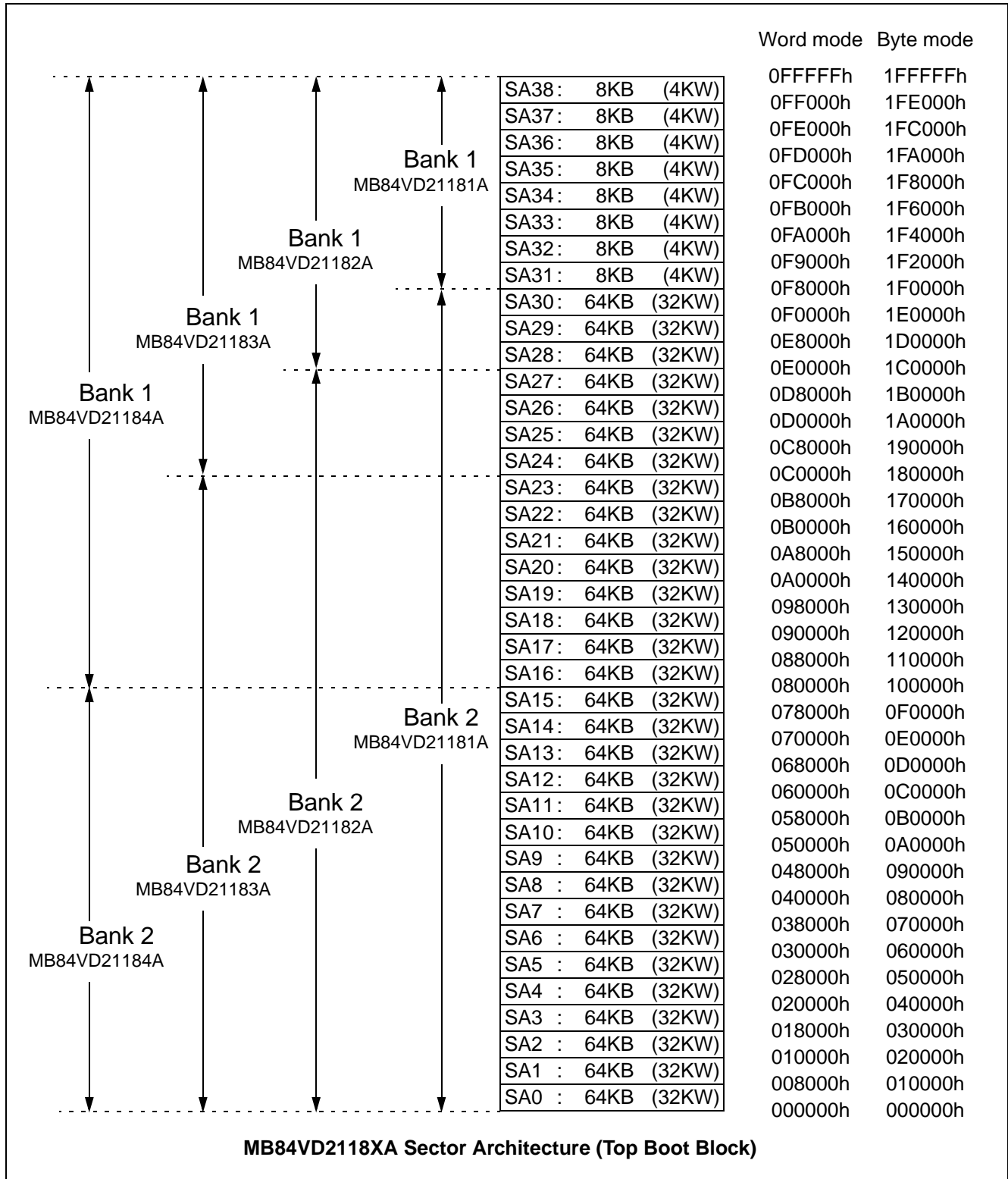

MB84VD2118XA-85/MB84VD2119XA-85

- Eight 4 K words, and thirty one 32 K words.
- Individual-sector, multiple-sector, or bulk-erase capability.

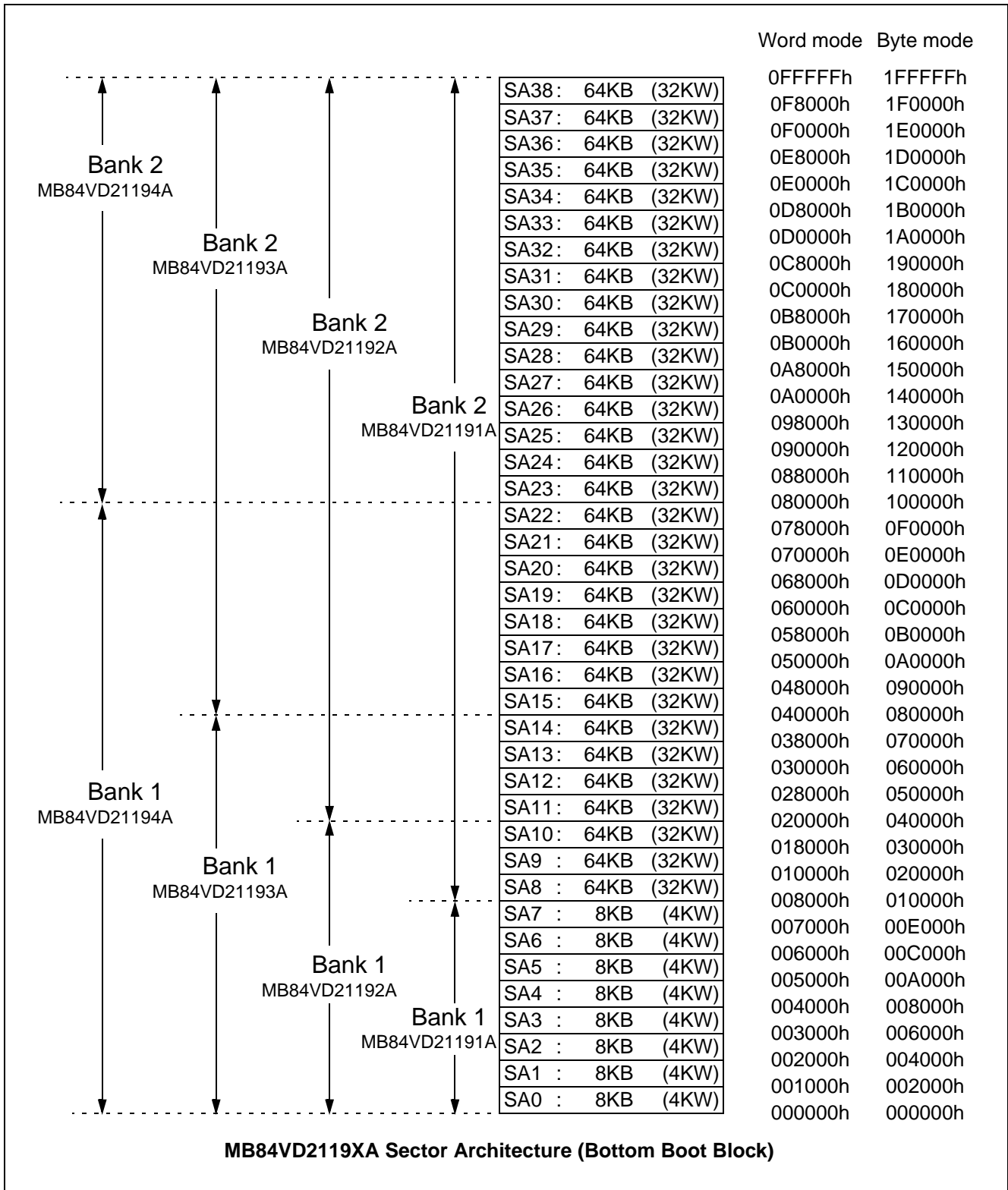

MB84VD2118XA-85/MB84VD2119XA-85

Table 3.1 Sector Address Tables (MB84VD21181)

Bank	Sector	Sector Address								Address Range (Byte mode)	Address Range (Word mode)
		Bank Address									
		A ₁₉	A ₁₈	A ₁₇	A ₁₆	A ₁₅	A ₁₄	A ₁₃	A ₁₂		
Bank 2	SA0	0	0	0	0	0	X	X	X	000000h to 00FFFFh	000000h to 007FFFh
	SA1	0	0	0	0	1	X	X	X	010000h to 01FFFFh	008000h to 00FFFFh
	SA2	0	0	0	1	0	X	X	X	020000h to 02FFFFh	010000h to 017FFFh
	SA3	0	0	0	1	1	X	X	X	030000h to 03FFFFh	018000h to 01FFFFh
	SA4	0	0	1	0	0	X	X	X	040000h to 04FFFFh	020000h to 027FFFh
	SA5	0	0	1	0	1	X	X	X	050000h to 05FFFFh	028000h to 02FFFFh
	SA6	0	0	1	1	0	X	X	X	060000h to 06FFFFh	030000h to 037FFFh
	SA7	0	0	1	1	1	X	X	X	070000h to 07FFFFh	038000h to 03FFFFh
	SA8	0	1	0	0	0	X	X	X	080000h to 08FFFFh	040000h to 047FFFh
	SA9	0	1	0	0	1	X	X	X	090000h to 09FFFFh	048000h to 04FFFFh
	SA10	0	1	0	1	0	X	X	X	0A0000h to 0AFFFFh	050000h to 057FFFh
	SA11	0	1	0	1	1	X	X	X	0B0000h to 0BFFFFh	058000h to 05FFFFh
	SA12	0	1	1	0	0	X	X	X	0C0000h to 0CFFFFh	060000h to 067FFFh
	SA13	0	1	1	0	1	X	X	X	0D0000h to 0DFFFFh	068000h to 06FFFFh
	SA14	0	1	1	1	0	X	X	X	0E0000h to 0EFFFFh	070000h to 077FFFh
	SA15	0	1	1	1	1	X	X	X	0F0000h to 0FFFFFh	078000h to 07FFFFh
	SA16	1	0	0	0	0	X	X	X	100000h to 10FFFFh	080000h to 087FFFh
	SA17	1	0	0	0	1	X	X	X	110000h to 11FFFFh	088000h to 08FFFFh
	SA18	1	0	0	1	0	X	X	X	120000h to 12FFFFh	090000h to 097FFFh
	SA19	1	0	0	1	1	X	X	X	130000h to 13FFFFh	098000h to 09FFFFh
	SA20	1	0	1	0	0	X	X	X	140000h to 14FFFFh	0A0000h to 0A7FFFh
	SA21	1	0	1	0	1	X	X	X	150000h to 15FFFFh	0A8000h to 0AFFFFh
	SA22	1	0	1	1	0	X	X	X	160000h to 16FFFFh	0B0000h to 0B7FFFh
	SA23	1	0	1	1	1	X	X	X	170000h to 17FFFFh	0B8000h to 0BFFFFh
	SA24	1	1	0	0	0	X	X	X	180000h to 18FFFFh	0C0000h to 0C7FFFh
	SA25	1	1	0	0	1	X	X	X	190000h to 19FFFFh	0C8000h to 0CFFFFh
	SA26	1	1	0	1	0	X	X	X	1A0000h to 1AFFFFh	0D0000h to 0D7FFFh
	SA27	1	1	0	1	1	X	X	X	1B0000h to 1BFFFFh	0D8000h to 0DFFFFh
	SA28	1	1	1	0	0	X	X	X	1C0000h to 1CFFFFh	0E0000h to 0E7FFFh
	SA29	1	1	1	0	1	X	X	X	1D0000h to 1DFFFFh	0E8000h to 0EFFFFh
SA30	1	1	1	1	0	X	X	X	1E0000h to 1EFFFFh	0F0000h to 0F7FFFh	
Bank 1	SA31	1	1	1	1	1	0	0	0	1F0000h to 1F1FFFh	0F8000h to 0F8FFFh
	SA32	1	1	1	1	1	0	0	1	1F2000h to 1F3FFFh	0F9000h to 0F9FFFh
	SA33	1	1	1	1	1	0	1	0	1F4000h to 1F5FFFh	0FA000h to 0FAFFFh
	SA34	1	1	1	1	1	0	1	1	1F6000h to 1F7FFFh	0FB000h to 0FBFFFh
	SA35	1	1	1	1	1	1	0	0	1F8000h to 1F9FFFh	0FC000h to 0FCFFFh
	SA36	1	1	1	1	1	1	0	1	1FA000h to 1FBFFFh	0FD000h to 0FDFFFh
	SA37	1	1	1	1	1	1	1	0	1FC000h to 1FDFFFh	0FE000h to 0FEFFFh
	SA38	1	1	1	1	1	1	1	1	1FE000h to 1FFFFFh	0FF000h to 0FFFFFh

MB84VD2118XA-85/MB84VD2119XA-85

Table 3.2 Sector Address Tables (MB84VD21191)

Bank	Sector	Sector Address								Address Range (BYTE mode)	Address Range (WORD mode)
		Bank Address									
		A ₁₉	A ₁₈	A ₁₇	A ₁₆	A ₁₅	A ₁₄	A ₁₃	A ₁₂		
Bank 1	SA0	0	0	0	0	0	0	0	0	000000h to 001FFFh	000000h to 000FFFh
	SA1	0	0	0	0	0	0	0	1	002000h to 003FFFh	001000h to 001FFFh
	SA2	0	0	0	0	0	0	0	1	004000h to 005FFFh	002000h to 002FFFh
	SA3	0	0	0	0	0	0	0	1	006000h to 007FFFh	003000h to 003FFFh
	SA4	0	0	0	0	0	1	0	0	008000h to 009FFFh	004000h to 004FFFh
	SA5	0	0	0	0	0	1	0	1	00A000h to 00BFFFh	005000h to 005FFFh
	SA6	0	0	0	0	0	1	1	0	00C000h to 00DFFFh	006000h to 006FFFh
	SA7	0	0	0	0	0	1	1	1	00E000h to 00FFFFh	007000h to 007FFFh
Bank 2	SA8	0	0	0	0	1	X	X	X	010000h to 01FFFFh	008000h to 00FFFFh
	SA9	0	0	0	1	0	X	X	X	020000h to 02FFFFh	010000h to 017FFFh
	SA10	0	0	0	1	1	X	X	X	030000h to 03FFFFh	018000h to 01FFFFh
	SA11	0	0	1	0	0	X	X	X	040000h to 04FFFFh	020000h to 027FFFh
	SA12	0	0	1	0	1	X	X	X	050000h to 05FFFFh	028000h to 02FFFFh
	SA13	0	0	1	1	0	X	X	X	060000h to 06FFFFh	030000h to 037FFFh
	SA14	0	0	1	1	1	X	X	X	070000h to 07FFFFh	038000h to 03FFFFh
	SA15	0	1	0	0	0	X	X	X	080000h to 08FFFFh	040000h to 047FFFh
	SA16	0	1	0	0	1	X	X	X	090000h to 09FFFFh	048000h to 04FFFFh
	SA17	0	1	0	1	0	X	X	X	0A0000h to 0AFFFFh	050000h to 057FFFh
	SA18	0	1	0	1	1	X	X	X	0B0000h to 0BFFFFh	058000h to 05FFFFh
	SA19	0	1	1	0	0	X	X	X	0C0000h to 0CFFFFh	060000h to 067FFFh
	SA20	0	1	1	0	1	X	X	X	0D0000h to 0DFFFFh	068000h to 06FFFFh
	SA21	0	1	1	1	0	X	X	X	0E0000h to 0EFFFFh	070000h to 077FFFh
	SA22	0	1	1	1	1	X	X	X	0F0000h to 0FFFFFh	078000h to 07FFFFh
	SA23	1	0	0	0	0	X	X	X	100000h to 10FFFFh	080000h to 087FFFh
	SA24	1	0	0	0	1	X	X	X	110000h to 11FFFFh	088000h to 08FFFFh
	SA25	1	0	0	1	0	X	X	X	120000h to 12FFFFh	090000h to 097FFFh
	SA26	1	0	0	1	1	X	X	X	130000h to 13FFFFh	098000h to 09FFFFh
	SA27	1	0	1	0	0	X	X	X	140000h to 14FFFFh	0A0000h to 0A7FFFh
	SA28	1	0	1	0	1	X	X	X	150000h to 15FFFFh	0A8000h to 0AFFFFh
	SA29	1	0	1	1	0	X	X	X	160000h to 16FFFFh	0B0000h to 0B7FFFh
	SA30	1	0	1	1	1	X	X	X	170000h to 17FFFFh	0B8000h to 0BFFFFh
	SA31	1	1	0	0	0	X	X	X	180000h to 18FFFFh	0C0000h to 0C7FFFh
	SA32	1	1	0	0	1	X	X	X	190000h to 19FFFFh	0C8000h to 0CFFFFh
	SA33	1	1	0	1	0	X	X	X	1A0000h to 1AFFFFh	0D0000h to 0D7FFFh
	SA34	1	1	0	1	1	X	X	X	1B0000h to 1BFFFFh	0D8000h to 0DFFFFh
	SA35	1	1	1	0	0	X	X	X	1C0000h to 1CFFFFh	0E0000h to 0E7FFFh
	SA36	1	1	1	0	1	X	X	X	1D0000h to 1DFFFFh	0E8000h to 0EFFFFh
	SA37	1	1	1	1	0	X	X	X	1E0000h to 1EFFFFh	0F0000h to 0F7FFFh
SA38	1	1	1	1	1	X	X	X	1F0000h to 1FFFFFh	0F8000h to 0FFFFFh	

MB84VD2118XA-85/MB84VD2119XA-85

Table 3.3 Sector Address Tables (MB84VD21182)

Bank	Sector	Sector Address								Address Range (BYTE mode)	Address Range (WORD mode)
		Bank Address									
		A ₁₉	A ₁₈	A ₁₇	A ₁₆	A ₁₅	A ₁₄	A ₁₃	A ₁₂		
Bank 2	SA0	0	0	0	0	0	X	X	X	000000h to 00FFFFh	000000h to 007FFFh
	SA1	0	0	0	0	1	X	X	X	010000h to 01FFFFh	008000h to 00FFFFh
	SA2	0	0	0	1	0	X	X	X	020000h to 02FFFFh	010000h to 017FFFh
	SA3	0	0	0	1	1	X	X	X	030000h to 03FFFFh	018000h to 01FFFFh
	SA4	0	0	1	0	0	X	X	X	040000h to 04FFFFh	020000h to 027FFFh
	SA5	0	0	1	0	1	X	X	X	050000h to 05FFFFh	028000h to 02FFFFh
	SA6	0	0	1	1	0	X	X	X	060000h to 06FFFFh	030000h to 037FFFh
	SA7	0	0	1	1	1	X	X	X	070000h to 07FFFFh	038000h to 03FFFFh
	SA8	0	1	0	0	0	X	X	X	080000h to 08FFFFh	040000h to 047FFFh
	SA9	0	1	0	0	1	X	X	X	090000h to 09FFFFh	048000h to 04FFFFh
	SA10	0	1	0	1	0	X	X	X	0A0000h to 0AFFFFh	050000h to 057FFFh
	SA11	0	1	0	1	1	X	X	X	0B0000h to 0BFFFFh	058000h to 05FFFFh
	SA12	0	1	1	0	0	X	X	X	0C0000h to 0CFFFFh	060000h to 067FFFh
	SA13	0	1	1	0	1	X	X	X	0D0000h to 0DFFFFh	068000h to 06FFFFh
	SA14	0	1	1	1	0	X	X	X	0E0000h to 0EFFFFh	070000h to 077FFFh
	SA15	0	1	1	1	1	X	X	X	0F0000h to 0FFFFFFh	078000h to 07FFFFh
	SA16	1	0	0	0	0	X	X	X	100000h to 10FFFFh	080000h to 087FFFh
	SA17	1	0	0	0	1	X	X	X	110000h to 11FFFFh	088000h to 08FFFFh
	SA18	1	0	0	1	0	X	X	X	120000h to 12FFFFh	090000h to 097FFFh
	SA19	1	0	0	1	1	X	X	X	130000h to 13FFFFh	098000h to 09FFFFh
	SA20	1	0	1	0	0	X	X	X	140000h to 14FFFFh	0A0000h to 0A7FFFh
	SA21	1	0	1	0	1	X	X	X	150000h to 15FFFFh	0A8000h to 0AFFFFh
	SA22	1	0	1	1	0	X	X	X	160000h to 16FFFFh	0B0000h to 0B7FFFh
	SA23	1	0	1	1	1	X	X	X	170000h to 17FFFFh	0B8000h to 0BFFFFh
	SA24	1	1	0	0	0	X	X	X	180000h to 18FFFFh	0C0000h to 0C7FFFh
	SA25	1	1	0	0	1	X	X	X	190000h to 19FFFFh	0C8000h to 0CFFFFh
	SA26	1	1	0	1	0	X	X	X	1A0000h to 1AFFFFh	0D0000h to 0D7FFFh
SA27	1	1	0	1	1	X	X	X	1B0000h to 1BFFFFh	0D8000h to 0DFFFFh	
Bank 1	SA28	1	1	1	0	0	X	X	X	1C0000h to 1CFFFFh	0E0000h to 0E7FFFh
	SA29	1	1	1	0	1	X	X	X	1D0000h to 1DFFFFh	0E8000h to 0EFFFFh
	SA30	1	1	1	1	0	X	X	X	1E0000h to 1EFFFFh	0F0000h to 0F7FFFh
	SA31	1	1	1	1	1	0	0	0	1F0000h to 1F1FFFh	0F8000h to 0F8FFFh
	SA32	1	1	1	1	1	0	0	1	1F2000h to 1F3FFFh	0F9000h to 0F9FFFh
	SA33	1	1	1	1	1	0	1	0	1F4000h to 1F5FFFh	0FA000h to 0FAFFFh
	SA34	1	1	1	1	1	0	1	1	1F6000h to 1F7FFFh	0FB000h to 0FBFFFh
	SA35	1	1	1	1	1	1	0	0	1F8000h to 1F9FFFh	0FC000h to 0FCFFFh
	SA36	1	1	1	1	1	1	0	1	1FA000h to 1FBFFFh	0FD000h to 0FDFFFh
	SA37	1	1	1	1	1	1	1	0	1FC000h to 1FDFFFh	0FE000h to 0FEFFFh
	SA38	1	1	1	1	1	1	1	1	1FE000h to 1FFFFFFh	0FF000h to 0FFFFFFh

MB84VD2118XA-85/MB84VD2119XA-85

Table 3.4 Sector Address Tables (MB84VD21192)

Bank	Sector	Sector Address								Address Range (BYTE mode)	Address Range (WORD mode)
		Bank Address									
		A ₁₉	A ₁₈	A ₁₇	A ₁₆	A ₁₅	A ₁₄	A ₁₃	A ₁₂		
Bank 1	SA0	0	0	0	0	0	0	0	0	000000h to 001FFFh	000000h to 000FFFh
	SA1	0	0	0	0	0	0	0	1	002000h to 003FFFh	001000h to 001FFFh
	SA2	0	0	0	0	0	0	0	1	004000h to 005FFFh	002000h to 002FFFh
	SA3	0	0	0	0	0	0	0	1	006000h to 007FFFh	003000h to 003FFFh
	SA4	0	0	0	0	0	1	0	0	008000h to 009FFFh	004000h to 004FFFh
	SA5	0	0	0	0	0	1	0	1	00A000h to 00BFFFh	005000h to 005FFFh
	SA6	0	0	0	0	0	1	1	0	00C000h to 00DFFFh	006000h to 006FFFh
	SA7	0	0	0	0	0	1	1	1	00E000h to 00FFFFh	007000h to 007FFFh
	SA8	0	0	0	0	1	X	X	X	010000h to 01FFFFh	008000h to 00FFFFh
	SA9	0	0	0	1	0	X	X	X	020000h to 02FFFFh	010000h to 017FFFh
Bank 2	SA10	0	0	0	1	1	X	X	X	030000h to 03FFFFh	018000h to 01FFFFh
	SA11	0	0	1	0	0	X	X	X	040000h to 04FFFFh	020000h to 027FFFh
	SA12	0	0	1	0	1	X	X	X	050000h to 05FFFFh	028000h to 02FFFFh
	SA13	0	0	1	1	0	X	X	X	060000h to 06FFFFh	030000h to 037FFFh
	SA14	0	0	1	1	1	X	X	X	070000h to 07FFFFh	038000h to 03FFFFh
	SA15	0	1	0	0	0	X	X	X	080000h to 08FFFFh	040000h to 047FFFh
	SA16	0	1	0	0	1	X	X	X	090000h to 09FFFFh	048000h to 04FFFFh
	SA17	0	1	0	1	0	X	X	X	0A0000h to 0AFFFFh	050000h to 057FFFh
	SA18	0	1	0	1	1	X	X	X	0B0000h to 0BFFFFh	058000h to 05FFFFh
	SA19	0	1	1	0	0	X	X	X	0C0000h to 0CFFFFh	060000h to 067FFFh
	SA20	0	1	1	0	1	X	X	X	0D0000h to 0DFFFFh	068000h to 06FFFFh
	SA21	0	1	1	1	0	X	X	X	0E0000h to 0EFFFFh	070000h to 077FFFh
	SA22	0	1	1	1	1	X	X	X	0F0000h to 0FFFFFh	078000h to 07FFFFh
	SA23	1	0	0	0	0	X	X	X	100000h to 10FFFFh	080000h to 087FFFh
	SA24	1	0	0	0	1	X	X	X	110000h to 11FFFFh	088000h to 08FFFFh
	SA25	1	0	0	1	0	X	X	X	120000h to 12FFFFh	090000h to 097FFFh
	SA26	1	0	0	1	1	X	X	X	130000h to 13FFFFh	098000h to 09FFFFh
	SA27	1	0	1	0	0	X	X	X	140000h to 14FFFFh	0A0000h to 0A7FFFh
	SA28	1	0	1	0	1	X	X	X	150000h to 15FFFFh	0A8000h to 0AFFFFh
	SA29	1	0	1	1	0	X	X	X	160000h to 16FFFFh	0B0000h to 0B7FFFh
	SA30	1	0	1	1	1	X	X	X	170000h to 17FFFFh	0B8000h to 0BFFFFh
	SA31	1	1	0	0	0	X	X	X	180000h to 18FFFFh	0C0000h to 0C7FFFh
	SA32	1	1	0	0	1	X	X	X	190000h to 19FFFFh	0C8000h to 0CFFFFh
	SA33	1	1	0	1	0	X	X	X	1A0000h to 1AFFFFh	0D0000h to 0D7FFFh
	SA34	1	1	0	1	1	X	X	X	1B0000h to 1BFFFFh	0D8000h to 0DFFFFh
	SA35	1	1	1	0	0	X	X	X	1C0000h to 1CFFFFh	0E0000h to 0E7FFFh
	SA36	1	1	1	0	1	X	X	X	1D0000h to 1DFFFFh	0E8000h to 0EFFFFh
	SA37	1	1	1	1	0	X	X	X	1E0000h to 1EFFFFh	0F0000h to 0F7FFFh
SA38	1	1	1	1	1	X	X	X	1F0000h to 1FFFFFh	0F8000h to 0FFFFFh	

MB84VD2118XA-85/MB84VD2119XA-85

Table 3.5 Sector Address Tables (MB84VD21183)

Bank	Sector	Sector Address								Address Range (BYTE mode)	Address Range (WORD mode)
		Bank Address									
		A ₁₉	A ₁₈	A ₁₇	A ₁₆	A ₁₅	A ₁₄	A ₁₃	A ₁₂		
Bank 2	SA0	0	0	0	0	0	X	X	X	000000h to 00FFFFh	000000h to 007FFFh
	SA1	0	0	0	0	1	X	X	X	010000h to 01FFFFh	008000h to 00FFFFh
	SA2	0	0	0	1	0	X	X	X	020000h to 02FFFFh	010000h to 017FFFh
	SA3	0	0	0	1	1	X	X	X	030000h to 03FFFFh	018000h to 01FFFFh
	SA4	0	0	1	0	0	X	X	X	040000h to 04FFFFh	020000h to 027FFFh
	SA5	0	0	1	0	1	X	X	X	050000h to 05FFFFh	028000h to 02FFFFh
	SA6	0	0	1	1	0	X	X	X	060000h to 06FFFFh	030000h to 037FFFh
	SA7	0	0	1	1	1	X	X	X	070000h to 07FFFFh	038000h to 03FFFFh
	SA8	0	1	0	0	0	X	X	X	080000h to 08FFFFh	040000h to 047FFFh
	SA9	0	1	0	0	1	X	X	X	090000h to 09FFFFh	048000h to 04FFFFh
	SA10	0	1	0	1	0	X	X	X	0A0000h to 0AFFFFh	050000h to 057FFFh
	SA11	0	1	0	1	1	X	X	X	0B0000h to 0BFFFFh	058000h to 05FFFFh
	SA12	0	1	1	0	0	X	X	X	0C0000h to 0CFFFFh	060000h to 067FFFh
	SA13	0	1	1	0	1	X	X	X	0D0000h to 0DFFFFh	068000h to 06FFFFh
	SA14	0	1	1	1	0	X	X	X	0E0000h to 0EFFFFh	070000h to 077FFFh
	SA15	0	1	1	1	1	X	X	X	0F0000h to 0FFFFFh	078000h to 07FFFFh
	SA16	1	0	0	0	0	X	X	X	100000h to 10FFFFh	080000h to 087FFFh
	SA17	1	0	0	0	1	X	X	X	110000h to 11FFFFh	088000h to 08FFFFh
	SA18	1	0	0	1	0	X	X	X	120000h to 12FFFFh	090000h to 097FFFh
	SA19	1	0	0	1	1	X	X	X	130000h to 13FFFFh	098000h to 09FFFFh
	SA20	1	0	1	0	0	X	X	X	140000h to 14FFFFh	0A0000h to 0A7FFFh
	SA21	1	0	1	0	1	X	X	X	150000h to 15FFFFh	0A8000h to 0AFFFFh
	SA22	1	0	1	1	0	X	X	X	160000h to 16FFFFh	0B0000h to 0B7FFFh
SA23	1	0	1	1	1	X	X	X	170000h to 17FFFFh	0B8000h to 0BFFFFh	
Bank 1	SA24	1	1	0	0	0	X	X	X	180000h to 18FFFFh	0C0000h to 0C7FFFh
	SA25	1	1	0	0	1	X	X	X	190000h to 19FFFFh	0C8000h to 0CFFFFh
	SA26	1	1	0	1	0	X	X	X	1A0000h to 1AFFFFh	0D0000h to 0D7FFFh
	SA27	1	1	0	1	1	X	X	X	1B0000h to 1BFFFFh	0D8000h to 0DFFFFh
	SA28	1	1	1	0	0	X	X	X	1C0000h to 1CFFFFh	0E0000h to 0E7FFFh
	SA29	1	1	1	0	1	X	X	X	1D0000h to 1DFFFFh	0E8000h to 0EFFFFh
	SA30	1	1	1	1	0	X	X	X	1E0000h to 1EFFFFh	0F0000h to 0F7FFFh
	SA31	1	1	1	1	1	0	0	0	1F0000h to 1F1FFFh	0F8000h to 0F8FFFh
	SA32	1	1	1	1	1	0	0	1	1F2000h to 1F3FFFh	0F9000h to 0F9FFFh
	SA33	1	1	1	1	1	0	1	0	1F4000h to 1F5FFFh	0FA000h to 0FAFFFh
	SA34	1	1	1	1	1	0	1	1	1F6000h to 1F7FFFh	0FB000h to 0FBFFFh
	SA35	1	1	1	1	1	1	0	0	1F8000h to 1F9FFFh	0FC000h to 0FCFFFh
	SA36	1	1	1	1	1	1	0	1	1FA000h to 1FBFFFh	0FD000h to 0FDFFFh
	SA37	1	1	1	1	1	1	1	0	1FC000h to 1FDFFFh	0FE000h to 0FEFFFh
	SA38	1	1	1	1	1	1	1	1	1FE000h to 1FFFFFh	0FF000h to 0FFFFFh

MB84VD2118XA-85/MB84VD2119XA-85

Table 3.6 Sector Address Tables (MB84VD21193)

Bank	Sector	Sector Address								Address Range (BYTE mode)	Address Range (WORD mode)
		Bank Address									
		A ₁₉	A ₁₈	A ₁₇	A ₁₆	A ₁₅	A ₁₄	A ₁₃	A ₁₂		
Bank 1	SA0	0	0	0	0	0	0	0	0	000000h to 001FFFh	000000h to 000FFFh
	SA1	0	0	0	0	0	0	0	1	002000h to 003FFFh	001000h to 001FFFh
	SA2	0	0	0	0	0	0	0	1	004000h to 005FFFh	002000h to 002FFFh
	SA3	0	0	0	0	0	0	0	1	006000h to 007FFFh	003000h to 003FFFh
	SA4	0	0	0	0	0	1	0	0	008000h to 009FFFh	004000h to 004FFFh
	SA5	0	0	0	0	0	1	0	1	00A000h to 00BFFFh	005000h to 005FFFh
	SA6	0	0	0	0	0	1	1	0	00C000h to 00DFFFh	006000h to 006FFFh
	SA7	0	0	0	0	0	1	1	1	00E000h to 00FFFFh	007000h to 007FFFh
	SA8	0	0	0	0	1	X	X	X	010000h to 01FFFFh	008000h to 00FFFFh
	SA9	0	0	0	1	0	X	X	X	020000h to 02FFFFh	010000h to 017FFFh
	SA10	0	0	0	1	1	X	X	X	030000h to 03FFFFh	018000h to 01FFFFh
	SA11	0	0	1	0	0	X	X	X	040000h to 04FFFFh	020000h to 027FFFh
	SA12	0	0	1	0	1	X	X	X	050000h to 05FFFFh	028000h to 02FFFFh
	SA13	0	0	1	1	0	X	X	X	060000h to 06FFFFh	030000h to 037FFFh
SA14	0	0	1	1	1	X	X	X	070000h to 07FFFFh	038000h to 03FFFFh	
Bank 2	SA15	0	1	0	0	0	X	X	X	080000h to 08FFFFh	040000h to 047FFFh
	SA16	0	1	0	0	1	X	X	X	090000h to 09FFFFh	048000h to 04FFFFh
	SA17	0	1	0	1	0	X	X	X	0A0000h to 0AFFFFh	050000h to 057FFFh
	SA18	0	1	0	1	1	X	X	X	0B0000h to 0BFFFFh	058000h to 05FFFFh
	SA19	0	1	1	0	0	X	X	X	0C0000h to 0CFFFFh	060000h to 067FFFh
	SA20	0	1	1	0	1	X	X	X	0D0000h to 0DFFFFh	068000h to 06FFFFh
	SA21	0	1	1	1	0	X	X	X	0E0000h to 0EFFFFh	070000h to 077FFFh
	SA22	0	1	1	1	1	X	X	X	0F0000h to 0FFFFFh	078000h to 07FFFFh
	SA23	1	0	0	0	0	X	X	X	100000h to 10FFFFh	080000h to 087FFFh
	SA24	1	0	0	0	1	X	X	X	110000h to 11FFFFh	088000h to 08FFFFh
	SA25	1	0	0	1	0	X	X	X	120000h to 12FFFFh	090000h to 097FFFh
	SA26	1	0	0	1	1	X	X	X	130000h to 13FFFFh	098000h to 09FFFFh
	SA27	1	0	1	0	0	X	X	X	140000h to 14FFFFh	0A0000h to 0A7FFFh
	SA28	1	0	1	0	1	X	X	X	150000h to 15FFFFh	0A8000h to 0AFFFFh
	SA29	1	0	1	1	0	X	X	X	160000h to 16FFFFh	0B0000h to 0B7FFFh
	SA30	1	0	1	1	1	X	X	X	170000h to 17FFFFh	0B8000h to 0BFFFFh
	SA31	1	1	0	0	0	X	X	X	180000h to 18FFFFh	0C0000h to 0C7FFFh
	SA32	1	1	0	0	1	X	X	X	190000h to 19FFFFh	0C8000h to 0CFFFFh
	SA33	1	1	0	1	0	X	X	X	1A0000h to 1AFFFFh	0D0000h to 0D7FFFh
	SA34	1	1	0	1	1	X	X	X	1B0000h to 1BFFFFh	0D8000h to 0DFFFFh
	SA35	1	1	1	0	0	X	X	X	1C0000h to 1CFFFFh	0E0000h to 0E7FFFh
	SA36	1	1	1	0	1	X	X	X	1D0000h to 1DFFFFh	0E8000h to 0EFFFFh
	SA37	1	1	1	1	0	X	X	X	1E0000h to 1EFFFFh	0F0000h to 0F7FFFh
	SA38	1	1	1	1	1	X	X	X	1F0000h to 1FFFFFh	0F8000h to 0FFFFFh

MB84VD2118XA-85/MB84VD2119XA-85

Table 3.7 Sector Address Tables (MB84VD21184)

Bank	Sector	Sector Address								Address Range (BYTE mode)	Address Range (WORD mode)
		Bank Address									
		A ₁₉	A ₁₈	A ₁₇	A ₁₆	A ₁₅	A ₁₄	A ₁₃	A ₁₂		
Bank 2	SA0	0	0	0	0	0	X	X	X	000000h to 00FFFFh	000000h to 007FFFh
	SA1	0	0	0	0	1	X	X	X	010000h to 01FFFFh	008000h to 00FFFFh
	SA2	0	0	0	1	0	X	X	X	020000h to 02FFFFh	010000h to 017FFFh
	SA3	0	0	0	1	1	X	X	X	030000h to 03FFFFh	018000h to 01FFFFh
	SA4	0	0	1	0	0	X	X	X	040000h to 04FFFFh	020000h to 027FFFh
	SA5	0	0	1	0	1	X	X	X	050000h to 05FFFFh	028000h to 02FFFFh
	SA6	0	0	1	1	0	X	X	X	060000h to 06FFFFh	030000h to 037FFFh
	SA7	0	0	1	1	1	X	X	X	070000h to 07FFFFh	038000h to 03FFFFh
	SA8	0	1	0	0	0	X	X	X	080000h to 08FFFFh	040000h to 047FFFh
	SA9	0	1	0	0	1	X	X	X	090000h to 09FFFFh	048000h to 04FFFFh
	SA10	0	1	0	1	0	X	X	X	0A0000h to 0AFFFFh	050000h to 057FFFh
	SA11	0	1	0	1	1	X	X	X	0B0000h to 0BFFFFh	058000h to 05FFFFh
	SA12	0	1	1	0	0	X	X	X	0C0000h to 0CFFFFh	060000h to 067FFFh
	SA13	0	1	1	0	1	X	X	X	0D0000h to 0DFFFFh	068000h to 06FFFFh
	SA14	0	1	1	1	0	X	X	X	0E0000h to 0EFFFFh	070000h to 077FFFh
SA15	0	1	1	1	1	X	X	X	0F0000h to 0FFFFFh	078000h to 07FFFFh	
Bank 1	SA16	1	0	0	0	0	X	X	X	100000h to 10FFFFh	080000h to 087FFFh
	SA17	1	0	0	0	1	X	X	X	110000h to 11FFFFh	088000h to 08FFFFh
	SA18	1	0	0	1	0	X	X	X	120000h to 12FFFFh	090000h to 097FFFh
	SA19	1	0	0	1	1	X	X	X	130000h to 13FFFFh	098000h to 09FFFFh
	SA20	1	0	1	0	0	X	X	X	140000h to 14FFFFh	0A0000h to 0A7FFFh
	SA21	1	0	1	0	1	X	X	X	150000h to 15FFFFh	0A8000h to 0AFFFFh
	SA22	1	0	1	1	0	X	X	X	160000h to 16FFFFh	0B0000h to 0B7FFFh
	SA23	1	0	1	1	1	X	X	X	170000h to 17FFFFh	0B8000h to 0BFFFFh
	SA24	1	1	0	0	0	X	X	X	180000h to 18FFFFh	0C0000h to 0C7FFFh
	SA25	1	1	0	0	1	X	X	X	190000h to 19FFFFh	0C8000h to 0CFFFFh
	SA26	1	1	0	1	0	X	X	X	1A0000h to 1AFFFFh	0D0000h to 0D7FFFh
	SA27	1	1	0	1	1	X	X	X	1B0000h to 1BFFFFh	0D8000h to 0DFFFFh
	SA28	1	1	1	0	0	X	X	X	1C0000h to 1CFFFFh	0E0000h to 0E7FFFh
	SA29	1	1	1	0	1	X	X	X	1D0000h to 1DFFFFh	0E8000h to 0EFFFFh
	SA30	1	1	1	1	0	X	X	X	1E0000h to 1EFFFFh	0F0000h to 0F7FFFh
	SA31	1	1	1	1	1	0	0	0	1F0000h to 1F1FFFh	0F8000h to 0F8FFFh
	SA32	1	1	1	1	1	0	0	1	1F2000h to 1F3FFFh	0F9000h to 0F9FFFh
	SA33	1	1	1	1	1	0	1	0	1F4000h to 1F5FFFh	0FA000h to 0FAFFFh
	SA34	1	1	1	1	1	0	1	1	1F6000h to 1F7FFFh	0FB000h to 0FBFFFh
	SA35	1	1	1	1	1	1	0	0	1F8000h to 1F9FFFh	0FC000h to 0FCFFFh
	SA36	1	1	1	1	1	1	0	1	1FA000h to 1FBFFFh	0FD000h to 0FDFFFh
	SA37	1	1	1	1	1	1	1	0	1FC000h to 1FDFFFh	0FE000h to 0FEFFFh
	SA38	1	1	1	1	1	1	1	1	1FE000h to 1FFFFFh	0FF000h to 0FFFFFh

MB84VD2118XA-85/MB84VD2119XA-85

Table 3.8 Sector Address Tables (MB84VD21194)

Bank	Sector	Sector Address								Address Range (BYTE mode)	Address Range (WORD mode)
		Bank Address									
		A ₁₉	A ₁₈	A ₁₇	A ₁₆	A ₁₅	A ₁₄	A ₁₃	A ₁₂		
Bank 1	SA0	0	0	0	0	0	0	0	0	000000h to 001FFFh	000000h to 000FFFh
	SA1	0	0	0	0	0	0	0	1	002000h to 003FFFh	001000h to 001FFFh
	SA2	0	0	0	0	0	0	0	1	004000h to 005FFFh	002000h to 002FFFh
	SA3	0	0	0	0	0	0	0	1	006000h to 007FFFh	003000h to 003FFFh
	SA4	0	0	0	0	0	1	0	0	008000h to 009FFFh	004000h to 004FFFh
	SA5	0	0	0	0	0	1	0	1	00A000h to 00BFFFh	005000h to 005FFFh
	SA6	0	0	0	0	0	1	1	0	00C000h to 00DFFFh	006000h to 006FFFh
	SA7	0	0	0	0	0	1	1	1	00E000h to 00FFFFh	007000h to 007FFFh
	SA8	0	0	0	0	1	X	X	X	010000h to 01FFFFh	008000h to 00FFFFh
	SA9	0	0	0	1	0	X	X	X	020000h to 02FFFFh	010000h to 017FFFh
	SA10	0	0	0	1	1	X	X	X	030000h to 03FFFFh	018000h to 01FFFFh
	SA11	0	0	1	0	0	X	X	X	040000h to 04FFFFh	020000h to 027FFFh
	SA12	0	0	1	0	1	X	X	X	050000h to 05FFFFh	028000h to 02FFFFh
	SA13	0	0	1	1	0	X	X	X	060000h to 06FFFFh	030000h to 037FFFh
	SA14	0	0	1	1	1	X	X	X	070000h to 07FFFFh	038000h to 03FFFFh
	SA15	0	1	0	0	0	X	X	X	080000h to 08FFFFh	040000h to 047FFFh
	SA16	0	1	0	0	1	X	X	X	090000h to 09FFFFh	048000h to 04FFFFh
	SA17	0	1	0	1	0	X	X	X	0A0000h to 0AFFFFh	050000h to 057FFFh
	SA18	0	1	0	1	1	X	X	X	0B0000h to 0BFFFFh	058000h to 05FFFFh
	SA19	0	1	1	0	0	X	X	X	0C0000h to 0CFFFFh	060000h to 067FFFh
	SA20	0	1	1	0	1	X	X	X	0D0000h to 0DFFFFh	068000h to 06FFFFh
	SA21	0	1	1	1	0	X	X	X	0E0000h to 0EFFFFh	070000h to 077FFFh
SA22	0	1	1	1	1	X	X	X	0F0000h to 0FFFFFh	078000h to 07FFFFh	
Bank 2	SA23	1	0	0	0	0	X	X	X	100000h to 10FFFFh	080000h to 087FFFh
	SA24	1	0	0	0	1	X	X	X	110000h to 11FFFFh	088000h to 08FFFFh
	SA25	1	0	0	1	0	X	X	X	120000h to 12FFFFh	090000h to 097FFFh
	SA26	1	0	0	1	1	X	X	X	130000h to 13FFFFh	098000h to 09FFFFh
	SA27	1	0	1	0	0	X	X	X	140000h to 14FFFFh	0A0000h to 0A7FFFh
	SA28	1	0	1	0	1	X	X	X	150000h to 15FFFFh	0A8000h to 0AFFFFh
	SA29	1	0	1	1	0	X	X	X	160000h to 16FFFFh	0B0000h to 0B7FFFh
	SA30	1	0	1	1	1	X	X	X	170000h to 17FFFFh	0B8000h to 0BFFFFh
	SA31	1	1	0	0	0	X	X	X	180000h to 18FFFFh	0C0000h to 0C7FFFh
	SA32	1	1	0	0	1	X	X	X	190000h to 19FFFFh	0C8000h to 0CFFFFh
	SA33	1	1	0	1	0	X	X	X	1A0000h to 1AFFFFh	0D0000h to 0D7FFFh
	SA34	1	1	0	1	1	X	X	X	1B0000h to 1BFFFFh	0D8000h to 0DFFFFh
	SA35	1	1	1	0	0	X	X	X	1C0000h to 1CFFFFh	0E0000h to 0E7FFFh
	SA36	1	1	1	0	1	X	X	X	1D0000h to 1DFFFFh	0E8000h to 0EFFFFh
	SA37	1	1	1	1	0	X	X	X	1E0000h to 1EFFFFh	0F0000h to 0F7FFFh
	SA38	1	1	1	1	1	X	X	X	1F0000h to 1FFFFFh	0F8000h to 0FFFFFh

MB84VD2118XA-85/MB84VD2119XA-85

**Table 4.1 Sector Group Address (MB84VD2118XA)
(Top Boot Block)**

Sector Group	A ₁₉	A ₁₈	A ₁₇	A ₁₆	A ₁₅	A ₁₄	A ₁₃	A ₁₂	Sectors
SGA0	0	0	0	0	0	X	X	X	SA0
SGA1	0	0	0	0	1	X	X	X	SA1 to SA3
	0	0	0	1	0	X	X	X	
	0	0	0	1	1	X	X	X	
SGA2	0	0	1	X	X	X	X	X	SA4 to SA7
SGA3	0	1	0	X	X	X	X	X	SA8 to SA11
SGA4	0	1	1	X	X	X	X	X	SA12 to SA15
SGA5	1	0	0	X	X	X	X	X	SA16 to SA19
SGA6	1	0	1	X	X	X	X	X	SA20 to SA23
SGA7	1	1	0	X	X	X	X	X	SA24 to SA27
SGA8	1	1	1	0	0	X	X	X	SA28 to SA30
	1	1	1	0	1	X	X	X	
	1	1	1	1	0	X	X	X	
SGA9	1	1	1	1	1	0	0	0	SA31
SGA10	1	1	1	1	1	0	0	1	SA32
SGA11	1	1	1	1	1	0	1	0	SA33
SGA12	1	1	1	1	1	0	1	1	SA34
SGA13	1	1	1	1	1	1	0	0	SA35
SGA14	1	1	1	1	1	1	0	1	SA36
SGA15	1	1	1	1	1	1	1	0	SA37
SGA16	1	1	1	1	1	1	1	1	SA38

MB84VD2118XA-85/MB84VD2119XA-85

**Table 4.2 Sector Group Address (MB84VD2119XA)
(Bottom Boot Block)**

Sector Group	A ₁₉	A ₁₈	A ₁₇	A ₁₆	A ₁₅	A ₁₄	A ₁₃	A ₁₂	Sectors
SGA0	0	0	0	0	0	0	0	0	SA0
SGA1	0	0	0	0	0	0	0	1	SA1
SGA2	0	0	0	0	0	0	1	0	SA2
SGA3	0	0	0	0	0	0	1	1	SA3
SGA4	0	0	0	0	0	1	0	0	SA4
SGA5	0	0	0	0	0	1	0	1	SA5
SGA6	0	0	0	0	0	1	1	0	SA6
SGA7	0	0	0	0	0	1	1	1	SA7
SGA8	0	0	0	0	1	X	X	X	SA8 to SA10
	0	0	0	1	0	X	X	X	
	0	0	0	1	1	X	X	X	
SGA9	0	0	1	X	X	X	X	X	SA11 to SA14
SGA10	0	1	0	X	X	X	X	X	SA15 to SA18
SGA11	0	1	1	X	X	X	X	X	SA19 to SA22
SGA12	1	0	0	X	X	X	X	X	SA23 to SA26
SGA13	1	0	1	X	X	X	X	X	SA27 to SA30
SGA14	1	1	0	X	X	X	X	X	SA31 to SA34
SGA15	1	1	1	0	0	X	X	X	SA35 to SA37
	1	1	1	0	1	X	X	X	
	1	1	1	1	0	X	X	X	
SGA16	1	1	1	1	1	X	X	X	SA38

MB84VD2118XA-85/MB84VD2119XA-85

Table 5 Flash Memory Autoselect Codes

Type		A ₁₂ to A ₁₉	A ₆	A ₁	A ₀	A ₋₁ *1	Code (hEX)	
Manufacturer's Code		X	V _{IL}	V _{IL}	V _{IL}	V _{IL}	04h	
Device Code	MB84VD21181A	Byte	X	V _{IL}	V _{IL}	V _{IH}	V _{IL}	36h
		Word					X	2236h
	MB84VD21191A	Byte	X	V _{IL}	V _{IL}	V _{IH}	V _{IL}	39h
		Word					X	2239h
	MB84VD21182A	Byte	X	V _{IL}	V _{IL}	V _{IH}	V _{IL}	2Dh
		Word					X	222Dh
	MB84VD21192A	Byte	X	V _{IL}	V _{IL}	V _{IH}	V _{IL}	2Eh
		Word					X	222Eh
	MB84VD21183A	Byte	X	V _{IL}	V _{IL}	V _{IH}	V _{IL}	28h
		Word					X	2228h
	MB84VD21193A	Byte	X	V _{IL}	V _{IL}	V _{IH}	V _{IL}	2Bh
		Word					X	222Bh
	MB84VD21184A	Byte	X	V _{IL}	V _{IL}	V _{IH}	V _{IL}	33h
		Word					X	2233h
	MB84VD21194A	Byte	X	V _{IL}	V _{IL}	V _{IH}	V _{IL}	35h
		Word					X	2235h
Sector Group protect		Sector Group Address	V _{IL}	V _{IH}	V _{IL}	V _{IL}	01h*2	

*1 : A₋₁ is for Byte mode.

*2 : Output 01h at protected sector address and output 00h at unprotected sector address.

MB84VD2118XA-85/MB84VD2119XA-85

Table 6 Flash Memory Command Definitions

Command Sequence		Bus Write Cycles Req'd	First Bus Write Cycle		Second Bus Write Cycle		Third Bus Write Cycle		Fourth Bus Read/Write Cycle		Fifth Bus Write Cycle		Sixth Bus Write Cycle	
			Addr.	Data	Addr.	Data	Addr.	Data	Addr.	Data	Addr.	Data	Addr.	Data
Read/Reset *1		1	XXXh	F0h	—	—	—	—	—	—	—	—	—	—
Read/Reset *1	Word	3	555h	AAh	2AAh	55h	555h	F0h	RA	RD	—	—	—	—
	Byte		AAAh		555h		AAAh							
Autoselect	Word	3	555h	AAh	2AAh	55h	(BA) 555h	90h	—	—	—	—	—	—
	Byte		AAAh		555h		(BA) AAAh							
Program	Word	4	555h	AAh	2AAh	55h	555h	A0h	PA	PD	—	—	—	—
	Byte		AAAh		555h		AAAh							
Chip Erase	Word	6	555h	AAh	2AAh	55h	555h	80h	555h	AAh	2AAh	55h	555h	10h
	Byte		AAAh		555h		AAAh		AAAh		AAAh			
Sector Erase	Word	6	555h	AAh	2AAh	55h	555h	80h	555h	AAh	2AAh	55h	SA	30h
	Byte		AAAh		555h		AAAh		AAAh		AAAh			
Sector Erase Suspend		1	BA	B0h	—	—	—	—	—	—	—	—	—	—
Sector Erase Resume		1	BA	30h	—	—	—	—	—	—	—	—	—	—
Set to Fast Mode	Word	3	555h	AAh	2AAh	55h	555h	20h	—	—	—	—	—	—
	Byte		AAAh		555h		AAAh							
Fast Program *2	Word	2	XXXh	A0h	PA	PD	—	—	—	—	—	—	—	—
	Byte		—	—	—	—	—	—	—	—	—	—	—	—
Reset from Fast Mode *2	Word	2	BA	90h	XXXh	F0h *6	—	—	—	—	—	—	—	—
	Byte		—	—	—	—	—	—	—	—	—	—	—	—
Extended Sector Group Protection *3	Word	4	XXXh	60h	SPA	60h	SPA	40h	SPA	SD	—	—	—	—
	Byte		—	—	—	—	—	—	—	—	—	—	—	—
Query *4	Word	1	55h	98h	—	—	—	—	—	—	—	—	—	—
	Byte		AAh	—	—	—	—	—	—	—	—	—	—	—
Hi-ROM Entry	Word	3	555h	AAh	2AAh	55h	555h	88h	—	—	—	—	—	—
	Byte		AAAh		555h		AAAh							
Hi-ROM Program *5	Word	4	555h	AAh	2AAh	55h	555h	A0h	PA	PD	—	—	—	—
	Byte		AAAh		555h		AAAh							
Hi-ROM Erase *5	Word	6	555h	AAh	2AAh	55h	555h	80h	555h	AAh	2AAh	55h	HRA	30h
	Byte		AAAh		555h		AAAh		AAAh					
Hi-ROM Exit *5	Word	4	555h	AAh	2AAh	55h	(HRBA) 555h	90h	XXXh	00h	—	—	—	—
	Byte		AAAh		555h		(HRBA) AAAh							

MB84VD2118XA-85/MB84VD2119XA-85

- *1: Both Read/Reset commands are functionally equivalent, resetting the device to the read mode.
- *2: This command is valid while Fast Mode.
- *3: This command is valid while $\overline{\text{RESET}} = V_{\text{ID}}$.
- *4: The valid Address is A_0 to A_6 .
- *5: This command is valid while Hi-ROM mode.
- *6: The data "00h" is also acceptable.

Address bits A_{12} to $A_{19} = X = \text{"H" or "L"}$ for all address commands except for Program Address (PA) , Sector Address (SA) , and Bank Address (BA) .

Bus operations are defined in Table 2 "User Bus Operations".

RA = Address of the memory location to be read.

PA = Address of the memory location to be programmed.

Addresses are latched on the falling edge of the write pulse.

SA = Address of the sector to be erased. The combination of A_{19} , A_{18} , A_{17} , A_{16} , A_{15} , A_{14} , A_{13} , and A_{12} will uniquely select any sector.

BA = Bank address (A_{15} to A_{19})

SPA = Sector group address to be protected. Set sector group address (SGA) and (A_6 , A_1 , A_0) = (0, 1, 0).

HRA = Address of the Hidden-ROM area.

SPA = Sector group address to be protected. Set sector group address (SGA) and (A_6 , A_1 , A_0) = (0, 1, 0).

HRA = Address of the Hidden-ROM area.

MB84VD2118XA (Top Boot Type) Word mode: 0F8000h to 0FFFFFFh

Byte mode: 1F0000h to 1FFFFFFh

MB84VD2119XA (Bottom Boot Type) Word mode: 000000h to 007FFFh

Byte mode: 000000h to 00FFFFh

HRBA = Bank address of the Hidden-ROM area.

MB84VD2118XA (Top Boot Type) : $A_{15} = A_{16} = A_{17} = A_{18} = A_{19} = A_{20} = 1$

MB84VD2119XA (Bottom Boot Type) : $A_{15} = A_{16} = A_{17} = A_{18} = A_{19} = A_{20} = 0$

RD = Data read from location RA during read operation.

PD = Data to be programmed at location PA.

SD = Sector protection verify data. Output 01h at protected sector addresses and output 00h at unprotected sector addresses.

The system should generate the following address patterns;

Word mode : 555h or 2AAh to addresses A_0 to A_{10}

Byte mode : AAh or 55h to addresses A_{-1} and A_0 to A_{10}

MB84VD2118XA-85/MB84VD2119XA-85

■ ABSOLUTE MAXIMUM RATINGS

Parameter	Symbol	Rating		Unit
		Min.	Max.	
Storage Temperature	T _{stg}	-55	+125	°C
Ambient Temperature with Power Applied	T _A	-25	+85	°C
Voltage with Respect to Ground All pins except RESET and WP/ACC *1	V _{IN} , V _{OUT}	-0.3	V _{ccf} + 0.4 V _{ccs} + 0.4	V
V _{ccf} /V _{ccs} Supply *1	V _{ccf} , V _{ccs}	-0.3	+4.0	V
RESET *2	V _{IN}	-0.5	+13.0	V
WP/ACC *3	V _{IN}	-0.5	+10.5	V

*1: Minimum DC voltage on input or I/O pins is -0.3 V. During voltage transitions, input or I/O pins may undershoot V_{SS} to -2.0 V for periods of up to 20 ns. Maximum DC voltage on input or I/O pins is V_{ccf} + 0.4 V or V_{ccs} + 0.4 V. During voltage transitions, input or I/O pins may overshoot to V_{ccf} + 2.0 V or V_{ccs} + 2.0 V for periods of up to 20 ns.

*2: Minimum DC input voltage on RESET pin is -0.5 V. During voltage transitions, RESET pin may undershoot V_{SS} to -2.0 V for periods of up to 20 ns.

Voltage difference between input and supply voltage (V_{IN} - V_{ccf} or V_{ccs}) does not exceed 9.0 V.

Maximum DC input voltage on RESET pin is +13.0 V which may overshoot to +14.0 V for periods of up to 20 ns.

*3: Minimum DC input voltage on WP/ACC pin is -0.5 V. During voltage transitions, WP/ACC pin may undershoot V_{SS} to -2.0 V for periods of up to 20 ns. Maximum DC input voltage on WP/ACC pin is +10.5 V which may overshoot to +12.0 V for periods of up to 20 ns, when V_{ccf} is applied.

WARNING: Semiconductor devices can be permanently damaged by application of stress (voltage, current, temperature, etc.) in excess of absolute maximum ratings. Do not exceed these ratings.

■ RECOMMENDED OPERATING CONDITIONS

Parameter	Symbol	Value		Unit
		Min.	Max.	
Ambient Temperature	T _A	-25	+85	°C
V _{ccf} /V _{ccs} Supply Voltages	V _{ccf} , V _{ccs}	+2.7	+3.6	V

Note: Operating ranges define those limits between which the functionality of the device is guaranteed.

WARNING: The recommended operating conditions are required in order to ensure the normal operation of the semiconductor device. All of the device's electrical characteristics are warranted when the device is operated within these ranges.

Always use semiconductor devices within their recommended operating condition ranges. Operation outside these ranges may adversely affect reliability and could result in device failure.

No warranty is made with respect to uses, operating conditions, or combinations not represented on the data sheet. Users considering application outside the listed conditions are advised to contact their FUJITSU representatives beforehand.

MB84VD2118XA-85/MB84VD2119XA-85

■ ELECTRICAL CHARACTERISTICS

1. DC Characteristics

Parameter	Symbol	Test Conditions	Value			Unit		
			Min.	Typ.	Max.			
Input Leakage Current	I _{LI}	V _{IN} = V _{SS} to V _{CCf} , V _{CCS}	-1.0	—	+1.0	μA		
Output Leakage Current	I _{LO}	V _{OUT} = V _{SS} to V _{CCf} , V _{CCS}	-1.0	—	+1.0	μA		
$\overline{\text{RESET}}$ Inputs Leakage Current	I _{LIT}	V _{CCf} = V _{CCf} Max, $\overline{\text{RESET}}$ = 12.5V	—	—	35	μA		
ACC Input Leakage Current	I _{LIA}	V _{CCf} = V _{CCf} Max, $\overline{\text{WP/ACC}}$ = V _{ACC} Max	—	—	20	mA		
Flash V _{CC} Active Current (Read) *1	I _{CC1f}	$\overline{\text{CEf}} = V_{IL}$, $\overline{\text{OE}} = V_{IH}$	t _{CYCLE} = 5 MHz	Byte	—	—	13	mA
			t _{CYCLE} = 5 MHz	Word	—	—	15	
			t _{CYCLE} = 1 MHz	Byte	—	—	7	mA
			t _{CYCLE} = 1 MHz	Word	—	—	7	
Flash V _{CC} Active Current (Program/Erase) *2	I _{CC2f}	$\overline{\text{CEf}} = V_{IL}$, $\overline{\text{OE}} = V_{IH}$	—	—	35	mA		
Flash V _{CC} Active Current (Read-While-Program) *5	I _{CC3f}	$\overline{\text{CEf}} = V_{IL}$, $\overline{\text{OE}} = V_{IH}$	Byte	—	—	48	mA	
			Word	—	—	50		
Flash V _{CC} Active Current (Read-While-Erase) *5	I _{CC4f}	$\overline{\text{CEf}} = V_{IL}$, $\overline{\text{OE}} = V_{IH}$	Byte	—	—	48	mA	
			Word	—	—	50		
Flash V _{CC} Active Current (Erase-Suspend-Program)	I _{CC5f}	$\overline{\text{CEf}} = V_{IL}$, $\overline{\text{OE}} = V_{IH}$	—	—	35	mA		
SRAM V _{CC} Active Current	I _{CC1S}	V _{CCS} = V _{CCS} Max., $\overline{\text{CE1s}} = V_{IL}$, $\overline{\text{CE2s}} = V_{IH}$	t _{CYCLE} = 10 MHz	—	—	40	mA	
SRAM V _{CC} Active Current	I _{CC2S}	$\overline{\text{CE1s}} = 0.2\text{ V}$, $\overline{\text{CE2s}} = V_{CCS} - 0.2\text{ V}$,	t _{CYCLE} = 10 MHz	—	—	40	mA	
			t _{CYCLE} = 1 MHz	—	—	8	mA	
Flash V _{CC} Standby Current	I _{SB1f}	V _{CCf} = V _{CCf} Max., $\overline{\text{CEf}} = V_{CCf} \pm 0.3\text{ V}$ $\overline{\text{RESET}} = V_{CCf} \pm 0.3\text{ V}$, $\overline{\text{WP/ACC}} = V_{CCf} \pm 0.3\text{ V}$	—	1	5	μA		
Flash V _{CC} Standby Current ($\overline{\text{RESET}}$)	I _{SB2f}	V _{CCf} = V _{CCf} Max., $\overline{\text{RESET}} = V_{SS} \pm 0.3\text{ V}$ $\overline{\text{WP/ACC}} = V_{CCf} \pm 0.3\text{ V}$	—	1	5	μA		
Flash V _{CC} Current (Automatic Sleep Mode)*3	I _{SB3f}	V _{CCf} = V _{CCf} Max., $\overline{\text{CEf}} = V_{SS} \pm 0.3\text{ V}$ $\overline{\text{RESET}} = V_{CCf} \pm 0.3\text{ V}$, $\overline{\text{WP/ACC}} = V_{CCf} \pm 0.3\text{ V}$ V _{IN} = V _{CCf} ± 0.3 V or V _{SS} ± 0.3 V	—	1	5	μA		
SRAM V _{CC} Standby Current	I _{SB1S}	$\overline{\text{CE1s}} \geq V_{CCS} - 0.2\text{ V}$, $\overline{\text{CE2s}} \geq V_{CCS} - 0.2\text{ V}$	—	0.2	7	μA		
SRAM V _{CC} Standby Current	I _{SB2S}	$\overline{\text{CE2s}} \leq 0.2\text{ V}$	—	0.2	7	μA		

(Continued)

MB84VD2118XA-85/MB84VD2119XA-85

(Continued)

Parameter	Symbol	Test Conditions	Value			Unit
			Min.	Typ.	Max.	
Input Low Level	V_{IL}	—	-0.3	—	0.5	V
Input High Level	V_{IH}	—	2.4	—	$V_{CC} + 0.3$ *6	V
Voltage for Sector Protection, and Temporary Sector Unprotection (RESET) *4	V_{ID}	—	11.5	—	12.5	V
Voltage for Program Acceleration (\overline{WP}/ACC) *4	V_{ACC}	—	8.5	9.0	9.5	V
Output Low Voltage Level	V_{OL}	$V_{CCF} = V_{CCF} \text{ Min.}, V_{CCS} = V_{CCS} \text{ Min.}, I_{OL} = 1.0 \text{ mA}$	—	—	0.4	V
Output High Voltage Level	V_{OH}	$V_{CCF} = V_{CCF} \text{ Min.}, V_{CCS} = V_{CCS} \text{ Min.}, I_{OH} = -0.5 \text{ mA}$	2.4	—	—	V
Flash Low V_{CCF} Lock-Out Voltage	V_{LKO}	—	2.3	—	2.5	V

*1: The I_{CC} current listed includes both the DC operating current and the frequency dependent component.

*2: I_{CC} active while Embedded Algorithm (program or erase) is in progress.

*3: Automatic sleep mode enables the low power mode when address remain stable for 150ns.

*4: Applicable for only V_{CCF} applying.

*5: Embedded Alogrithm (program or erase) is in progress. (@5MHz)

*6: V_{CC} indicates lower of V_{CCF} or V_{CCS} .

2. AC Characteristics

• \overline{CE} Timing

Parameter	Symbol		Test Setup	Value	Unit
	JEDEC	Standard		Min.	
\overline{CE} Recover Time	—	t _{CCR}	—	0	ns

• Timing Diagram for alternating SRAM to Flash

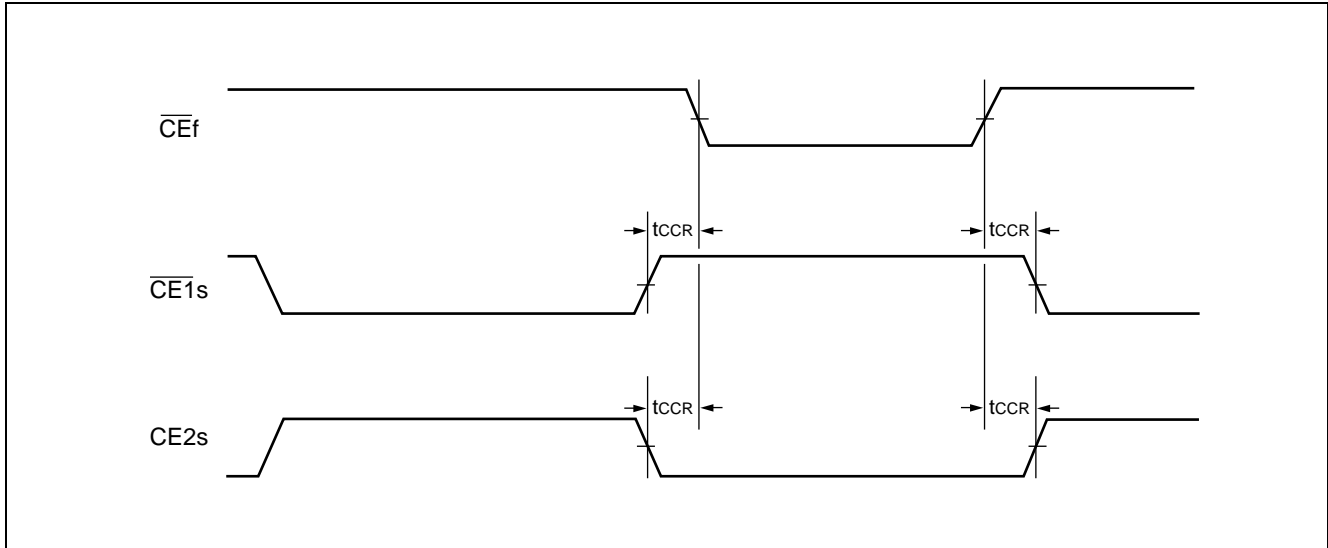

MB84VD2118XA-85/MB84VD2119XA-85

• Read Only Operations Characteristics (Flash)

Parameter	Symbol		Test Setup	Value (Note)		Unit
	JEDEC	Standard		Min.	Max.	
Read Cycle Time	t _{AVAV}	t _{RC}	—	85	—	ns
Address to Output Delay	t _{AVQV}	t _{ACC}	$\overline{CE}f = V_{IL}$ $\overline{OE} = V_{IL}$	—	85	ns
Chip Enable to Output Delay	t _{ELQV}	t _{CEf}	$\overline{OE} = V_{IL}$	—	85	ns
Output Enable to Output Delay	t _{GLQV}	t _{OE}	—	—	35	ns
Chip Enable to Output High-Z	t _{EHQZ}	t _{DF}	—	—	30	ns
Output Enable to Output High-Z	t _{GHQZ}	t _{DF}	—	—	30	ns
Output Hold Time From Addresses, $\overline{CE}f$ or \overline{OE} , Whichever Occurs First	t _{AXQX}	t _{OH}	—	0	—	ns
\overline{RESET} Pin Low to Read Mode	—	t _{READY}	—	—	20	μs

Note : Test Conditions – Output Load : 1 TTL gate and 30 pF
 Input rise and fall times : 5 ns
 Input pulse levels : 0.0 V to 3.0 V
 Timing measurement reference level
 Input : 1.5 V
 Output : 1.5 V

MB84VD2118XA-85/MB84VD2119XA-85

• Read Cycle (Flash)

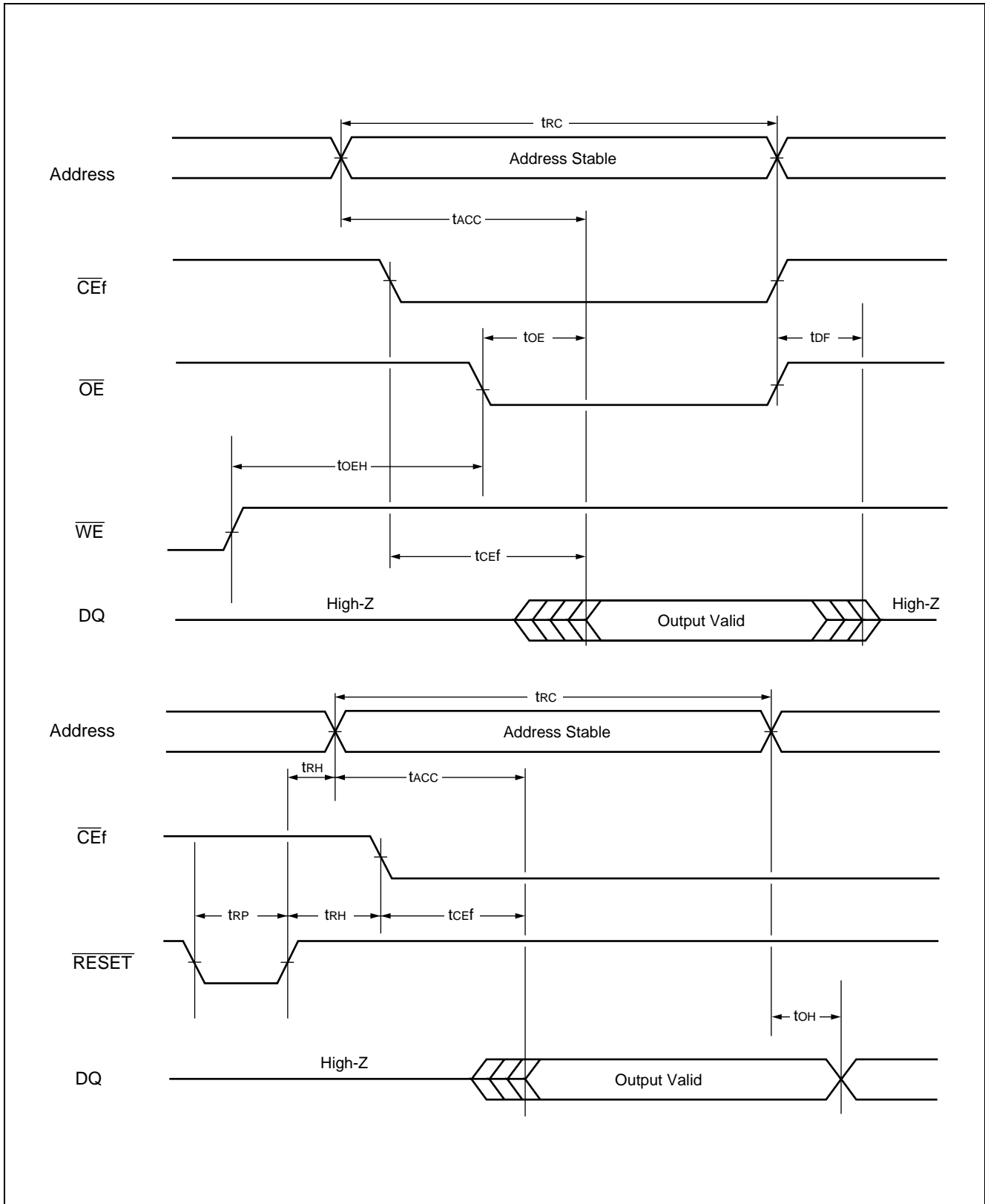

MB84VD2118XA-85/MB84VD2119XA-85

• Erase/Program Operations (Flash)

Parameter	Symbol		Value			Unit
	JEDEC	Standard	Min.	Typ.	Max.	
Write Cycle Time	t _{AVAV}	t _{WC}	85	—	—	ns
Address Setup Time (\overline{WE} to Addr.)	t _{AVWL}	t _{AS}	0	—	—	ns
Address Setup Time to \overline{CEf} Low During Toggle Bit Polling	—	t _{ASO}	15	—	—	ns
Address Hold Time (\overline{WE} to Addr.)	t _{WLAX}	t _{AH}	45	—	—	ns
Address Hold Time from \overline{CEf} or \overline{OE} High During Toggle Bit Polling	—	t _{AHT}	0	—	—	ns
Data Setup Time	t _{DVWH}	t _{DS}	35	—	—	ns
Data Hold Time	t _{WHDX}	t _{DH}	0	—	—	ns
Output Enable Setup Time	—	t _{OES}	0	—	—	ns
Output Enable Hold Time	Read	t _{OEH}	0	—	—	ns
	Toggle and \overline{Data} Polling		10	—	—	ns
\overline{CEf} High During Toggle Bit Polling	—	t _{CEPH}	20	—	—	ns
\overline{OE} High During Toggle Bit Polling	—	t _{OEPH}	20	—	—	ns
Read Recover Time Before Write (\overline{OE} to \overline{CEf})	t _{GH\overline{E}L}	t _{GH\overline{E}L}	0	—	—	ns
Read Recover Time Before Write (\overline{OE} to \overline{WE})	t _{GHWL}	t _{GHWL}	0	—	—	ns
\overline{WE} Setup Time (\overline{CEf} to \overline{WE})	t _{WLEL}	t _{WS}	0	—	—	ns
\overline{CEf} Setup Time (\overline{WE} to \overline{CEf})	t _{ELWL}	t _{CS}	0	—	—	ns
\overline{WE} Hold Time (\overline{CEf} to \overline{WE})	t _{EHWH}	t _{WH}	0	—	—	ns
\overline{CEf} Hold Time (\overline{WE} to \overline{CEf})	t _{WHEH}	t _{CH}	0	—	—	ns
Write Pulse Width	t _{WLWH}	t _{WP}	35	—	—	ns
\overline{CEf} Pulse Width	t _{ELEH}	t _{CP}	35	—	—	ns
Write Pulse Width High	t _{WHWL}	t _{WPH}	30	—	—	ns
\overline{CEf} Pulse Width High	t _{EHEL}	t _{CPH}	30	—	—	ns
Byte Programming Operation	t _{WHWH1}	t _{WHWH1}	—	8	—	μ s
Word Programming Operation			—	16	—	μ s
Sector Erase Operation *1	t _{WHWH2}	t _{WHWH2}	—	1	—	s

(Continued)

MB84VD2118XA-85/MB84VD2119XA-85

(Continued)

Parameter	Symbol		Value			Unit
	JEDEC	Standard	Min.	Typ.	Max.	
V _{ccf} Setup Time	—	t _{VCS}	50	—	—	μs
Voltage Transition Time *2	—	t _{VLHT}	4	—	—	μs
Rise Time to V _{ID} *2	—	t _{VIDR}	500	—	—	ns
Rise Time to V _{ACC}	—	t _{VACCR}	500	—	—	ns
Recover Time from RY/ $\overline{\text{BY}}$	—	t _{RB}	0	—	—	ns
$\overline{\text{RESET}}$ Pulse Width	—	t _{RP}	500	—	—	ns
Delay Time from Embedded Output Enable	—	t _{EOE}	—	—	85	ns
$\overline{\text{RESET}}$ Hold Time Before Read	—	t _{RH}	200	—	—	ns
Program/Erase Valid to RY/ $\overline{\text{BY}}$ Delay	—	t _{BUSY}	—	—	90	ns
Erase Time-out Time *3	—	t _{TOW}	50	—	—	μs
Erase Suspend Transition Time *4	—	t _{SPD}	—	—	20	μs

*1: This does not include the preprogramming time.

*2: This timing is for Sector Protection Operation.

*3: The time between writes must be less than “t_{TOW}” otherwise that command will not be accepted and erasure will start. A time-out or “t_{TOW}” from the rising edge of last $\overline{\text{CEf}}$ or $\overline{\text{WE}}$ whichever happens first will initiate the execution of the Sector Erase command (s) .

*4: When the Erase Suspend command is written during the Sector Erase operation, the device will take a maximum of “t_{SPD}” to suspend the erase operation.

• Write Cycle (WE control) (Flash)

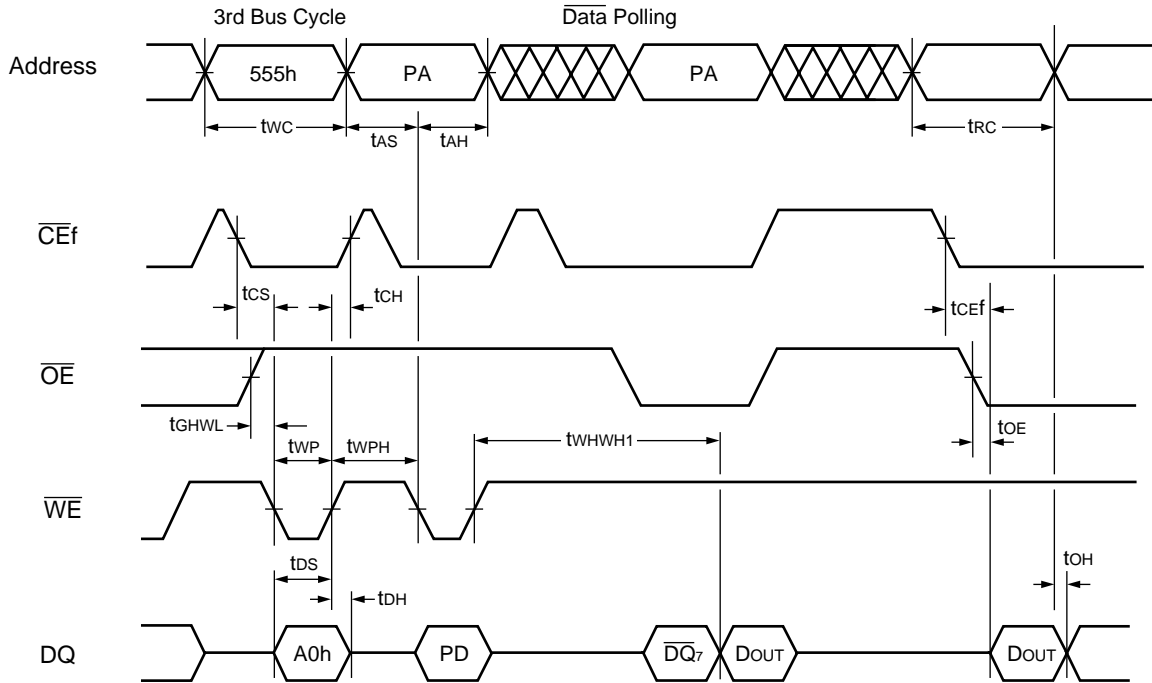

- Notes :
1. PA is address of the memory location to be programmed.
 2. PD is data to be programmed at byte address.
 3. \overline{DQ}_7 is the output of the complement of the data written to the device.
 4. D_{OUT} is the output of the data written to the device.
 5. Figure indicates last two bus cycles out of four bus cycle sequence.
 6. These waveforms are for the $\times 16$ mode. (The addresses differ from $\times 8$ mode.)

MB84VD2118XA-85/MB84VD2119XA-85

• Write Cycle ($\overline{\text{CEf}}$ control) (Flash)

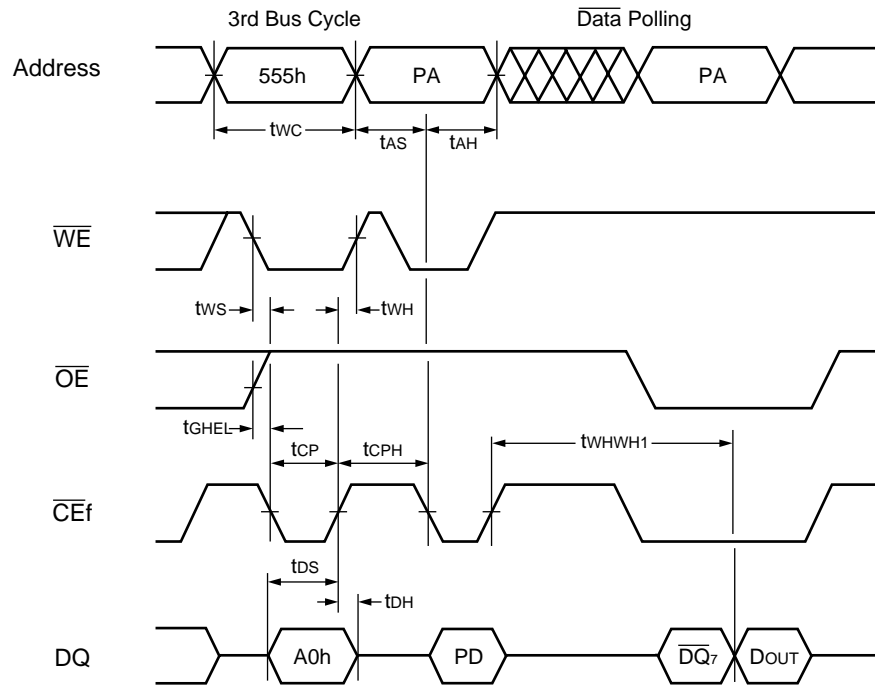

- Notes :
1. PA is address of the memory location to be programmed.
 2. PD is data to be programmed at byte address.
 3. $\overline{\text{DQ}}_7$ is the output of the complement of the data written to the device.
 4. D_{OUT} is the output of the data written to the device.
 5. Figure indicates last two bus cycles out of four bus cycle sequence.
 6. These waveforms are for the $\times 16$ mode. (The addresses differ from $\times 8$ mode.)

MB84VD2118XA-85/MB84VD2119XA-85

• AC Waveforms Chip/Sector Erase Operations (Flash)

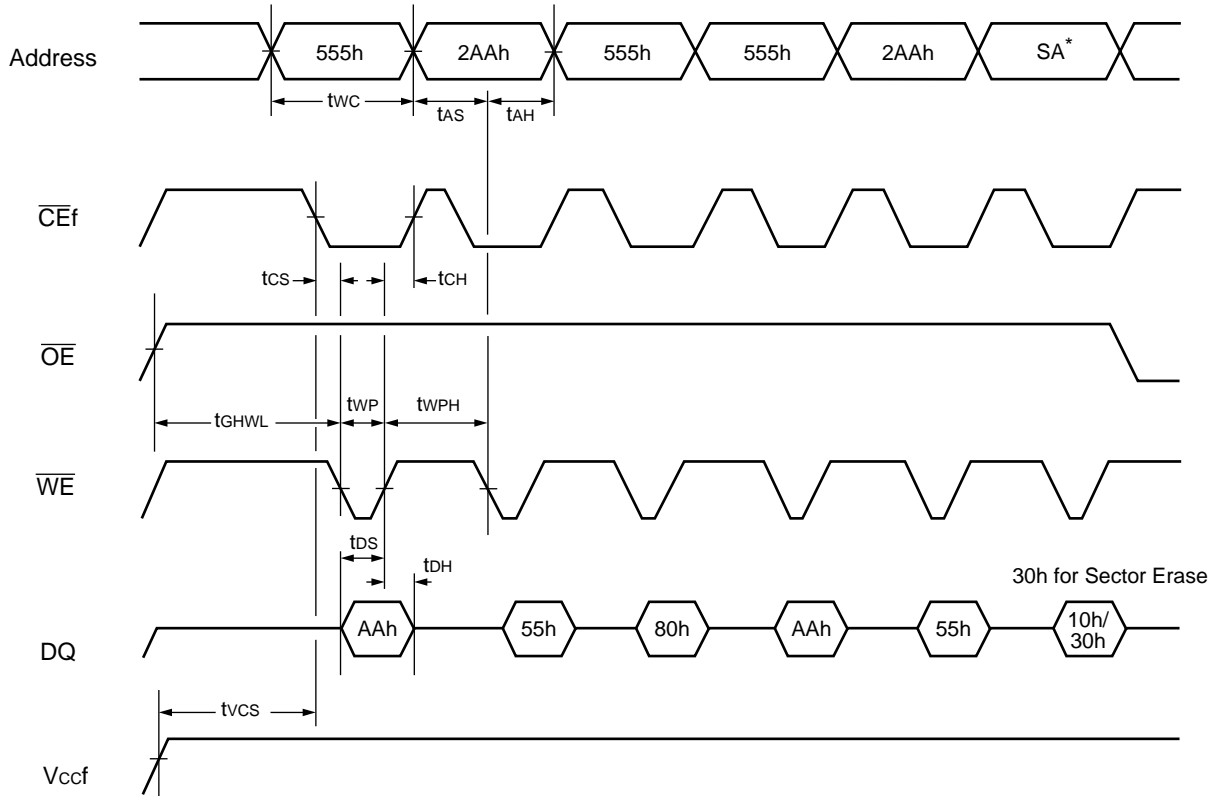

*: SA is the sector address for Sector Erase. Address = 555h for Chip Erase.

Note : These waveforms are for the $\times 16$ mode. (The addresses differ from $\times 8$ mode.)

MB84VD2118XA-85/MB84VD2119XA-85

• AC Waveforms for $\overline{\text{Data Polling}}$ during Embedded Algorithm Operations (Flash)

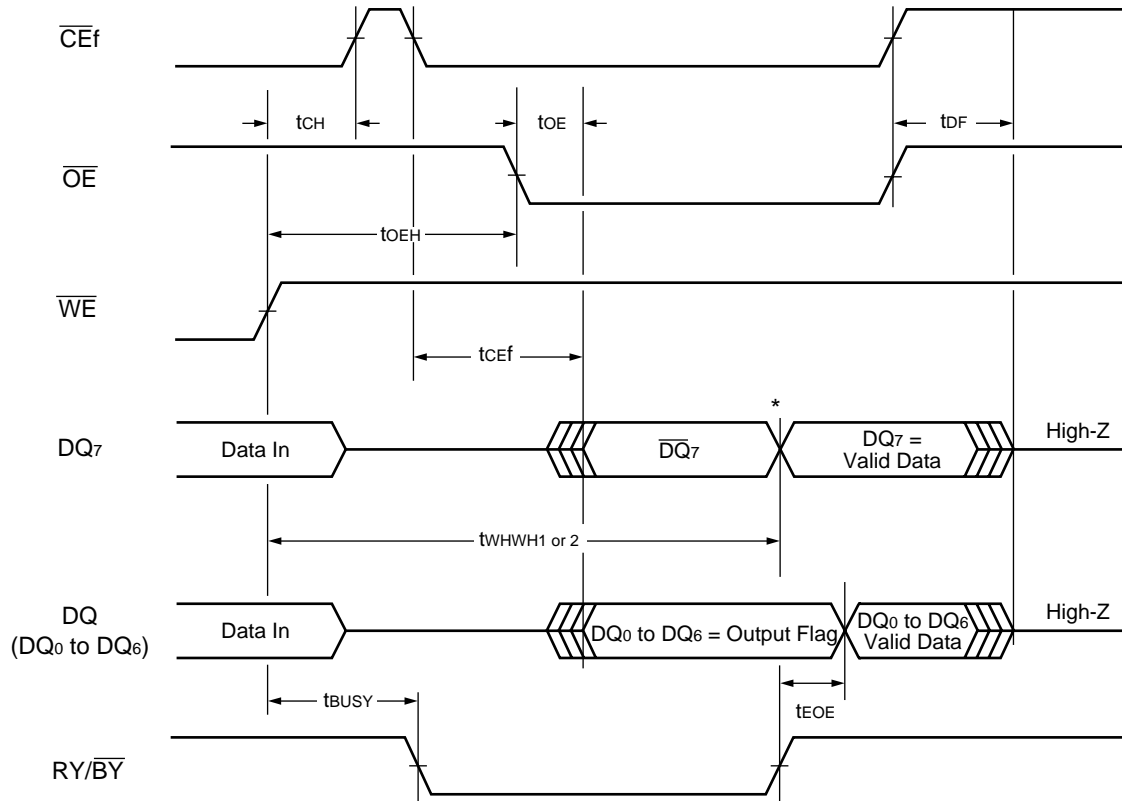

*: $\text{DQ}_7 = \text{Valid Data}$ (The device has completed the Embedded operation.)

MB84VD2118XA-85/MB84VD2119XA-85

• AC Waveforms for Toggle Bit during Embedded Algorithm Operations (Flash)

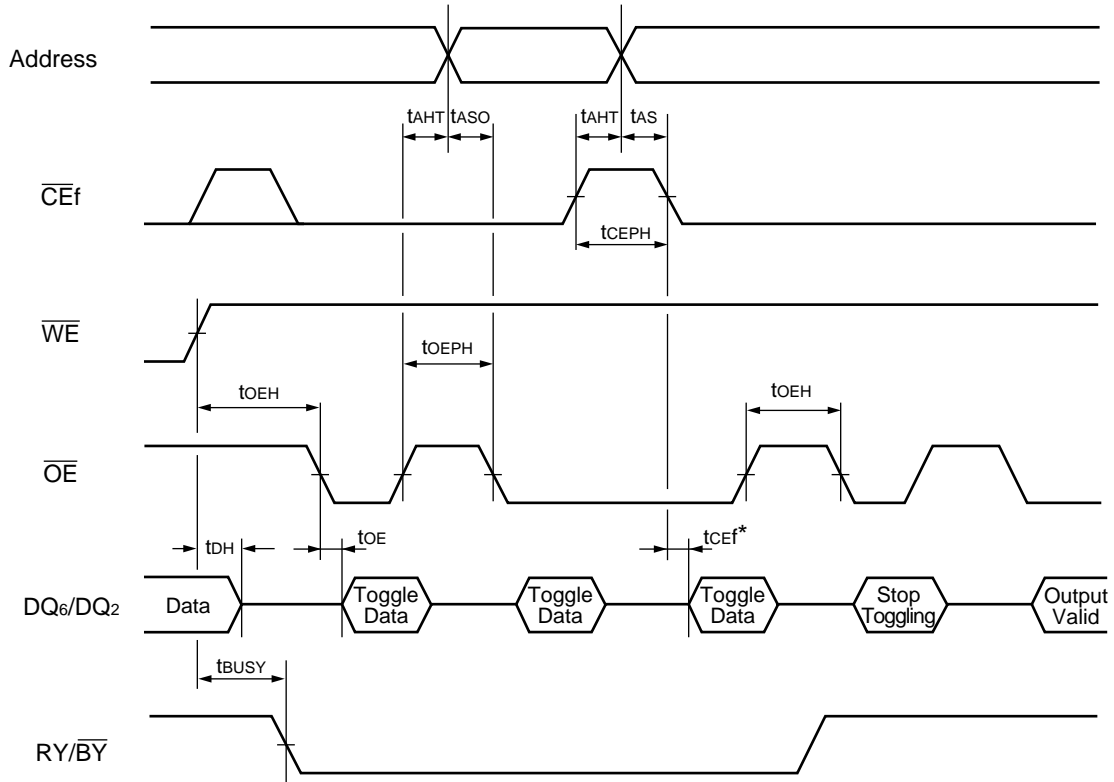

* : DQ_6 stops toggling (The device has completed the Embedded operation) .

MB84VD2118XA-85/MB84VD2119XA-85

• Back-to-back Read/Write Timing Diagram (Flash)

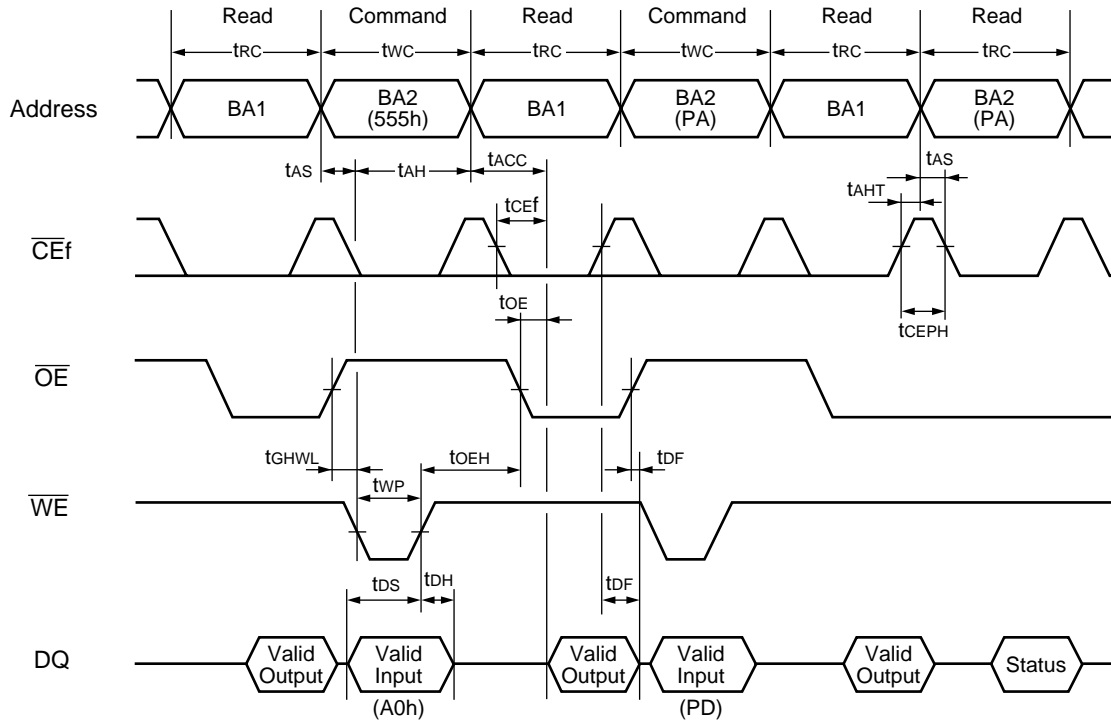

Note : This is example of Read for Bank 1 and Embedded Algorithm (program) for Bank 2.

BA1 : Address of Bank 1.

BA2 : Address of Bank 2.

- $\overline{RY}/\overline{BY}$ Timing Diagram during Write/Erase Operations (Flash)

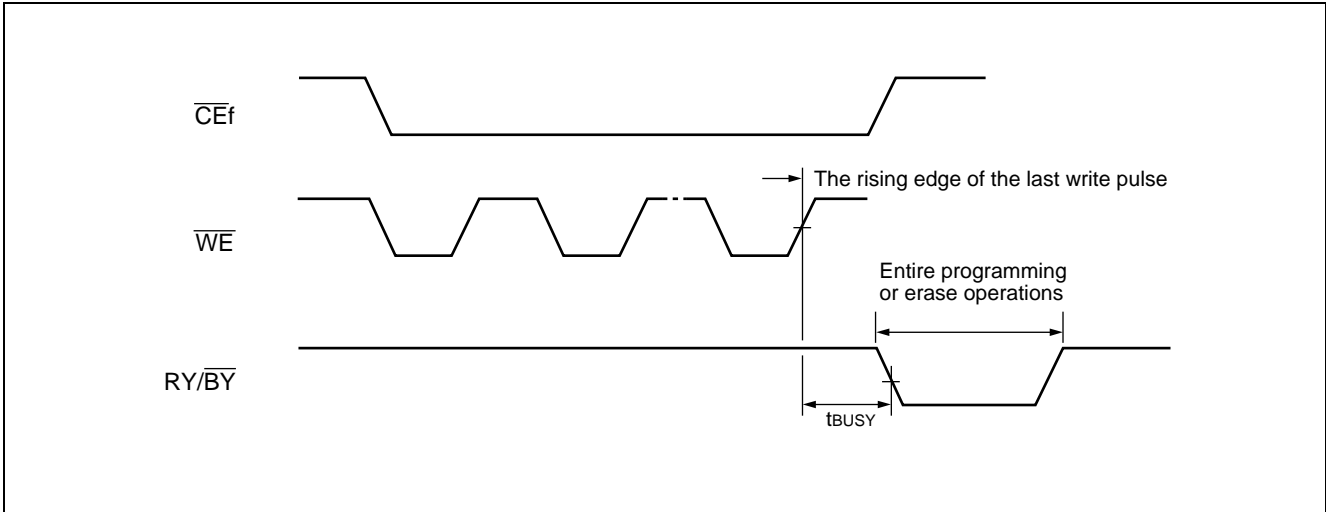

- \overline{RESET} , $\overline{RY}/\overline{BY}$ Timing Diagram (Flash)

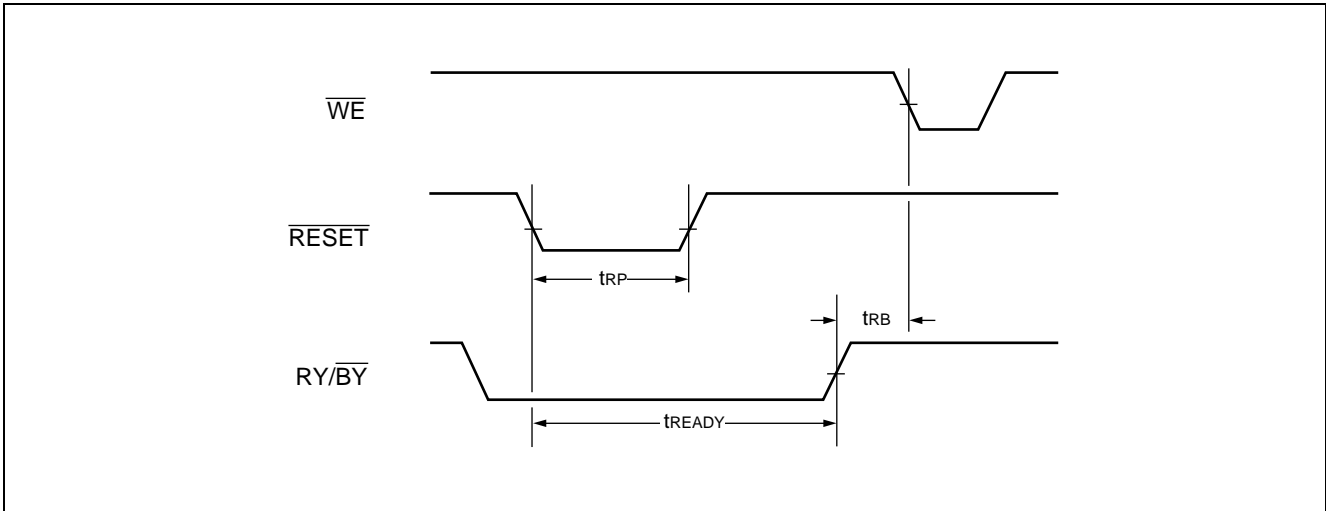

MB84VD2118XA-85/MB84VD2119XA-85

• Temporary Sector Unprotection (Flash)

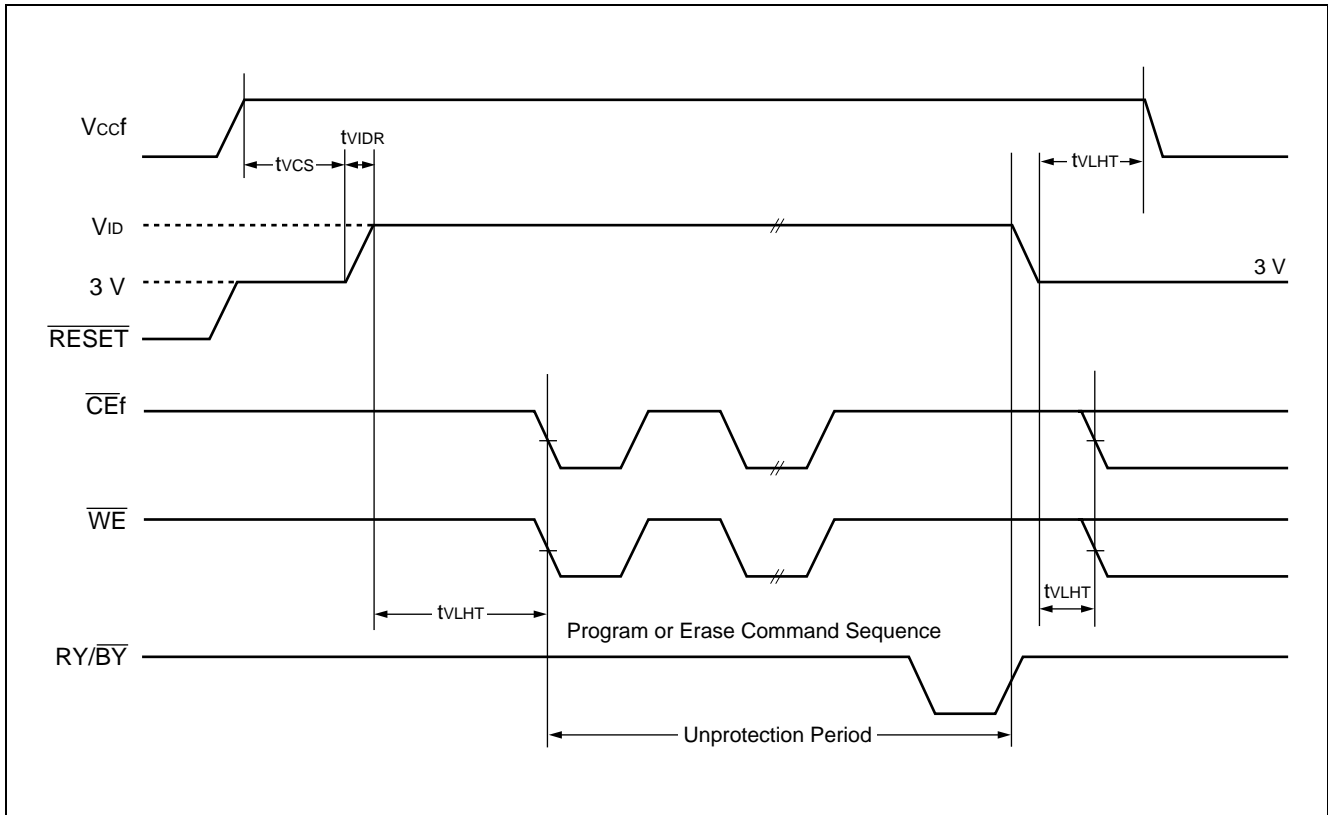

• Extended Sector Protection (Flash)

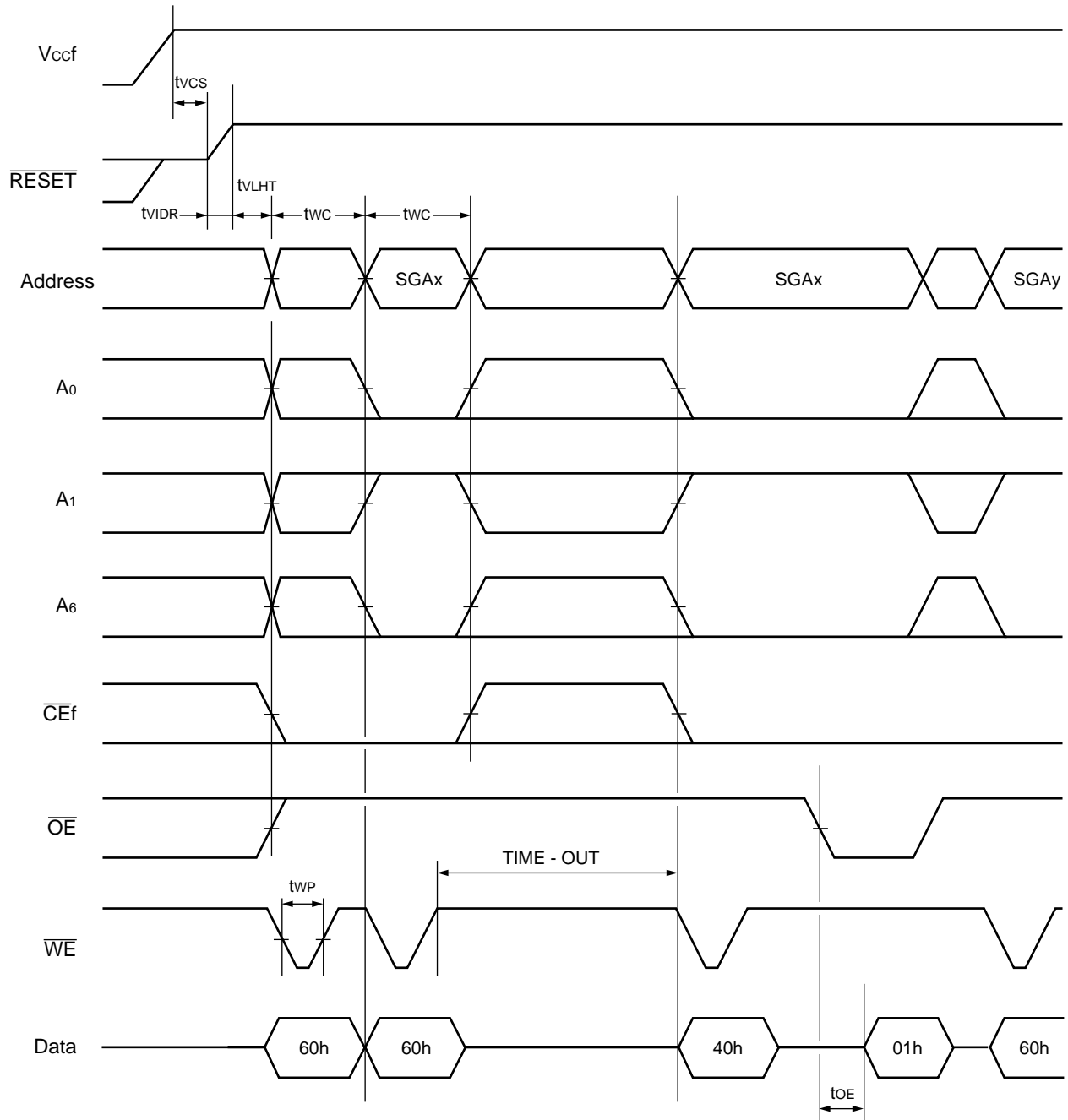

SGAx : Sector Group Address to be protected
 SGAy : Next Group Sector Address to be protected
 TIME-OUT : Time-Out window = 250 μ s (Min.)

MB84VD2118XA-85/MB84VD2119XA-85

• Accelerated Program (Flash)

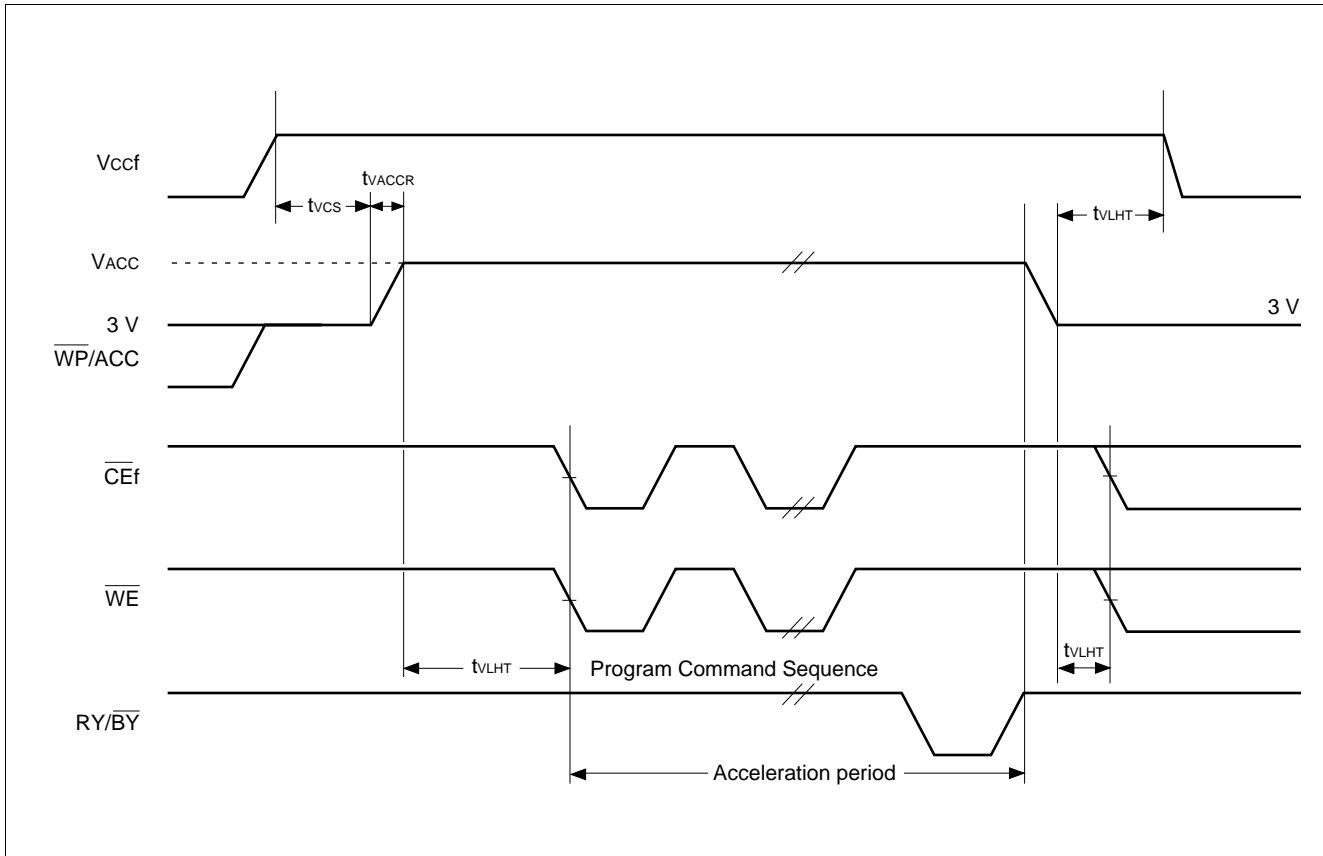

MB84VD2118XA-85/MB84VD2119XA-85

• Read Cycle (SRAM)

Parameter	Symbol	Value		Unit
		Min.	Max.	
Read Cycle Time	t_{RC}	85	—	ns
Address Access Time	t_{AA}	—	85	ns
Chip Enable ($\overline{CE1}$ s) Access Time	t_{CO1}	—	85	ns
Chip Enable (CE2s) Access Time	t_{CO2}	—	85	ns
Output Enable Access Time	t_{OE}	—	45	ns
\overline{LBs} , \overline{UBs} to Output Valid	t_{BA}	—	85	ns
Chip Enable ($\overline{CE1}$ s Low and CE2s High) to Output Active	t_{COE}	5	—	ns
Output Enable Low to Output Active	t_{OEE}	0	—	ns
\overline{UBs} , \overline{LBs} Enable Low to Output Active	t_{BE}	0	—	ns
Chip Enable ($\overline{CE1}$ s High or CE2s Low) to Output High-Z	t_{OD}	—	35	ns
Output Enable High to Output High-Z	t_{ODO}	—	35	ns
\overline{UBs} , \overline{LBs} Output Enable to Output High-Z	t_{BD}	—	50	ns
Output Data Hold Time	t_{OH}	10	—	ns

Note: Test conditions: Output Load: 1 TTL gate and 30 pF
 Input rise and fall times: 5 ns
 Input pulse levels: 0.0 V to V_{CCS}
 Timing measurement reference level
 Input: $0.5 \times V_{CCS}$
 Output: $0.5 \times V_{CCS}$

MB84VD2118XA-85/MB84VD2119XA-85

• Read Cycle (Note) (SRAM)

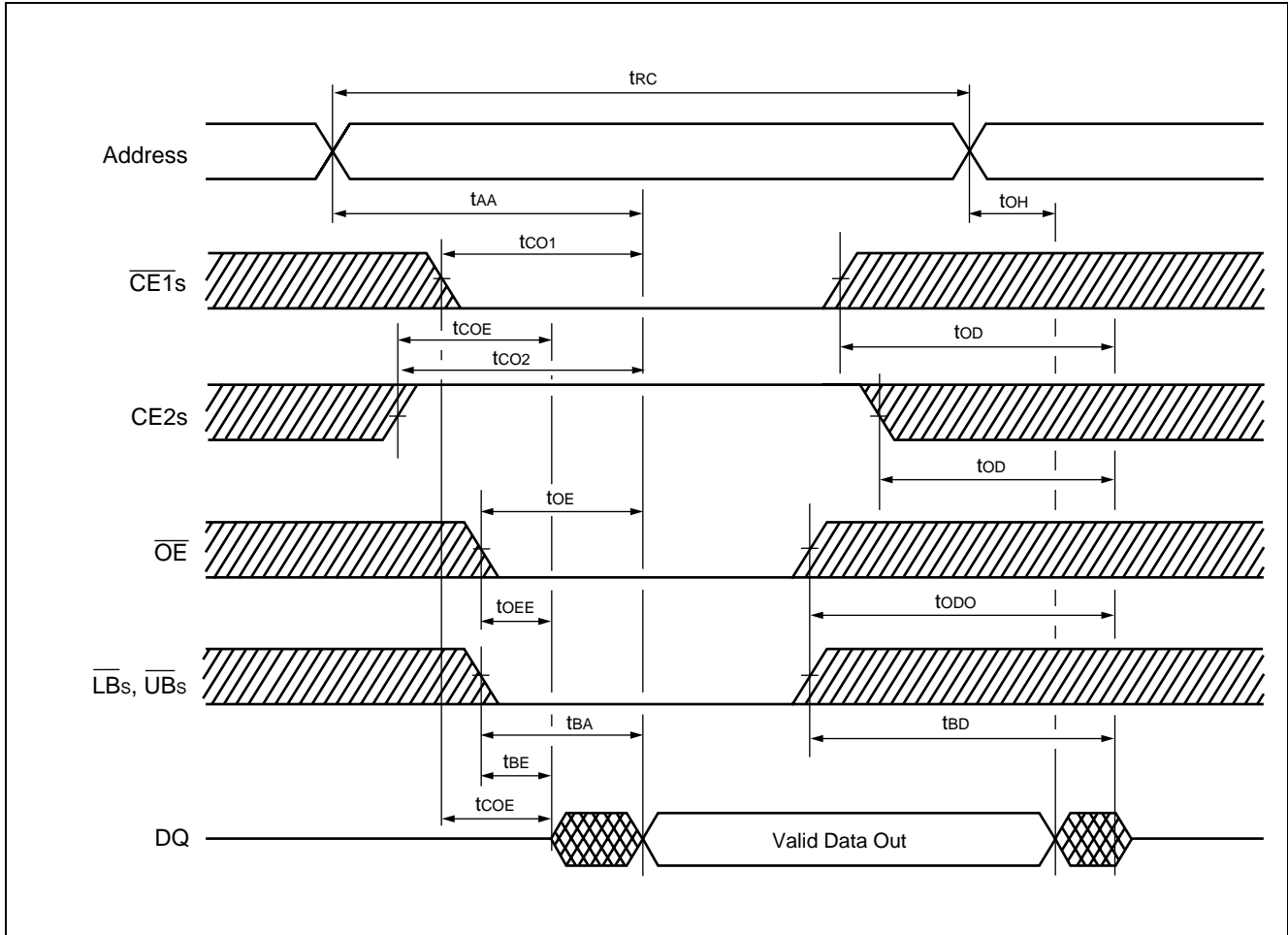

Note : \overline{WE} remains "H" for the read cycle.

MB84VD2118XA-85/MB84VD2119XA-85

• Write Cycle (SRAM)

Parameter	Symbol	Value		Unit
		Min.	Max.	
Write Cycle Time	t _{WC}	85	—	ns
Write Pulse Width	t _{WP}	55	—	ns
Chip Enable to End of Write	t _{CW}	70	—	ns
Address valid to End of Write	t _{AW}	70	—	ns
\overline{UB}_s , \overline{LB}_s to End of Write	t _{BW}	55	—	ns
Address Setup Time	t _{AS}	0	—	ns
Write Recovery Time	t _{WR}	0	—	ns
\overline{WE} Low to Output High-Z	t _{ODW}	—	35	ns
\overline{WE} High to Output Active	t _{OEW}	0	—	ns
Data Setup Time	t _{DS}	35	—	ns
Data Hold Time	t _{DH}	0	—	ns

MB84VD2118XA-85/MB84VD2119XA-85

• Write Cycle (Note 3) (\overline{WE} control) (SRAM)

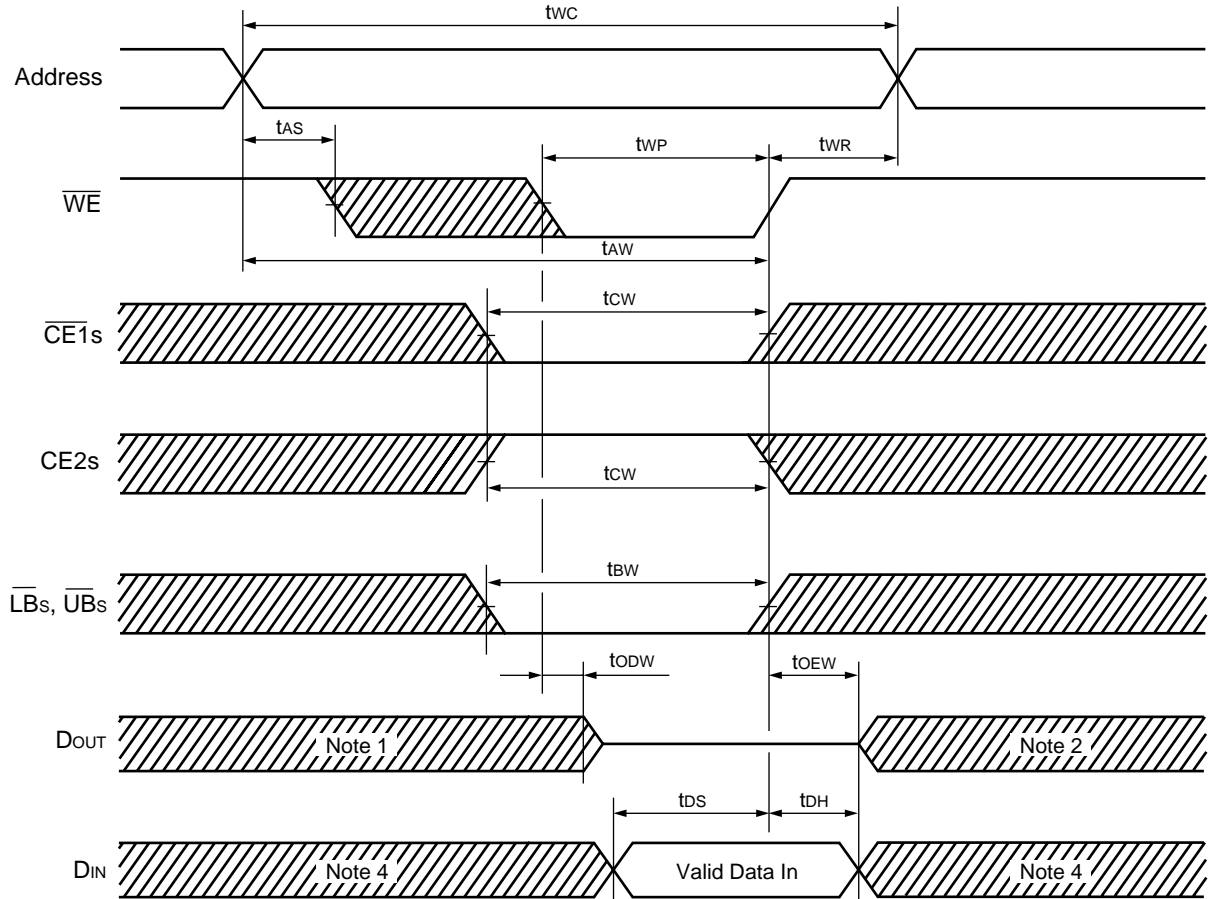

- Notes :
1. If $\overline{CE1s}$ goes "L" (or $CE2s$ goes "H") coincident with or after \overline{WE} goes "L", the output will remain at High-Z.
 2. If $\overline{CE1s}$ goes "H" (or $CE2s$ goes "L") coincident with or before \overline{WE} goes "H", the output will remain at High-Z.
 3. If \overline{OE} is "H" during the write cycle, the outputs will remain at High-Z.
 4. Because I/O signals may be in the output state at this time, input signals of reverse polarity must not be applied.

MB84VD2118XA-85/MB84VD2119XA-85

• Write Cycle (Note 1) ($\overline{\text{CE1s}}$ control) (SRAM)

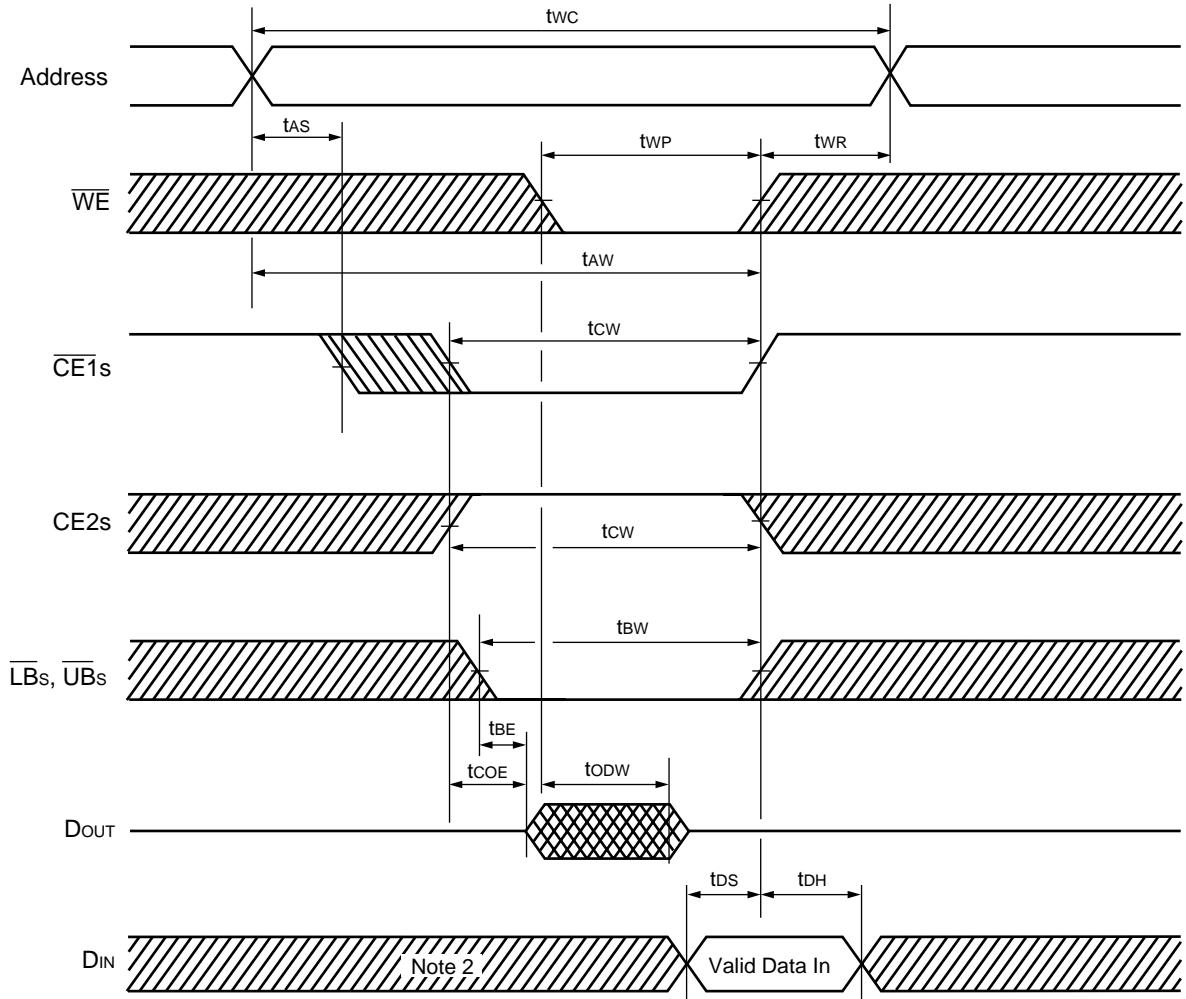

- Notes :
1. If $\overline{\text{OE}}$ is "H" during the write cycle, the outputs will remain at High-Z.
 2. Because I/O signals may be in the output state at this time, input signals of reverse polarity must not be applied.

MB84VD2118XA-85/MB84VD2119XA-85

• Write Cycle (Note 1) (CE2s Control) (SRAM)

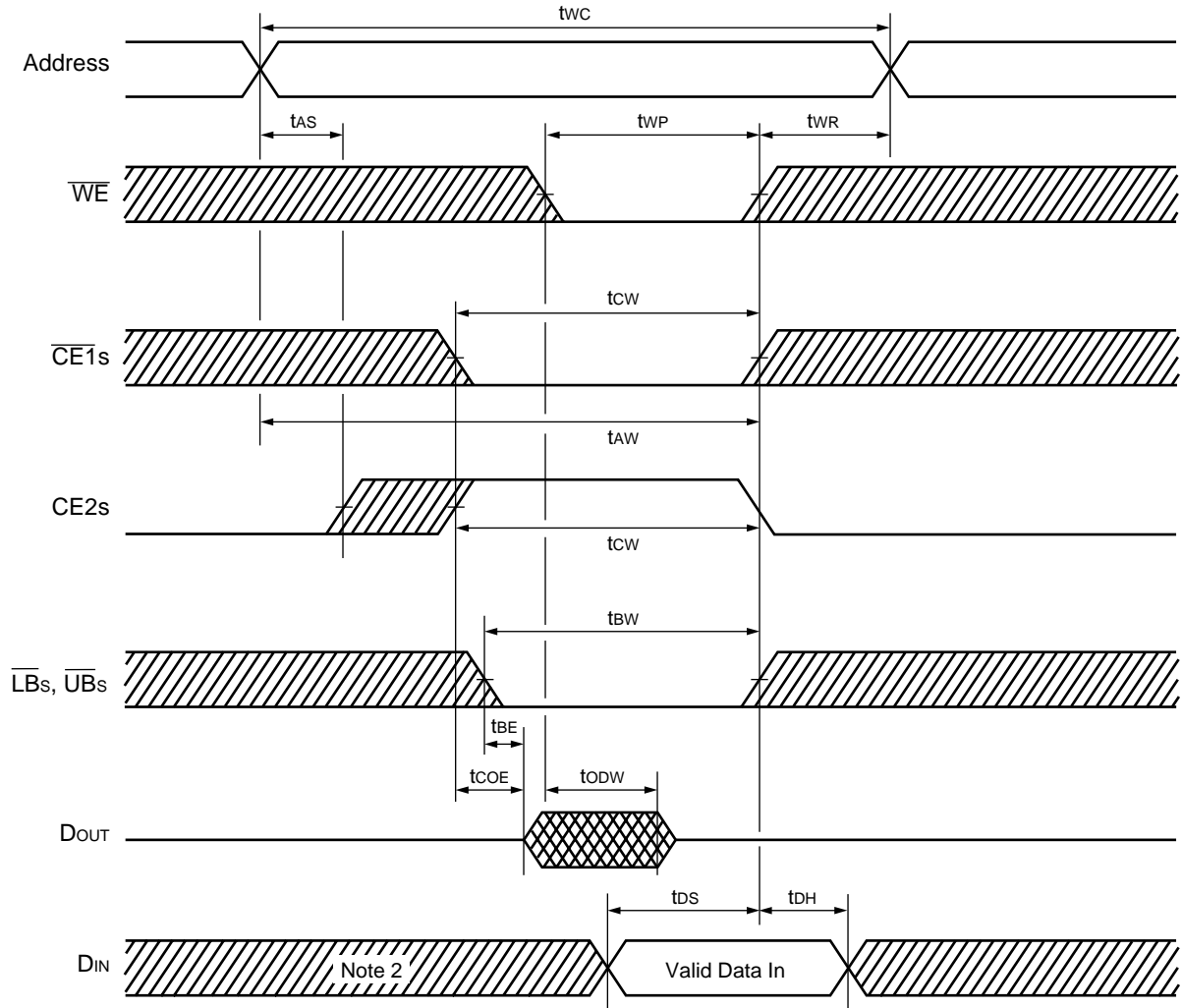

- Notes :
1. If \overline{OE} is "H" during the write cycle, the outputs will remain at High-Z.
 2. Because I/O signals may be in the output state at this time, input signals of reverse polarity must not be applied.

MB84VD2118XA-85/MB84VD2119XA-85

• Write Cycle (Note 1) ($\overline{\text{LBs}}$, $\overline{\text{UBs}}$ Control) (SRAM)

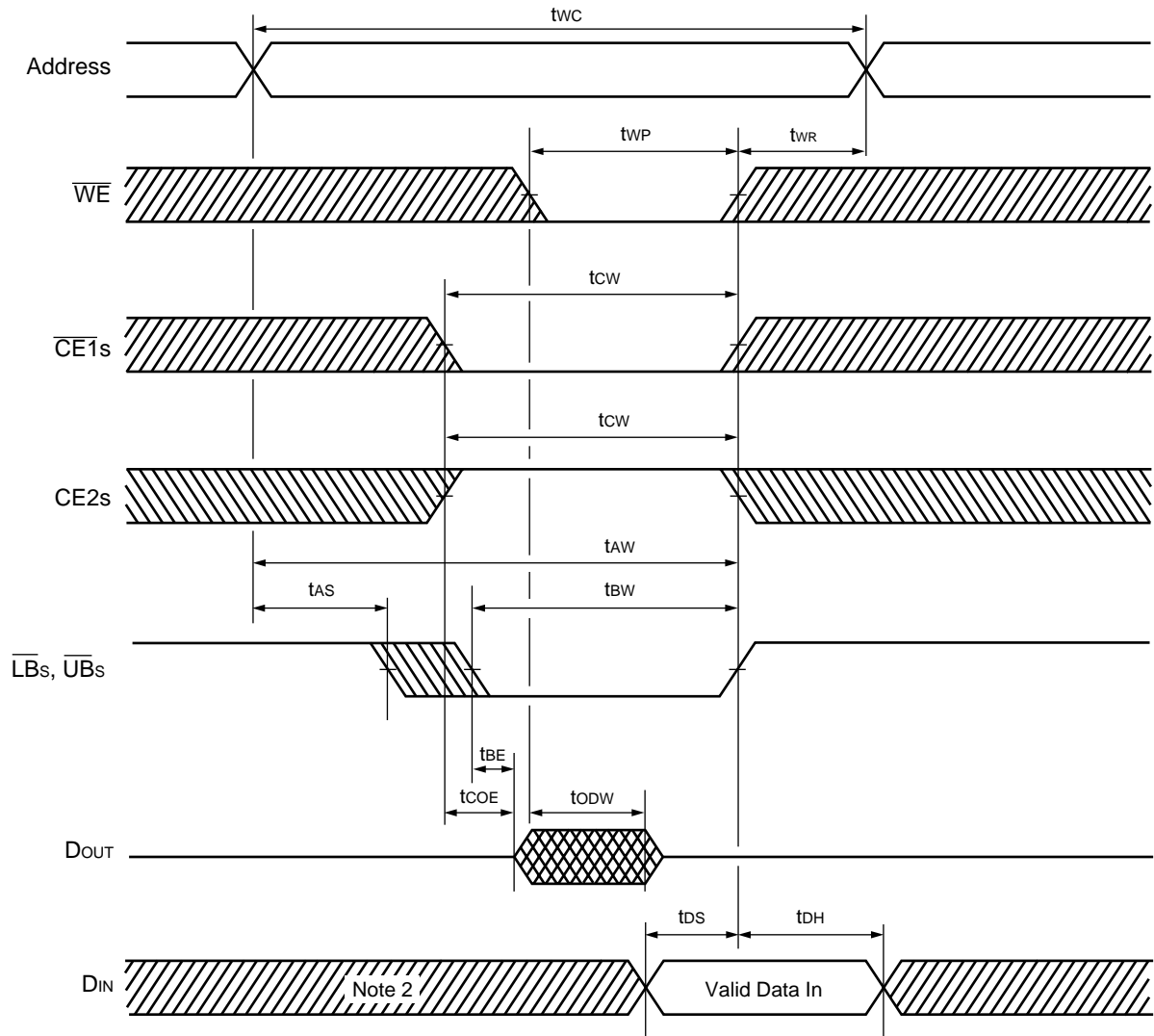

- Notes :
1. If $\overline{\text{OE}}$ is "H" during the write cycle, the outputs will remain at High-Z.
 2. Because I/O signals may be in the output state at this time, input signals of reverse polarity must not be applied.

MB84VD2118XA-85/MB84VD2119XA-85

■ ERASE AND PROGRAMMING PERFORMANCE (Flash)

Parameter	Limits			Unit	Comment
	Min.	Typ.	Max.		
Sector Erase Time	—	1	10	s	Excludes programming time prior to erasure
Byte Programming Time	—	8	300	μs	Excludes system-level overhead
Word Programming Time	—	16	360	μs	Excludes system-level overhead
Chip Programming Time	—	—	50	s	Excludes system-level overhead
Erase/Program Cycle	100,000	—	—	cycle	

■ DATA RETENTION CHARACTERISTICS (SRAM)

Parameter	Symbol	Value			Unit
		Min.	Typ.	Max.	
Data Retention Supply Voltage	V_{DH}	1.5	—	3.6	V
Standby Current	I_{DDs2}	—	0.2	7*	μA
Chip Deselect to Data Retention Mode Time	t_{CDR}	0	—	—	ns
Recovery Time	t_R	t_{RC}	—	—	ns

* : 4 μA Max. at $T_A \leq 60^\circ\text{C}$, 1 μA Max. at $T_A \leq 40^\circ\text{C}$

Note : t_{RC} : Read cycle time

• $\overline{CE1s}$ Controlled Data Retention Mode (Note 1)

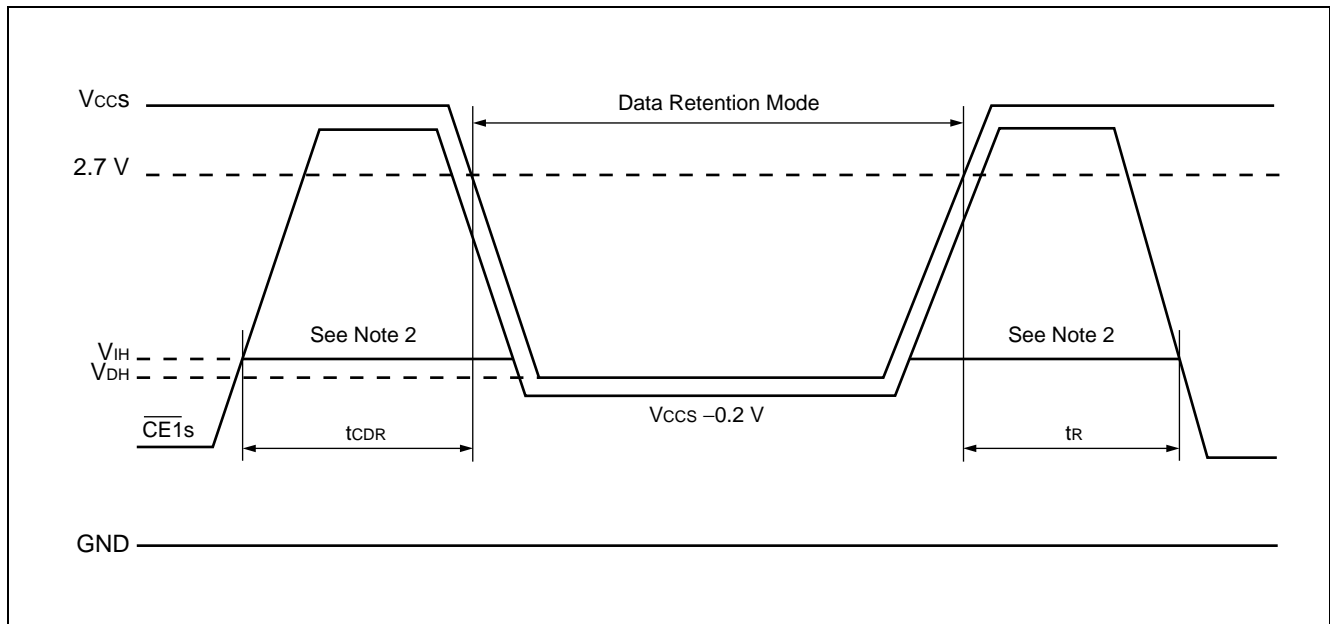

MB84VD2118XA-85/MB84VD2119XA-85

• CE2s Controlled Data Retention Mode (Note 3)

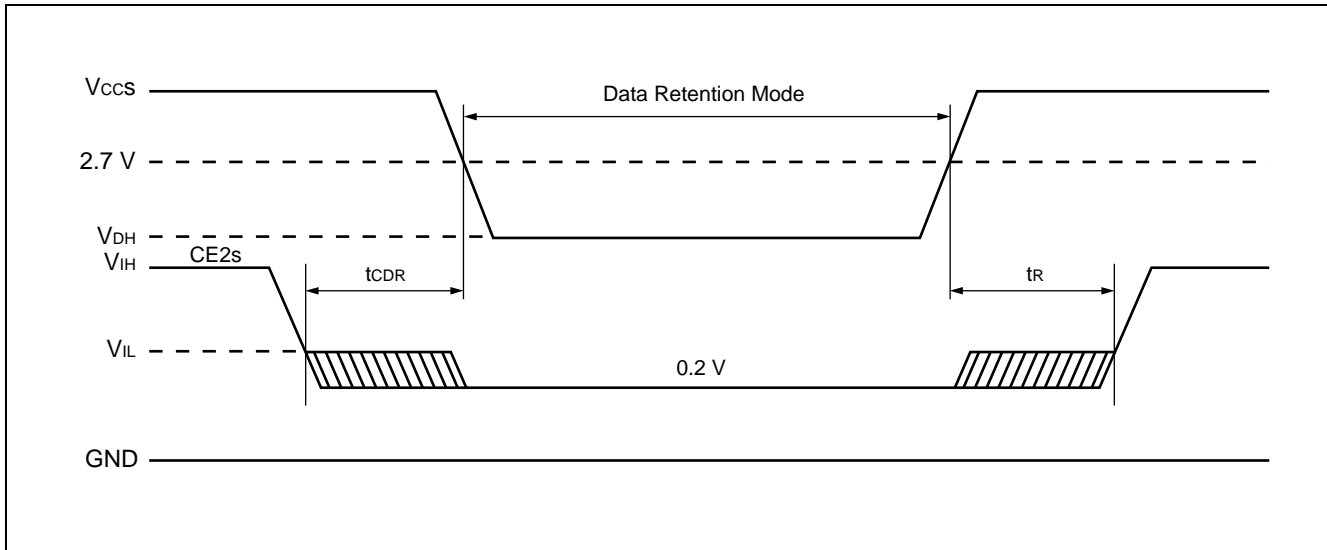

- Notes :
1. In $\overline{CE1}$ s controlled data retention mode, input level of CE2s should be fixed V_{CCS} to $V_{CCS} - 0.2\text{ V}$ or V_{SS} to 0.2 V during data retention mode. Other input and input/output pins can be used between -0.3 V and $V_{CCS} + 0.3\text{ V}$.
 2. When $\overline{CE1}$ s is operating at the V_{IH} Min. level (2.2 V), the standby current is given by I_{SB1S} during the transition of V_{CCS} from 3.6 to 2.2 V .
 3. In CE2s controlled data retention mode, input and input/output pins can be used between -0.3 V and $V_{CCS} + 0.3\text{ V}$.

■ PIN CAPACITANCE

Parameter	Symbol	Test Setup	Value		Unit
			Typ.	Max.	
Input Capacitance	C_{IN}	$V_{IN} = 0$	11	14	pF
Output Capacitance	C_{OUT}	$V_{OUT} = 0$	12	16	pF
Control Pin Capacitance	C_{IN2}	$V_{IN} = 0$	14	16	pF
\overline{WP}/ACC Pin Capacitance	C_{IN3}	$V_{IN} = 0$	17	20	pF

Note : Test conditions $T_A = 25\text{ }^\circ\text{C}$, $f = 1.0\text{ MHz}$

■ HANDLING OF PACKAGE

Please handle this package carefully since the sides of packages are right angle.

■ CAUTION

1. The high voltage (V_{ID}) can not apply to address pins and control pins except \overline{RESET} . Therefore, it can not use autoselect and sector protect function by applying the high voltage (V_{ID}) to specific pins.
2. For the sector protection, since the high voltage (V_{ID}) can be applied to the \overline{RESET} , it can be protected the sector using "Extended sector protect" command.

MB84VD2118XA-85/MB84VD2119XA-85

■ ORDERING INFORMATION

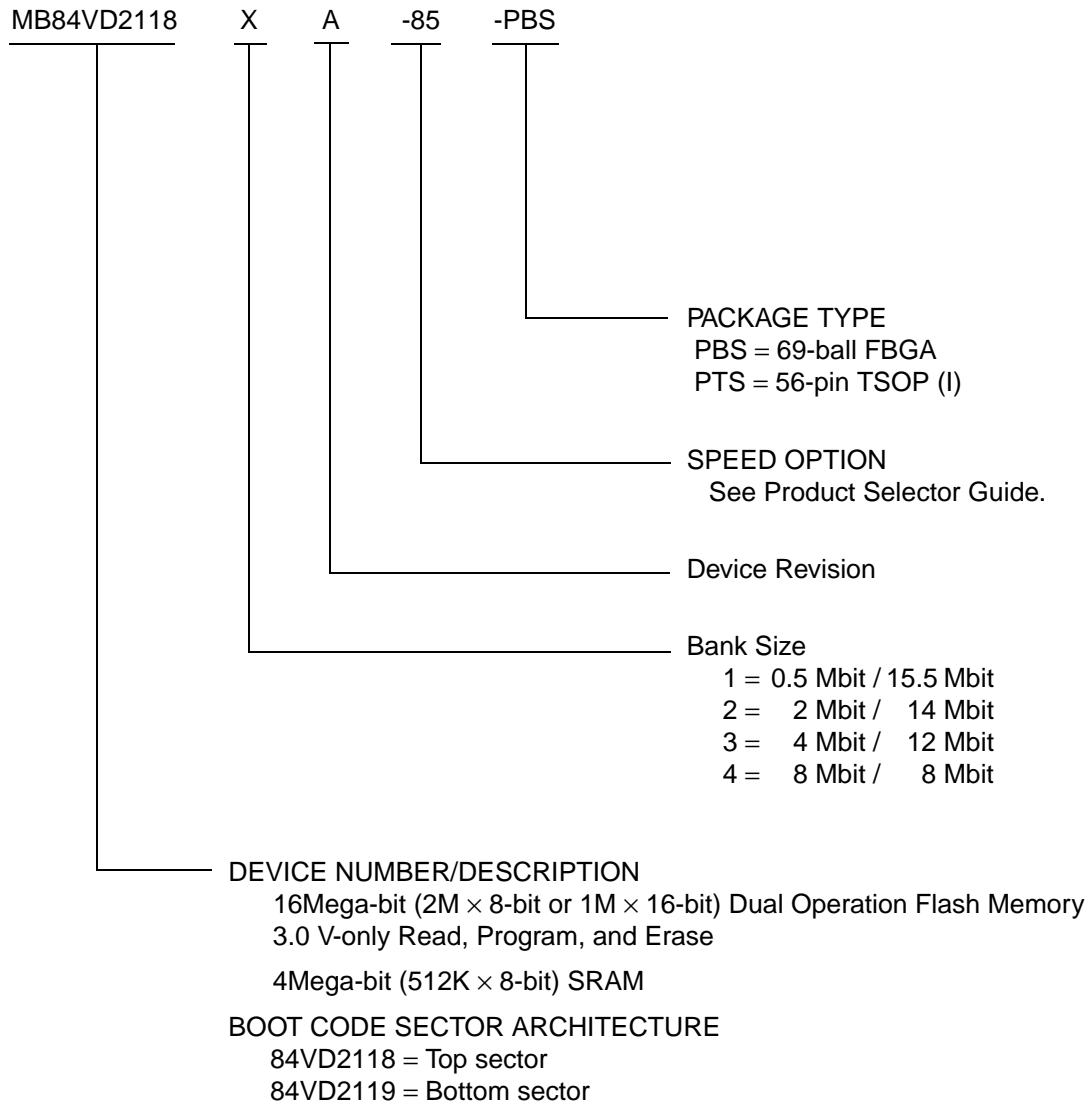

MB84VD2118XA-85/MB84VD2119XA-85

PACKAGE DIMENSIONS

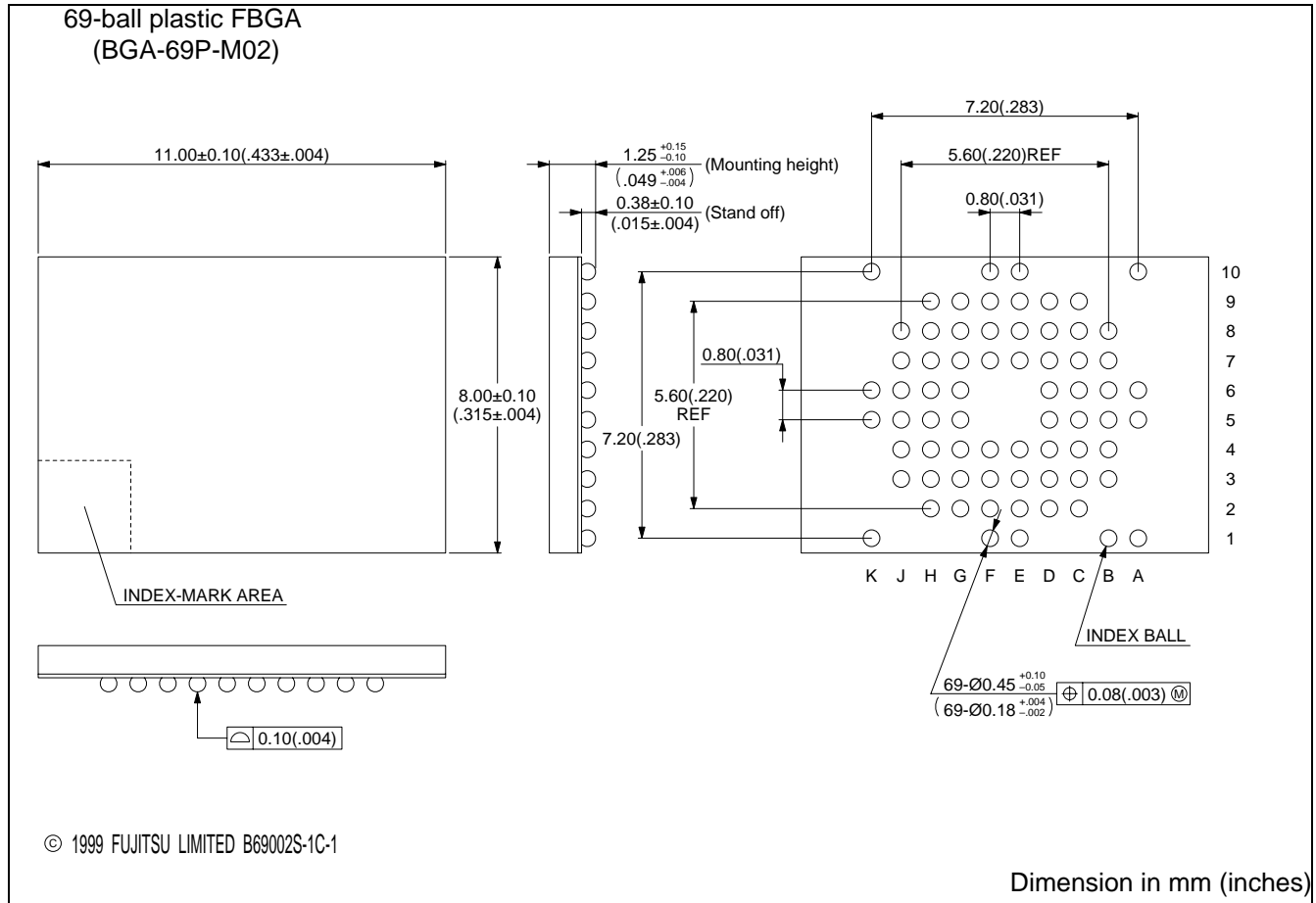

(Continued)

MB84VD2118XA-85/MB84VD2119XA-85

(Continued)

56-pin plastic TSOP (I)
(FPT-56P-M04)

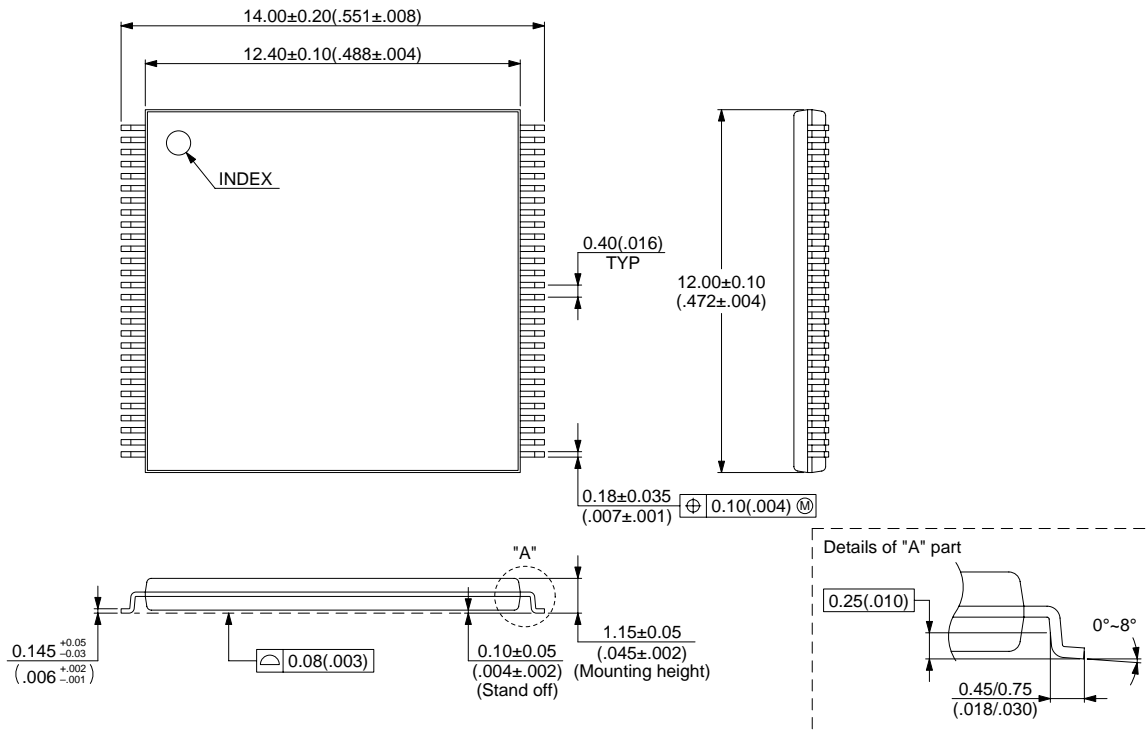

© 1998 FUJITSU LIMITED F56004S-1C-1

Dimension in mm (inches)

FUJITSU LIMITED

For further information please contact:

Japan

FUJITSU LIMITED
Corporate Global Business Support Division
Electronic Devices
Shinjuku Dai-Ichi Seimei Bldg. 7-1,
Nishishinjuku 2-chome, Shinjuku-ku,
Tokyo 163-0721, Japan
Tel: +81-3-5322-3347
Fax: +81-3-5322-3386

<http://edevice.fujitsu.com/>

North and South America

FUJITSU MICROELECTRONICS, INC.
3545 North First Street,
San Jose, CA 95134-1804, U.S.A.
Tel: +1-408-922-9000
Fax: +1-408-922-9179

Customer Response Center
Mon. - Fri.: 7 am - 5 pm (PST)
Tel: +1-800-866-8608
Fax: +1-408-922-9179

<http://www.fujitsumicro.com/>

Europe

FUJITSU MICROELECTRONICS EUROPE GmbH
Am Siebenstein 6-10,
D-63303 Dreieich-Buchsschlag,
Germany
Tel: +49-6103-690-0
Fax: +49-6103-690-122

<http://www.fujitsu-fme.com/>

Asia Pacific

FUJITSU MICROELECTRONICS ASIA PTE. LTD.
#05-08, 151 Lorong Chuan,
New Tech Park,
Singapore 556741
Tel: +65-281-0770
Fax: +65-281-0220

<http://www.fmap.com.sg/>

Korea

FUJITSU MICROELECTRONICS KOREA LTD.
1702 KOSMO TOWER, 1002 Daechi-Dong,
Kangnam-Gu, Seoul 135-280
Korea
Tel: +82-2-3484-7100
Fax: +82-2-3484-7111

F0104

© FUJITSU LIMITED Printed in Japan

All Rights Reserved.

The contents of this document are subject to change without notice. Customers are advised to consult with FUJITSU sales representatives before ordering.

The information and circuit diagrams in this document are presented as examples of semiconductor device applications, and are not intended to be incorporated in devices for actual use. Also, FUJITSU is unable to assume responsibility for infringement of any patent rights or other rights of third parties arising from the use of this information or circuit diagrams.

The products described in this document are designed, and manufactured as contemplated for general use, including without limitation, ordinary industrial use, general office use, personal use, and household use, but are not designed, developed and manufactured as contemplated (1) for use accompanying fatal risks or dangers that, unless extremely high safety is secured, could have a serious effect to the public, and could lead directly to death, personal injury, severe physical damage or other loss (i.e., nuclear reaction control in nuclear facility, aircraft flight control, air traffic control, mass transport control, medical life support system, missile launch control in weapon system), or (2) for use requiring extremely high reliability (i.e., submersible repeater and artificial satellite).

Please note that Fujitsu will not be liable against you and/or any third party for any claims or damages arising in connection with above-mentioned uses of the products.

Any semiconductor devices have inherently a certain rate of failure. You must protect against injury, damage or loss from such failures by incorporating safety design measures into your facility and equipment such as redundancy, fire protection, and prevention of over-current levels and other abnormal operating conditions.

If any products described in this document represent goods or technologies subject to certain restrictions on export under the Foreign Exchange and Foreign Trade Control Law of Japan, the prior authorization by Japanese government should be required for export of those products from Japan.