

Optical Components

OL3450L-A,OL3451L-A,OL3453L-A OL4450L-A,OL4451L-A,OL4453L-A OL4450L-B,OL4451L-B,OL4453L-B OL5450L-A,OL5451L-A,OL5453L-A OL5450L-B,OL5451L-B,OL5453L-B OL6450L-A,OL6451L-A,OL6453L-A Series

2mW Coaxial DFB Laser Diode Modules

1. DESCRIPTION

The OL3450L-A, OL3451L-A, OL3453L-A, OL4450L-A, OL4451L-A, OL4453L-A, OL4450L-B, OL4451L-B, OL4453L-B, OL5450L-A, OL5451L-A, OL5453L-A, OL5450L-B, OL5451L-B, OL5453L-B, OL6450L-A, OL6451L-A, OL6453L-A series consist of an MQW-DFB laser diode, a monitor PD, a single-stage optical isolator, a single-mode fiber and a coaxial package.

2. FEATURES

- High output power: 2.0mW fiber output power under CW
- Wide operating temperature range: Tc=0 to +70°C
- Side-mode suppression: 30dB
- Multi-quantum-well (MQW) DFB structure
- Internal monitor PD for power control
- Built-in single-stage optical isolator
- Coaxial Package
- No TEC required

3. APPLICATION

- WDM supervisory channel in SDH system with optical in-line amplifier

4.OPTICAL AND ELECTRICAL CHARACTERISTICS

(Tc = 0 to +70°C, unless otherwise specified)

Parameter	Symbol	Test Conditions	Min.	Typ.	Max.	Unit	
Fiber Output Power	Pf	CW	2.0			mW	
Threshold Current	Ith	Tc=+25°C,CW		10	35	mA	
		Tc=+70°C,CW		27	40		
Operation Current	Iop	Pf=2.0mW,CW		50	120	mA	
Forward Voltage	Vf	Pf=2.0mW,CW		1.1	1.5	V	
Peak Wavelength	λ_p	Pf=2.0mW ,CW	OL345xL-A	1300	1310	1320	nm
			OL445xL-A	1470	1480	1490	
			OL445xL-B	1480	1490	1500	
			OL545xL-A	1500	1510	1520	
			OL545xL-B	1510	1520	1530	
			OL645xL-A-S1	1620	1630	1640	
			OL645xL-A-S2	1625	1630	1645	
Side-mode suppression ratio	SMSR	Pf=2.0mW,CW, Tc=+25°C	30			dB	
Rise/Fall times	Tr/Tf	Pf =2.0mW,Ibias=Ith 10-90%			0.5	ns	
Photodiode Dark Current	Id	Vrd=5V, Tc=+25°C			20	nA	
Monitor Current	Im	Pf=2.0mW,CW,Tc=+25°C	50			μ A	
Tracking Error*	TRE	(RT to WCT)	-1	---	+1	dB	

*TRE=10*log{(Pf@0~+70°C)/(Pf@25°C)} at Im hold(@25°C)

5.ABSOLUTE MAXIMUM RATING

(Tc = +25°C, unless otherwise specified)

Parameter	Symbol	Rating	Unit
Fiber Output Power	Pf	3	mW
LD Reverse Voltage	Vrl	2	V
Monitor PD Forward Current	Ifd	10	mA
Monitor PD Reverse Current	Ird	3	mA
Monitor PD Reverse Voltage	Vrd	15	V
Operating Case Temperature (Tc)	Tc	0 to +70	°C
Storage Temperature	Tstg	-40 to +85	°C
Lead Soldering Temperature (10s)	-	260	°C

6.CONNECTOR AND FIBER SPECIFICATIONS

Parameter	Specifications	Unit
Type	SM	---
Mode Field Diameter	9+/-1	μm
Cladding Diameter	125+/-2	μm
Jacket Diameter	900	μm
Length	1(Min)	m
Connector Type	FC/SC/LC/MU/MU-J	---

7.ORDERING INFORMATION

OL 6 45 0 L - A - AF SC - S1

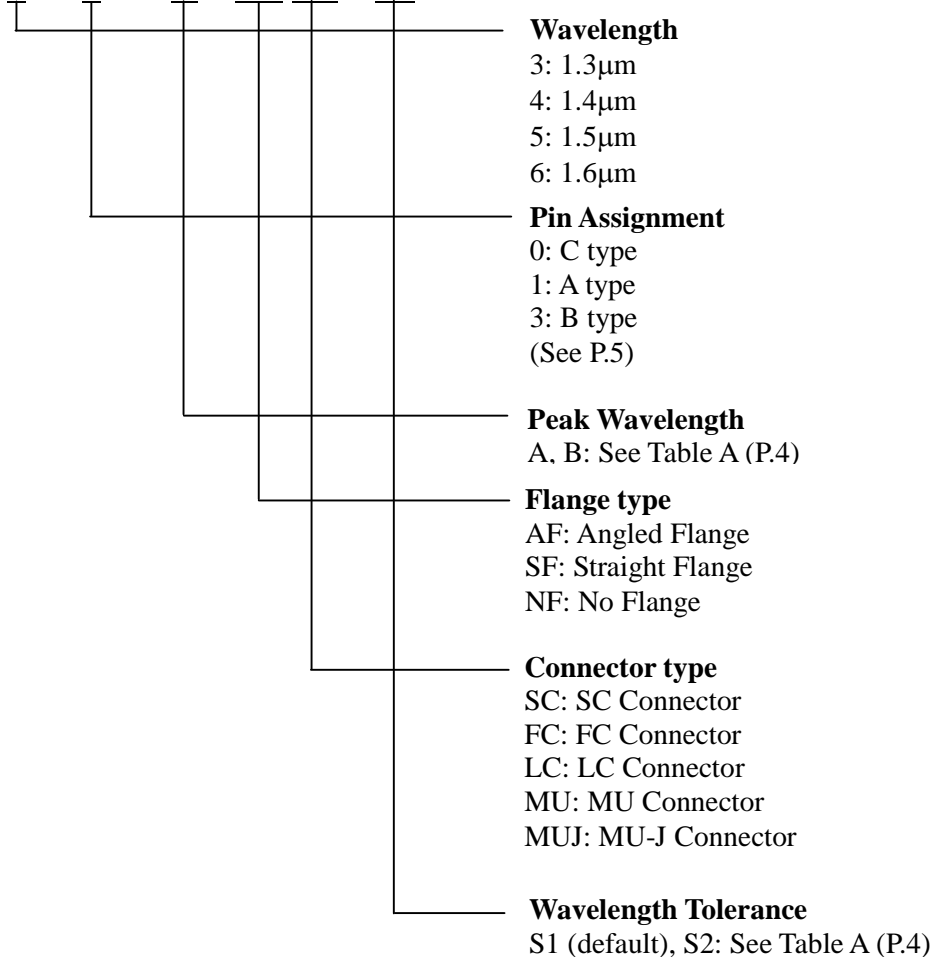
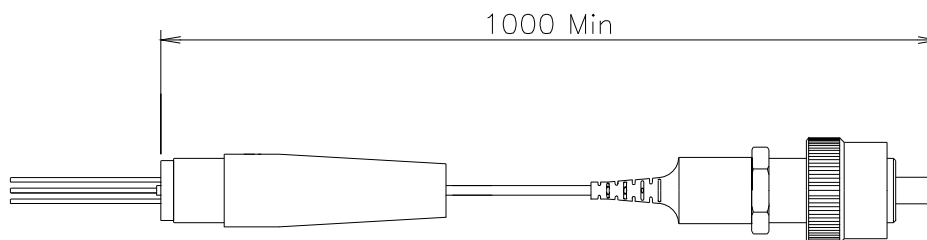

Table A. Peak Wavelength vs. Oki Part Number

Peak Wavelength(Typ.)	Wavelength Tolerance	Oki Part Number
1310nm	+/-10nm	OL345xL-A
1480nm	+/-10nm	OL445xL-A
1490nm	+/-10nm	OL445xL-B
1510nm	+/-10nm	OL545xL-A
1520nm	+/-10nm	OL545xL-B
1630nm	+/-10nm	OL645xL-A-S1
1630nm	+15/-5nm	OL645xL-A-S2

8.OUTLINE DRAWING

Length (mm)



All dimensions in millimeters

Flange Type

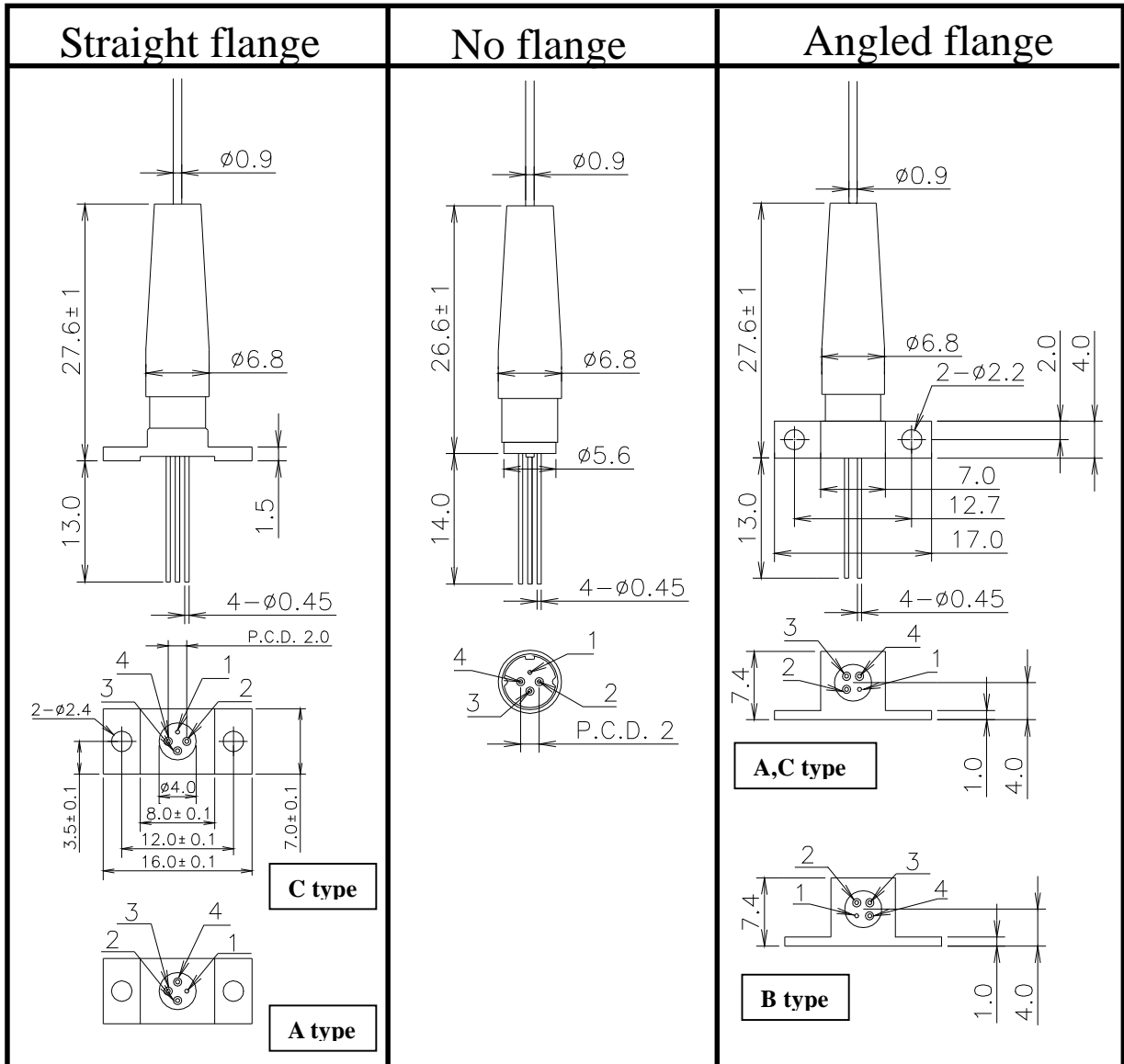

Pin Assignment

OL6450L (C type)	OL6451L (A type)	OL6453L (B type)																																				
<table border="1"> <tr><td colspan="2">PIN configuration</td></tr> <tr><td colspan="2">Assignment</td></tr> <tr><td>1</td><td>CASE</td></tr> <tr><td>2</td><td>LD cathode</td></tr> <tr><td>3</td><td>PD anode</td></tr> <tr><td>4</td><td>LD anode PD cathode</td></tr> </table>	PIN configuration		Assignment		1	CASE	2	LD cathode	3	PD anode	4	LD anode PD cathode	<table border="1"> <tr><td colspan="2">PIN configuration</td></tr> <tr><td colspan="2">Assignment</td></tr> <tr><td>1</td><td>LD anode (CASE)</td></tr> <tr><td>2</td><td>LD cathode</td></tr> <tr><td>3</td><td>PD cathode</td></tr> <tr><td>4</td><td>PD anode</td></tr> </table>	PIN configuration		Assignment		1	LD anode (CASE)	2	LD cathode	3	PD cathode	4	PD anode	<table border="1"> <tr><td colspan="2">PIN configuration</td></tr> <tr><td colspan="2">Assignment</td></tr> <tr><td>1</td><td>LD anode (CASE)</td></tr> <tr><td>2</td><td>PD anode</td></tr> <tr><td>3</td><td>PD cathode</td></tr> <tr><td>4</td><td>LD cathode</td></tr> </table>	PIN configuration		Assignment		1	LD anode (CASE)	2	PD anode	3	PD cathode	4	LD cathode
PIN configuration																																						
Assignment																																						
1	CASE																																					
2	LD cathode																																					
3	PD anode																																					
4	LD anode PD cathode																																					
PIN configuration																																						
Assignment																																						
1	LD anode (CASE)																																					
2	LD cathode																																					
3	PD cathode																																					
4	PD anode																																					
PIN configuration																																						
Assignment																																						
1	LD anode (CASE)																																					
2	PD anode																																					
3	PD cathode																																					
4	LD cathode																																					

9. SAFETY INFORMATION ON THIS PRODUCT



PEAK OUTPUT POWER 500mW
 WAVELENGTH 900~1700nm
 CLASS 3B LASER PRODUCT

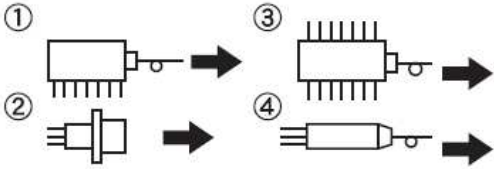

AVOID EXPOSURE
 Laser invisible radiation is emitted from the aperture.

Complies with CFR1040.10 and IEC60825-1

<p>Warning</p> <p>Laser Beam</p>	<p>A laser beam is emitted from this laser diode during operation. The invisible or visible laser beam, directly or indirectly, may cause injury to the eye or loss of eyesight.</p> <p>Do not look directly into the laser beam.</p> <p>Avoid exposure to the laser beam, any reflected or collimated beam.</p>
<p>Caution</p> <p>GaAs Product</p>	<p>The product contains gallium arsenide, GaAs. GaAs vapor and powder are hazardous to human health if inhaled, ingested or swallowed.</p> <p>Do not destroy or burn the product.</p> <p>Do not crush or chemically dissolve the product.</p> <p>Do not put the product in the mouth.</p> <p>Observe related laws and company regulations when discarding this product. The product should be excluded from general industrial waste or household garbage.</p>
<p>Caution</p> <p>Optical Fiber</p>	<p>A glass-fiber is attached on the product. Handle with care.</p> <p>When the fiber is broken or damaged, handle carefully to avoid injury from the damaged part or fragments.</p>

All specifications described herein are subject to change without notice.

Notice

1. The information contained herein can change without notice owing to product and/or technical improvements. Before using the product, please make sure that the information being referred to is up-to-date.
2. The outline of action and examples for application circuits described herein have been chosen as an explanation for the standard action and performance of the product. When planning to use the product, please ensure that the external conditions are reflected in the actual circuit, assembly, and program designs.
3. When designing your product, please use our product below the specified maximum ratings and within the specified operating ranges including, but not limited to, operating voltage, power dissipation, and operating temperature.
4. OKI SEMICONDUCTOR assumes no responsibility or liability whatsoever for any failure or unusual or unexpected operation resulting from misuse, neglect, improper installation, repair, alteration or accident, improper handling, or unusual physical or electrical stress including, but not limited to, exposure to parameters beyond the specified maximum ratings or operation outside the specified operating range.
5. Neither indemnity against nor license of a third party's industrial and intellectual property right, etc. is granted by us in connection with the use of the product and/or the information and drawings contained herein. No responsibility is assumed by us for any infringement of a third party's right which may result from the use thereof.
6. The products listed in this document are intended for use in general electronics equipment for commercial applications (e.g., office automation, communication equipment, measurement equipment, consumer electronics, etc.). These products are not authorized for use in any system or application that requires special or enhanced quality and reliability characteristics nor in any system or application where the failure of such system or application may result in the loss or damage of property, or death or injury to humans. Such applications include, but are not limited to, traffic and automotive equipment, safety devices, aerospace equipment, nuclear power control, medical equipment, and life-support systems.
7. Certain products in this document may need government approval before they can be exported to particular countries. The purchaser assumes the responsibility of determining the legality of export of these products and will take appropriate and necessary steps at their own expense for these.
8. No part of the contents contained herein may be reprinted or reproduced without our prior permission.

Copyright 2008 OKI SEMICONDUCTOR CO., LTD.