

EC26 Series

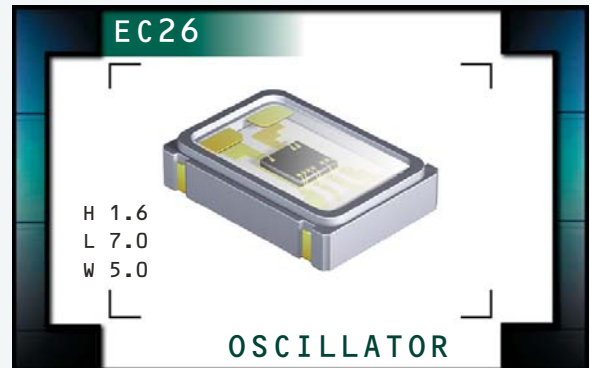

ECLIPTEK[®]
CORPORATION

- RoHS Compliant (Pb-Free)
- Ceramic SMD package
- 3.3V supply voltage
- LVHCMOS/TTL output
- Stability to 20ppm
- Standby Function
- Available in tube or tape and reel



ELECTRICAL SPECIFICATIONS

Frequency Range	1.544MHz to 125.000MHz and 125.009MHz, 125.009375MHz, 125.010MHz, 127MHz, 128MHz, 130MHz, 132MHz, 133MHz, 133.333MHz, 137.472MHz, 142.850MHz, 150MHz, 155.520MHz and 156.250MHz	
Operating Temperature Range	Frequency Tolerance/Stability options of ± 100 ppm, ± 50 ppm, ± 25 ppm, ± 20 ppm available	-10°C to 70°C
	Frequency Tolerance/Stability options of ± 100 ppm, ± 50 ppm, ± 25 ppm available	-40°C to 85°C
	Frequency Tolerance/Stability option of ± 20 ppm available from 1.544MHz to 106.250MHz	-40°C to 85°C
Storage Temperature Range		-55°C to 125°C
Supply Voltage (V_{DD})		3.3V _{DC} $\pm 10\%$
Input Current	1.544MHz to 32.000MHz	10mA Maximum
	32.000001MHz to 50.000MHz	18mA Maximum
	50.000001MHz to 70.000MHz	20mA Maximum
	70.000001MHz to 125.000MHz	40mA Maximum
	125.009MHz to 156.250MHz	60mA Maximum
Frequency Tolerance / Stability	Inclusive of all conditions: Calibration Tolerance at 25°C, Frequency Stability over the Operating Temperature Range, Supply Voltage Change, Output Load Change, First Year Aging at 25°C, Shock, and Vibration	± 100 ppm Maximum ± 50 ppm Maximum ± 25 ppm Maximum ± 20 ppm Maximum
Output Voltage Logic High (V_{OH})	w/HCMOS or TTL Load, I _{OH} = -8mA	90% of V _{DD} Minimum
Output Voltage Logic Low (V_{OL})	w/HCMOS or TTL Load, I _{OL} = +8mA	10% of V _{DD} Maximum
Rise / Fall Time	10% to 90% of Waveform w/15pF HCMOS Load or 0.4V _{DC} to 2.4V _{DC} w/10LSTTL Load ≤ 35.000 MHz	5 nSeconds Maximum
	10% to 90% of Waveform w/30pF HCMOS Load or 0.4V _{DC} to 2.4V _{DC} w/10TTL Load ≤ 35.000 MHz	7 nSeconds Maximum
	10% to 90% of Waveform w/HCMOS Load or 0.4V _{DC} to 2.4V _{DC} w/TTL Load 35.001MHz to 125.000MHz	5 nSeconds Maximum
	10% to 90% of Waveform w/HCMOS Load > 125.009 MHz	3 nSeconds Maximum
Duty Cycle	at 50% of Waveform w/HCMOS Load or 1.4V _{DC} w/TTL Load ≤ 70.000 MHz	50 ± 10 (%) (Standard)
	at 50% of Waveform w/HCMOS Load > 70.000 MHz	50 ± 10 (%) (Standard)
	at 50% of waveform w/HCMOS Load or w/TTL Load ≤ 125.000 MHz	50 ± 5 (%) (Optional)
	at 50% of waveform w/HCMOS Load, at 25°C, at 3.3Vdc > 125.000 MHz	50 ± 5 (%) (Optional)
Load Drive Capability	≤ 35.000 MHz	10TTL or 30pF HCMOS Load Max.
	35.000001MHz to 70.000MHz	10TTL or 15pF HCMOS Load Max.
	> 70.000001 MHz	15pF HCMOS Load Maximum
Tri-State Input Voltage	No Connection	Enables Output
	V _{IH} : $\geq 70\%$ of V _{DD}	Enables Output
	V _{IL} : $\leq 30\%$ of V _{DD}	Disables Output: High Impedance
Standby Current	Disabled Output: High Impedance	10 μ A Maximum
Start Up Time		10 mSeconds Maximum
RMS Phase Jitter	12kHz to 20MHz offset frequency	1pSeconds Maximum

MANUFACTURER ECLIPTEK CORP.	CATEGORY OSCILLATOR	SERIES EC26	PACKAGE CERAMIC	VOLTAGE 3.3V	CLASS OS30	REV. DATE 01/06
--------------------------------	------------------------	----------------	--------------------	-----------------	---------------	--------------------

PART NUMBERING GUIDE

EC26 00 ET TTS - 40.000M TR

FREQUENCY TOLERANCE / STABILITY

00=±100ppm Maximum (Standard)
 45=±50ppm Maximum, 25=±25ppm Maximum
 20=±20ppm Maximum

OPERATING TEMPERATURE RANGE

Blank=-10°C to 70°C (Standard)
 ET=-40°C to 85°C

PACKAGING OPTIONS

Blank=Bulk, TR=Tape and Reel (Standard)

FREQUENCY

OUTPUT CONTROL FUNCTION

TS=Tri-State

DUTY CYCLE

Blank=50±10% (Standard), T=50±5%

MECHANICAL DIMENSIONS

ALL DIMENSIONS IN MILLIMETERS

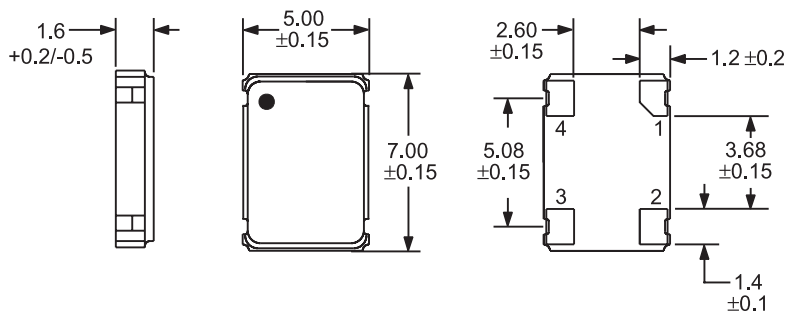

Pin 1: Tri-State
 Pin 2: Case Ground
 Pin 3: Output
 Pin 4: Supply Voltage

SUGGESTED SOLDER PAD LAYOUT

ALL DIMENSIONS IN MILLIMETERS

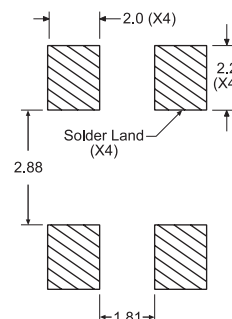

Tolerances = ±0.1

TAPE AND REEL DIMENSIONS

ALL DIMENSIONS IN MILLIMETERS

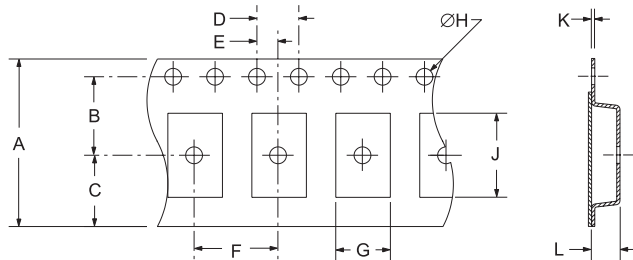

TAPE	A	B	C	D	E
	16+3-.1	7.5±.1	6.75±.1	4±.1	2±.1
F	G	H	J	K	L
8±.1	B0*	1.5+1-0	A0*	.3±.05	K0*

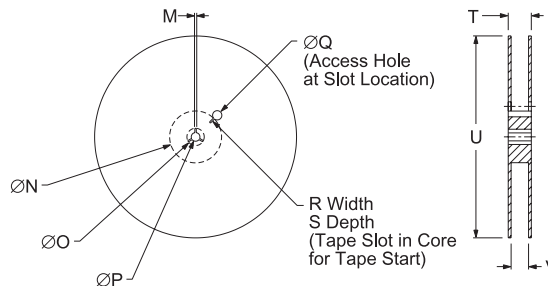

REEL	M	N	O	P	Q
	1.5 MIN	50 MIN	20.2 MIN	13±.2	40 MIN
R	S	T	U	V	QTY/REEL
2.5 MIN	10 MIN	22.4 MAX	360 MAX	16.4+2-0	1,000

*Compliant to EIA 481A

ENVIRONMENTAL/MECHANICAL SPECIFICATIONS

Characteristic

Fine Leak Test
 Gross Leak Test
 Mechanical Shock
 Vibration
 Solderability
 Temperature Cycling
 Resistance to Soldering Heat
 Resistance to Solvents

Specification

MIL-STD-883, Method 1014, Condition A
 MIL-STD-883, Method 1014, Condition C
 MIL-STD-202, Method 213, Condition C
 MIL-STD-883, Method 2007, Condition A
 MIL-STD-883, Method 2002
 MIL-STD-883, Method 1010
 MIL-STD-202, Method 210
 MIL-STD-202, Method 215

MARKING SPECIFICATIONS

Line 1: ECLIPTEK

Line 2: XX.XXX M

Frequency in MHz (5 Digits Maximum + Decimal)

Line 3: XX Y ZZ

Week of Year
 Last Digit of Year
 Ecliptek Manufacturing Identifier

MANUFACTURER	CATEGORY	SERIES	PACKAGE	VOLTAGE	CLASS	REV. DATE
ECLIPTEK CORP.	OSCILLATOR	EC26	CERAMIC	3.3V	OS30	01/06