

2SD1624

■ Features

- Low collector-to-emitter saturation voltage.
- Fast switching speed.

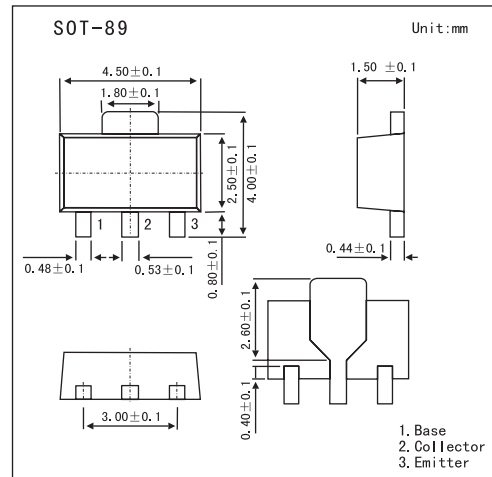

■ Absolute Maximum Ratings Ta = 25°C

Parameter	Symbol	Rating	Unit
Collector-base voltage	V _{CB0}	60	V
Collector-emitter voltage	V _{CEO}	50	V
Emitter-base voltage	V _{EBO}	6	V
Collector current	I _C	3	A
Collector current (pulse)	I _{CP}	6	A
Collector dissipation	P _C	500	mW
	P _C *	1.5	W
Junction temperature	T _J	150	°C
Storage temperature	T _{stg}	-55 to +150	°C

* Mounted on ceramic board(250mm2X0.8mm)

2SD1624

■ Electrical Characteristics Ta = 25°C

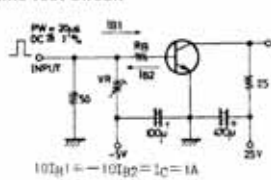
Parameter	Symbol	Testconditons	Min	Typ	Max	Unit
Collector cutoff current	ICBO	V _{CB} = 40 V, I _E =0			1	μA
Emitter cutoff current	IEBO	V _{EB} = 4 V, I _C =0			1	μA
DC current gain	hFE	V _{CE} = 2 V, I _C = 100 mA	100		560	
Gain bandwidth product	f _T	V _{CE} = 10 V, I _C = 50 mA		150		MHz
Output capacitance	C _{ob}	V _{CB} = 10 V, f = 1.0MHz		25		pF
Collector-emitter saturation voltage	V _{CE(sat)}	I _C = 2 A, I _B = 100 mA		0.19	0.5	V
Base-emitter saturation voltage	V _{BE(sat)}	I _C = 2 A, I _B = 100 mA			1.2	V
Collector-base breakdown voltage	V _{(BR)CBO}	I _C = 10μA, I _E = 0	60			V
Collector-emitter breakdown voltage	V _{(BR)CEO}	I _C = 1mA, R _{BE} = ∞	50			V
Emitter-base breakdown voltage	V _{(BR)EBO}	I _E = 10μA, I _C = 0	6			V
Turn-on time	ton	Switching Time Test Circuit 	70		ns	
Storage time	tstg		650		ns	
Turn-off time	tf		35		ns	

■ hFE Classification

Marking	DG			
Rank	R	S	T	U
hFE	100~200	140~280	200~400	280~560