

70MSPS 3-Channel AFE with Sensor Timing Generation and LVDS/CMOS Data Output

DESCRIPTION

The WM8232 is a 16-bit analogue front end/digitiser IC which processes and digitises the analogue output signals from CCD sensors or Contact Image Sensors (CIS) at pixel sample rates of up to 35MSPS.

The device has three analogue signal processing channels each of which contains Reset Level Clamping, Correlated Double Sampling (also Sample and Hold), Programmable Gain, Automatic Gain Control (AGC) and Offset adjust functions.

The output from each of these channels is time multiplexed, in pairs, into three high-speed 16-bit Analogue to Digital Converters. The digital data is available in a variety of output formats via the flexible data port.

The WM8232 has a user selectable LVDS or CMOS output architecture.

An internal 8-bit DAC is supplied for internal reference level generation. This may be used during CDS to reference CIS signals or during Clamping to clamp CCD signals. An external reference level may also be supplied. ADC references are generated internally, ensuring optimum performance from the device.

A programmable automatic Black Level Calibration function is available to adjust the DC offset of the output data.

The WM8232 features a sensor timing clock generator for both CCD and CIS sensors. The clock generator can accept a slow or fast reference clock input and also has a flexible timing adjustment function for output timing clocks to allow use of many different sensors.

FEATURES

- 70MSPS conversion rate
- 16 bit ADC resolution
- Current consumption – 230mA
- 3.3V single supply operation
- Sample and hold /correlated double sampling
- Programmable offset adjust (8-bit resolution)
- Flexible clamp timing
- Pixel clamp / line clamp mode
- Programmable clamp voltage
- Programmable CIS/CCD timing generator
- Internally generated voltage references
- Compliant for Spread Spectrum Clock
- LVDS/CMOS output options
 - LVDS 5pair 490MHz 35-bit data
 - CMOS 90MHz output maximum
- Complete on chip clock generator. MCLK 5MHz to 35MHz
- Internal timing adjustment
- Automatic Gain Control
- Automatic Black Level Calibration
- 56-lead QFN package 8mm x 8mm
- Serial control interface

APPLICATIONS

- Digital Copiers
- USB2.0 compatible scanners
- Multi-function peripherals
- High-speed CCD/CIS sensor interface

BLOCK DIAGRAM

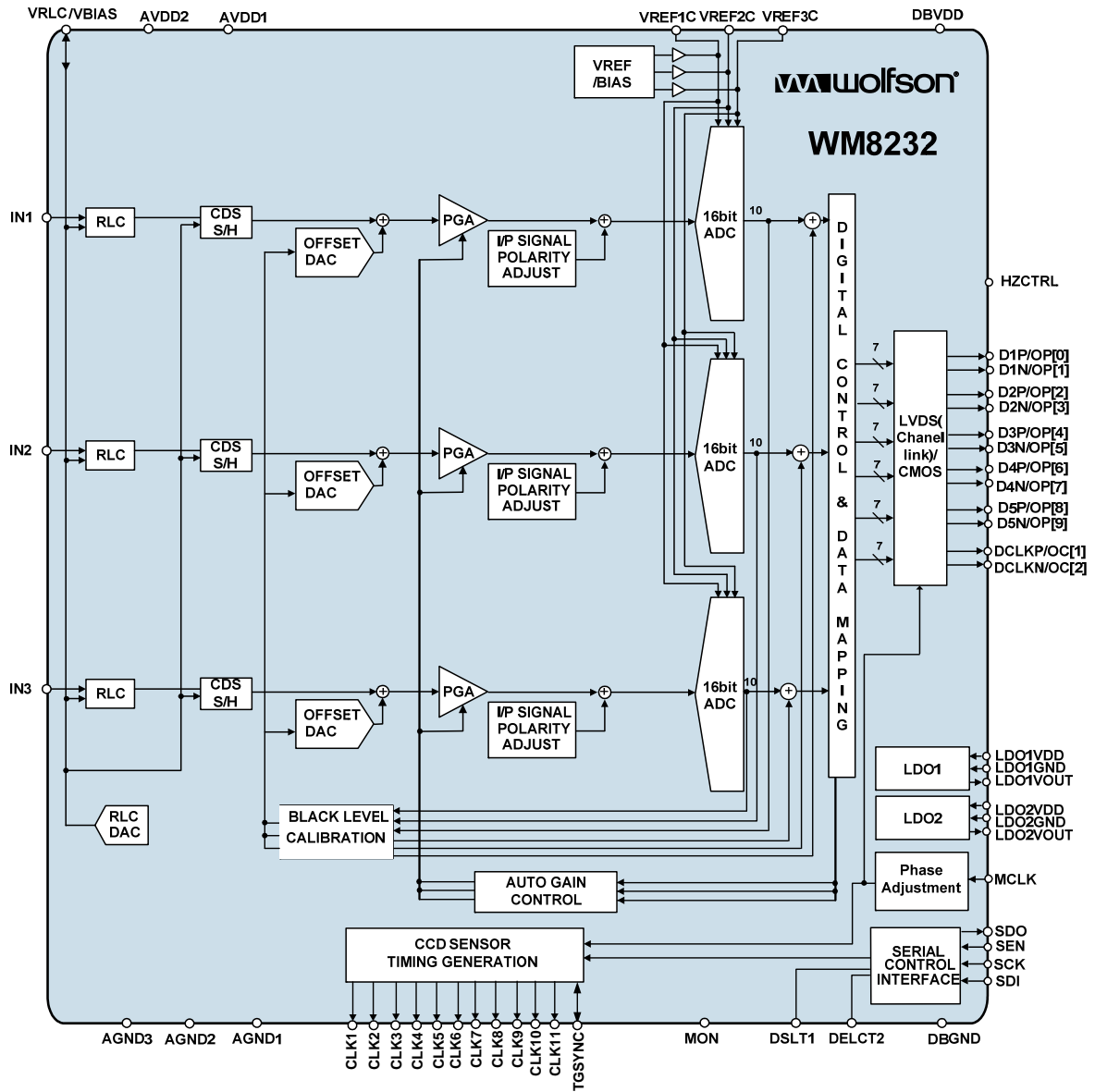
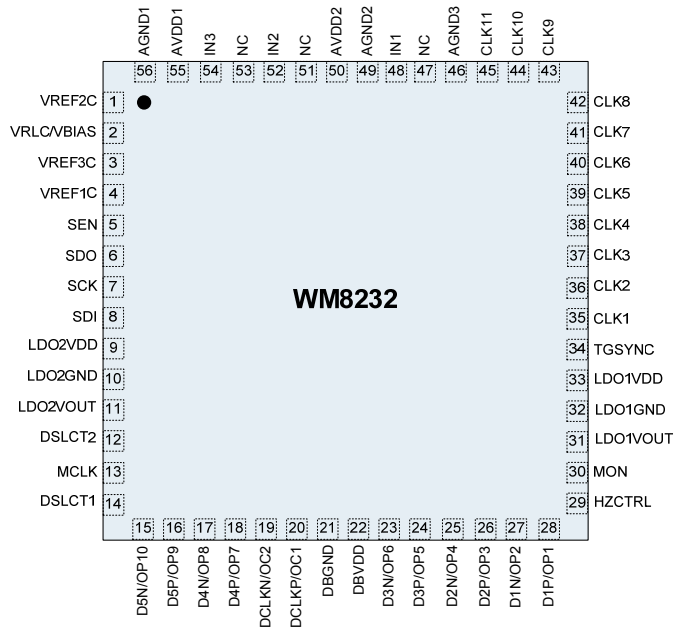

TABLE OF CONTENTS

DESCRIPTION	1
FEATURES	1
APPLICATIONS	1
BLOCK DIAGRAM	2
TABLE OF CONTENTS	3
PIN CONFIGURATION	4
ORDERING INFORMATION	4
PIN DESCRIPTION	5
ABSOLUTE MAXIMUM RATINGS	7
RECOMMENDED OPERATING CONDITIONS	7
ELECTRICAL CHARACTERISTICS	8
GENERAL CHARACTERISTICS.....	9
APPLICATION INFORMATION	11
RECOMMENDED EXTERNAL COMPONENTS	11
RECOMMENDED EXTERNAL COMPONENT VALUES	12
PACKAGE DIMENSIONS	13
IMPORTANT NOTICE	14
ADDRESS:	14
REVISION HISTORY	15

PIN CONFIGURATION



ORDERING INFORMATION

DEVICE	TEMPERATURE RANGE	PACKAGE	MOISTURE SENSITIVITY LEVEL	PEAK SOLDERING TEMPERATURE
WM8232GEFLV	-40 to 85°C	56-lead QFN (8X8x0.85mm) (Pb-free)	MSL3	260°C
WM8232GEFLRV	-40 to 85°C	56-lead QFN (8X8x0.85mm) (Pb-free, tape and reel)	MSL3	260°C

Reel quantity = 2,200

PIN DESCRIPTION

PIN	NAME	Type	DESCRIPTION
1	VREF2C	Analogue output	Mid reference voltage. This pin must be connected to AGND via a decoupling capacitor.
2	VRLC/VBIAS	Analogue I/O	Reference voltage input/output
3	VREF3C	Analogue output	Lower reference voltage. This pin must be connected to AGND via a decoupling capacitor.
4	VREF1C	Analogue output	Upper reference voltage. This pin must be connected to AGND via a decoupling capacitor.
5	SEN	Digital input	Enables the serial interface when high.
6	SDO	Digital output	Serial interface data output
7	SCK	Digital input	Serial interface clock
8	SDI	Digital input	Serial interface data input
9	LDO2VDD	Supply	Analogue supply
10	LDO2GND	Supply	Analogue ground
11	LDO2VOUT	Supply	LDO output. This pin must be connected to AGND via a decoupling capacitor.
12	DSLCT2	Analogue input	Device select 2
13	MCLK	Analogue input	Master Clock
14	DSLCT1	Analogue input	Device select 1
15	D5N/OP[9]	LVDS output	LVDS Data output 5 – Negative / CMOS output 11
16	D5P/OP[8]	LVDS output	LVDS Data output 5 – Positive / CMOS output 10
17	D4N/OP[7]	LVDS output	LVDS Data output 4 – Negative / CMOS output 9
18	D4P/OP[6]	LVDS output	LVDS Data output 4 – Positive / CMOS output 8
19	DCLKN/OC[2]	LVDS output	LVDS Clock Output – Negative/ CMOS output 7
20	DCLKP/OC[1]	LVDS output	LVDS Clock Output – Positive/ CMOS output 6
21	DBGND	Supply	Analogue ground
22	DBVDD	Supply	Analogue supply
23	D3N/OP[5]	LVDS output	LVDS Data output 3 – Negative / CMOS output 5
24	D3P/OP[4]	LVDS output	LVDS Data output 3 – Positive / CMOS output 4
25	D2N/OP[3]	LVDS output	LVDS Data output 2 – Negative / CMOS output 3
26	D2P/OP[2]	LVDS output	LVDS Data output 2 – Positive / CMOS output 2
27	D1N/OP[1]	LVDS output	LVDS Data output 1 – Negative / CMOS output 1
28	D1P/OP[0]	LVDS output	LVDS Data output 1 – Positive / CMOS output 0
29	HZCTRL	Digital input	Internal use only. Must be connected to AGND.
30	MON	Analogue output	Clock monitor
31	LDO1VOUT	Supply	LDO output. This pin must be connected to AGND via a decoupling capacitor.
32	LDO1GND	Supply	Analogue ground
33	LDO1VDD	Supply	Analogue supply
34	TGSYNC	Digital input	Sensor Timing Sync pulse from host
35	CLK1	Digital output	Sensor Timing Output 1
36	CLK2	Digital output	Sensor Timing Output 2
37	CLK3	Digital output	Sensor Timing Output 3
38	CLK4	Digital output	Sensor Timing Output 4
39	CLK5	Digital output	Sensor Timing Output 5
40	CLK6	Digital output	Sensor Timing Output 6
41	CLK7	Digital output	Sensor Timing Output 7
42	CLK8	Digital output	Sensor Timing Output 8
43	CLK9	Digital output	Sensor Timing Output 9
44	CLK10	Digital output	Sensor Timing Output 10
45	CLK11	Digital output	Sensor Timing Output 11
46	AGND3	Supply	Analogue ground
47	NC	Not connect	Not connected internally

PIN	NAME	Type	DESCRIPTION
48	IN2	Analogue input	Analogue input 2
49	AGND2	Supply	Analogue ground
50	AVDD2	Supply	Analogue supply
51	NC	Not connect	Not connected internally
52	INP4	Analogue input	Analogue input 4
53	NC	Not connect	Not connected internally
54	INP6	Analogue input	Analogue input 6
55	AVDD1	Supply	Analogue supply
56	AGND1	Supply	Analogue ground

ABSOLUTE MAXIMUM RATINGS

Absolute Maximum Ratings are stress ratings only. Permanent damage to the device may be caused by continuously operating at or beyond these limits. Device functional operating limits and guaranteed performance specifications are given under Electrical Characteristics at the test conditions specified.



ESD Sensitive Device. This device is manufactured on a CMOS process. It is therefore generically susceptible to damage from excessive static voltages. Proper ESD precautions must be taken during handling and storage of this device.

Wolfson tests its package types according to IPC/JEDEC J-STD-020B for Moisture Sensitivity to determine acceptable storage conditions prior to surface mount assembly. These levels are:

MSL1 = unlimited floor life at <30°C / 85% Relative Humidity. Not normally stored in moisture barrier bag.

MSL2 = out of bag storage for 1 year at <30°C / 60% Relative Humidity. Supplied in moisture barrier bag.

MSL3 = out of bag storage for 168 hours at <30°C / 60% Relative Humidity. Supplied in moisture barrier bag.

The Moisture Sensitivity Level for each package type is specified in Ordering Information.

CONDITION	MIN	MAX
Analogue supply voltage: AVDD1-2, LDO1VDD-LDO2VDD, DBVDD	GND - 0.3V	GND + 5V
Analogue grounds: AGND1-3, LDO1GND-LDO2VDD, DBGND	GND - 0.3V	GND + 0.3V
Analogue inputs (IN1-6)	GND - 0.3V	AVDD + 0.3V
Other Analogue pins	GND - 0.3V	AVDD + 0.3V
Digital I/O pins	GND - 0.3V	AVDD + 0.3V
Operating temperature range: T _A	-40°C	+85°C
Storage temperature prior to soldering	30°C max / 85% RH max	
Storage temperature after soldering	-65°C	+150°C

Notes:

1. GND denotes the voltage of any ground pin.
2. AGND, LDOGND and DBGND pins are intended to be operated at the same potential. Differential voltages between these pins will degrade performance.

RECOMMENDED OPERATING CONDITIONS

CONDITION	SYMBOL	MIN	TYP	MAX	UNITS
Operating temperature range	T _A	-40		85	°C
Analogue Supply voltage	AVDD1-2 LDO1VDD- LDO2VDD DBVDD	2.97	3.3	3.63	V

ELECTRICAL CHARACTERISTICS

Test Conditions

AVDD = LDOVDD = DBVDD = 3.3V , AGND = LDOGND = DBGND= 0V, T_A = 25°C, MCLK= 35MHz unless otherwise stated.

PARAMETER	SYMBOL	TEST CONDITIONS	MIN	TYP	MAX	UNIT
Overall System Specification (including 10-bit ADC, PGA, Offset and CDS functions)						
Conversion rate per channel			5		35	MSPS
Full-scale input voltage range (see Note 1)		ADCFS=0, Max Gain		0.12		Vp-p
		ADCFS=0, Min Gain		2.0		Vp-p
		ADCFS=1, Max Gain		0.18		Vp-p
		ADCFS=1, Min Gain		3.0		Vp-p
Input signal limits (see Note 2)	V _{IN}	SF_INP=0	AGND-0.3		AVDD+0.3	V
		SF_INP=1	AGND		AGND+1.2	V
Input capacitance	C _{IN}	Inputs to AGND		10		pF
Full-scale transition error		Gain = 0dB; AGAIN[4:0] = 02(hex) DGAIN[11:0] = 6AB(hex)		20		mV
Zero-scale transition error		Gain = 0dB; AGAIN[4:0] = 02(hex) DGAIN[11:0] = 6AB(hex)		20		mV
Differential non-linearity	DNL	10-bit		0.5		LSB
Integral non-linearity (pk-pk/2)	INL	10-bit		1		LSB
Channel to channel gain matching	Min Gain			5		%
	Max Gain			15		%
Output noise		Unity Gain (Unused channels grounded)		0.3		LSB rms
Channel to channel crosstalk		10-bit		+/-0.5		LSB
Programmable Gain Amplifier						
Total Resolution (Ga + Gd)	G _T			12		bits
Analogue Gain	G _a		0.6 + 0.3 * AGAIN[4:0]			V/V
Max gain, each channel (Ga)	G _a MAX	AGAIN[4:0] = 1F(hex)		9.9		V/V
Min gain, each channel (Ga)	G _a MIN	AGAIN[4:0] = 0(hex)		0.6		V/V
Digital Gain	G _d		DGAIN[11:0] / 2 ¹¹			V/V
Max gain, each channel (Gd)	G _d MAX	DGAIN[11:0] = FFF(hex)		2		V/V
Min gain, each channel (Gd)	G _d MIN	DGAIN[11:0] = 400 (hex)		0.5		V/V
Max gain, each channel (Ga + Gd)	G _T MAX	AGAIN[4:0] = 1F(hex) DGAIN[11:0] = FFF(hex)		19.8		V/V
Min gain, each channel (Ga + Gd)	G _T MIN	AGAIN[4:0] = 0(hex) DGAIN[11:0] = 400 (hex)		0.3		V/V
Analogue to Digital Converter						
Resolution				16		bits
Speed					70	MSPS

Notes:

- Full-scale input voltage** denotes the differential input signal amplitude (V_{IN}-V_R in non-CDS mode, V_{IN}-RESET level in CDS mode) that can be gained to match the ADC full-scale input range.
- Input signal limits** are the limits within which each input voltage and V_R reference must lie.

GENERAL CHARACTERISTICS

Test Conditions

AVDD = LDOVDD = DBVDD = 3.3V , AGND = LDOGND = DBGND= 0V, T_A = 25°C, MCLK= 35MHz unless otherwise stated.

PARAMETER	SYMBOL	TEST CONDITIONS	MIN	TYP	MAX	UNIT
References						
Upper reference voltage	VREF1C	ADCFS=0		2.05		V
		ADCFS=1		2.25		V
Lower reference voltage	VREF3C	ADCFS=0		1.25		V
		ADCFS=1		1.05		V
Input return bias voltage	VREF2C			1.2		V
Diff. Reference voltage (VREF1C-VREF3C)	VREF1C3C	ADCFS=0		0.8		V
		ADCFS=1		1.2		V
Output resistance VREF1C, VREF3C, VREF2C				1		Ω
VRLC/Reset-Level Clamp (RLC)						
RLC switching impedance				50		Ω
RLC short-circuit current				2		mA
RLC output resistance				2		Ω
RLC Hi-Z leakage current		VRLC = 0 to AVDD			1	μA
RLCDAC resolution				5		bits
RLCDAC step size	V _{RLCSTEP}	VRLC_TOP_SEL=0		0.09		V/step
	V _{RLCSTEP}	VRLC_TOP_SEL=1		0.048		V/step
RLCDAC output voltage at code 0(hex)	V _{RLCBOT}	VRLC_TOP_SEL=0, VRLC_VSEL[4:0]=00000		0.2		V
	V _{RLCBOT}	VRLC_TOP_SEL=1, VRLC_VSEL[4:0]=00000		0.11		V
RLCDAC output voltage at code 1F(hex)	V _{RLCTOP}	VRLC_TOP_SEL=0, VRLC_VSEL[4:0]=11111		3.0		V
	V _{RLCTOP}	VRLC_TOP_SEL=1, VRLC_VSEL[4:0]=11111		1.6		V
VRLC DNL				+/- 0.5		LSB
VRLC INL				+/- 0.5		LSB
Offset DAC, Monotonicity Guaranteed						
Resolution				8		bits
Differential non-linearity	DNL			0.1		LSB
Integral non-linearity	INL			0.75		LSB
Step size				2.04		mV/step
Output voltage		Code 00(hex)		-250		mV
		Code FF(hex)		+250		mV
DIGITAL SPECIFICATIONS						
Digital Inputs						
High level input voltage	V _{IH}		0.7 *	AVDD		V
Low level input voltage	V _{IL}				0.2 *	AVDD V
High level input current	I _{IH}				1	μA
Low level input current	I _{IL}				1	μA
Input capacitance	C _I			5		pF

Test ConditionsAVDD = LDOVDD = DBVDD = 3.3V , AGND = LDOGND = DBGND= 0V, T_A = 25°C, MCLK= 35MHz unless otherwise stated.

PARAMETER	SYMBOL	TEST CONDITIONS	MIN	TYP	MAX	UNIT
CMOS Outputs						
High level output voltage	V _{OH}	I _{OH} = 6mA	AVDD - 0.5			V
Low level output voltage	V _{OL}	I _{OL} = 1mA			0.5	V
High impedance output current	I _{OZ}				1	μA
TG Outputs						
High level output voltage	V _{OHTG}	I _{OH} = 1mA	AVDD - 0.5			V
Low level output voltage	V _{OLTG}	I _{OL} = 1mA			0.5	V
High impedance output current	I _{OZTG}	Grounded			1	μA
Digital IO Pins						
Applied high level input voltage	V _{IH}		0.7 * AVDD			V
Applied low level input voltage	V _{IL}				0.2 * AVDD	V
High level output voltage	V _{OH}	I _{OH} = 1mA	AVDD - 0.5			V
Low level output voltage	V _{OL}	I _{OL} = 1mA			0.5	V
Low level input current	I _{IL}				1	μA
High level input current	I _{IH}				1	μA
Input capacitance	C _i			5		pF
Output Impedance	R _o	I _o = 1mA		38		Ω
High impedance output current	I _{OZ}				1	μA
LVDS Outputs						
Differential load impedance	RL		90	100	110	Ω
Differential steady-state output voltage magnitude	VOD	RL=100Ω	280		450	mV
Change in the steady-state differential output voltage magnitude between opposite binary states	Δ VOD	RL=100Ω			15	mV
Steady-state common-mode output voltage	VOC(SS)	RL=100Ω		1.25		V
Peak-to-peak common-mode output	VOC(PP)			20	50	mV
Short-circuit output current	I _{OS}		-6		6	mA
High-impedance state output current	I _{OZ}		-10		10	uA
Supply Currents						
Total supply current – active		SF_INP=0, SF_VRLC=0		230		mA
		SF_INP=1, SF_VRLC=1		250		mA
Total supply current – full power down mode				1.0		mA

Notes:

- Full-scale input voltage** denotes the differential input signal amplitude (V_{IN}-VRLC in non-CDS mode, V_{IN}-RESET level in CDS mode) that can be gained to match the ADC full-scale input range.
- Input signal limits** are the limits within which each input voltage and VRLC reference must lie.

APPLICATION INFORMATION

RECOMMENDED EXTERNAL COMPONENTS

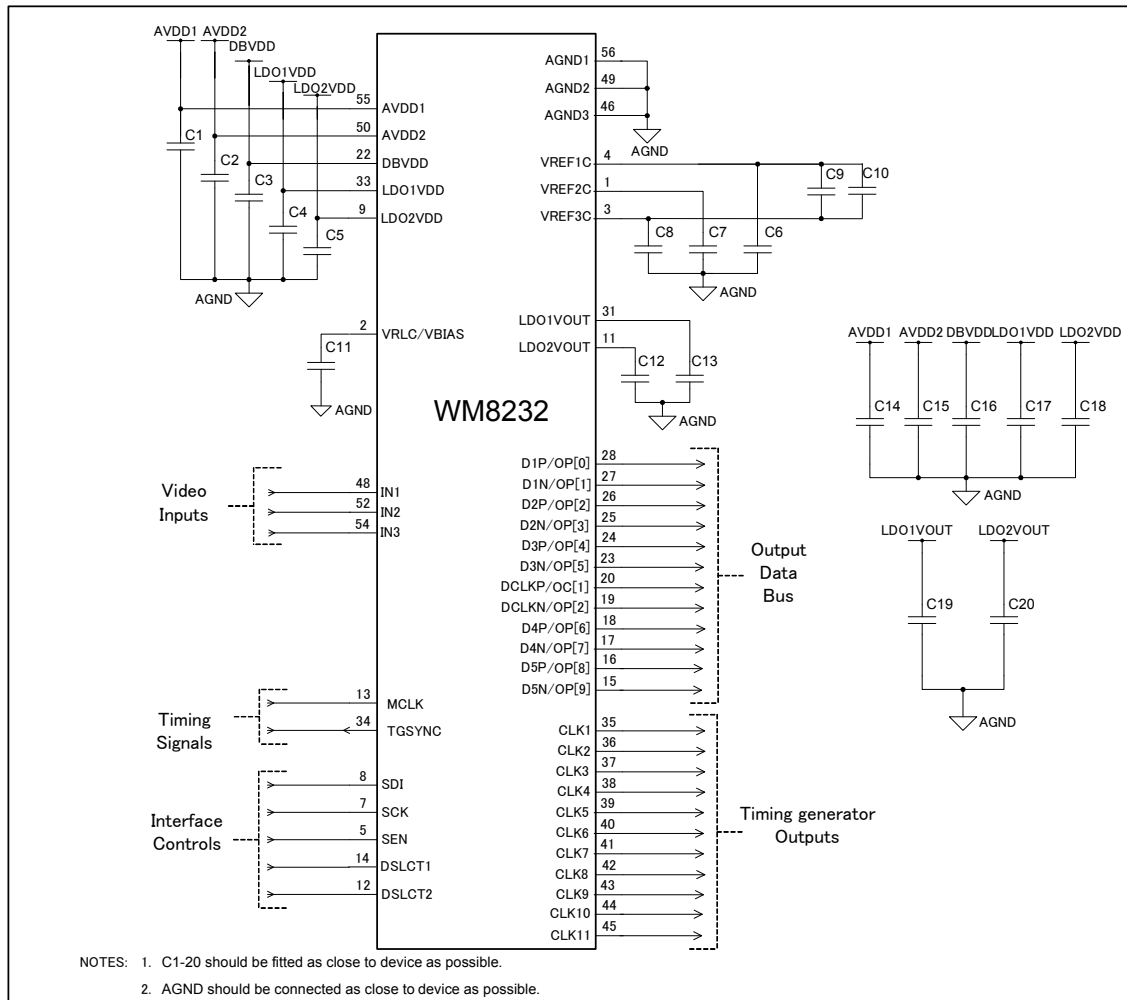

Figure 1 External Components Diagram

RECOMMENDED EXTERNAL COMPONENT VALUES

COMPONENT REFERENCE	SUGGESTED VALUE	DESCRIPTION
C1	0.1uF	De-coupling for AVDD1
C2	0.1uF	De-coupling for AVDD2
C3	0.1uF	De-coupling for DBVDD
C4	0.1uF	De-coupling for LDO1VDD
C5	0.1uF	De-coupling for LDO2VDD
C6	0.1uF	De-coupling for VREF1C
C7	0.1uF	De-coupling for VREF2C
C8	0.1uF	De-coupling for VREF3C
C9	0.01uF	High frequency decoupling between VREF1C and VREF3C
C10	10uF	Low frequency decoupling between VREF1C and VREF3C
C11	1uF	De-coupling for VRLC/VBIAS
C12	1uF	De-coupling for LDO1VOUT
C13	1uF	De-coupling for LDO2VOUT
C14	10uF	Reservoir capacitor for AVDD1
C15	10uF	Reservoir capacitor for AVDD2
C16	10uF	Reservoir capacitor for DBVDD
C17	10uF	Reservoir capacitor for LDO1VDD
C18	10uF	Reservoir capacitor for LDO2VDD
C19	10uF	Reservoir capacitor for LDOOUT
C20	10uF	Reservoir capacitor for LDOOUT

Table 1 External Components Description

PACKAGE DIMENSIONS

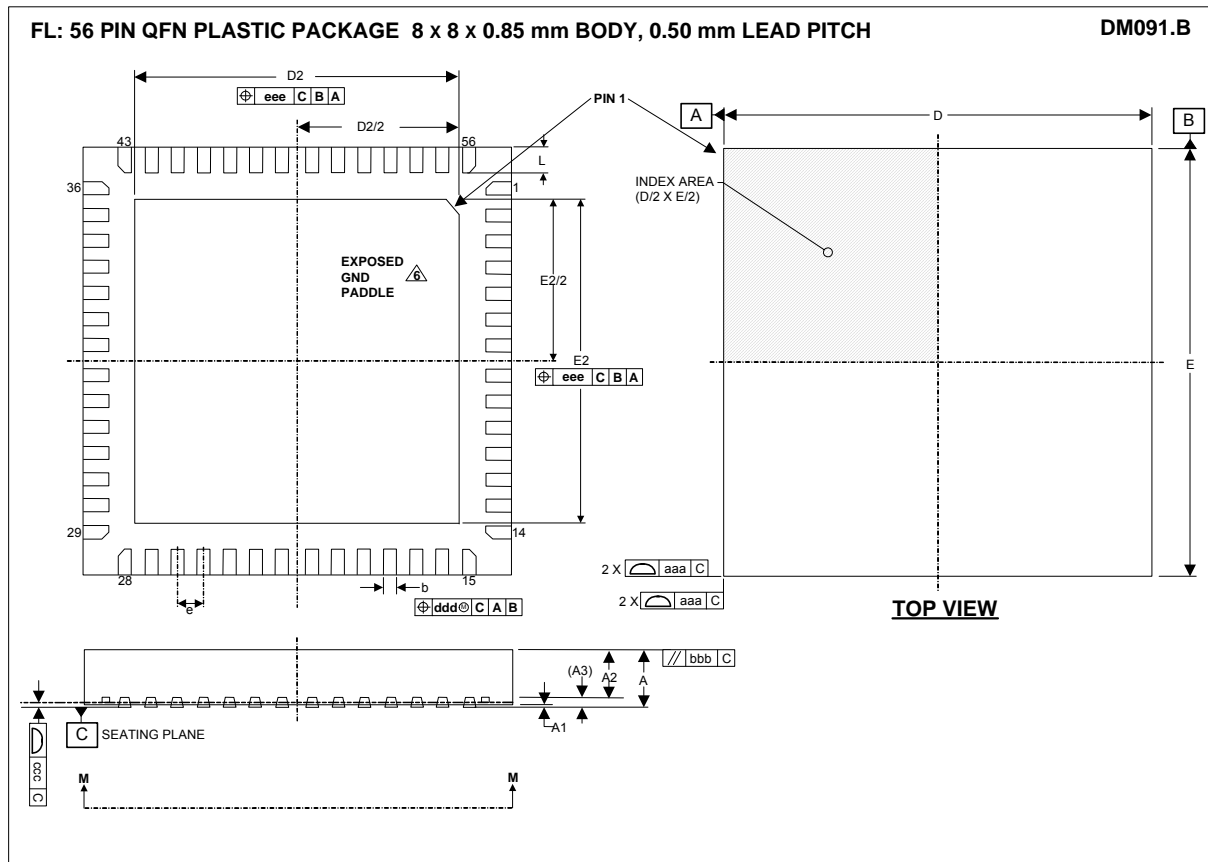

Symbols	Dimensions (mm)			NOTE
	MIN	NOM	MAX	
A	0.8	0.85	0.9	
A1	0	0.035	0.05	
A2	-	0.65	0.67	
A3		0.203 REF		
b	0.20	0.25	0.30	1
D		8.00 BSC		
D2	5.95	6.05	6.15	
E		8.00 BSC		
E2	5.95	6.05	6.15	
e		0.5 BSC		
L	0.35	0.4	0.45	
Tolerances of Form and Position				
aaa	0.10			
bbb	0.10			
ccc	0.08			
ddd	0.10			
eee	0.10			
REF	JEDEC, MO-220, VARIATION VLLD-2			

- NOTES:
1. DIMENSION b APPLIED TO METALLIZED TERMINAL AND IS MEASURED BETWEEN 0.15 mm AND 0.30 mm FROM TERMINAL TIP.
 2. ALL DIMENSIONS ARE IN MILLIMETRES
 3. THE TERMINAL #1 IDENTIFIER AND TERMINAL NUMBERING CONVENTION SHALL CONFORM TO JESD 95-1 SPP-002.
 4. COPLANARITY APPLIES TO THE EXPOSED HEAT SINK SLUG AS WELL AS THE TERMINALS.
 5. THIS DRAWING IS SUBJECT TO CHANGE WITHOUT NOTICE.
 6. REFER TO APPLICATIONS NOTE WAN_0118 FOR FURTHER INFORMATION.

IMPORTANT NOTICE

Wolfson Microelectronics plc ("Wolfson") products and services are sold subject to Wolfson's terms and conditions of sale, delivery and payment supplied at the time of order acknowledgement.

Wolfson warrants performance of its products to the specifications in effect at the date of shipment. Wolfson reserves the right to make changes to its products and specifications or to discontinue any product or service without notice. Customers should therefore obtain the latest version of relevant information from Wolfson to verify that the information is current.

Testing and other quality control techniques are utilised to the extent Wolfson deems necessary to support its warranty. Specific testing of all parameters of each device is not necessarily performed unless required by law or regulation.

In order to minimise risks associated with customer applications, the customer must use adequate design and operating safeguards to minimise inherent or procedural hazards. Wolfson is not liable for applications assistance or customer product design. The customer is solely responsible for its selection and use of Wolfson products. Wolfson is not liable for such selection or use nor for use of any circuitry other than circuitry entirely embodied in a Wolfson product.

Wolfson's products are not intended for use in life support systems, appliances, nuclear systems or systems where malfunction can reasonably be expected to result in personal injury, death or severe property or environmental damage. Any use of products by the customer for such purposes is at the customer's own risk.

Wolfson does not grant any licence (express or implied) under any patent right, copyright, mask work right or other intellectual property right of Wolfson covering or relating to any combination, machine, or process in which its products or services might be or are used. Any provision or publication of any third party's products or services does not constitute Wolfson's approval, licence, warranty or endorsement thereof. Any third party trade marks contained in this document belong to the respective third party owner.

Reproduction of information from Wolfson datasheets is permissible only if reproduction is without alteration and is accompanied by all associated copyright, proprietary and other notices (including this notice) and conditions. Wolfson is not liable for any unauthorised alteration of such information or for any reliance placed thereon.

Any representations made, warranties given, and/or liabilities accepted by any person which differ from those contained in this datasheet or in Wolfson's standard terms and conditions of sale, delivery and payment are made, given and/or accepted at that person's own risk. Wolfson is not liable for any such representations, warranties or liabilities or for any reliance placed thereon by any person.

ADDRESS:

Wolfson Microelectronics plc
Westfield House
26 Westfield Road
Edinburgh
EH11 2QB

Tel :: +44 (0)131 272 7000

Fax :: +44 (0)131 272 7001

Email :: sales@wolfsonmicro.com

REVISION HISTORY

DATE	REV	ORIGINATOR	CHANGES
16/11/10	1.0	NB	First Release
09/02/12	3.0	JMacD	Current consumption updated to 230mA DAC description updated from 4-bit to 8-bit Temperature range updated to -40 Updated ADCFS characteristics Updated RLC DAC resolution Updated parameter name and register name for RLC DAC Added test condition for TG output Updated Supply currents
29/02/12	3.0	JMacD	Recommended External Component Values – C9 value updated to 0.01uF