

PRODUCTION QUANTITIES AVAILABLE FOR IMMEDIATE DELIVERY

High performance

SUHL Integrated Circuits . . . The finest TTL saturated logic in the industry.

Type Nos.	Function
SG-40, SG-41, SG-42, SG-43	Dual 4-Input NAND/NOR Gate
SG-50, SG-51, SG-52, SG-53	Expandable Quad 2-Input OR Gate
SG-60, SG-61, SG-62, SG-63	Single 8-Input NAND/NOR Gate
SG-70, SG-71, SG-72, SG-73	Expandable Dual Output, Dual 2-Input OR Gate
SG-80, SG-81, SG-82, SG-83	Dual Pulse Shaper/Delay-AND Gate
SG-90, SG-91, SG-92, SG-93	Exclusive-OR with Complement
SG-100, SG-101, SG-102, SG-103	Expandable Triple 3-Input OR Gate
SG-110, SG-111, SG-112, SG-113	Expandable Dual 4-Input OR Gate
SG-120, SG-121, SG-122, SG-123	Expandable Single 8-Input NAND/NOR Gate
SG-130, SG-131, SG-132, SG-133	Dual 4-Input Line Driver
SG-140, SG-141, SG-142, SG-143	Quad 2-Input NAND/NOR Gate
SG-150, SG-151, SG-152, SG-153	Quad 2-Input OR Expander
SG-160, SG-161, SG-162, SG-163	Triple 2-Input Bus Driver
SG-170, SG-171, SG-172, SG-173	Dual 4-Input OR Expander
SG-180, SG-181, SG-182, SG-183	Dual 4-Input AND Expander
SG-190, SG-191, SG-192, SG-193	Triple 3-Input NAND/NOR Gate
SG-280, SG-281, SG-282, SG-283	Dual 4-Input AND/OR Gate
SG-330, 331, 332, 333	Quad 2-Input NAND/NOR Gate
SG-351, SG-353	Quad 2-Input Lamp Driver
SG-370, 371, 372, 373	Hex 1-Input Inverter
SF-30, SF-31, SF-32, SF-33	Single Phase SRT Flip-Flop
SF-50, SF-51, SF-52, SF-53	J-K Flip-Flop (AND Inputs)
SF-60, SF-61, SF-62, SF-63	J-K Flip-Flops (OR Inputs)
SF-80, SF-81, SF-82, SF-83	Dual D Flip-Flop
SF-100, SF-101, SF-102, SF-103	Dual 35MHz Flip-Flop (Separate Clock)
SF-110, SF-111, SF-112, SF-113	Dual 35MHz J-K Flip-Flop (Common Clock)
SG-200, SG-201, SG-202, SG-203	Expandable Single 8-Input NAND/NOR Gate
SG-210, SG-211, SG-212, SG-213	Expandable Dual 4-Input OR Gate
SG-220, SG-221, SG-222, SG-223	Quad 2-Input NAND/NOR Gate
SG-230, SG-231, SG-232, SG-233	Quad 2-Input OR Expander
SG-240, SG-241, SG-242, SG-243	Dual 4-Input NAND/NOR Gate
SG-250, SG-251, SG-252, SG-253	Expandable Quad 2-Input OR Gate
SG-260, SG-261, SG-262, SG-263	Single 8-Input NAND/NOR Gate
SG-270, SG-271, SG-272, SG-273	Dual 4-Input OR Expander
SG-290, SG-291, SG-292, SG-293	Dual 2 & 3 Input AND/OR Expander
SG-300, SG-301, SG-302, SG-303	Expandable Triple 3-Input OR Gate
SG-310, SG-311, SG-312, SG-313	Expandable Dual Output Dual 2-Input OR Gate
SG-320, SG-321, SG-322, SG-323	Triple 3-Input NAND/NOR Gate
SG-340, 341, 342, 343	Quad 2-Input NAND/NOR Gate
SG-380, 381, 382, 383	Hex 1-Input Inverter
SF-91, SF-93	Dual D Flip-Flop
SF-120, SF-121, SF-122, SF-123	Dual 50MHz J-K Flip-Flop (Separate Clock)

Type Nos.	Function
SF-130, SF-131, SF-132, SF-133	Dual 50MHz J-K Flip-Flop (Common Clock)
SF-200, SF-201, SF-202, SF-203	50MHz J-K Flip-Flop (AND Inputs)
SF-210, SF-211, SF-212, SF-213	50MHz J-K Flip-Flop (OR Inputs)

Digital Functional Arrays . . . High-density, low-geometry multi-function circuits.

Type Nos.	Function
SM10 Series	Full Adder
SM20 Series	Dependent Carry Fast Adder
SM30 Series	Independent Carry Fast Adder
SM40 Series	Carry Decoder
SM60 Series	4-Bit Storage Register
SM70 Series	Bus Transfer Output 4-Bit Storage Register
SM80 Series	Cascade Pullup Output 16-Bit Scratch Pad Memory
SM90/92 Series	Decade Frequency Divider
SM91-93 Series	4-Bit Shift Register
SM110	Parity Generator/Checker
SM120 Series	Comparator
SM130 Series	Programmable Binary Divider
SM140 Series	Programmable Decade Divider
SM150 Series	Binary Counter
SM160 Series	Decade Counter
SM170 Series	Binary Up/Down Counter
SM180 Series	Decade Up/Down Counter
SM190 Series	BCD to 7-Segment Translator
SM200 Series	Dual 4-Bit Multiplexer
SM210 Series	Demultiplexer
SG7400N	Quad 2-Input NAND/NOR Gate
SG7402N	Quad 2-Input Positive
SG7410N	Triple 3-Input NAND/NOR Gate
SG7420N	Dual 4-Input NAND/NOR Gate
SG7450N	Expandable Dual 2 Wide 2-Input AND-OR-INVERT Gate
SG7454N	4 Wide 2-Input AND-OR INVERT Gate
SG7460N	Dual 4-Input OR Expander
SF7472N	J-K Master-Slave Flip-Flop
SF7473N	Dual J-K Master Slave Flip-Flop w/Clear
SF7474N	Dual "D" Flip-Flop
SM7444N	BCD to Decimal Decoder
SM7491N	8-Bit Shift Register
SA20, SA21	Wide-band Video Amplifiers

GENERAL CHARACTERISTICS SUHL I INTEGRATED CIRCUITS

Absolute Maximum Ratings

	Military	Industrial	Unit
Supply Voltage	8	7	Vdc.
Operating Temperature	-55° to +125°	0° to +75°	°C
Storage Temperature	-65° to +200°	-65° to +200°	°C

Electrical Characteristics at 25° C, Vcc=5V

Input Characteristics	Min.	Typ.	Max.	Unit
Logic 1 Voltage	1.7		5.5	Volts
Logic 1 Current			100	μA
Logic 0 Voltage			1.2	Volts
Logic 0 Current		1.0		mA
Capacitance		2.0		pf
Positive Noise Immunity ¹	1.0			Volts
Negative Noise Immunity	1.0			Volts
Frequency		20		MHz
Output Characteristics	Min.	Typ.	Max.	Unit
Logic 1 Voltage ²	3.0	3.5	3.8	Volts
Logic 0 Voltage		0.26	0.45	Volts
Short Circuit Output Current	10		45.0	mA
Propagation Delay Time/Gate (varies with element designed to be used up to 20 MHz)		10	20	ns
Fan-Out	varies with elements designed for fan-outs of 6 to 30			

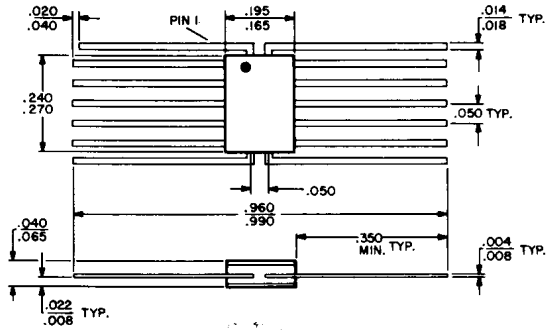

14-lead, metal lid, ceramic flat pack (TO-85)

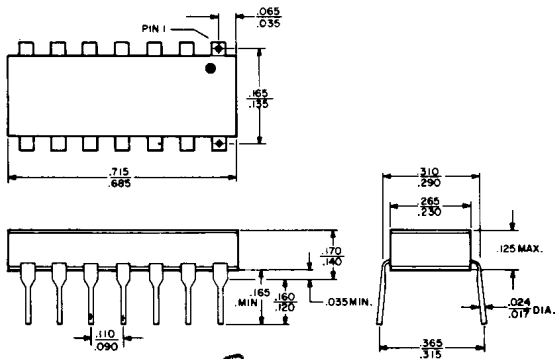

14-lead, metal lid, ceramic dual-in-line (TO-116)

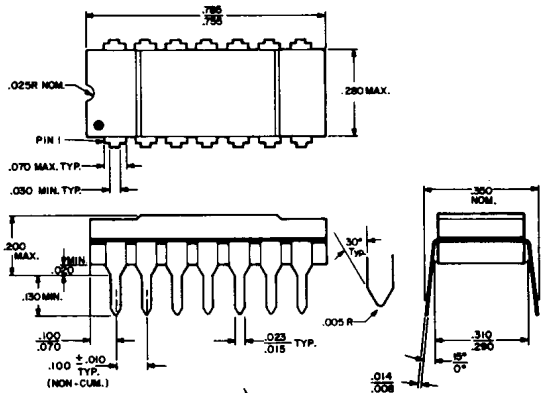

14-lead, CERDIP dual-in-line (TO-116)

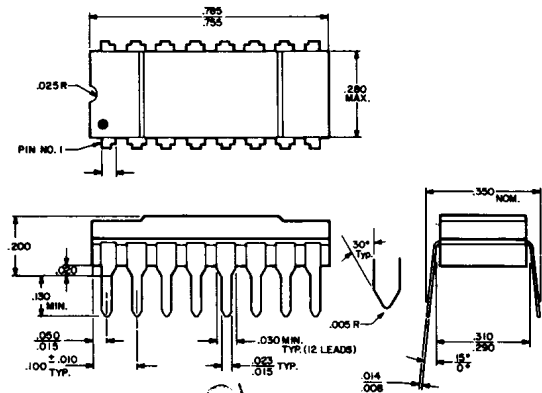

16-lead, CERDIP dual-in-line

GENERAL CHARACTERISTICS SUHL II INTEGRATED CIRCUITS

Absolute Maximum Ratings

	Military	Industrial	Unit
Supply Voltage	8	7	Vdc.
Operating Temperature	-55° to +125°	0° to +75°	°C
Storage Temperature	-65° to +200°	-65° to +200°	°C

Electrical Characteristics at 25° C, Vcc=5V

Input Characteristics	Min.	Typ.	Max.	Unit
Logic 1 Voltage	1.7		5.5	Volts
Logic 1 Current			100	μA
Logic 0 Voltage			1.1	Volts
Logic 0 Current		1.7		mA
Capacitance		1.5		pf
Positive Noise Immunity ¹	1.0			Volts
Negative Noise Immunity	1.5			Volts
Output Characteristics	Min.	Typ.	Max.	Unit
Logic 1 Voltage ²	3.0	3.5	3.8	Volts
Logic 0 Voltage		0.26	0.45	Volts
Short Circuit Output Current ³			65.0	mA
Propagation Delay Time/Gate (varies with element designed to be used up to 40 mc)		6	10	ns
Fan-Out	varies with elements designed for fan-outs of 5 to 12			

1. Noise immunity is that voltage superimposed on the input which will not propagate beyond the following stage. ■ 2. With max Vce (sat) on input. ■ 3. One second pulse.

TYPICAL CIRCUITS SUHL I

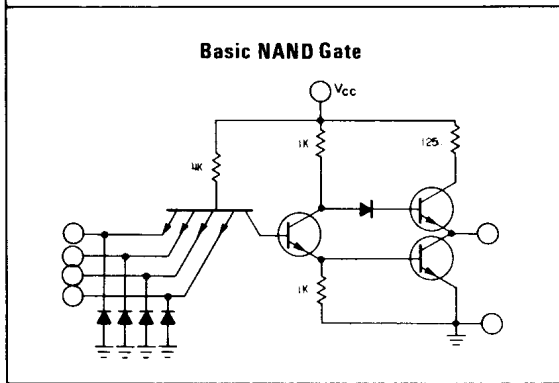
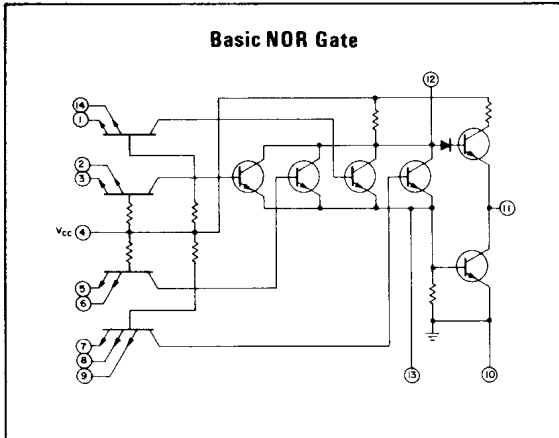

TYPICAL CIRCUITS SUHL II

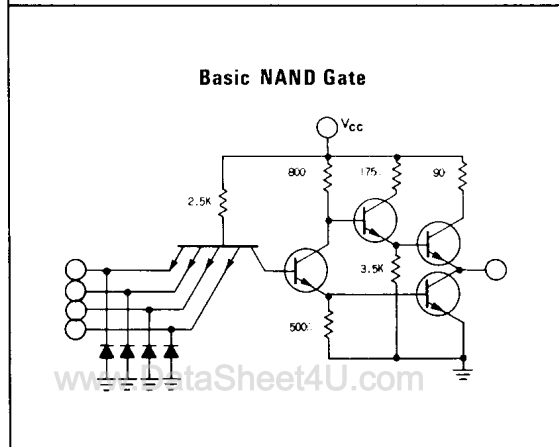
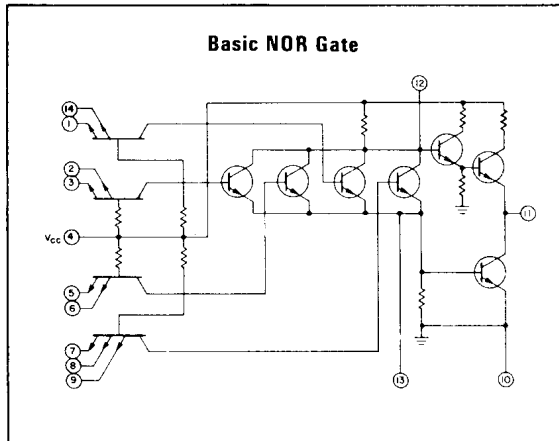

NAND/NOR GATES SUHL I

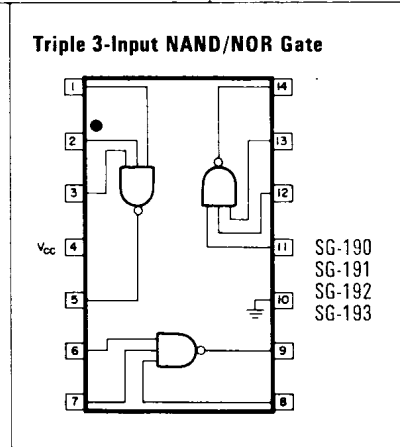
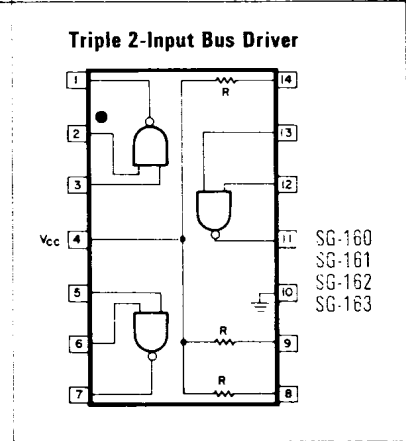
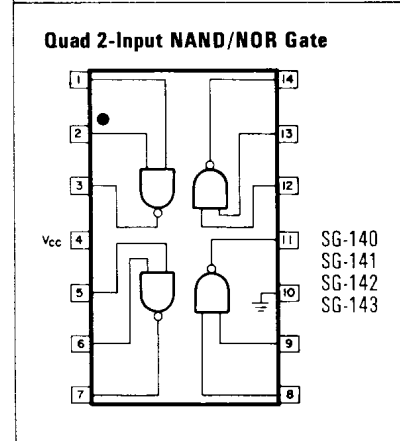
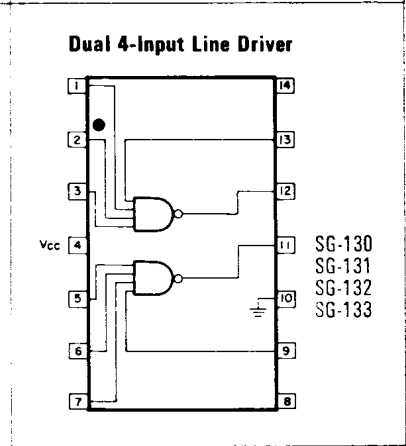
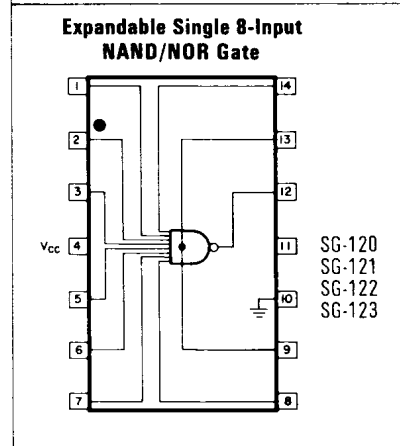
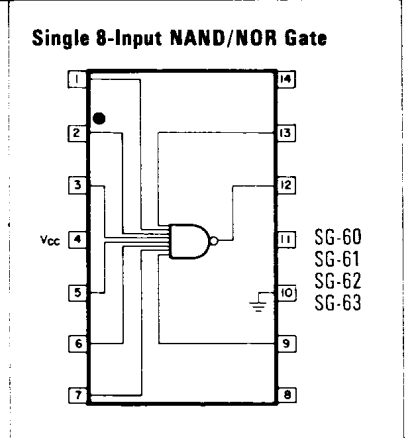
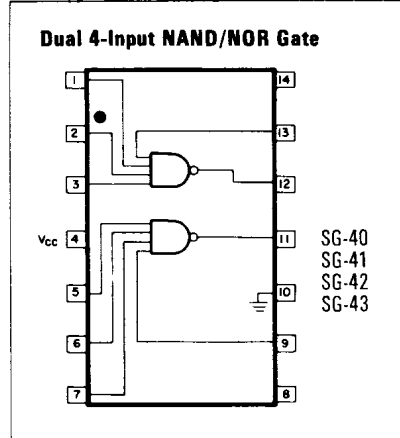

NAND/NOR GATES SUHL II

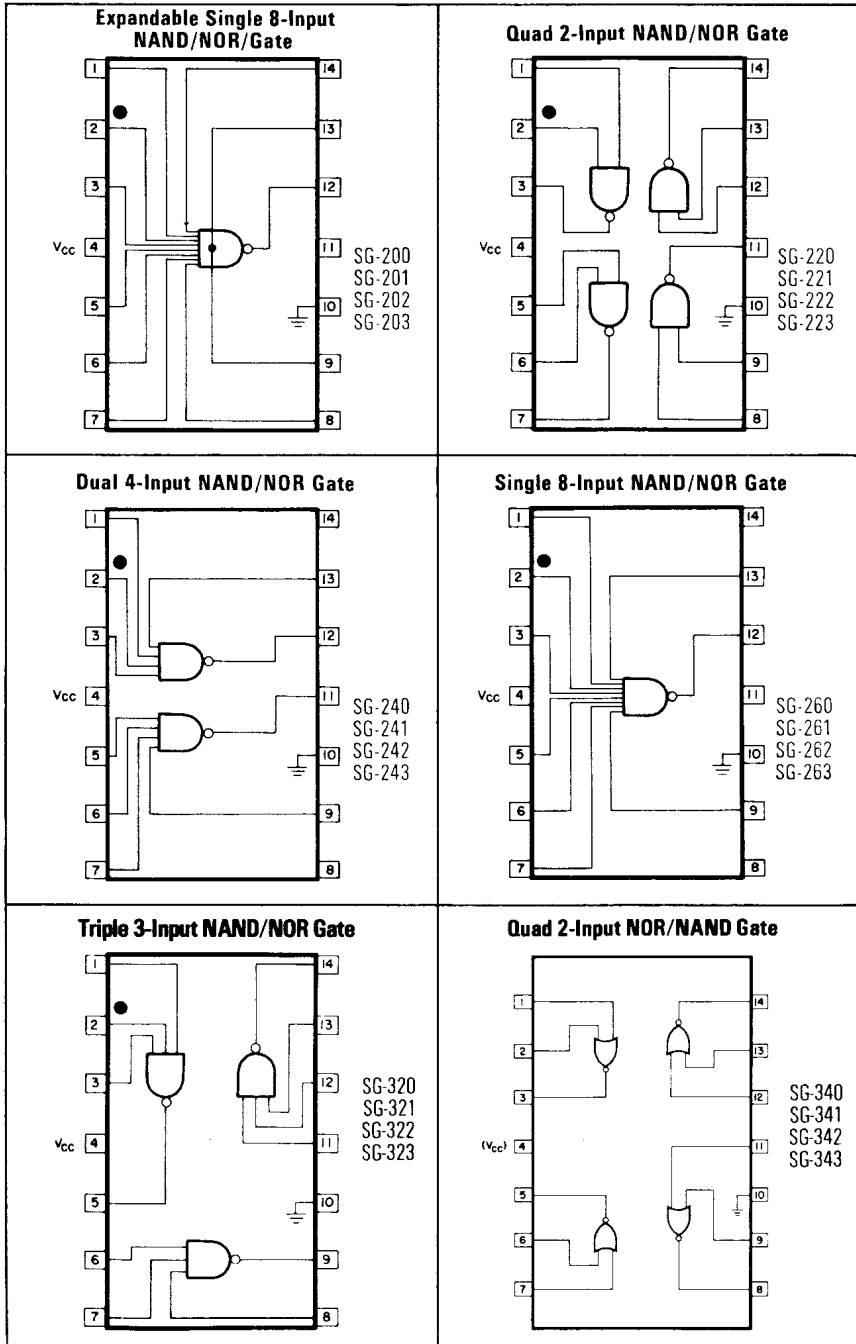

NAND/NOR GATES SUHL I

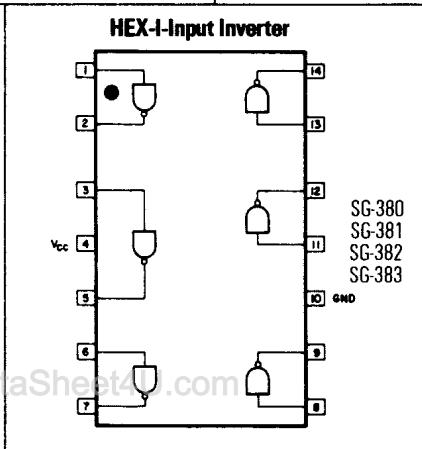
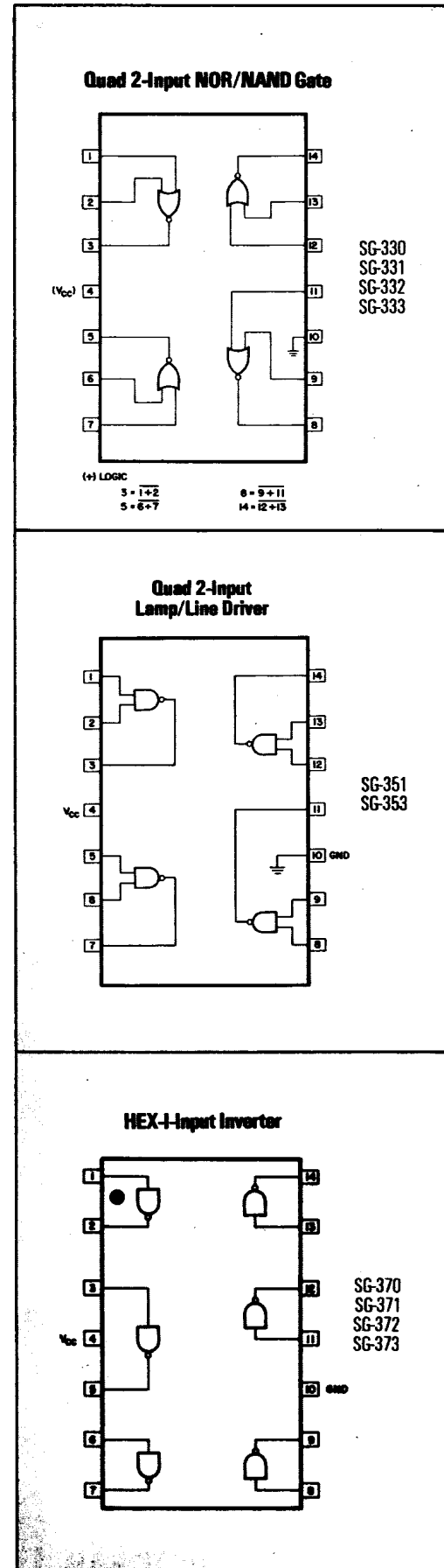

AND-NOR GATES SUHL I

AND-NOR GATES SUHL II

Expandable Quad 2-Input OR Gate

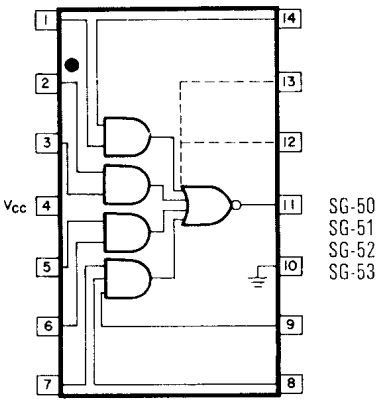

Expandable Dual 4-Input OR Gate

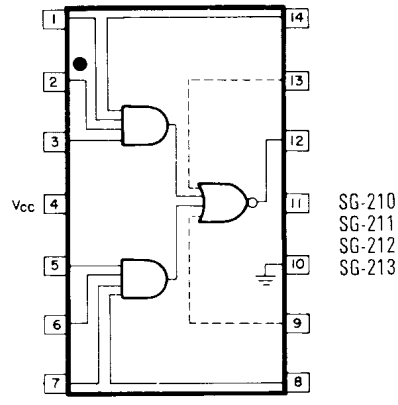

Expandable Quad 2-Input OR Gate

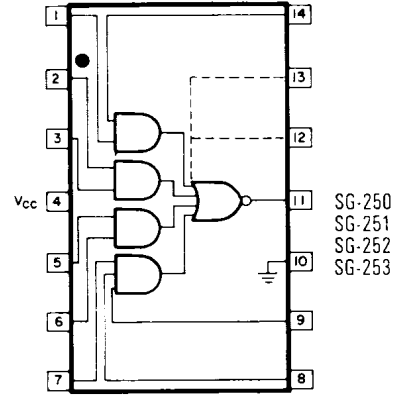

Expandable Dual Output Dual 2-Input OR Gate

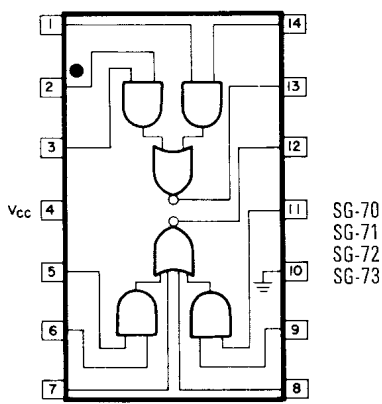

Exclusive OR with Complement

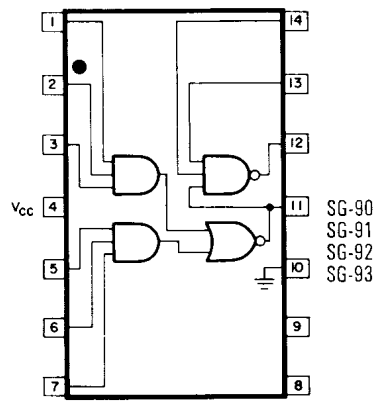

Expandable Triple 3-Input OR Gate

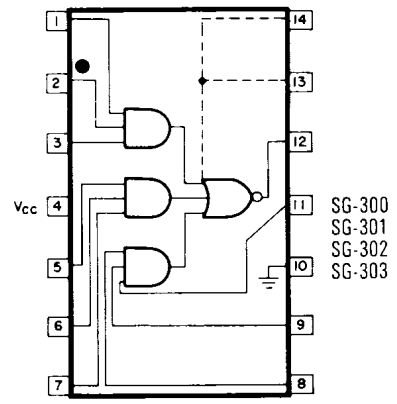

Expandable Triple 3-Input OR Gate

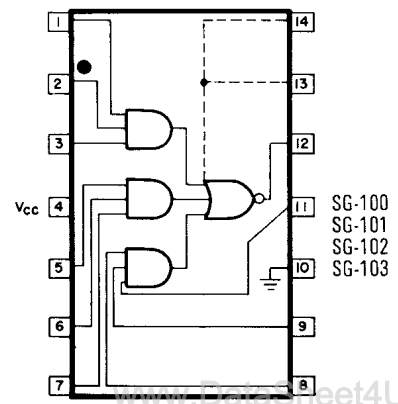

Expandable Dual 4-Input OR Gate

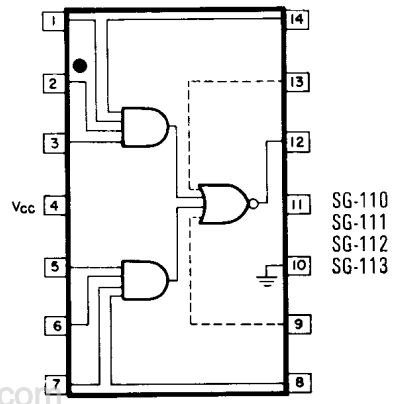

Expandable Dual Output Dual 2-Input OR Gate

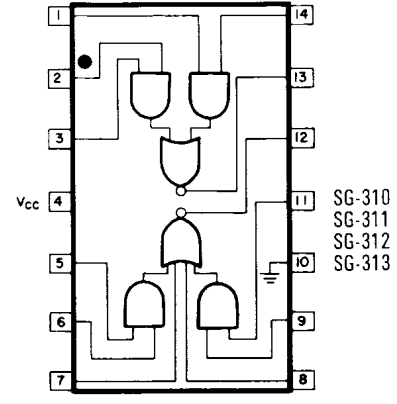

AND EXPANDERS SUHL I & SUHL II

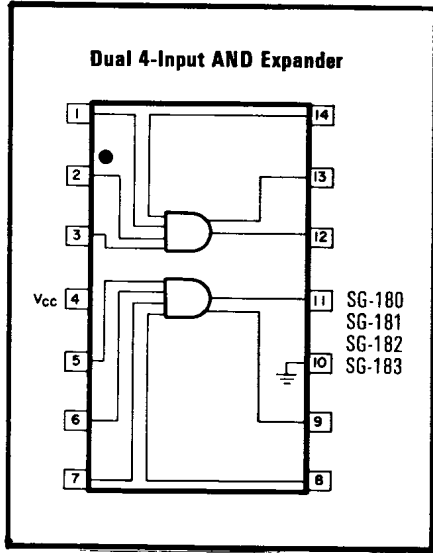

NON-INVERTING GATES SUHL I

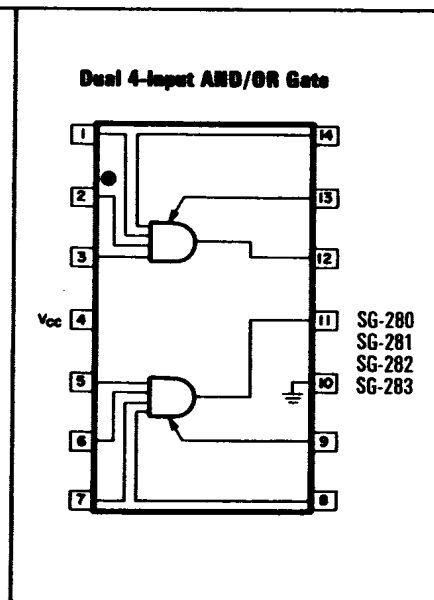
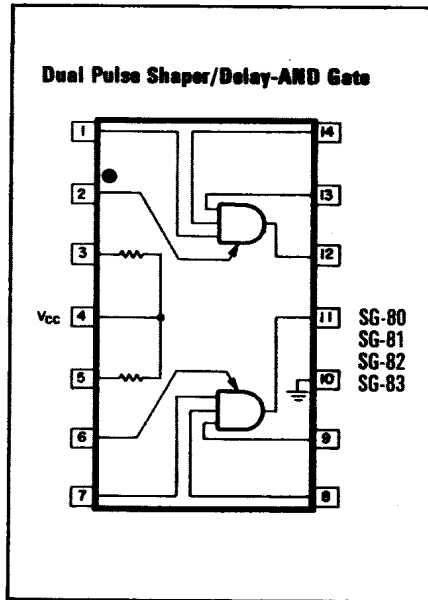

OR EXPANDERS SUHL I

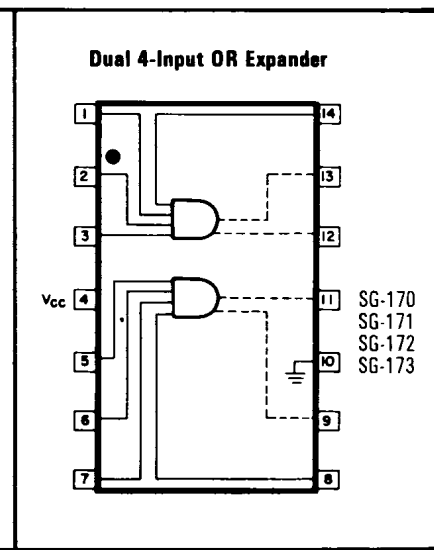
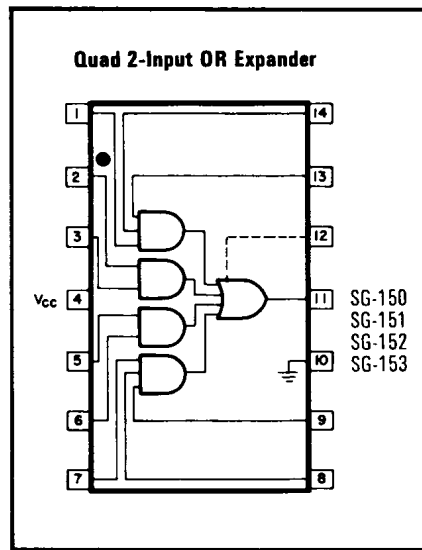
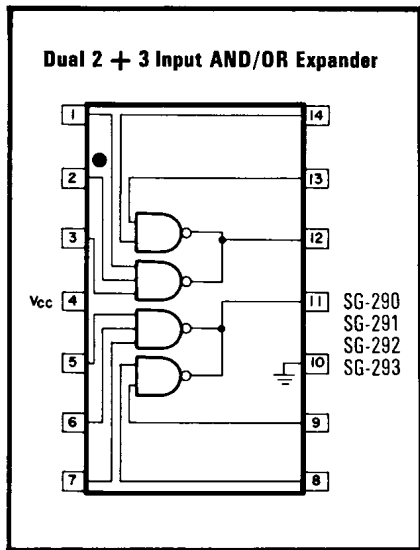

OR EXPANDERS SUHL II

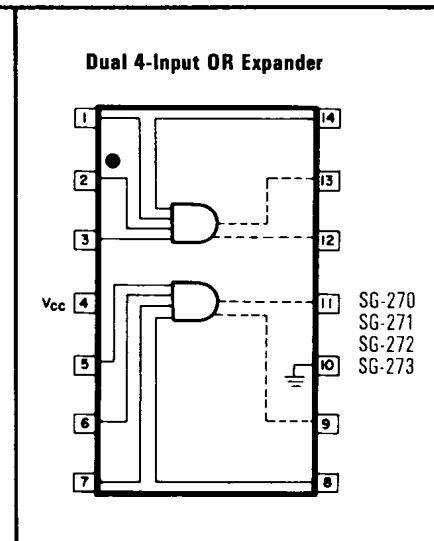
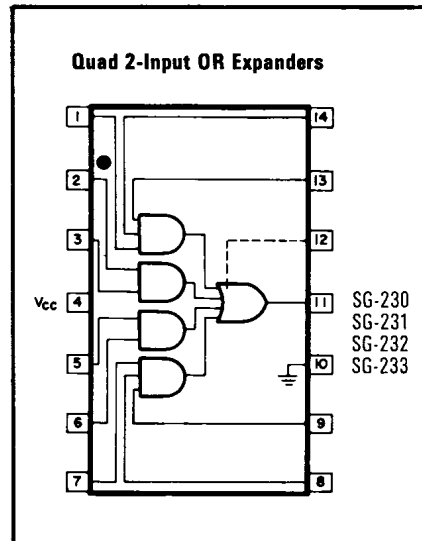

FLIP-FLOPS SUHL I

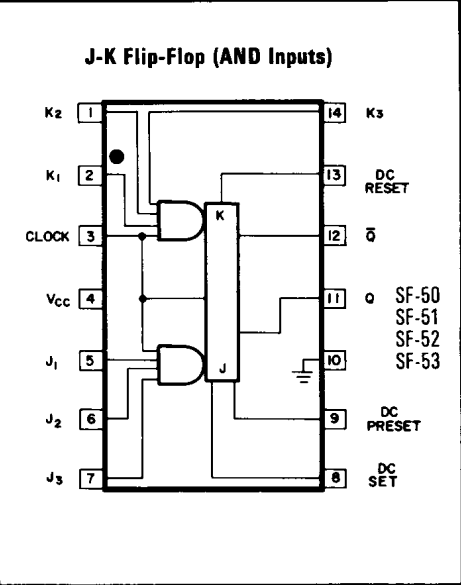
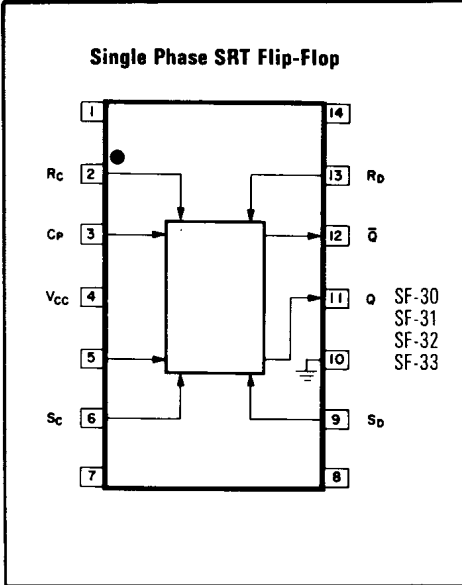

FLIP-FLOPS SUHL II

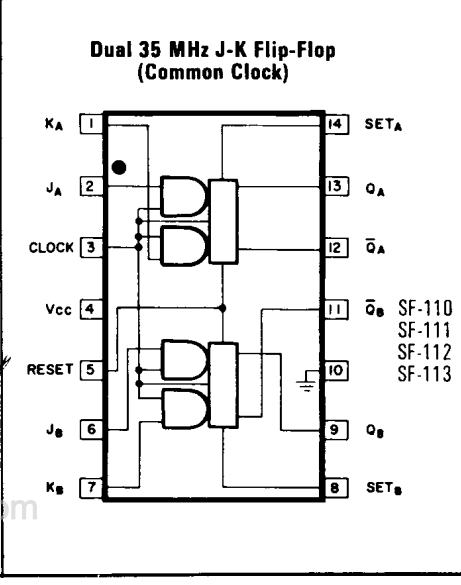
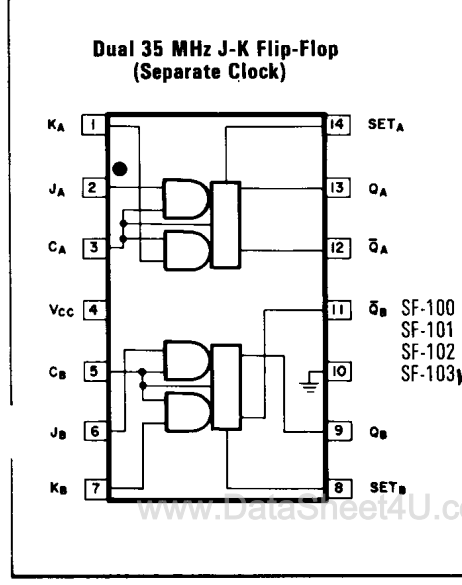
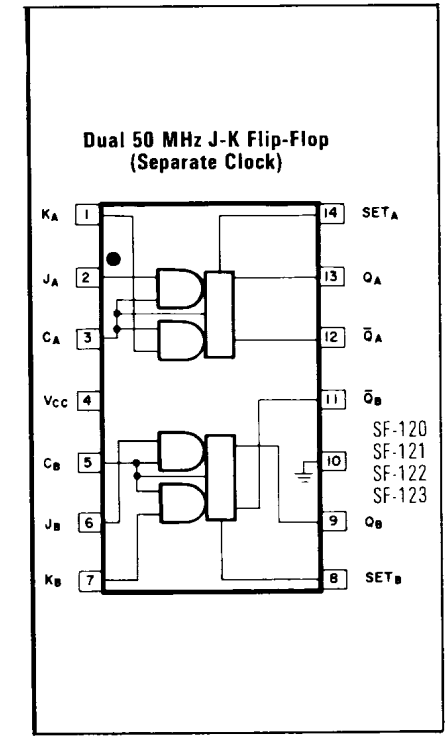
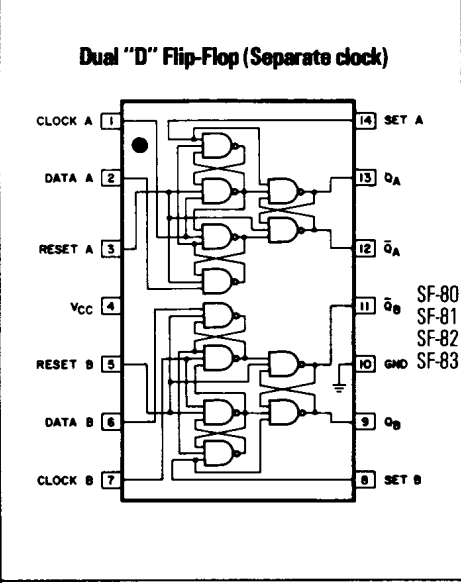
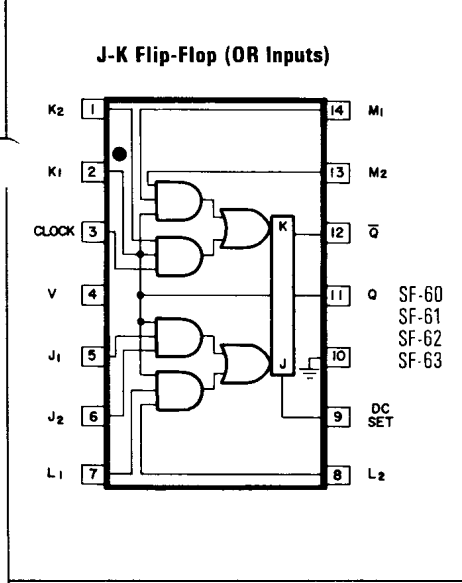
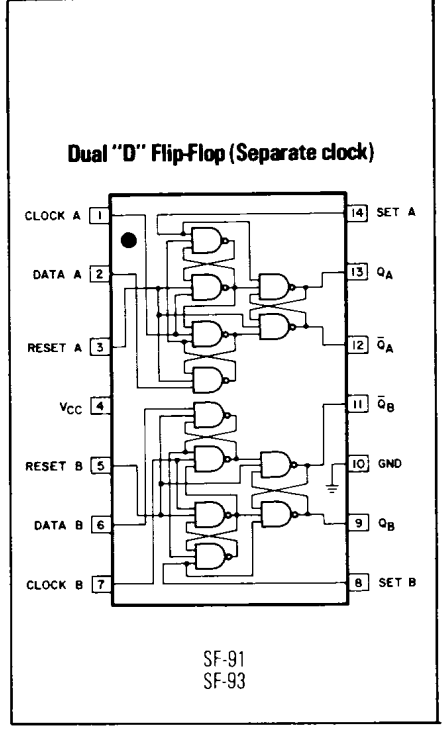

www.DataSheet4U.com

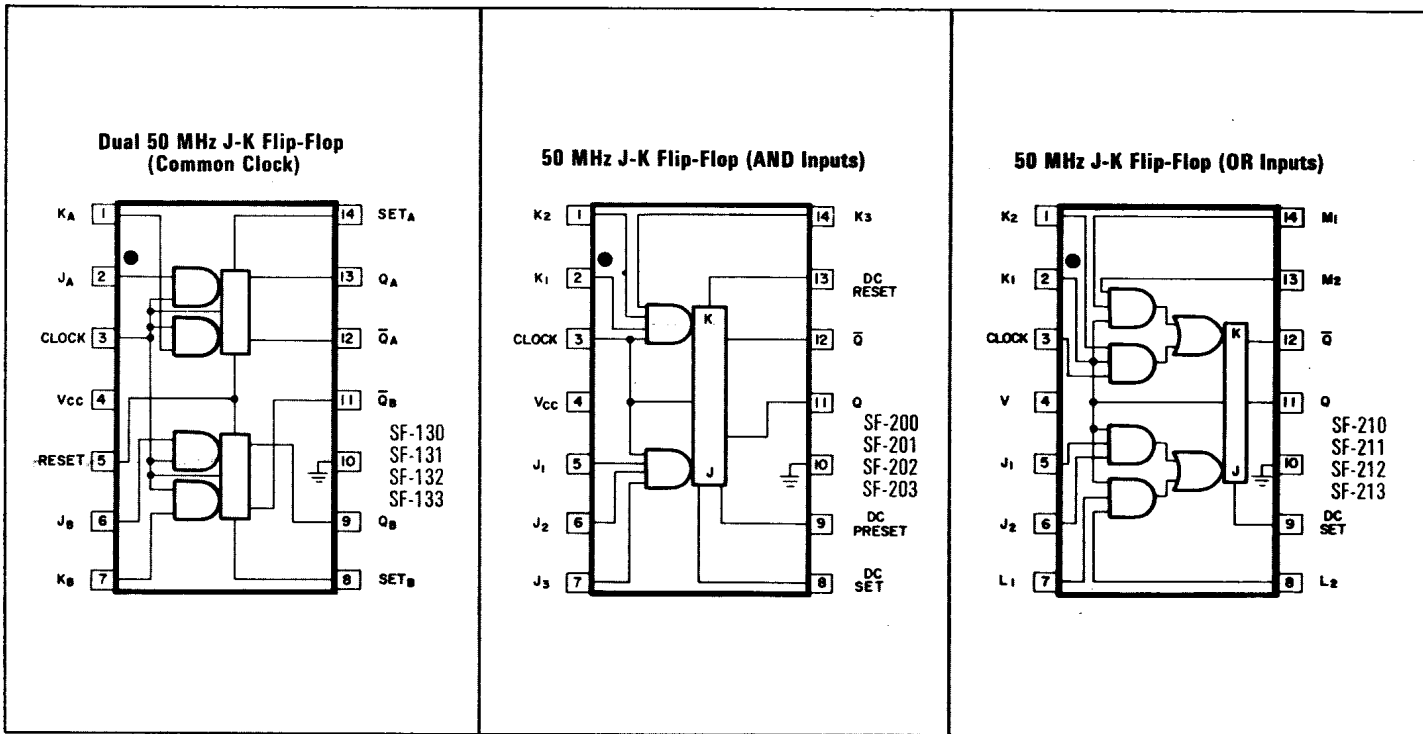

TYPICAL CIRCUIT DIAGRAMS

