



Product Specifications

26.0" WXGA Color TFT-LCD Module
Model Name: T260XW01
V.7

(*) Preliminary Specifications
() Final Specifications

Note: This Specification is subject to change without notice.



Contents

No	ITEM
	COVER
	CONTENTS
	RECORD OF REVISIONS
1	GENERAL DESCRIPTION
2	ABSOLUTE MAXIMUM RATINGS
3	ELECTRICAL SPECIFICATIONS
3-1	ELECTRICAL CHARACTERISTICS
3-2	INTERFACE CONNECTIONS
3-3	INPUT TIMING SPECIFICATIONS
3-4	COLOR INPUT DATA REFERENCE
3-5	POWER SEQUENCE
4	OPTICAL SPECIFICATIONS
5	MECHANICAL CHARACTERISTICS
6	RELIABILITY
7	INTERNATIONAL STANDARDS
7-1	SAFETY
7-2	EMC
8	Packing
9	PRECAUTIONS



Record of Revision

Version	Date	No	Old Description	New Description	Remark
V.7	Jun. 29'04	All	Preliminary Specification issued		



1. General Description

This specification applies to the 26.0 inch Color TFT-LCD Module T260XW01. This LCD module has a TFT active matrix type liquid crystal panel 1280x768 pixels, and diagonal size of 26.0 inch. This module supports 1280x768 XGA-WIDE mode (Non-interlace).

Each pixel is divided into Red, Green and Blue sub-pixels or dots which are arranged in vertical stripes. Gray scale or the brightness of the sub-pixel color is determined with a 8-bit gray scale signal for each dot.

The T260XW01 has been designed to apply the 8-bit 1 channel LVDS interface method. It is intended to support displays where high brightness, wide viewing angle, high color saturation, and high color depth are very important.

* General Information

Items	Specification	Unit	Note
Active Screen Size	26 inches		
Display Area	566.40 (H) x 339.84(V)	mm	
Outline Dimension	620.8(H) x 389.00(V) x 39.5*(D)	mm	Inverter w/ plastic shield
Driver Element	a-Si TFT active matrix		
Display Colors	16.7M	Colors	
Number of Pixels	1280 x 768	Pixel	
Pixel Arrangement	RGB vertical stripe		
Pixel Pitch (H x V)	0.4425 x 0.4425	mm	
Surface Treatment	Hard-Coating, AG		



2. Absolute Maximum Ratings

The following are maximum values which, if exceeded, may cause faulty operation or damage to the unit.

Parameter	Symbol	Min.	Max.	Unit	Note
Power Input Voltage	V _{CC}	-0.3	5.5	V _{dc}	At 25±5°C
Operating Temperature	T _{OP}	00	50	°C	1
Storage Temperature	H _{ST}	-20	60	G	1
Operating Ambient Humidity	H _{OP}	10	90	%RH	1
Storage Humidity	H _{ST}	10	90	%RH	1

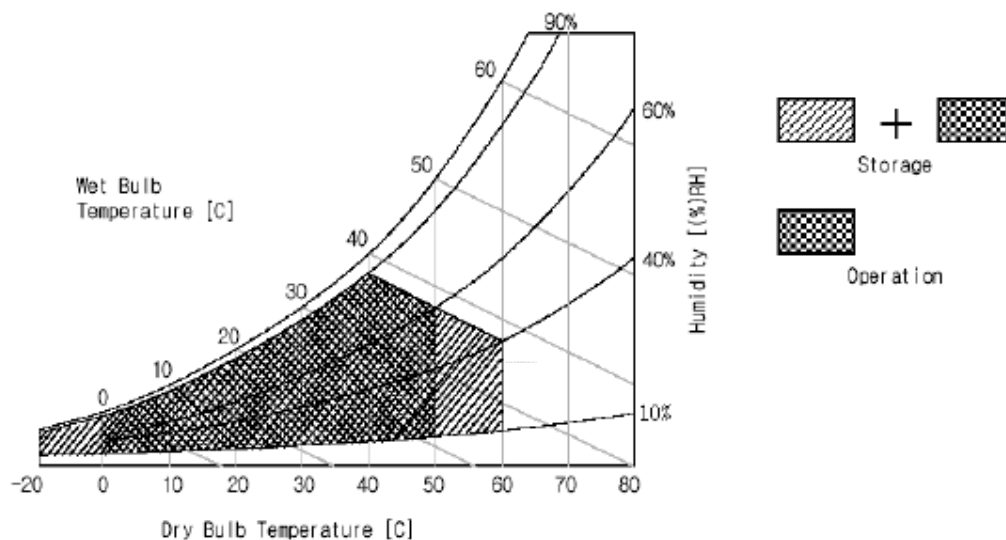

Note: The relative humidity must not exceed 90% non-condensing at temperatures of 40°C or less. At temperatures greater than 40°C, the wet bulb temperature must not exceed 39°C. When operate at low temperatures, the brightness of CCFL will drop and the life time of CCFL will be reduced.

Environment

Note: When the lamp is lighted at the conditions of ambient temperature under 0°C, there is possibility that the lamp lights pinkish.



3. Electrical Specification

3-1 Electrical Characteristics

The T260XW01 requires two power inputs. One is employed to power the LCD electronics and to drive the TFT array and liquid crystal. The second input which powers the CCFL, is typically generated by an inverter.

Parameter	Symbol	Values			Unit	Notes
		Min	Typ	Max		
LCD:						
Power Supply Input Voltage	V _{CC}	4.75	5.0	5.25	V _{dc}	
Power Supply Input Current	I _{CC}	-	1.6	2.2	A	
Power Consumption	P _C	-	8.0	11	Watt	
Inrush Current	I _{RUSH}	-	-	2.5	A _{peak}	
Backlight Power Consumption		-	94.8	124.8	W	1
Lamp Life Time		50,000	-	-		2

Note: The design of the inverter must have specifications for the lamp in LCD Assembly.

The performance of the Lamp in LCM, for example life time or brightness, is extremely influenced by the characteristics of the DC-AC Inverter. So all the parameters of an inverter should be carefully designed so as not to produce too much leakage current from high-voltage output of the inverter. When you design or order the inverter, please make sure unwanted lighting caused by the mismatch of the lamp and the inverter (no lighting, flicker, etc) never occurs. When you confirm it, the LCD Assembly should be operated in the same condition as installed in your instrument.

Note: Do not attach a conducting tape to lamp connecting wire. If the lamp wire attach to conducting tape, TFT-LCD Module have a low luminance and the inverter has abnormal action because leakage current occurs between lamp wire and conducting tape.



3-2 Interface Connections

- LCD Connector (CN1): DF19G-20P-1H (HRS) or equivalent
- Mating Connector : DF19G-20S-1H (HRS) or equivalent
- LVDS Transmitter: DS90C385 (N.S.) or THC63LVDM83A (THINE) or equivalent

Pin No.	Symbol	Function	Polarity	Output Pin #
1	Vcc	Power Supply +5.0V		
2	Vcc	Power Supply +5.0V		
3	GND	Power Ground		
4	GND	Power Ground		
5	RX0-	LVDS Receiver Signal (-)	Negative	
6	RX0+	LVDS Receiver Signal (+)	Positive	
7	GND	Ground		
8	RX1-	LVDS Receiver Signal (-)	Negative	
9	RX1+	LVDS Receiver Signal (+)	Positive	
10	GND	Ground		
11	RX2-	LVDS Receiver Signal (-)	Negative	
12	RX2+	LVDS Receiver Signal (+)	Positive	
13	GND	Ground		
14	RXCLK-	LVDS Receiver Clock Signal (-)	Negative	
15	RXCLK+	LVDS Receiver Clock Signal (+)	Positive	
16	GND	Ground		
17	RX3-	LVDS Receiver Signal (-)	Negative	
18	RX3+	LVDS Receiver Signal (+)	Positive	
19	GND	Ground		
20	NC	Reserved		

Note: 1. All GND (ground) pins should be connected together and also be connected to the LCD's metal frame.

All Vcc (power input) pins should be connected together.



I LVDS Order

1. LVDS_ORDER = L

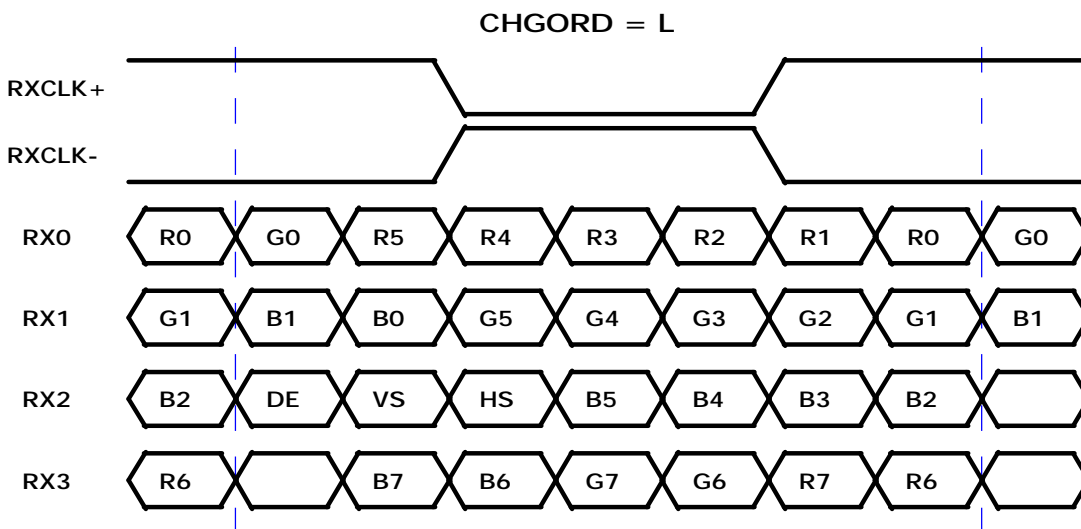

2. LVDS_ORDER = H

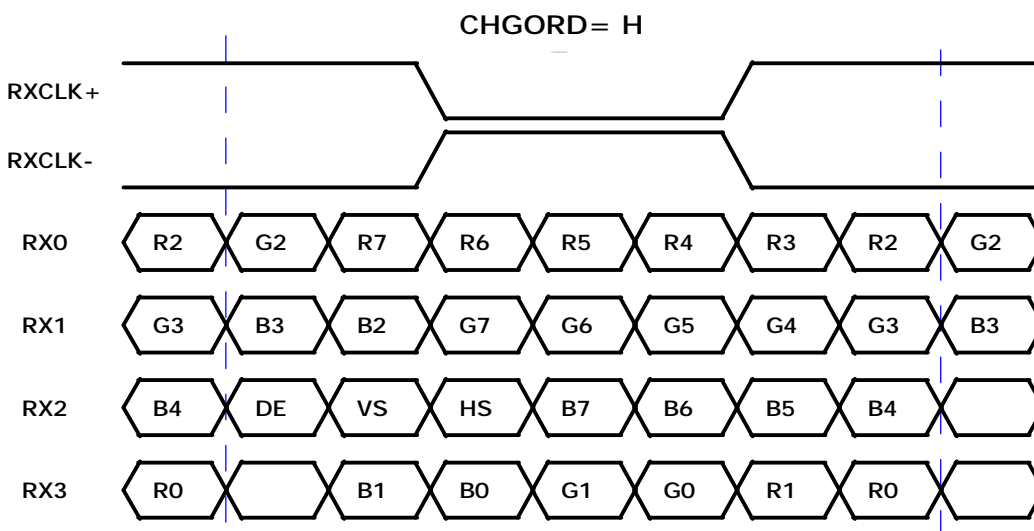



I BACKLIGHT CONNECTOR PIN CONFIGURATION -

1 · Electrical specification

(Ta=25±5°C)

No	ITEM	SYMBOL	TEST CONDITION	MIN	TYP	MAX	UNIT	MEASURING CIRCUIT	
1	Input voltage	VDDB		22.8	24.0	25.2	V		
2	Input current	IDDB	VDDB=24V,MAX brightness	3500	3950	4400	mA		
3	Oscillating frequency	F0	VDDB=24V	58	62	66	kHz		
4	PWM frequency	FBI	VDDB=24V	255	270	285	Hz		
5	ON/OFF Control voltage	ON	BLON	VDDB=24V	2.0	—	5.0	V	or OPEN
		OFF	BLON	VDDB=24V	0	—	0.8	V	
6	Dimming Control voltage	MAX	VDIM	VDDB=24V	—	1.0	—	V	
		MIN	VDIM	VDDB=24V	—	0	—	V	

2 · Input specification

CN1: S10B-PH-SM3-TB(JST)

CN2: S12B-PH-SM3-TB(JST)

No.	Signal name	Feature
1	VDDB	+24V
2	VDDB	+24V
3	VDDB	+24V
4	VDDB	+24V
5	VDDB	+24V
6	GNDB	GND
7	GNDB	GND
8	GNDB	GND
9	GNDB	GND
10	GNDB	GND

No.	Signal name	Feature	
1	VDDB	+24V	
2	VDDB	+24V	
3	VDDB	+24V	
4	VDDB	+24V	
5	VDDB	+24V	
6	GNDB	GND	
7	GNDB	GND	
8	GNDB	GND	
9	GNDB	GND	
10	GNDB	GND	
11	VDIM	Bright control	※1
12	BLON	ON/OFF Signal	※2

※1: Connection of brightness control terminal

(1)Bright control by the variable resistor

VDIM-GND short-circuit : Min. brightness

(2)Bright control by the voltage

0V : Min. brightness

1V : Max. brightness

※2: BLON Logic

H : Back Light ON

L : Back Light OFF

OPEN : Back Light ON



3-3 Input Timing Specifications

This is the signal timing required at the input of the User connector. All of the interface signal timing should be satisfied with the following specifications for its proper operation.

I Timing Table

DE only mode

Parameter	Symbol	Min.	Typ.	Max.	Unit	Condition
Clock Frequency	1/ Tc	55	65	75	MHz	
Hsync Frequency	-	47.5	48.5	49.5	KHz	
Vsync Frequency	-	47	60	66	Hz	
Horizontal	Period	TH	1340	1344	1600	clocks
	Active	THD	1280	1280	1280	clocks
Vertical	Period	TV	776	806	850	lines
	Active	TVD	768	768	768	lines

* TCH,TCL,TDS,TDH,TES : refer to timing specification of LVDS Tx chip.

Timing diagrams of interface signal (DE only mode)

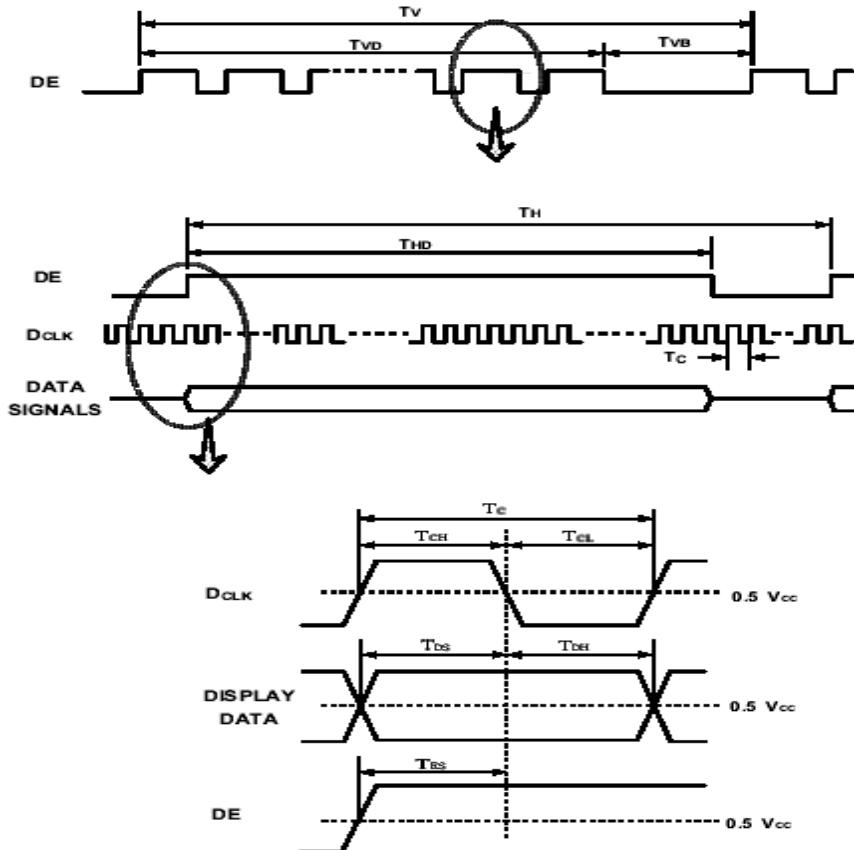



3-4 Color Input Data Reference

The brightness of each primary color (red, green and blue) is based on the 8 bit gray scale data input for the color; the higher the binary input, the brighter the color. The table below provides a reference for color versus data input.

COLOR DATA REFERENCE

Color		Input Color Data																							
		RED								GREEN						BLUE									
		MSB				LSB				MSB			LSB			MSB			LSB						
		R7	R6	R5	R4	R3	R2	R1	R0	G7	G6	G5	G4	G3	G2	G1	G0	B7	B6	B5	B4	B3	B2	B1	B0
Basic Color	Black	0	0	0	0	0	0	0	0	0	0	0	0	0	0	0	0	0	0	0	0	0	0	0	0
	Red(255)	1	1	1	1	1	1	1	1	0	0	0	0	0	0	0	0	0	0	0	0	0	0	0	0
	Green(255)	0	0	0	0	0	0	0	0	1	1	1	1	1	1	1	1	0	0	0	0	0	0	0	0
	Blue(255)	0	0	0	0	0	0	0	0	0	0	0	0	0	0	0	0	1	1	1	1	1	1	1	1
	Cyan	0	0	0	0	0	0	0	0	1	1	1	1	1	1	1	1	1	1	1	1	1	1	1	1
	Magenta	1	1	1	1	1	1	1	1	0	0	0	0	0	0	0	0	1	1	1	1	1	1	1	1
	Yellow	1	1	1	1	1	1	1	1	1	1	1	1	1	1	1	1	0	0	0	0	0	0	0	0
White	1	1	1	1	1	1	1	1	1	1	1	1	1	1	1	1	1	1	1	1	1	1	1	1	
RED	RED(000)	0	0	0	0	0	0	0	0	0	0	0	0	0	0	0	0	0	0	0	0	0	0	0	0
	RED(001)	0	0	0	0	0	0	0	0	0	0	0	0	0	0	0	0	0	0	0	0	0	0	0	0

	RED(254)	1	1	1	1	1	1	1	0	0	0	0	0	0	0	0	0	0	0	0	0	0	0	0	0
	RED(255)	1	1	1	1	1	1	1	1	0	0	0	0	0	0	0	0	0	0	0	0	0	0	0	0
GREEN	GREEN(000)	0	0	0	0	0	0	0	0	0	0	0	0	0	0	0	0	0	0	0	0	0	0	0	0
	GREEN(001)	0	0	0	0	0	0	0	0	0	0	0	0	0	0	0	1	0	0	0	0	0	0	0	0

	GREEN(254)	0	0	0	0	0	0	0	0	1	1	1	1	1	1	1	0	0	0	0	0	0	0	0	0
	GREEN(255)	0	0	0	0	0	0	0	0	1	1	1	1	1	1	1	1	0	0	0	0	0	0	0	0
BLUE	BLUE(000)	0	0	0	0	0	0	0	0	0	0	0	0	0	0	0	0	0	0	0	0	0	0	0	0
	BLUE(001)	0	0	0	0	0	0	0	0	0	0	0	0	0	0	0	0	0	0	0	0	0	0	0	1

	BLUE(254)	0	0	0	0	0	0	0	0	0	0	0	0	0	0	0	0	1	1	1	1	1	1	1	0
	BLUE(255)	0	0	0	0	0	0	0	0	0	0	0	0	0	0	0	0	1	1	1	1	1	1	1	1



3-5 Power Sequence

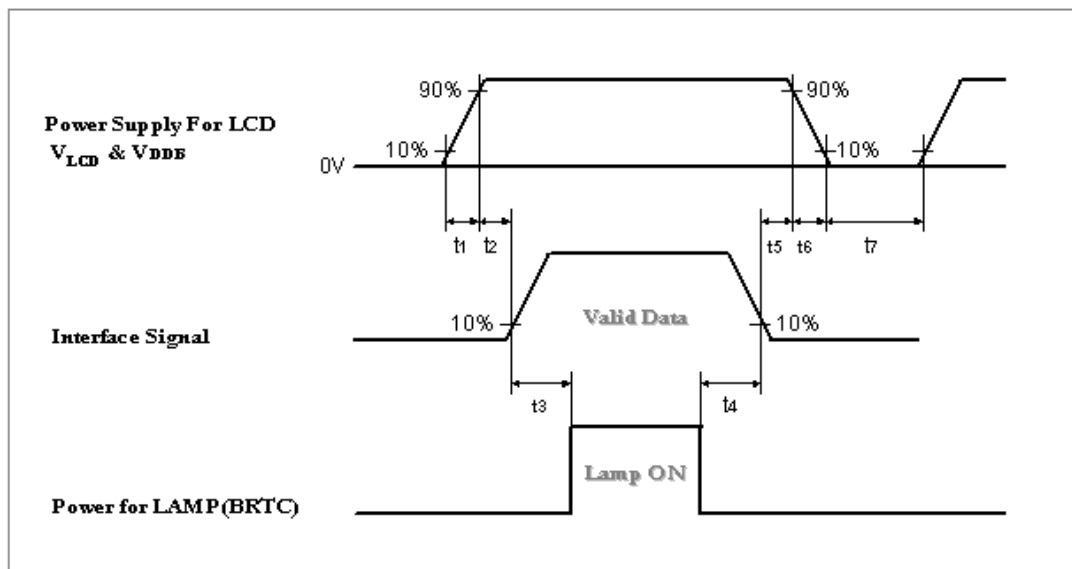

Parameter	Values			Units
	Min.	Typ.	Max.	
t1	470	-	1000	us
t2	5	-	-	ms
t3	200	-	-	ms
t4	200	-	-	ms
t5	5	-	-	ms
t6	-	-	30	ms
t7	1	-	-	s

Note: User should follow the power on/off sequence and the rising/falling time to avoid miss operation of the panel.



4. Optical Specification

Optical characteristics are determined after the unit has been 'ON' and stable for approximately 30 minutes in a dark environment at 25°C. The values specified are at an approximate distance 50cm from the LCD surface at a viewing angle of Φ and θ equal to 0°.

Fig.1 1 presents additional information concerning the measurement equipment and method.

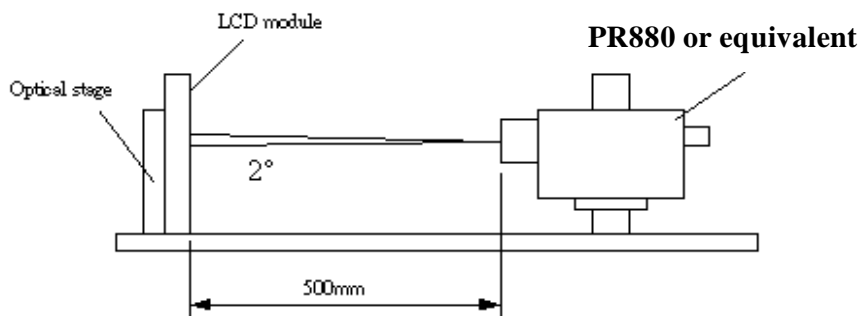

Parameter	Symbol	Values			Units	Notes	
		Min.	Typ.	Max.			
Contrast Ratio	CR	500	600			1	
Surface Luminance, white	LWH	400	500		cd/m ²	2	
Response Time	Gray to Gray	-	12	45	ms		
	Tr	-	15	18		3	
	Tf	-	10	13		3	
Color Chromaticity	RED	R _X	Typ.-0.03	0.647	Typ.+0.03		
		R _Y		0.339			
	GREEN	G _X		0.296			
		G _Y		0.613			
	BLUE	B _X		0.138			
		B _Y		0.075			
	WHITE	W _X		0.301			
		W _Y		0.327			
Viewing Angle							
	x axis, right($\varphi=0^\circ$)	θ_r	80	85	-	Degree	4
	x axis, left($\varphi=180^\circ$)	θ_l	80	85	-		
	y axis, up($\varphi=90^\circ$)	θ_u	80	85	-		
	y axis, down ($\varphi=0^\circ$)	θ_d	80	85	-		
White Uniformity	δW	70	80	-	%	5	



Note:

1. Contrast Ratio (CR) is defined mathematically as:

$$\text{Contrast Ratio} = \frac{\text{Surface Luminance with all white pixels}}{\text{Surface Luminance with all black pixels}}$$

2. Surface luminance is luminance value at point 1 across the LCD surface 50cm from the surface with all pixels displaying white. (FIG2)

3. Response time is the time required for the display to transition from white to black (Rise Time, T_{R}) and from black to white (Decay Time, T_{D}). For additional information see FIG3.

4. Viewing angle is the angle at which the contrast ratio is greater than 5. The angles are determined for the horizontal or x axis and the vertical or y axis with respect to the z axis which is normal to the LCD surface. For more information see FIG4.

5. Definition of white uniformity:

White uniformity is calculated with the following formula.
Luminance are measured at the following five points (1~5).

$$\delta_w = \frac{\text{Minimum Brightness of five points}}{\text{Maximum Brightness of five points}}$$



FIG. 2 Luminance

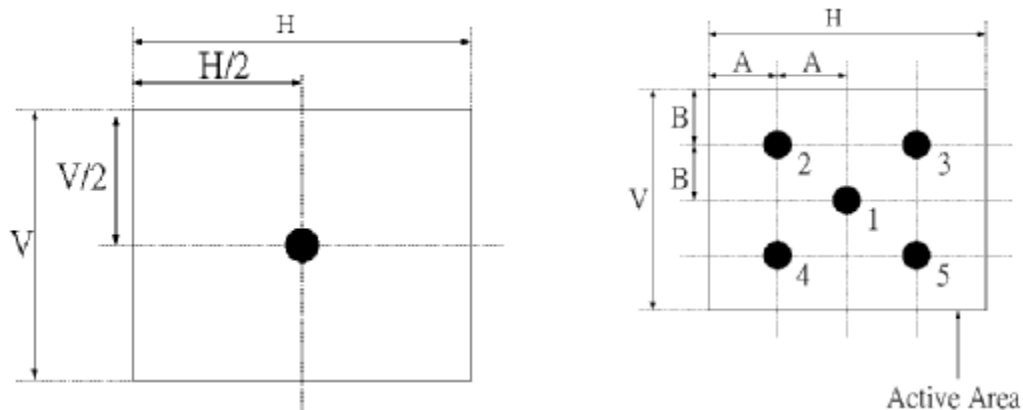

FIG.3 Response Time

The response time is defined as the following figure and shall be measured by switching the input signal for “black” and “white”. The gray to gray response time is only available between 33~223 gray level because of material limitation

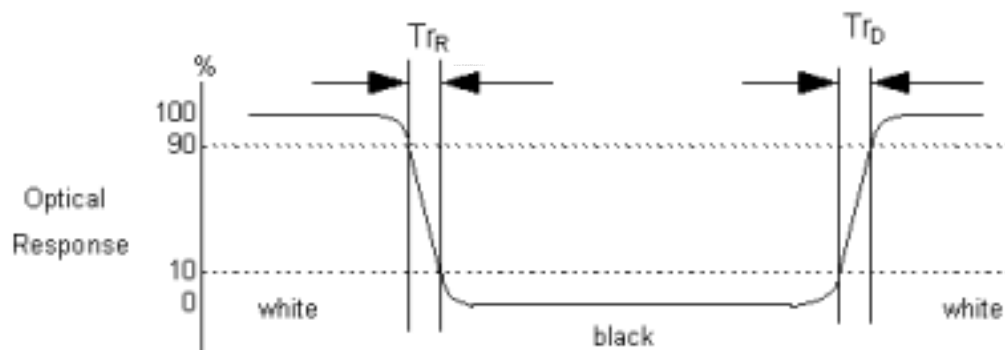
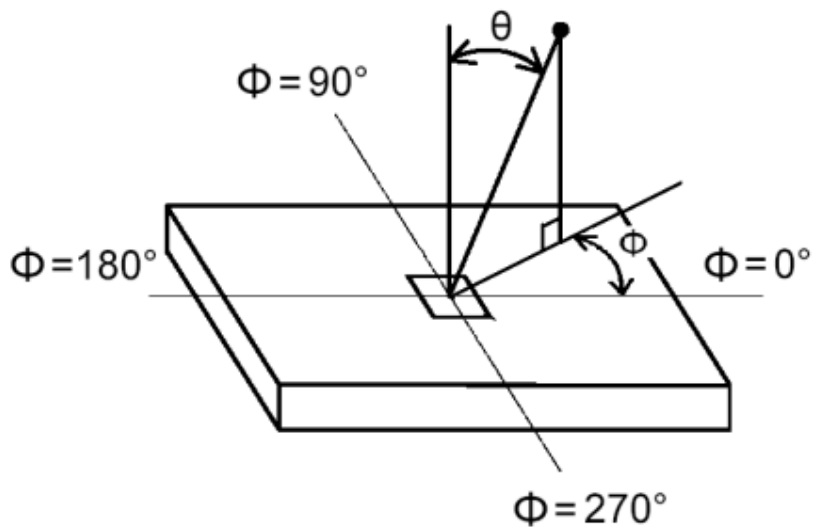



FIG.4 Viewing angle





5. Mechanical Characteristics

The contents provide general mechanical characteristics for the model T260XW01. In addition the figures in the next page are detailed mechanical drawing of the LCD.

Outline Dimension	Horizontal	620.8mm
	Vertical	389.00mm
	Depth	39.50mm(w/I inverter) 33.50mm(w/o inverter)
Bezel Area	Horizontal	570.40mm
	Vertical	343.84mm
Active Display Area	Horizontal	566.40mm
	Vertical	339.84mm
Weight	4000g (Typ.)	
Surface Treatment	Hard Coating, AG	

Note: Suggest to fix this panel via side mount as well as front mount simultaneously.



Rear View

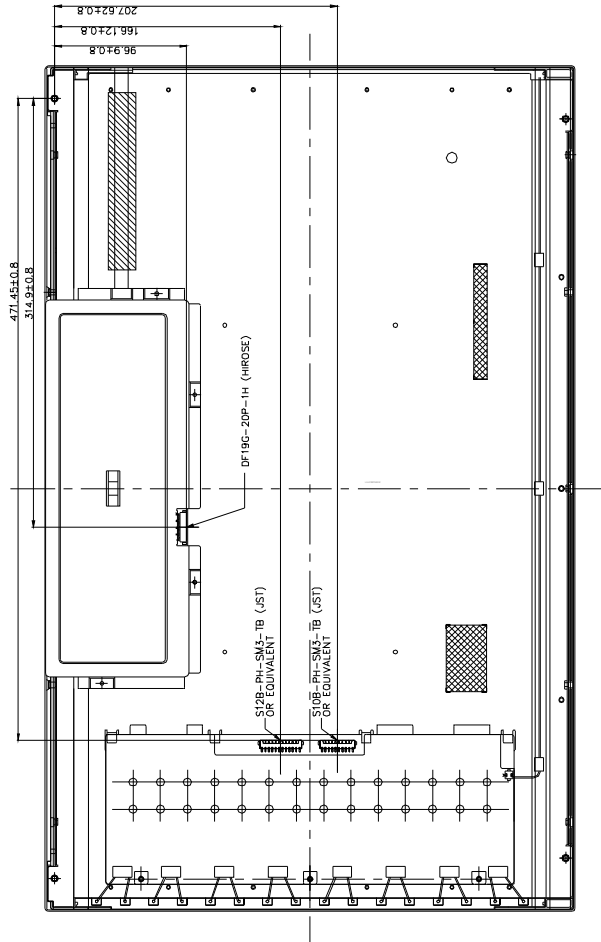



6. Reliability

Environment test condition

No	Test Item	Condition	Remark
1	High temperature storage test	Ta= 60°C 240h	Note 1,2,3
2	Low temperature storage test	Ta= -20°C 240h	Note 1,2,3
3	High temperature operation test	Ta=50°C 50%RH 240h	Note 1,2,3
4	Low temperature operation test	Ta=0°C 240h	Note 1,2,3
5	Thermal Shock Test	-20°C ~60°C 1H, 10mins, 1H, 5cycles	Note 1,2,3
6	Electrostatic discharge (non-operation)	150 pF,150Ω,10kV,1 second, 9 position on the panel, 10 times each place	Note 3
7	Vibration test (non-operating)	Wave form: random Vibration level : 1.0G RMS Bandwidth : 10-500Hz Duration: X, Y, Z 10min One time each direction	Note 1,2,3
8	Shock test (non-operating)	Shock level: 100G Waveform: half sine wave, 2ms Direction: ±X, ±Y, ±Z One time each direction	Note 1,2,3

Note 1: Evaluation should be tested after storage at room temperature for one hour.

Note 2: There should be no change which might affect the practical display function when the display quality test is conducted under normal operating condition.

Note 3: Judgment: (a) Function OK.

(b). No serious image quality degradation.



7. International Standard

7-1. Safety

- (1) UL1950 Third Edition, Underwriters Laboratories, Inc. Jan. 28, 1995
Standard for Safety of Information Technology Equipment Including electrical Business Equipment.
- (2) CAN/CSA C22.2 No. 950-95 Third Edition, Canadian Standards Association, Jan. 28, 1995
Standard for Safety of Information Technology Equipment Including Electrical Business Equipment.
- (3) EN60950 : 1992+A2: 1993+A2: 1993+C3: 1995+A4: 1997+A11: 1997
IEC 950: 1991+A1: 1992+A2: 1993+C3: 1995+A4:1996
European Committee for Electrotechnical Standardization (CENELEC)
EUROPEAN STANDARD for Safety of Information Technology Equipment Including Electrical
Business Equipment.

7-2. EMC

- a) ANSI C63.4 “Methods of Measurement of Radio-Noise Emissions from Low-Voltage Electrical and Electrical Equipment in the Range of 9kHz to 40GHz. “American National standards Institute(ANSI), 1992
- b) C.I.S.P.R “Limits and Methods of Measurement of Radio Interface Characteristics of Information Technology Equipment.” International Special committee on Radio Interference.
- c) EN 55022 “Limits and Methods of Measurement of Radio Interface Characteristics of Information Technology Equipment.” European Committee for Electrotechnical Standardization. (CENELEC), 1998



8. Packing

(1) Label Sample



(2) Carton Label



(3) Carton Size

The outside dimension of carton is 767(L) mm * 270(W) mm * 490(H) mm.

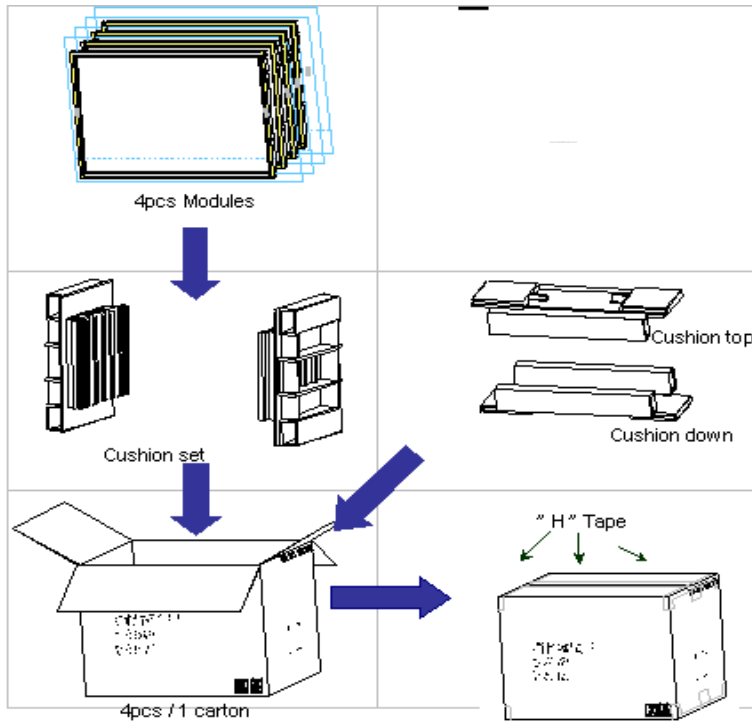



9. PRECAUTIONS

Please pay attention to the followings when you use this TFT LCD module.

9-1 MOUNTING PRECAUTIONS

- (1) You must mount a module using holes arranged in four corners and four sides.
- (2) You should consider the mounting structure so that uneven force (ex. Twisted stress) is not applied to module. And the case on which a module is mounted should have sufficient strength so that external force is not transmitted directly to the module.
- (3) Please attach the surface transparent protective plate to the surface in order to protect the polarizer. Transparent protective plate should have sufficient strength in order to resist external force.
- (4) You should adopt radiation structure to satisfy the temperature specification.
- (5) Acetic acid type and chlorine type materials for the cover case are not desirable because the former generates corrosive gas of attacking the polarizer at high temperature and the latter causes circuit break by electro-chemical reaction.
- (6) Do not touch, push or rub the exposed polarizers with glass, tweezers or anything harder than HB pencil lead. And please do not rub with dust clothes with chemical treatment. Do not touch the surface of polarizer for bare hand or greasy cloth. (Some cosmetics are detrimental to the polarizer.)
- (7) When the surface becomes dusty, please wipe gently with absorbent cotton or other soft materials like chamois soaks with petroleum benzene. Normal-hexane is recommended for cleaning the adhesives used to attach front/ rear polarizers. Do not use acetone, toluene and alcohol because they cause chemical damage to the polarizer.
- (8) Wipe off saliva or water drops as soon as possible. Their long time contact with polarizer causes deformations and color fading.
- (9) Do not open the case because inside circuits do not have sufficient strength.

9-2 OPERATING PRECAUTIONS

- (1) The spike noise causes the mis-operation of circuits. It should be lower than following voltage:
 $V = \pm 200\text{mV}$ (Over and under shoot voltage)
- (2) Response time depends on the temperature. (In lower temperature, it becomes longer..)
- (3) In lower temperature, response time (required time that brightness is stable after turned on) becomes longer and it might effect the brightness.
- (4) Be careful for condensation at sudden temperature change. Condensation makes damage to polarizer or electrical contacted parts. And after fading condensation, smear or spot will occur.
- (5) When fixed patterns are displayed for a long time, remnant image is likely to occur.
- (6) Module has high frequency circuits. Sufficient suppression to the electromagnetic interference shall be done by system manufacturers. Grounding and shielding methods may be important to minimize the interface.

9-3 ELECTROSTATIC DISCHARGE CONTROL

Since a module is composed of electronic circuits, it is not strong to electrostatic discharge. Make certain that treatment persons are connected to ground through wrist band etc. And don't touch interface pin directly.

9-4 PRECAUTIONS FOR STRONG LIGHT EXPOSURE

Strong light exposure causes degradation of polarizer and color filter.

9-5 STORAGE

When storing modules as spares for a long time, the following precautions are necessary.

- (1) Store them in a dark place. Do not expose the module to sunlight or fluorescent light. Keep the temperature between 5°C and 35°C at normal humidity.
- (2) The polarizer surface should not come in contact with any other object. It is recommended that they be stored in the container in which they were shipped.

9-6 HANDLING PRECAUTIONS FOR PROTECTION FILM

- (1) The protection film is attached to the bezel with a small masking tape. When the protection film is peeled off, static electricity is generated between the film and polarizer. This should be peeled off slowly and carefully by people who are electrically grounded and with well ion-blown equipment or in such a condition, etc.
- (2) When the module with protection film attached is stored for a long time, sometimes there remains a very small amount of glue still on the Bezel after the protection film is peeled off.
- (3) You can remove the glue easily. When the glue remains on the Bezel or its vestige is recognized, please wipe them off with absorbent cotton waste or other soft material like chamois soaked with normal-hexane.