

■ General Description

The AME8801/8812/8840 family of positive, linear regulators feature low quiescent current (30µA typ.) with low dropout voltage, making them ideal for battery applications. The space-saving SOT-25/TSOT-25 & SOT-26/TSOT-26 packages are attractive for "Pocket" and "Hand Held" applications.

These rugged devices have both Thermal Shutdown, and Current Fold-back to prevent device failure under the "Worst" operating conditions.

In applications requiring a low noise, regulated supply, place a 1000 pF capacitor between Bypass and Ground.

The AME8801 is stable with an output capacitance of 2.2µF or greater.

■ Features

- Very Low Dropout Voltage
- Guaranteed 300mA Output
- Accurate to within 1.5%
- 30µA Quiescent Current
- Over-Temperature Shutdown
- Current Limiting
- Short Circuit Current Fold-back
- Noise Reduction Bypass Capacitor
- Power-Saving Shutdown Mode
- Space-Saving SOT-25/TSOT-25, SOT-26/TSOT-26 Packages
- Factory Pre-set Output Voltages
- Low Temperature Coefficient
- All AME's Lead Free Product Meet RoHS Standards

■ Applications

- Instrumentation
- Portable Electronics
- Wireless Devices
- Cordless Phones
- PC Peripherals
- Battery Powered Widgets

■ Functional Block Diagram

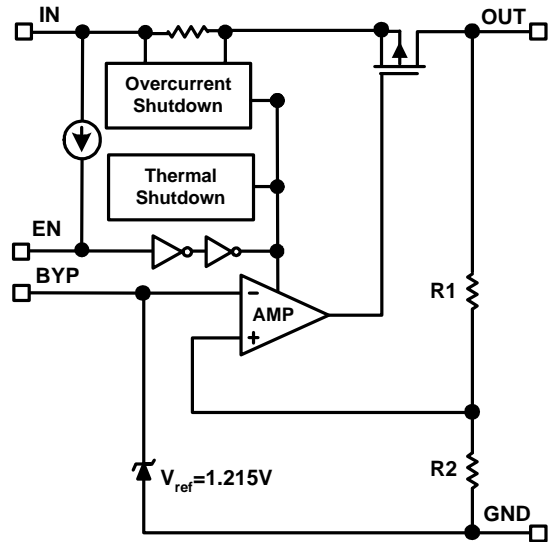

■ Typical Application

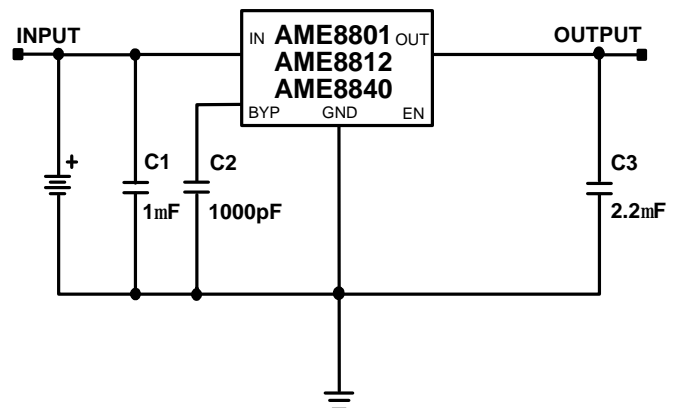

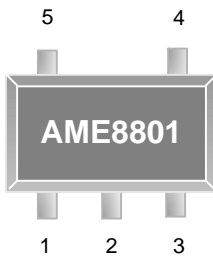
■ Pin Configuration
**SOT-25/TSOT-25
Top View**

AME8801

1. IN
2. GND
3. EN
4. BYP
5. OUT

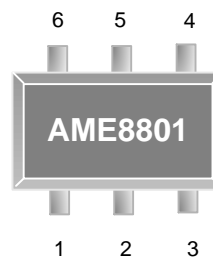
*** Die Attach:
Conductive Epoxy**

**SOT-26/TSOT-26
Top View**

AME8801

1. OUT1
2. GND
3. BYP
4. EN
5. IN
6. OUT2

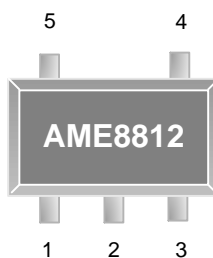
*** Die Attach:
Non-Conductive Epoxy**

**SOT-25/TSOT-25
Top View**

AME8812

1. EN
2. GND
3. IN
4. OUT
5. BYP

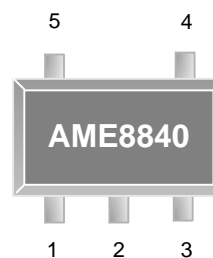
*** Die Attach:
Conductive Epoxy**

**SOT-25/TSOT-25
Top View**

AME8840

1. EN
2. GND
3. BYP
4. OUT
5. IN

*** Die Attach:
Conductive Epoxy**

■ Pin Description

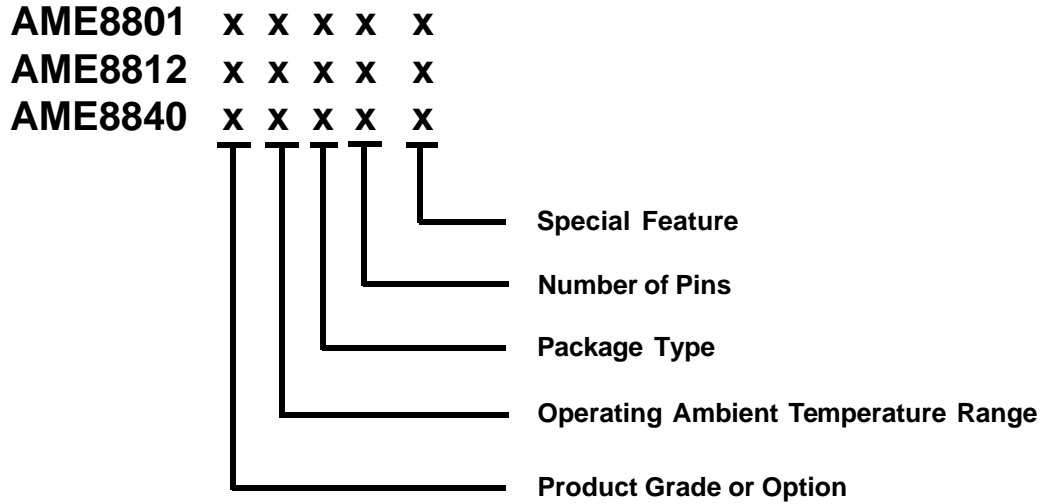
Pin Name	Pin Description
IN	Input voltage pin. It should be decoupled with 1 μ F or greater capacitor.
GND	Ground connection pin.
EN	Enable pin. When pulled low, the PMOS pass transistor turns off, current consuming less than 1 μ A.
BYP	Bypass capacitor connection. To improve AC ripple rejection, connect a capacitor to GND. This will also provide a soft-start function.
OUT	LDO voltage regulator output pin. It should be decoupled with a 1 μ F or greater value low ESR ceramic capacitor.

■ Ordering Information

Product Grade or Option	Operating Ambient Temperature Range	Package Type	Number of Pins	Special Feature
A: 3.3V 1: 1.3V B: 3.0V 2: 2.0V C: 2.8V 3: 4.2V D: 2.5V 4: 4.0V E: 3.8V 6: 3.45V F: 3.6V G: 3.5V H: 2.7V I: 3.4V J: 2.85V K: 3.7V L: 1.5V M: 1.8V N: 2.9V O: 3.1V P: 4.1V Q: 4.75V R: 2.65V S: 5.0V U: 3.2V V: 3.15V W: 2.3V Y: 1.9V Z: 1.7V	E: -40°C to +85°C	E: SOT-2X	V: 5 Y: 6	L: Low Profile Y: Lead Free & Low Profile Z: Lead Free

■ Ordering Information

Part Number	Marking*	Output Voltage	Package	Operating Ambient Temperature Range
AME88012EEV	AWKww	2.0V	SOT-25	- 40°C to +85°C
AME88012EEVL	AWKww	2.0V	TSOT-25	- 40°C to +85°C
AME88012EEVZ	AWKww	2.0V	SOT-25	- 40°C to +85°C
AME88012EEVY	AWKww	2.0V	TSOT-25	- 40°C to +85°C
AME8801AEEV	AAFww	3.3V	SOT-25	- 40°C to +85°C
AME8801AEEVL	AAFww	3.3V	TSOT-25	- 40°C to +85°C
AME8801AEEVZ	AAFww	3.3V	SOT-25	- 40°C to +85°C
AME8801AEEVY	AAFww	3.3V	TSOT-25	- 40°C to +85°C
AME8801BEEV	AAGww	3.0V	SOT-25	- 40°C to +85°C
AME8801BEEVL	AAGww	3.0V	TSOT-25	- 40°C to +85°C
AME8801BEEVZ	AAGww	3.0V	SOT-25	- 40°C to +85°C
AME8801BEEVY	AAGww	3.0V	TSOT-25	- 40°C to +85°C
AME8801CEEV	AAHww	2.8V	SOT-25	- 40°C to +85°C
AME8801CEEVL	AAHww	2.8V	TSOT-25	- 40°C to +85°C
AME8801CEEVZ	AAHww	2.8V	SOT-25	- 40°C to +85°C
AME8801CEEVY	AAHww	2.8V	TSOT-25	- 40°C to +85°C
AME8801DEEV	AAIww	2.5V	SOT-25	- 40°C to +85°C
AME8801DEEVL	AAIww	2.5V	TSOT-25	- 40°C to +85°C
AME8801DEEVZ	AAIww	2.5V	SOT-25	- 40°C to +85°C
AME8801DEEVY	AAIww	2.5V	TSOT-25	- 40°C to +85°C
AME8801EEEV	AAJww	3.8V	SOT-25	- 40°C to +85°C
AME8801EEEVL	AAJww	3.8V	TSOT-25	- 40°C to +85°C
AME8801EEEVZ	AAJww	3.8V	SOT-25	- 40°C to +85°C
AME8801EEEVY	AAJww	3.8V	TSOT-25	- 40°C to +85°C
AME8801FEEV	ABOww	3.6V	SOT-25	- 40°C to +85°C
AME8801FEEVL	ABOww	3.6V	TSOT-25	- 40°C to +85°C
AME8801FEEVZ	ABOww	3.6V	SOT-25	- 40°C to +85°C
AME8801FEEVY	ABOww	3.6V	TSOT-25	- 40°C to +85°C

Note: ww represents the date code and pls refer to Date Code Rule on Package Dimension.

* A line on top of the first letter represents lead free plating such as $\overline{\text{AWK}}$ ww.

Please consult AME sales office or authorized Rep./Distributor for the availability of package type.

■ Ordering Information (contd.)

Part Number	Marking*	Output Voltage	Package	Operating Ambient Temperature Range
AME8801GEEV	ACFww	3.5V	SOT-25	- 40°C to +85°C
AME8801GEEVL	ACFww	3.5V	TSOT-25	- 40°C to +85°C
AME8801GEEVZ	ACFww	3.5V	SOT-25	- 40°C to +85°C
AME8801GEEVY	ACFww	3.5V	TSOT-25	- 40°C to +85°C
AME8801HEEV	AEGww	2.7V	SOT-25	- 40°C to +85°C
AME8801HEEVL	AEGww	2.7V	TSOT-25	- 40°C to +85°C
AME8801HEEVZ	AEGww	2.7V	SOT-25	- 40°C to +85°C
AME8801HEEVY	AEGww	2.7V	TSOT-25	- 40°C to +85°C
AME8801IEEV	AEOww	3.4V	SOT-25	- 40°C to +85°C
AME8801IEEVL	AEOww	3.4V	TSOT-25	- 40°C to +85°C
AME8801IEEVZ	AEOww	3.4V	SOT-25	- 40°C to +85°C
AME8801IEEVY	AEOww	3.4V	TSOT-25	- 40°C to +85°C
AME8801JEEV	AGQww	2.85V	SOT-25	- 40°C to +85°C
AME8801JEEVL	AGQww	2.85V	TSOT-25	- 40°C to +85°C
AME8801JEEVZ	AGQww	2.85V	SOT-25	- 40°C to +85°C
AME8801JEEVY	AGQww	2.85V	TSOT-25	- 40°C to +85°C
AME8801KEEV	AHSww	3.7V	SOT-25	- 40°C to +85°C
AME8801KEEVL	AHSww	3.7V	TSOT-25	- 40°C to +85°C
AME8801KEEVZ	AHSww	3.7V	SOT-25	- 40°C to +85°C
AME8801KEEVY	AHSww	3.7V	TSOT-25	- 40°C to +85°C
AME8801LEEV	AJOww	1.5V	SOT-25	- 40°C to +85°C
AME8801LEEVL	AJOww	1.5V	TSOT-25	- 40°C to +85°C
AME8801LEEVZ	AJOww	1.5V	SOT-25	- 40°C to +85°C
AME8801LEEVY	AJOww	1.5V	TSOT-25	- 40°C to +85°C
AME8801MEEV	AJPww	1.8V	SOT-25	- 40°C to +85°C
AME8801MEEVL	AJPww	1.8V	TSOT-25	- 40°C to +85°C
AME8801MEEVZ	AJPww	1.8V	SOT-25	- 40°C to +85°C
AME8801MEEVY	AJPww	1.8V	TSOT-25	- 40°C to +85°C
AME8801NEEV	AKOww	2.9V	SOT-25	- 40°C to +85°C
AME8801NEEVL	AKOww	2.9V	TSOT-25	- 40°C to +85°C
AME8801NEEVZ	AKOww	2.9V	SOT-25	- 40°C to +85°C

■ Ordering Information (contd.)

Part Number	Marking*	Output Voltage	Package	Operating Ambient Temperature Range
AME8801NEEVY	AKOww	2.9V	TSOT-25	- 40°C to +85°C
AME8801OEEV	AKPww	3.1V	SOT-25	- 40°C to +85°C
AME8801OEEVL	AKPww	3.1V	TSOT-25	- 40°C to +85°C
AME8801OEEVZ	AKPww	3.1V	SOT-25	- 40°C to +85°C
AME8801OEEVY	AKPww	3.1V	TSOT-25	- 40°C to +85°C
AME8801SEEV	AQXww	5.0V	SOT-25	- 40°C to +85°C
AME8801SEEVL	AQXww	5.0V	TSOT-25	- 40°C to +85°C
AME8801SEEVZ	AQXww	5.0V	SOT-25	- 40°C to +85°C
AME8801SEEVY	AQXww	5.0V	TSOT-25	- 40°C to +85°C
AME8801UEEV	AXAww	5.0V	SOT-25	- 40°C to +85°C
AME8801UEEVL	AXAww	5.0V	TSOT-25	- 40°C to +85°C
AME8801UEEVZ	AXAww	5.0V	SOT-25	- 40°C to +85°C
AME8801UEEVY	AXAww	5.0V	TSOT-25	- 40°C to +85°C
AME8801JEEY	ARUww	2.85V	SOT-26	- 40°C to +85°C
AME8801JEEYL	ARUww	2.85V	TSOT-26	- 40°C to +85°C
AME8801JEEYZ	ARUww	2.85V	SOT-26	- 40°C to +85°C
AME8801JEEYY	ARUww	2.85V	TSOT-26	- 40°C to +85°C
AME8812AEEV	ASEww	3.3V	SOT-25	- 40°C to +85°C
AME8812AEEVL	ASEww	3.3V	TSOT-25	- 40°C to +85°C
AME8812AEEVZ	ASEww	3.3V	SOT-25	- 40°C to +85°C
AME8812AEEVY	ASEww	3.3V	TSOT-25	- 40°C to +85°C
AME8812BEEV	ASFww	3.0V	SOT-25	- 40°C to +85°C
AME8812BEEVL	ASFww	3.0V	TSOT-25	- 40°C to +85°C
AME8812BEEVZ	ASFww	3.0V	SOT-25	- 40°C to +85°C
AME8812BEEVY	ASFww	3.0V	TSOT-25	- 40°C to +85°C
AME8812CEEV	AUGww	2.8V	SOT-25	- 40°C to +85°C
AME8812CEEVL	AUGww	2.8V	TSOT-25	- 40°C to +85°C
AME8812CEEVZ	AUGww	2.8V	SOT-25	- 40°C to +85°C
AME8812CEEVY	AUGww	2.8V	TSOT-25	- 40°C to +85°C
AME8812DEEV	ARSww	2.5V	SOT-25	- 40°C to +85°C
AME8812DEEVL	ARSww	2.5V	TSOT-25	- 40°C to +85°C

■ Ordering Information (contd.)

Part Number	Marking*	Output Voltage	Package	Operating Ambient Temperature Range
AME8812DEEVZ	ARSww	2.5V	SOT-25	- 40°C to +85°C
AME8812DEEVY	ARSww	2.5V	TSOT-25	- 40°C to +85°C
AME8812EEEEV	AUHww	3.8V	SOT-25	- 40°C to +85°C
AME8812EEEEVL	AUHww	3.8V	TSOT-25	- 40°C to +85°C
AME8812EEEEVZ	AUHww	3.8V	SOT-25	- 40°C to +85°C
AME8812EEEEVY	AUHww	3.8V	TSOT-25	- 40°C to +85°C
AME8812FEEV	AUIww	3.6V	SOT-25	- 40°C to +85°C
AME8812FEEVL	AUIww	3.6V	TSOT-25	- 40°C to +85°C
AME8812FEEVZ	AUIww	3.6V	SOT-25	- 40°C to +85°C
AME8812FEEVY	AUIww	3.6V	TSOT-25	- 40°C to +85°C
AME8812GEEV	AUJww	3.5V	SOT-25	- 40°C to +85°C
AME8812GEEVL	AUJww	3.5V	TSOT-25	- 40°C to +85°C
AME8812GEEVZ	AUJww	3.5V	SOT-25	- 40°C to +85°C
AME8812GEEVY	AUJww	3.5V	TSOT-25	- 40°C to +85°C
AME8812HEEV	AUKww	2.7V	SOT-25	- 40°C to +85°C
AME8812HEEVL	AUKww	2.7V	TSOT-25	- 40°C to +85°C
AME8812HEEVZ	AUKww	2.7V	SOT-25	- 40°C to +85°C
AME8812HEEVY	AUKww	2.7V	TSOT-25	- 40°C to +85°C
AME8812IEEV	AULww	3.4V	SOT-25	- 40°C to +85°C
AME8812IEEVL	AULww	3.4V	TSOT-25	- 40°C to +85°C
AME8812IEEVZ	AULww	3.4V	SOT-25	- 40°C to +85°C
AME8812IEEVY	AULww	3.4V	TSOT-25	- 40°C to +85°C
AME8812JEEV	ARFww	2.85V	SOT-25	- 40°C to +85°C
AME8812JEEVL	ARFww	2.85V	TSOT-25	- 40°C to +85°C
AME8812JEEVZ	ARFww	2.85V	SOT-25	- 40°C to +85°C
AME8812JEEVY	ARFww	2.85V	TSOT-25	- 40°C to +85°C
AME8812KEEV	AUMww	3.7V	SOT-25	- 40°C to +85°C
AME8812KEEVL	AUMww	3.7V	TSOT-25	- 40°C to +85°C
AME8812KEEVZ	AUMww	3.7V	SOT-25	- 40°C to +85°C
AME8812KEEVY	AUMww	3.7V	TSOT-25	- 40°C to +85°C
AME8812LEEV	AUNww	1.5V	SOT-25	- 40°C to +85°C

■ Ordering Information (contd.)

Part Number	Marking*	Output Voltage	Package	Operating Ambient Temperature Range
AME8812LEEV	AUNww	1.5V	TSOT-25	- 40°C to +85°C
AME8812LEEVZ	AUNww	1.5V	SOT-25	- 40°C to +85°C
AME8812LEEVY	AUNww	1.5V	TSOT-25	- 40°C to +85°C
AME8812MEEV	AUOww	1.8V	SOT-25	- 40°C to +85°C
AME8812MEEVL	AUOww	1.8V	TSOT-25	- 40°C to +85°C
AME8812MEEVZ	AUOww	1.8V	SOT-25	- 40°C to +85°C
AME8812MEEVY	AUOww	1.8V	TSOT-25	- 40°C to +85°C
AME8812NEEV	AUPww	2.9V	SOT-25	- 40°C to +85°C
AME8812NEEVL	AUPww	2.9V	TSOT-25	- 40°C to +85°C
AME8812NEEVZ	AUPww	2.9V	SOT-25	- 40°C to +85°C
AME8812NEEVY	AUPww	2.9V	TSOT-25	- 40°C to +85°C
AME8812OEEV	AUQww	3.1V	SOT-25	- 40°C to +85°C
AME8812OEEVL	AUQww	3.1V	TSOT-25	- 40°C to +85°C
AME8812OEEVZ	AUQww	3.1V	SOT-25	- 40°C to +85°C
AME8812OEEVY	AUQww	3.1V	TSOT-25	- 40°C to +85°C
AME8812SEEV	AURww	5.0V	SOT-25	- 40°C to +85°C
AME8812SEEV	AURww	5.0V	TSOT-25	- 40°C to +85°C
AME8812SEEVZ	AURww	5.0V	SOT-25	- 40°C to +85°C
AME8812SEEVY	AURww	5.0V	TSOT-25	- 40°C to +85°C
AME8840AEEV	ALCww	3.3V	SOT-25	- 40°C to +85°C
AME8840AEEVL	ALCww	3.3V	TSOT-25	- 40°C to +85°C
AME8840AEEVZ	ALCww	3.3V	SOT-25	- 40°C to +85°C
AME8840AEEVY	ALCww	3.3V	TSOT-25	- 40°C to +85°C
AME8840BEEV	ALDww	3.0V	SOT-25	- 40°C to +85°C
AME8840BEEVL	ALDww	3.0V	TSOT-25	- 40°C to +85°C
AME8840BEEVZ	ALDww	3.0V	SOT-25	- 40°C to +85°C
AME8840BEEVY	ALDww	3.0V	TSOT-25	- 40°C to +85°C
AME8840CEEV	ALEww	2.8V	SOT-25	- 40°C to +85°C
AME8840CEEVL	ALEww	2.8V	TSOT-25	- 40°C to +85°C
AME8840CEEVZ	ALEww	2.8V	SOT-25	- 40°C to +85°C
AME8840CEEVY	ALEww	2.8V	TSOT-25	- 40°C to +85°C

■ Ordering Information (contd.)

Part Number	Marking*	Output Voltage	Package	Operating Ambient Temperature Range
AME8840DEEV	ALFww	2.5V	SOT-25	- 40°C to +85°C
AME8840DEEVL	ALFww	2.5V	TSOT-25	- 40°C to +85°C
AME8840DEEVZ	ALFww	2.5V	SOT-25	- 40°C to +85°C
AME8840DEEVY	ALFww	2.5V	TSOT-25	- 40°C to +85°C
AME8840EEEV	ALGww	3.8V	SOT-25	- 40°C to +85°C
AME8840EEEVL	ALGww	3.8V	TSOT-25	- 40°C to +85°C
AME8840EEEVZ	ALGww	3.8V	SOT-25	- 40°C to +85°C
AME8840EEEVY	ALGww	3.8V	TSOT-25	- 40°C to +85°C
AME8840FEEV	ALHww	3.6V	SOT-25	- 40°C to +85°C
AME8840FEEVL	ALHww	3.6V	TSOT-25	- 40°C to +85°C
AME8840FEEVZ	ALHww	3.6V	SOT-25	- 40°C to +85°C
AME8840FEEVY	ALHww	3.6V	TSOT-25	- 40°C to +85°C
AME8840GEEV	ALIww	3.5V	SOT-25	- 40°C to +85°C
AME8840GEEVL	ALIww	3.5V	TSOT-25	- 40°C to +85°C
AME8840GEEVZ	ALIww	3.5V	SOT-25	- 40°C to +85°C
AME8840GEEVY	ALIww	3.5V	TSOT-25	- 40°C to +85°C
AME8840HEEV	ALJww	2.7V	SOT-25	- 40°C to +85°C
AME8840HEEVL	ALJww	2.7V	TSOT-25	- 40°C to +85°C
AME8840HEEVZ	ALJww	2.7V	SOT-25	- 40°C to +85°C
AME8840HEEVY	ALJww	2.7V	TSOT-25	- 40°C to +85°C
AME8840IEEV	ALKww	3.4V	SOT-25	- 40°C to +85°C
AME8840IEEVL	ALKww	3.4V	TSOT-25	- 40°C to +85°C
AME8840IEEVZ	ALKww	3.4V	SOT-25	- 40°C to +85°C
AME8840IEEVY	ALKww	3.4V	TSOT-25	- 40°C to +85°C
AME8840JEEV	ALLww	2.85V	SOT-25	- 40°C to +85°C
AME8840JEEVL	ALLww	2.85V	TSOT-25	- 40°C to +85°C
AME8840JEEVZ	ALLww	2.85V	SOT-25	- 40°C to +85°C
AME8840JEEVY	ALLww	2.85V	TSOT-25	- 40°C to +85°C
AME8840KEEV	ALMww	3.7V	SOT-25	- 40°C to +85°C
AME8840KEEVL	ALMww	3.7V	TSOT-25	- 40°C to +85°C
AME8840KEEVZ	ALMww	3.7V	SOT-25	- 40°C to +85°C

■ Ordering Information (contd.)

Part Number	Marking*	Output Voltage	Package	Operating Ambient Temperature Range
AME8840KEEVY	ALMww	3.7V	TSOT-25	- 40°C to +85°C
AME8840LEEV	ALNww	1.5V	SOT-25	- 40°C to +85°C
AME8840LEEVL	ALNww	1.5V	TSOT-25	- 40°C to +85°C
AME8840LEEVZ	ALNww	1.5V	SOT-25	- 40°C to +85°C
AME8840LEEVY	ALNww	1.5V	TSOT-25	- 40°C to +85°C
AME8840MEEV	ALOWw	1.8V	SOT-25	- 40°C to +85°C
AME8840MEEVL	ALOWw	1.8V	TSOT-25	- 40°C to +85°C
AME8840MEEVZ	ALOWw	1.8V	SOT-25	- 40°C to +85°C
AME8840MEEVY	ALOWw	1.8V	TSOT-25	- 40°C to +85°C
AME8840NEEV	ALPww	2.9V	SOT-25	- 40°C to +85°C
AME8840NEEVL	ALPww	2.9V	TSOT-25	- 40°C to +85°C
AME8840NEEVZ	ALPww	2.9V	SOT-25	- 40°C to +85°C
AME8840NEEVY	ALPww	2.9V	TSOT-25	- 40°C to +85°C
AME8840OEEV	ALQww	3.1V	SOT-25	- 40°C to +85°C
AME8840OEEVL	ALQww	3.1V	TSOT-25	- 40°C to +85°C
AME8840OEEVZ	ALQww	3.1V	SOT-25	- 40°C to +85°C
AME8840OEEVY	ALQww	3.1V	TSOT-25	- 40°C to +85°C
AME8840SEEV	AREww	5.0V	SOT-25	- 40°C to +85°C
AME8840SEEVL	AREww	5.0V	TSOT-25	- 40°C to +85°C
AME8840SEEVZ	AREww	5.0V	SOT-25	- 40°C to +85°C
AME8840SEEVY	AREww	5.0V	TSOT-25	- 40°C to +85°C
AME88011EEVZ	BDPww	1.3V	SOT-25	- 40°C to +85°C
AME88011EEVY	BDPww	1.3V	TSOT-25	- 40°C to +85°C
AME8801YEEVZ	BDLww	1.9V	SOT-25	- 40°C to +85°C
AME8801YEEVY	BDLww	1.9V	TSOT-25	- 40°C to +85°C
AME8801QEEVZ	APWww	4.75V	SOT-25	- 40°C to +85°C
AME8801QEEVY	APWww	4.75V	TSOT-25	- 40°C to +85°C
AME8801WEEVZ	BKMww	2.3V	SOT-25	- 40°C to +85°C
AME8801WEEVY	BKMww	2.3V	TSOT-25	- 40°C to +85°C
AME88016EEVZ	BKNww	3.45V	SOT-25	- 40°C to +85°C
AME88016EEVY	BKNww	3.45V	TSOT-25	- 40°C to +85°C

■ Absolute Maximum Ratings

Parameter	Maximum	Unit
Input Voltage	-0.3 to +8	V
EN, BYP Voltage	-0.3 to +8	V
Output Voltage	-0.3 to $V_{IN} + 0.3$	V
Output Current	$P_D / (V_{IN} - V_{OUT})$	mA
ESD Classification	B*	

Caution: Stress above the listed absolute maximum rating may cause permanent damage to the device.

* HBM B:2000V~3999V

■ Recommended Operating Conditions

Parameter	Symbol	Rating	Unit
Ambient Temperature Range	T_A	- 40 to +85	°C
Junction Temperature Range	T_J	- 40 to +125	°C
Storage Temperature Range	T_{STG}	- 65 to +150	°C

■ Thermal Information

Parameter	Package	Die Attach	Symbol	Maximum	Unit
Thermal Resistance * (Junction to Case)	SOT-25 TSOT-25	Conductive Epoxy	θ_{JC}	81	°C / W
	SOT-26 TSOT-26	Non-Conductive Epoxy		140	
Thermal Resistance (Junction to Ambient)	SOT-25 TSOT-25	Conductive Epoxy	θ_{JA}	260	
	SOT-26 TSOT-26	Non-Conductive Epoxy		280	
Internal Power Dissipation	SOT-25 TSOT-25	Conductive Epoxy	P_D	400	mW
	SOT-26 TSOT-26	Non-Conductive Epoxy		400	
Maximum Junction Temperature				150	°C
Solder Iron (10Sec)**				350	°C

* Measure θ_{JC} on center of molding compound if IC has no tab.

** MIL-STD-202G 210F

■ Electrical Specifications

TA = 25°C unless otherwise noted

Parameter	Symbol	Test Condition	Min	Typ	Max	Units	
Input Voltage	V_{IN}		Note 1		7	V	
Output Voltage Accuracy	V_O	$I_O=1mA$	-1.5		1.5	%	
		$I_O=300mA$	-2.5		2.5		
Dropout Voltage	$V_{DROPOUT}$	$I_O=300mA$ $V_O=V_{O(NOM)} - 2.0\%$	$1.2V \leq V_{O(NOM)} \leq 2.0V$			1300	mV
			$2.0V < V_{O(NOM)} \leq 2.4V$			700	
			$2.4V < V_{O(NOM)} \leq 2.8V$			400	
			$2.8V < V_{O(NOM)}$			300	
Output Current	I_O	$V_O > 1.2V$	300			mA	
Current Limit	I_{LIM}	$V_O > 1.2V$	300	450		mA	
Short Circuit Current, Note2	I_{SC}	$V_O < 0.8V$		150	300	mA	
Quiescent Current	I_Q	$I_O=0mA$		30	50	μA	
Ground Pin Current	I_{GND}	$I_O=1mA$ to 300mA		35		μA	
Line Regulation	REG_{LINE}	$I_O=1mA$ $V_{IN}=V_O+1$ to V_O+2	$1.2V \leq V_O \leq 1.4V$	-0.2		0.2	%
			$1.4V < V_O \leq 2.0V$	-0.15		0.15	
			$2.0V < V_O < 4.0V$	-0.1	0.02	0.1	
			$4.0V \leq V_O$	-0.4	0.2	0.4	
Load Regulation	REG_{LOAD}	$I_O=1mA$ to 300mA	-1	0.2	1	%	
Over Temperature Shutdown	OTS			150		$^{\circ}C$	
Over Temperature Hysteresis	OTH			30		$^{\circ}C$	
V_O Temperature Coefficient	TC			30		ppm/ $^{\circ}C$	
Power Supply Rejection	PSRR	$I_O=100mA$ $C_O=2.2\mu F$	$f=100Hz$			60	dB
			$f=1kHz$			50	
			$f=10kHz$			20	
Output Voltage Noise	eN	$f=10Hz$ to 100kHz $I_O=10mA$				30	μV_{rms}
EN Input Threshold	V_{EH}	$V_{IN}=2.7V$ to 7V	2.0		V_{in}	V	
	V_{EL}	$V_{IN}=2.7V$ to 7V	0		0.4	V	
EN Input Bias Current	I_{EH}	$V_{EN}=V_{IN}$, $V_{IN}=2.7V$ to 7V			0.1	μA	
	I_{EL}	$V_{EN}=0V$, $V_{IN}=2.7V$ to 7V			0.5	μA	
Shutdown Supply Current	I_{SD}	$V_{IN}=5V$, $V_O=0V$, $V_{EN} < V_{EL}$		0.5	1	μA	
Shutdown Output Voltage	$V_{O,SD}$	$I_O=0.4mA$, $V_{EN} < V_{EL}$	0		0.4	V	

 Note1: $V_{IN(MIN)} = V_{OUT} + V_{DROPOUT}$

Note2: To prevent the Short Circuit Current protection feature from being prematurely activated, the input voltage must be applied before a current source load is applied.

■ Detailed Description

The AME8801/8812/8840 family of CMOS regulators contain a PMOS pass transistor, voltage reference, error amplifier, over-current protection, and thermal shutdown.

The P-channel pass transistor receives data from the error amplifier, over-current shutdown, and thermal protection circuits. During normal operation, the error amplifier compares the output voltage to a precision reference. Over-current and Thermal shutdown circuits become active when the junction temperature exceeds 150°C, or the current exceeds 300mA. During thermal shutdown, the output voltage remains low. Normal operation is restored when the junction temperature drops below 120°C.

The AME8801/8812/8840 switches from voltage mode to current mode when the load exceeds the rated output current. This prevents over-stress. The AME8801/8812/8840 also incorporates current foldback to reduce power dissipation when the output is short circuited. This feature becomes active when the output drops below 0.8volts, and reduces the current flow by 65%. Full current is restored when the voltage exceeds 0.8 volts.

■ External Capacitors

The AME8801/8812/8840 is stable with an output capacitor to ground of 2.2 μ F or greater. Ceramic capacitors have the lowest ESR, and will offer the best AC performance. Conversely, Aluminum Electrolytic capacitors exhibit the highest ESR, resulting in the poorest AC response. Unfortunately, large value ceramic capacitors are comparatively expensive. One option is to parallel a 0.1 μ F ceramic capacitor with a 10 μ F Aluminum Electrolytic. The benefit is low ESR, high capacitance, and low overall cost.

A second capacitor is recommended between the input and ground to stabilize V_{in} . The input capacitor should be at least 0.1 μ F to have a beneficial effect.

A third capacitor can be connected between the BY-PASS pin and GND. This capacitor can be a low cost Polyester Film variety between the value of 0.001 ~ 0.01 μ F. A larger capacitor improves the AC ripple rejection, but also makes the output come up slowly. This "Soft" turn-on is desirable in some applications to limit turn-on surges.

All capacitors should be placed in close proximity to the pins. A "Quiet" ground termination is desirable. This can be achieved with a "Star" connection.

■ Enable

The Enable pin normally floats high. When actively, pulled low, the PMOS pass transistor shuts off, and all internal circuits are powered down. In this state, the quiescent current is less than 1 μ A. This pin behaves much like an electronic switch.

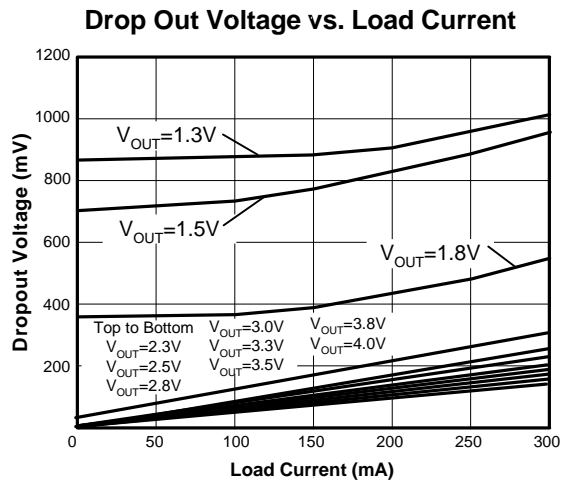
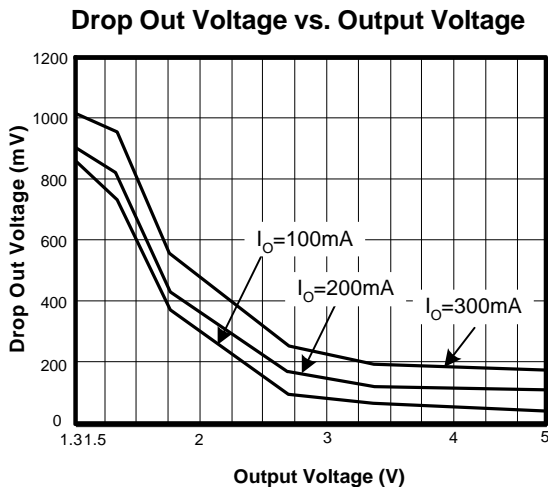
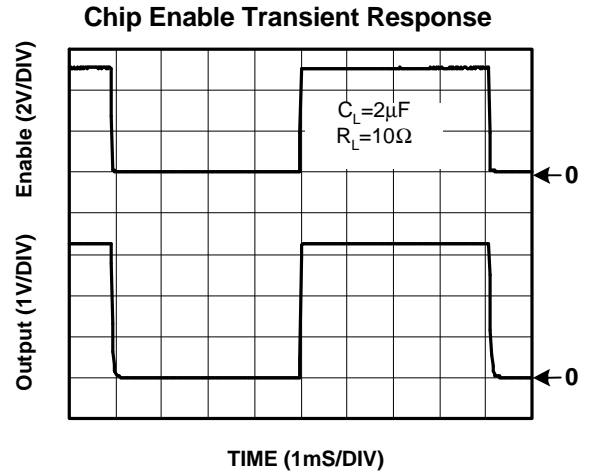
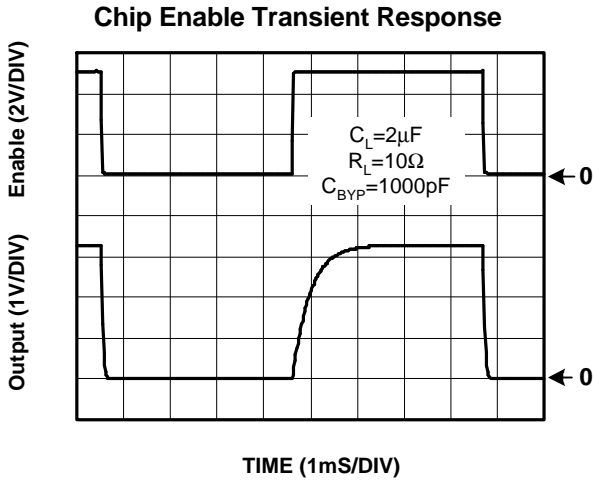
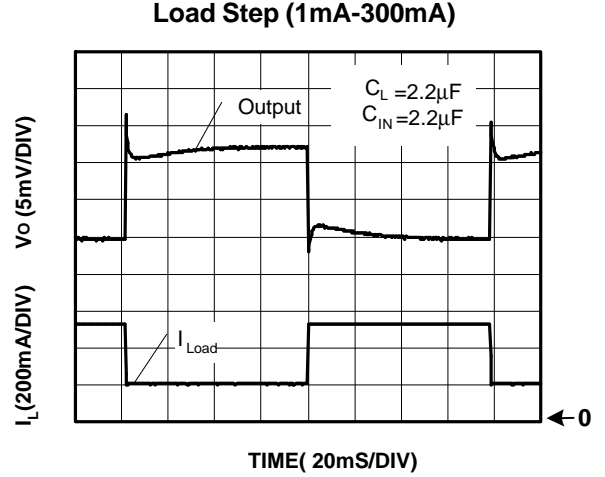
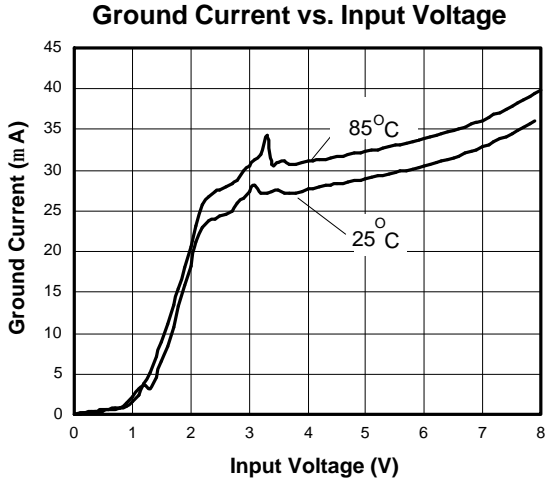

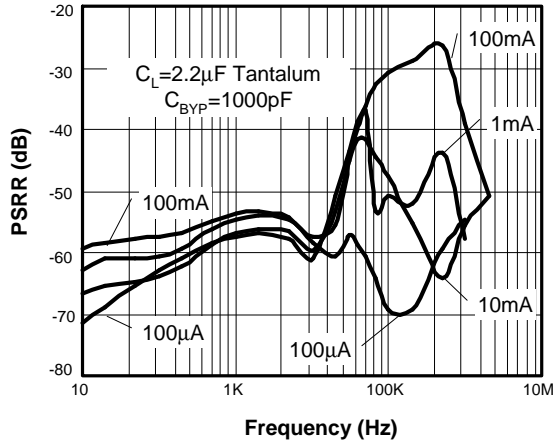
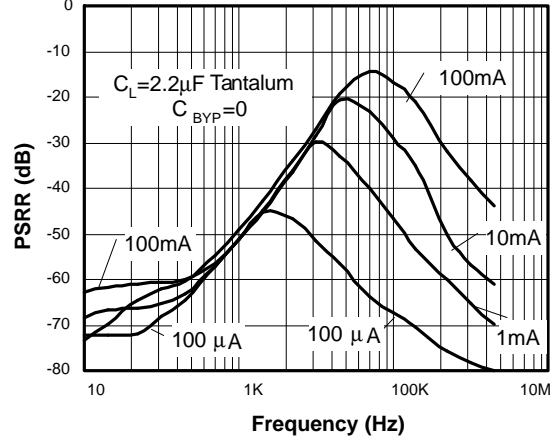
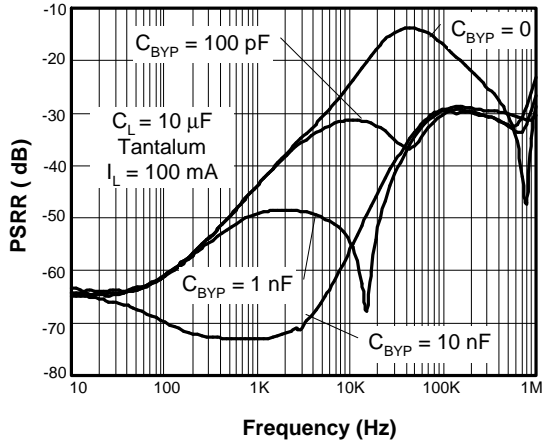
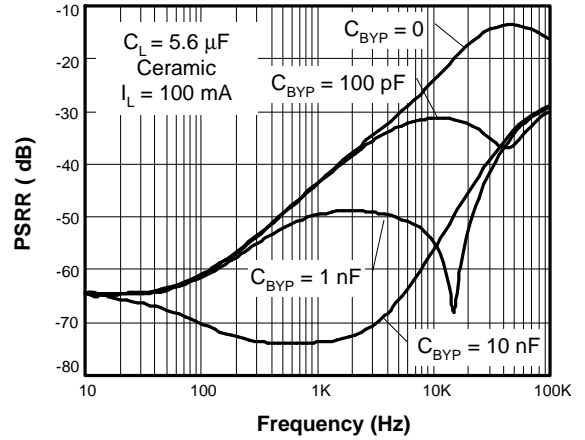
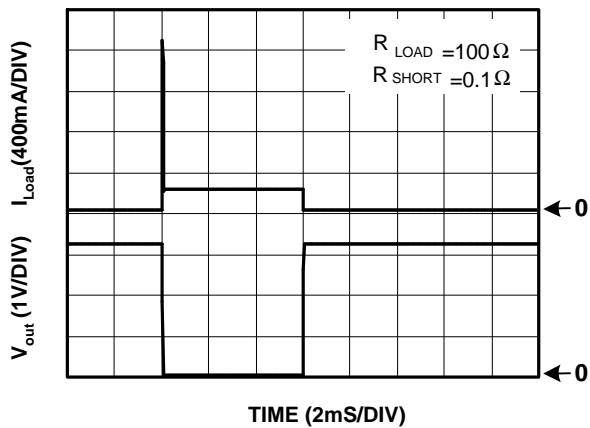
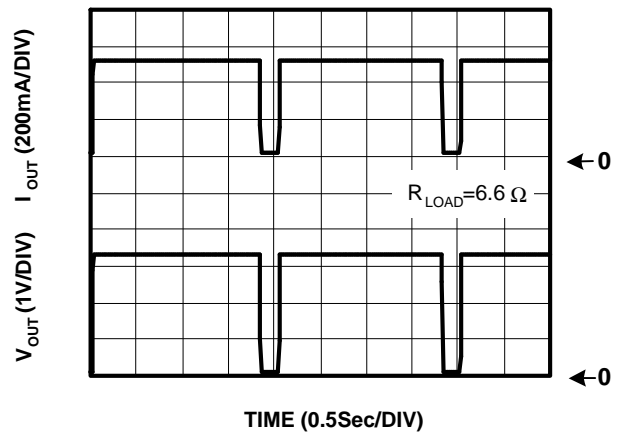
Power Supply Rejection Ratio

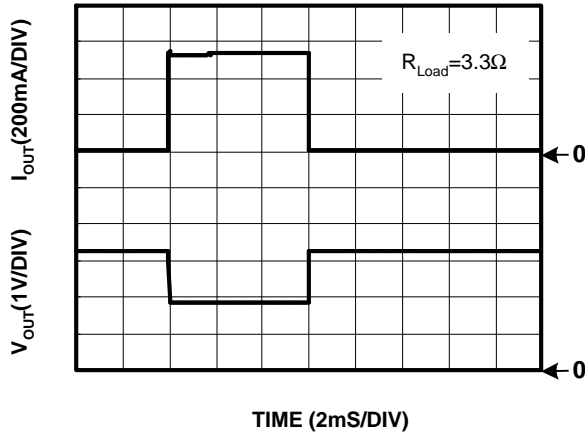
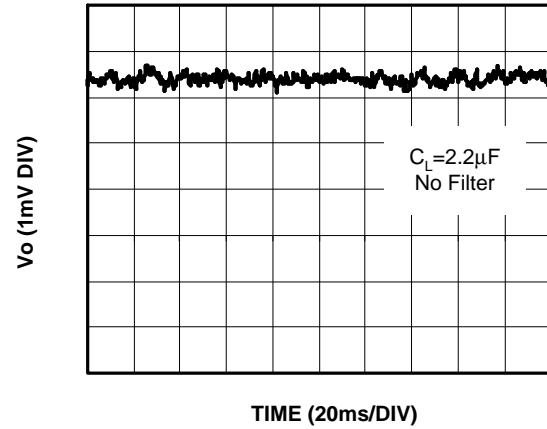
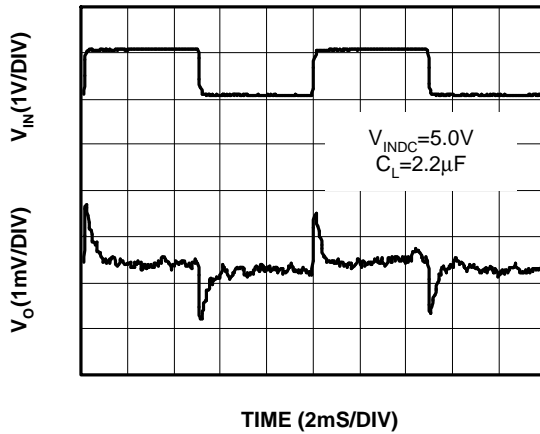
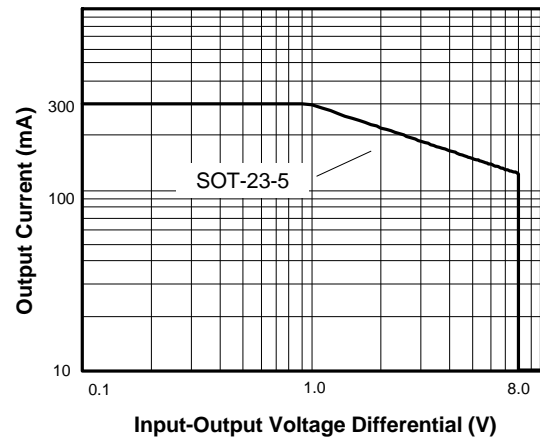
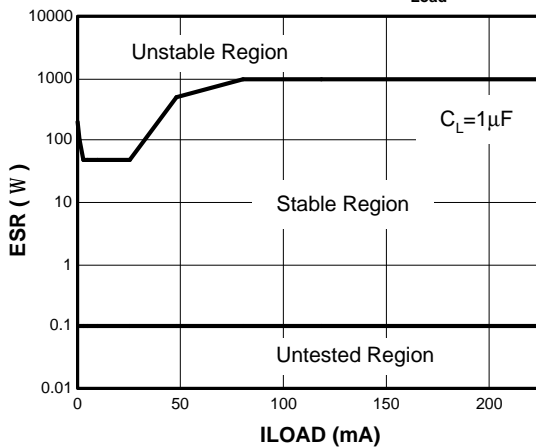
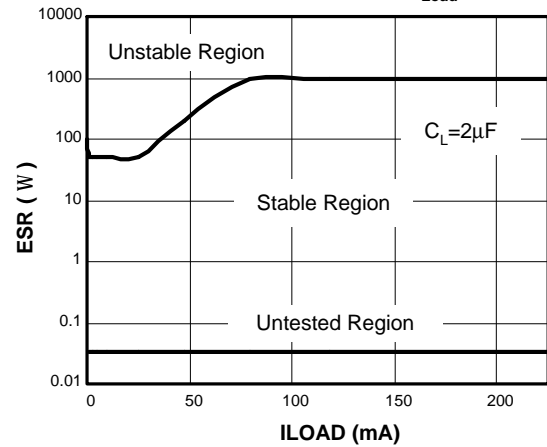
Power Supply Rejection Ratio

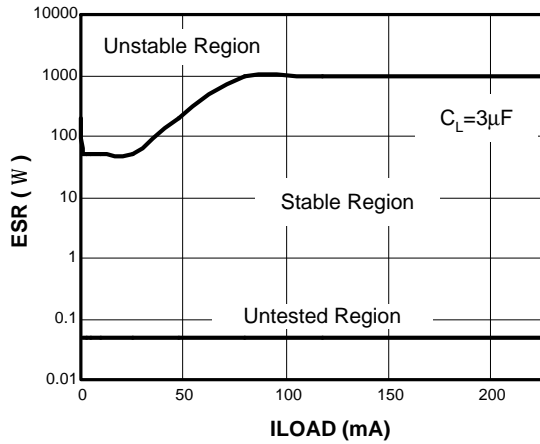
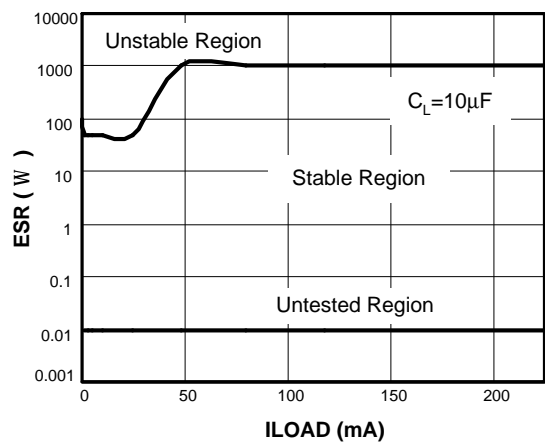
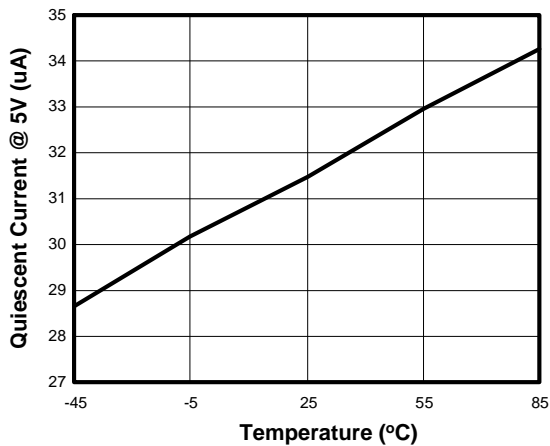
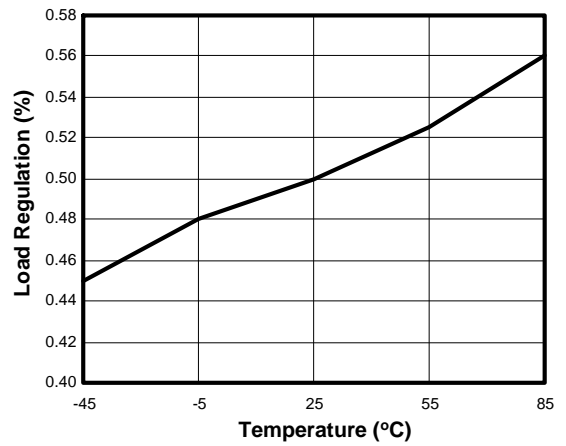
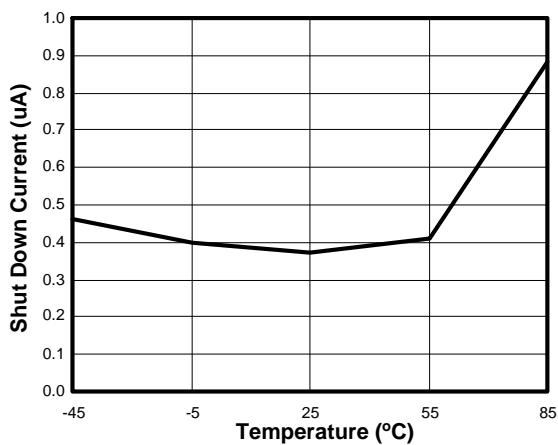
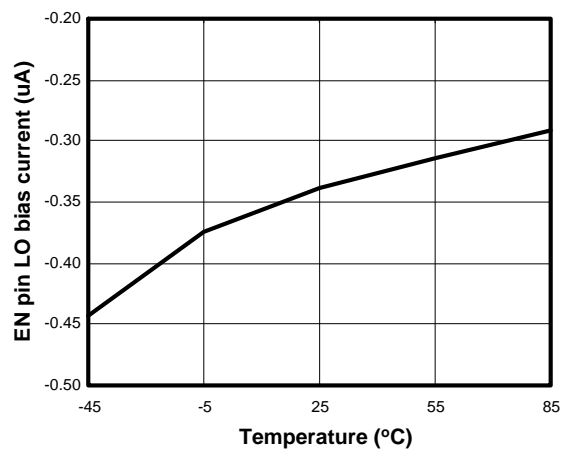
Power Supply Rejection Ratio

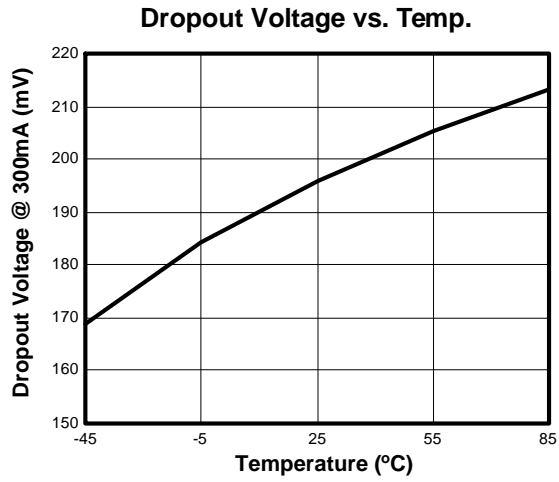
Power Supply Rejection Ratio

Short Circuit Response

Overtemperature Shutdown

Current Limit Response

Noise Measurement

Line Transient Response

Safe Operating Area

Stability vs. ESR vs. I_{Load}

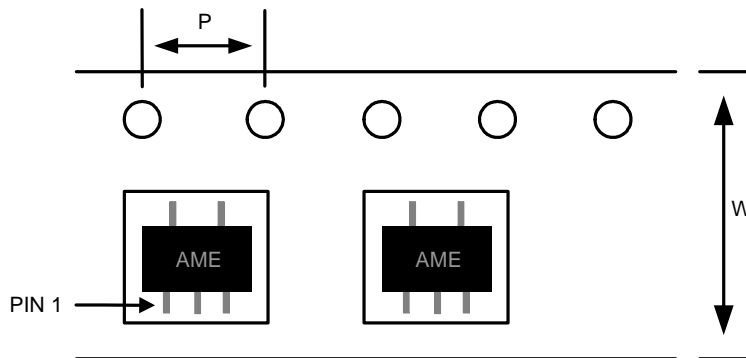
Stability vs. ESR vs. I_{Load}

Stability vs. ESR vs. I_{Load}

Stability vs. ESR vs. I_{Load}

Quiescent Current vs. Temp.

Load Regulation vs. Temp.

Shut Down Current vs. Temp.

EN pin LO bias Current vs. Temp.



■ Date Code Rule

Marking			Date Code		Year
A	A	A	W	W	xxx0
A	A	A	W	<u>W</u>	xxx1
A	A	A	<u>W</u>	W	xxx2
A	A	A	<u>W</u>	<u>W</u>	xxx3
A	A	<u>A</u>	W	W	xxx4
A	A	<u>A</u>	W	<u>W</u>	xxx5
A	A	<u>A</u>	<u>W</u>	W	xxx6
A	A	<u>A</u>	<u>W</u>	<u>W</u>	xxx7
A	<u>A</u>	A	W	W	xxx8
A	<u>A</u>	A	W	<u>W</u>	xxx9

■ Tape and Reel Dimension
SOT-25

Carrier Tape, Number of Components Per Reel and Reel Size

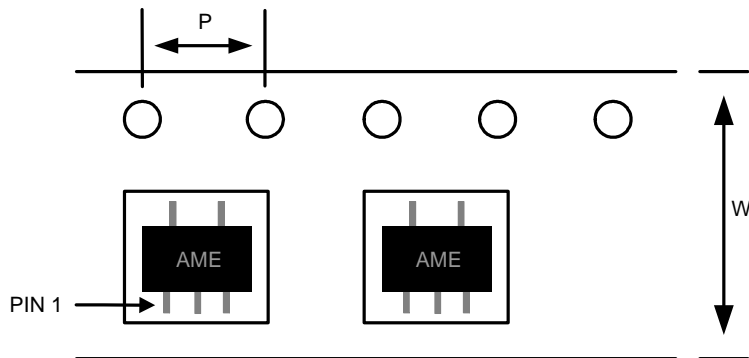
Package	Carrier Width (W)	Pitch (P)	Part Per Full Reel	Reel Size
SOT-25	8.0±0.1 mm	4.0±0.1 mm	3000pcs	180±1 mm

■ Tape and Reel Dimension
TSOT-25

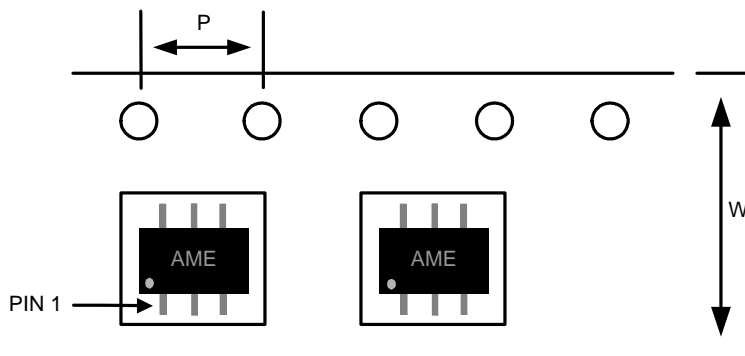
Carrier Tape, Number of Components Per Reel and Reel Size

Package	Carrier Width (W)	Pitch (P)	Part Per Full Reel	Reel Size
TSOT-25	8.0±0.1 mm	4.0±0.1 mm	3000pcs	180±1 mm

SOT-26

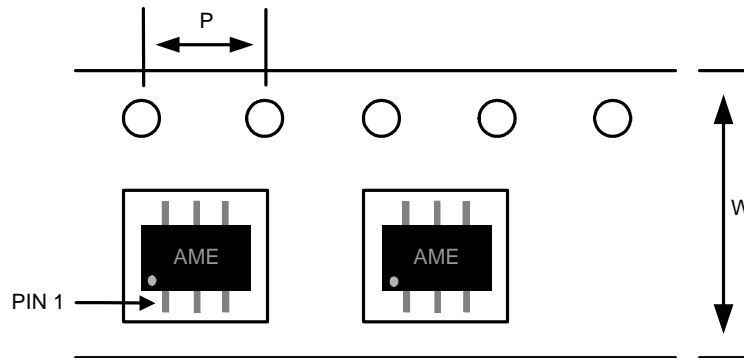
Carrier Tape, Number of Components Per Reel and Reel Size

Package	Carrier Width (W)	Pitch (P)	Part Per Full Reel	Reel Size
SOT-26	8.0±0.1 mm	4.0±0.1 mm	3000pcs	180±1 mm

■ Tape and Reel Dimension
TSOT-26

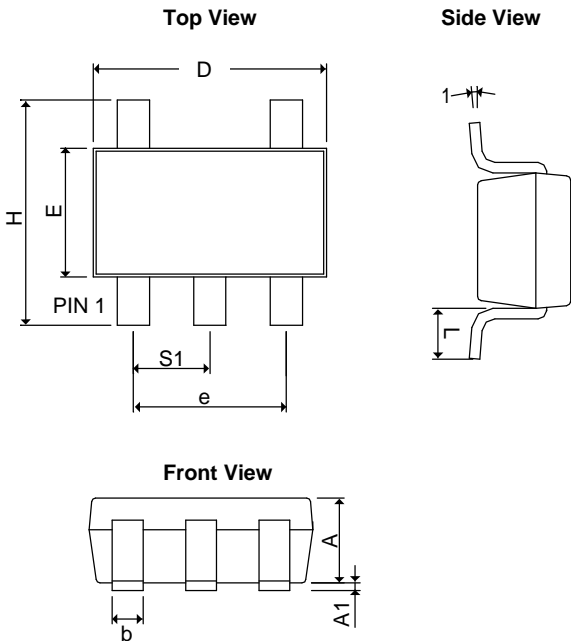
Carrier Tape, Number of Components Per Reel and Reel Size

Package	Carrier Width (W)	Pitch (P)	Part Per Full Reel	Reel Size
TSOT-26	8.0±0.1 mm	4.0±0.1 mm	3000pcs	180±1 mm

■ Package Dimension
SOT-25

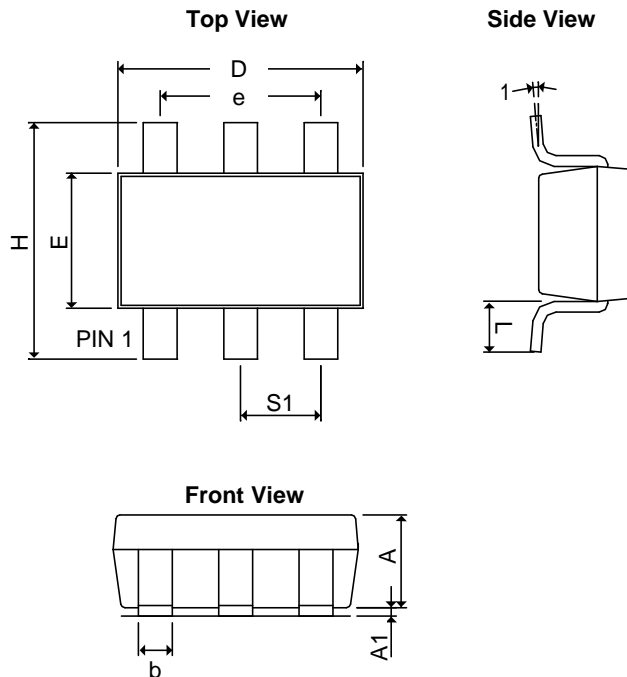
SYMBOLS	MILLIMETERS		INCHES	
	MIN	MAX	MIN	MAX
A	1.20REF		0.0472REF	
A ₁	0.00	0.15	0.0000	0.0059
b	0.30	0.55	0.0118	0.0217
D	2.70	3.10	0.1063	0.1220
E	1.40	1.80	0.0551	0.0709
e	1.90 BSC		0.07480 BSC	
H	2.60	3.00	0.10236	0.11811
L	0.37BSC		0.0146BSC	
q1	0°	10°	0°	10°
S ₁	0.95BSC		0.0374BSC	

SOT-26

SYMBOLS	MILLIMETERS		INCHES	
	MIN	MAX	MIN	MAX
A	1.20REF		0.0472REF	
A ₁	0.00	0.15	0.0000	0.0059
b	0.30	0.55	0.0118	0.0217
D	2.70	3.10	0.1063	0.1220
E	1.40	1.80	0.0551	0.0709
e	1.90 BSC		0.0748 BSC	
H	2.60	3.00	0.10236	0.11811
L	0.37REF		0.0146REF	
q1	0°	10°	0°	10°
S ₁	0.95REF		0.0374REF	

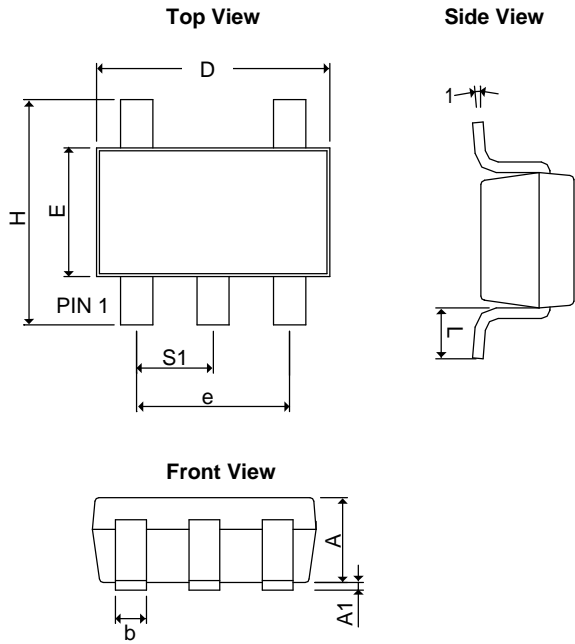
■ Package Dimension
TSOT-25

SYMBOLS	MILLIMETERS		INCHES	
	MIN	MAX	MIN	MAX
A+A₁	0.90	1.25	0.0354	0.0492
b	0.30	0.50	0.0118	0.0197
D	2.70	3.10	0.1063	0.1220
E	1.40	1.80	0.0551	0.0709
e	1.90 BSC		0.07480 BSC	
H	2.40	3.00	0.09449	0.11811
L	0.35BSC		0.0138BSC	
q1	0°	10°	0°	10°
S₁	0.95BSC		0.0374BSC	

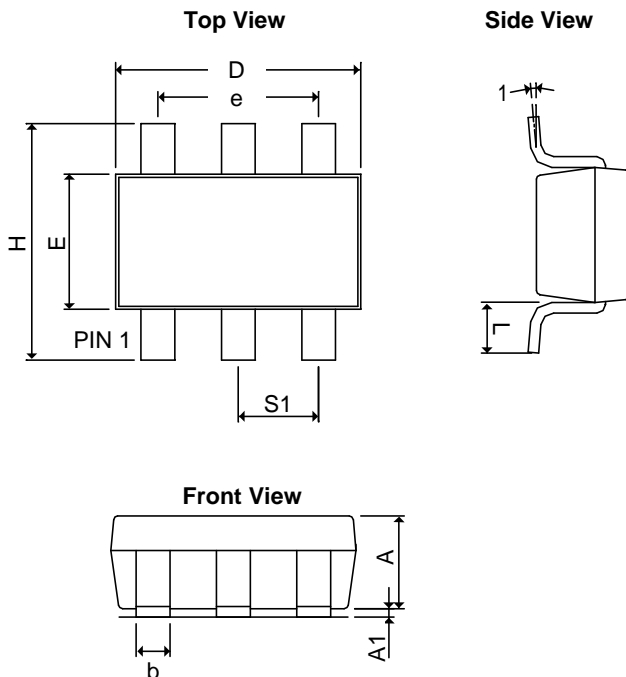
TSOT-26

SYMBOLS	MILLIMETERS		INCHES	
	MIN	MAX	MIN	MAX
A+A₁	0.90	1.25	0.0354	0.0492
b	0.30	0.50	0.0118	0.0197
D	2.70	3.10	0.1063	0.1220
E	1.40	1.80	0.0551	0.0709
e	1.90 BSC		0.07480 BSC	
H	2.40	3.00	0.09449	0.11811
L	0.35BSC		0.0138BSC	
q1	0°	10°	0°	10°
S₁	0.95BSC		0.0374BSC	



www.ame.com.tw
E-Mail: sales@ame.com.tw

Life Support Policy:

These products of AME, Inc. are not authorized for use as critical components in life-support devices or systems, without the express written approval of the president of AME, Inc.

AME, Inc. reserves the right to make changes in the circuitry and specifications of its devices and advises its customers to obtain the latest version of relevant information.

© AME, Inc. , November 2008

Document: 2006/2095-DS8801/8812/8840-S.02

Corporate Headquarter
AME, Inc.

2F, 302 Rui-Guang Road, Nei-Hu District

Taipei 114, Taiwan, R.O.C.

Tel: 886 2 2627-8687

Fax: 886 2 2659-2989