

DESIGNED & DIMENSIONED
IN MILLIMETERS [INCHES]

DO NOT
SCALE FROM
THIS PRINT

SMA-P-C-X-ST-CA5

GENDER
-P: PLUG

TYPE
-C: CABLE

TERMINATION
-CA5: CABLE
(.063" SEMI-FLEXIBLE CABLE)

ORIENTATION
-ST: STRAIGHT

PLATING SPECIFICATION
-H: HEAVY GOLD (SEE NOTES 7 & 8)
(SMA-PIN-007-H)
(SUB-SMA-P-C-F-ST-CA5)
(SMA-INS-011)

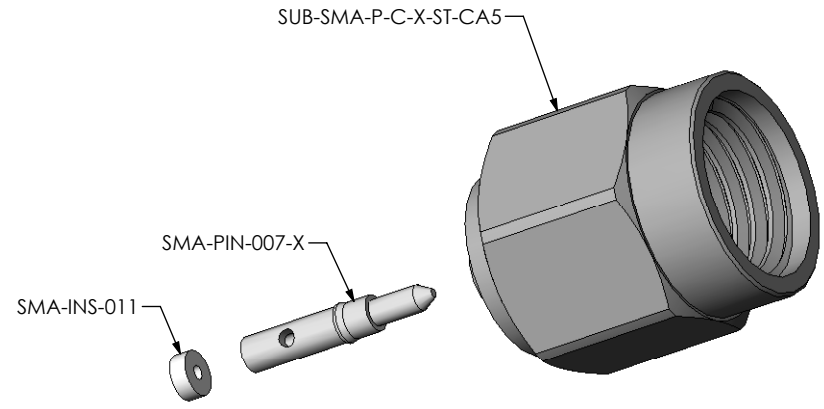
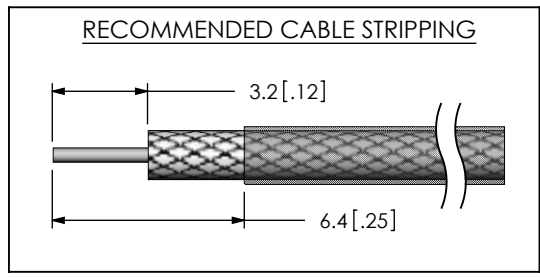



FIG.1
SMA-P-C-X-ST-CA5 SHOWN



- NOTES:
- Ⓢ REPRESENTS A CRITICAL DIMENSION.
 - CENTER CONTACT PUSHOUT FORCE: 26.69 N [6 LB] MIN.
 - SEE SHEET 3 FOR TERMINATION INFORMATION.
 - NOTE DELETED.
 - PRODUCT TO BE PACKAGED PER PACKAGING STANDARD CO-HD-WI-3040-M.
 - RoHS COMPLIANT.
 - PLATING: -F: .000003" MIN. GOLD OVER .000050" MIN. NICKEL.
-H: .000030" MIN. GOLD OVER .000050" MIN. NICKEL.
 - ASSEMBLY PLATING DESIGNATIONS:
-H: (CENTER CONTACT)-H
(OUTER CONTACT) -F

THIS PRODUCT MANUFACTURED WITH LEAD-FREE PROCESSING

F:\DWG\MISC\MKTG\SMA-P-C-X-ST-CA5-MKT.SLDDRW

<p>UNLESS OTHERWISE SPECIFIED, DIMENSIONS ARE IN MILLIMETERS [INCHES]. TOLERANCES ARE:</p> <p>DECIMALS ANGLES</p> <p>.X: ±0.3 [.01] 2°</p> <p>.XX: ±0.13 [.005]</p> <p>.XXX: ±0.051 [.0020]</p>	<p>PROPRIETARY NOTE</p> <p>THIS DOCUMENT CONTAINS INFORMATION CONFIDENTIAL AND PROPRIETARY TO SAMTEC, INC. AND SHALL NOT BE REPRODUCED OR TRANSFERRED TO OTHER DOCUMENTS OR DISCLOSED TO OTHERS OR USED FOR ANY PURPOSE OTHER THAN THAT WHICH IT WAS OBTAINED WITHOUT THE EXPRESSED WRITTEN CONSENT OF SAMTEC, INC.</p>	 <p>520 PARK EAST BLVD. NEW ALBANY, IN 47150 PHONE: 812-944-6733 FAX: 812-948-5047 e-Mail info@SAMTEC.com code 55322</p>
<p>MATERIAL: DO NOT SCALE DRAWING SHEET SCALE: 4:1</p> <p>CABLE BODY, COUPLING NUT, C-RING: BRASS CONTACT: BRASS DIELECTRIC: PTFE GASKET: SILICONE</p>	<p>DESCRIPTION: SMA STRAIGHT CABLE PLUG, 25 AWG CABLE - 50 OHM</p> <p>DWG. NO. SMA-P-C-X-ST-CA5</p> <p>BY: R MUSSER 01/22/2008 SHEET 1 OF 3</p>	

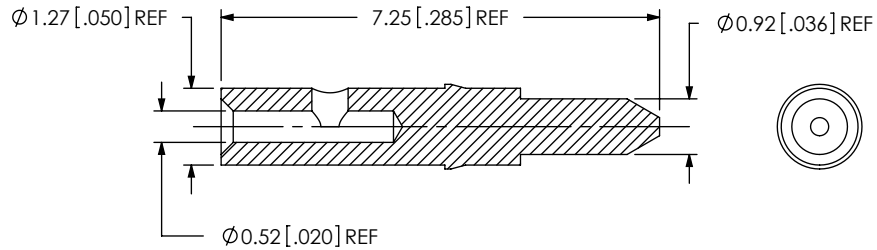

SAMTEC PART NUMBER	ITEM
SMA-PIN-007-X	PIN

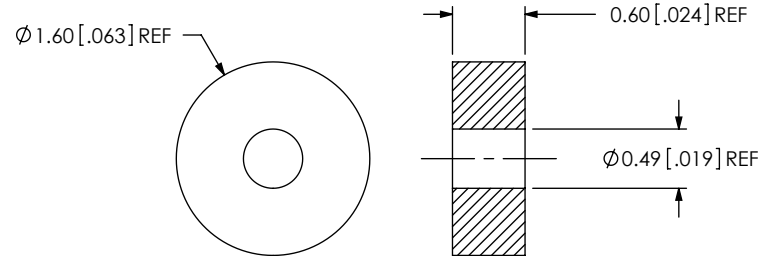

SAMTEC PART NUMBER	ITEM
SMA-INS-011	INSULATOR

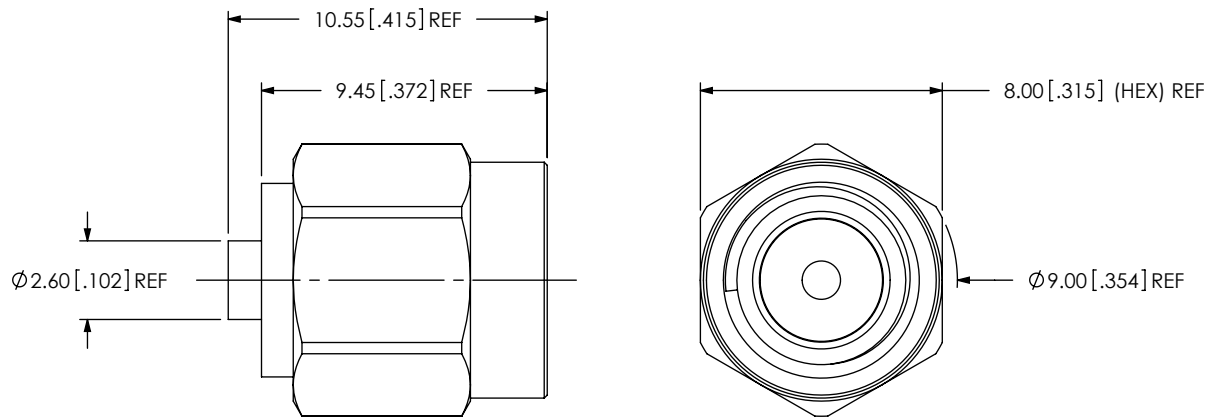

SAMTEC PART NUMBER	ITEM
SUB-SMA-P-C-X-ST-CA5	SUB ASSEMBLY

F:\DWG\MISC\MKTG\SMA-P-C-X-ST-CA5-MKT.SLDDRW

PROPRIETARY NOTE

THIS DOCUMENT CONTAINS INFORMATION CONFIDENTIAL AND PROPRIETARY TO SAMTEC, INC. AND SHALL NOT BE REPRODUCED OR TRANSFERRED TO OTHER DOCUMENTS OR DISCLOSED TO OTHERS OR USED FOR ANY PURPOSE OTHER THAN THAT WHICH IT WAS OBTAINED WITHOUT THE EXPRESSED WRITTEN CONSENT OF SAMTEC, INC.

DO NOT SCALE DRAWING

SHEET SCALE: 4:1



520 PARK EAST BLVD, NEW ALBANY, IN 47150
 PHONE: 812-944-6733 FAX: 812-948-5047
 e-Mail: info@SAMTEC.com code 55322

DESCRIPTION:
 SMA STRAIGHT CABLE PLUG, 25 AWG CABLE - 50 OHM

DWG. NO.
SMA-P-C-X-ST-CA5

BY: R MUSSER 01/22/2008 SHEET 2 OF 3

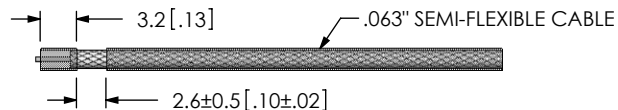

STRIP AND LOCATE JACKET



TIN INNER AND OUTER CONDUCTOR
REMOVE CUT JACKET

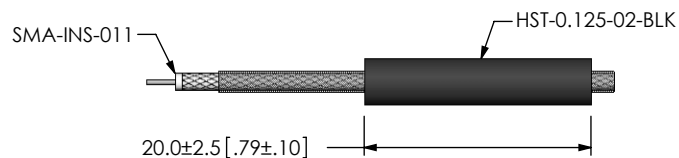

ADD INSULATOR AND HEAT SHRINK TUBE

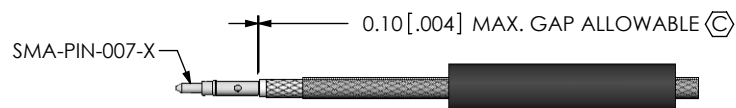

SOLDER SIGNAL PIN

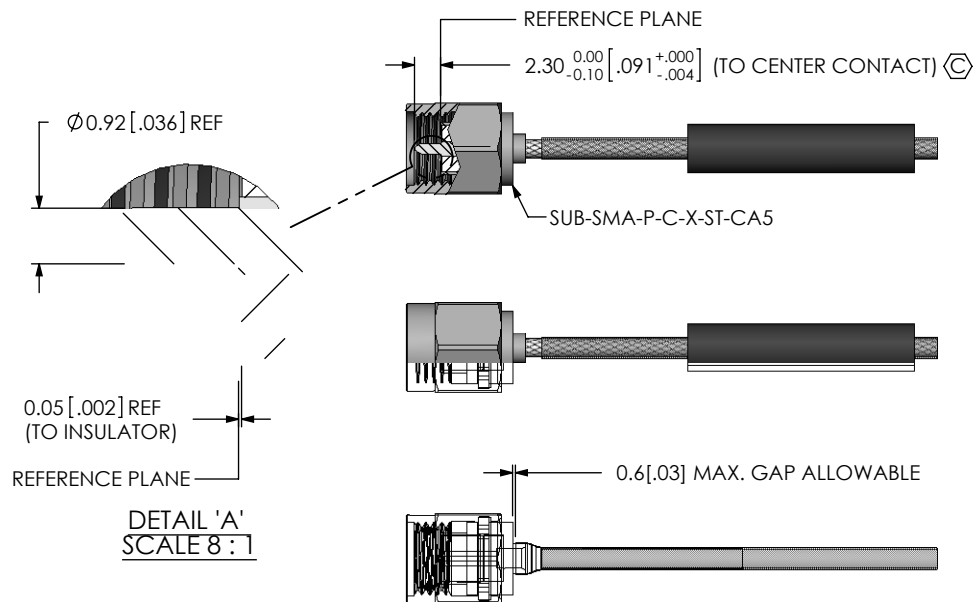

ADD SUB-SMA-P-C-X-ST-CA5

SOLDER SUB ASSEMBLY

APPLY HEAT SHRINK TUBING

F:\DWG\MISC\MKTG\SMA-P-C-X-ST-CA5-MKT.SLDDRW

PROPRIETARY NOTE

THIS DOCUMENT CONTAINS INFORMATION CONFIDENTIAL AND PROPRIETARY TO SAMTEC, INC. AND SHALL NOT BE REPRODUCED OR TRANSFERRED TO OTHER DOCUMENTS OR DISCLOSED TO OTHERS OR USED FOR ANY PURPOSE OTHER THAN THAT WHICH IT WAS OBTAINED WITHOUT THE EXPRESSED WRITTEN CONSENT OF SAMTEC, INC.

DO NOT SCALE DRAWING

SHEET SCALE: 1.5:1



520 PARK EAST BLVD, NEW ALBANY, IN 47150
 PHONE: 812-944-6733 FAX: 812-948-5047
 e-Mail: info@SAMTEC.com code 55322

DESCRIPTION:
 SMA STRAIGHT CABLE PLUG, 25 AWG CABLE - 50 OHM

DWG. NO.
SMA-P-C-X-ST-CA5

BY: R MUSSER 01/22/2008 SHEET 3 OF 3