

# High Efficiency Transmitter Controller for Wireless Power Systems

## DESCRIPTION

The TS80000 is a power transmitter communications and control unit for wireless charging applications. The TS80000 can support power outputs up to 40W+, and supports Qi® compliant and proprietary applications. The TS80000 can be configured to drive single or multi-coil applications, in half and full-bridge systems.

The TS80000 performs the necessary decode of packets from the secondary side device and adjusts the control accordingly. An integrated PID filter provides the necessary compensation for the loop for high-precision control of duty cycle and frequency.

## APPLICATIONS

- Qi® compliant and non-compliant wireless chargers for:
  - Cell Phones and Smartphones
  - GPS Devices
  - Digital Cameras
  - Tablets and eReaders
  - Portable Lighting
- Automotive chargers
  - OEM in-cabin chargers
  - Charging accessories

## FEATURES

- Supports Qi® and proprietary charging applications
- Power outputs up to 40W+
- Support for single and multi-coil applications
- Support for half and full-bridge power sections
- Support for fixed frequency, variable frequency and variable duty cycle architectures
- Integrated controller and FLASH for communications and control
- High precision data converters
- Precise control of bridge duty cycle and frequency
- Low external component count
- Available in 36 pin 6x6 QFN

## SPECIFICATIONS

- 32-bit CPU Core, 72 MHz
- 64kBytes Flash, 20kBytes SRAM
- Two 12-bit, 1µs A/D converters (up to 16 channels)
- 7 channel DMA controller
- Three 16-bit timers, each with up to 4 IC/OC/PWM or pulse counter and quadrature (incremental) encoder input
- Dual 16-bit PWM timers with dead-time generation
- 7 configurable analog general purpose IOs
- Two status LED outputs
- I2C interface
- USB interface
- JTAG interface

## TYPICAL APPLICATION

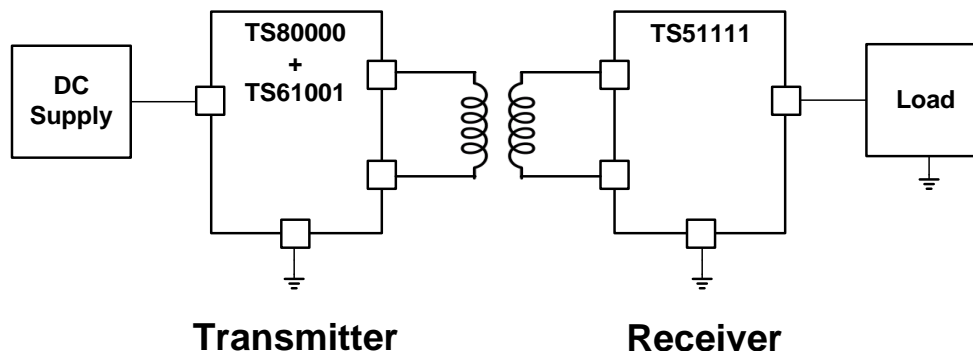

## PINOUT

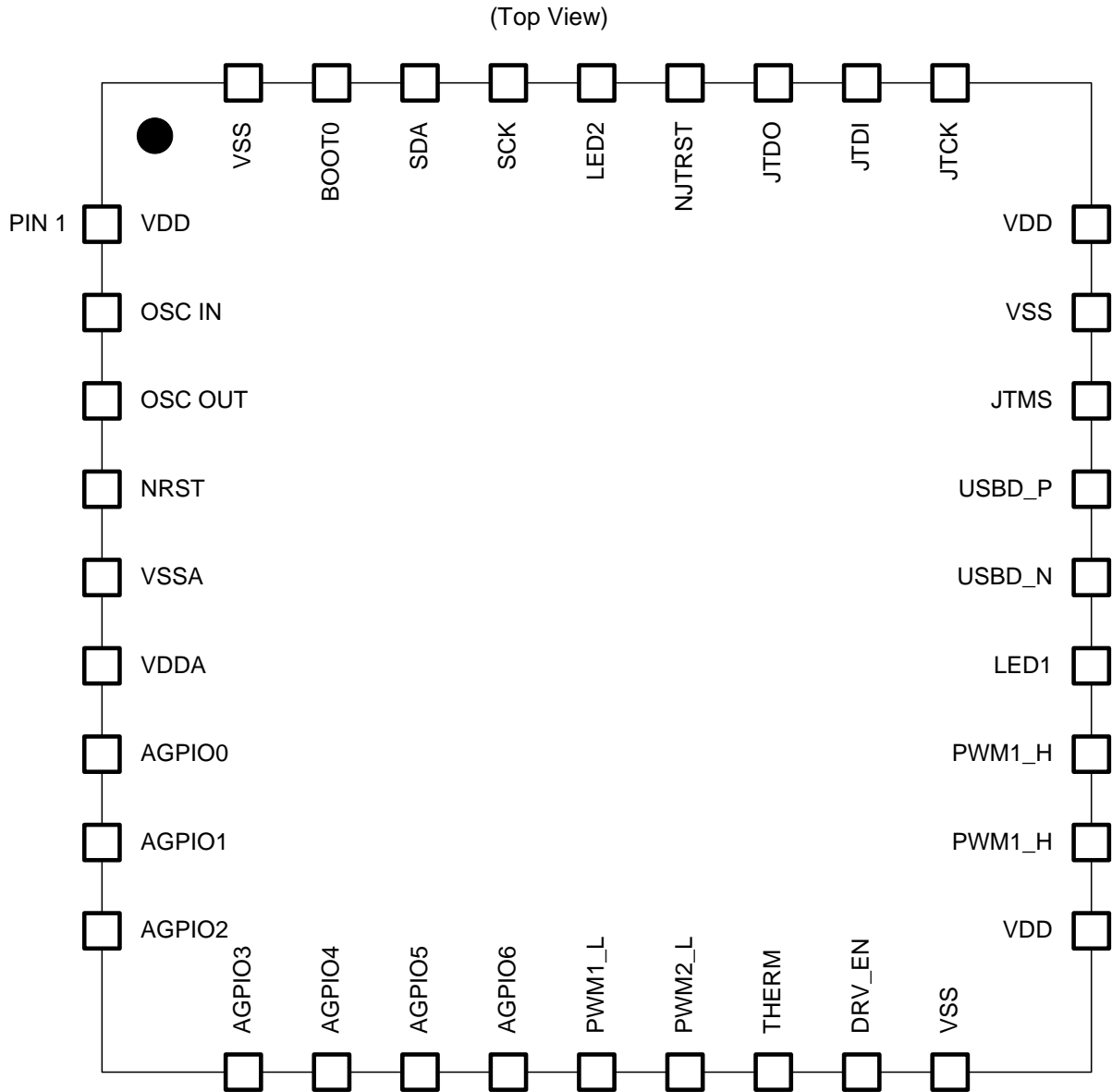

## PIN DESCRIPTION

QFN Pin #	Pin Symbol	Function	Description
1	VDD	Input power	Input power supply
2	OSC_IN	Oscillator input	Oscillator input
3	OSC_OUT	Oscillator output	Oscillator output
4	NRST	Reset	Reset input
5	VSSA	Analog GND	Analog GND
6	VDDA	Analog power	Analog power supply
7 - 13	AGPIO<0:6>	Analog GPIO	Analog GPIO <0:6>
14	PWM1_L	PWM	PWM1 low-side control
15	PWM2_L	PWM	PWM2 low-side control
16	THERM	Thermistor	Thermistor input
17	DRV_EN	Drive enable	FET driver enable
18	VSS	Power GND	Power GND
19	VDD	Input power	Input power supply
20	PWM1_H	PWM	PWM1 high-side control
21	PWM2_H	PWM	PWM2 high-side control
22	LED1	LED output	Charging LED control
23	USB_D_N	USB data	USB data input (D-)
24	USB_D_P	USB data	USB data input (D+)
25	JTMS	JTAG	JTAG state machine control
26	VSS	Power GND	Power GND
27	VDD	Input power	Input power supply
28	JTCK	JTAG	JTAG clock
29	JTDI	JTAG	JTAG data input
30	JTDO	JTAG	JTAG data output
31	NJTRST	JTAG	JTAG reset
32	LED2	LED output	Error LED control
33	SCK	I2C Clock	I2C clock
34	SDA	I2C Data	I2C data
35	BOOT0	Proprietary	Proprietary input (GND in normal operation)
36	VSS	Power GND	Power GND

# APPLICATION SCHEMATIC

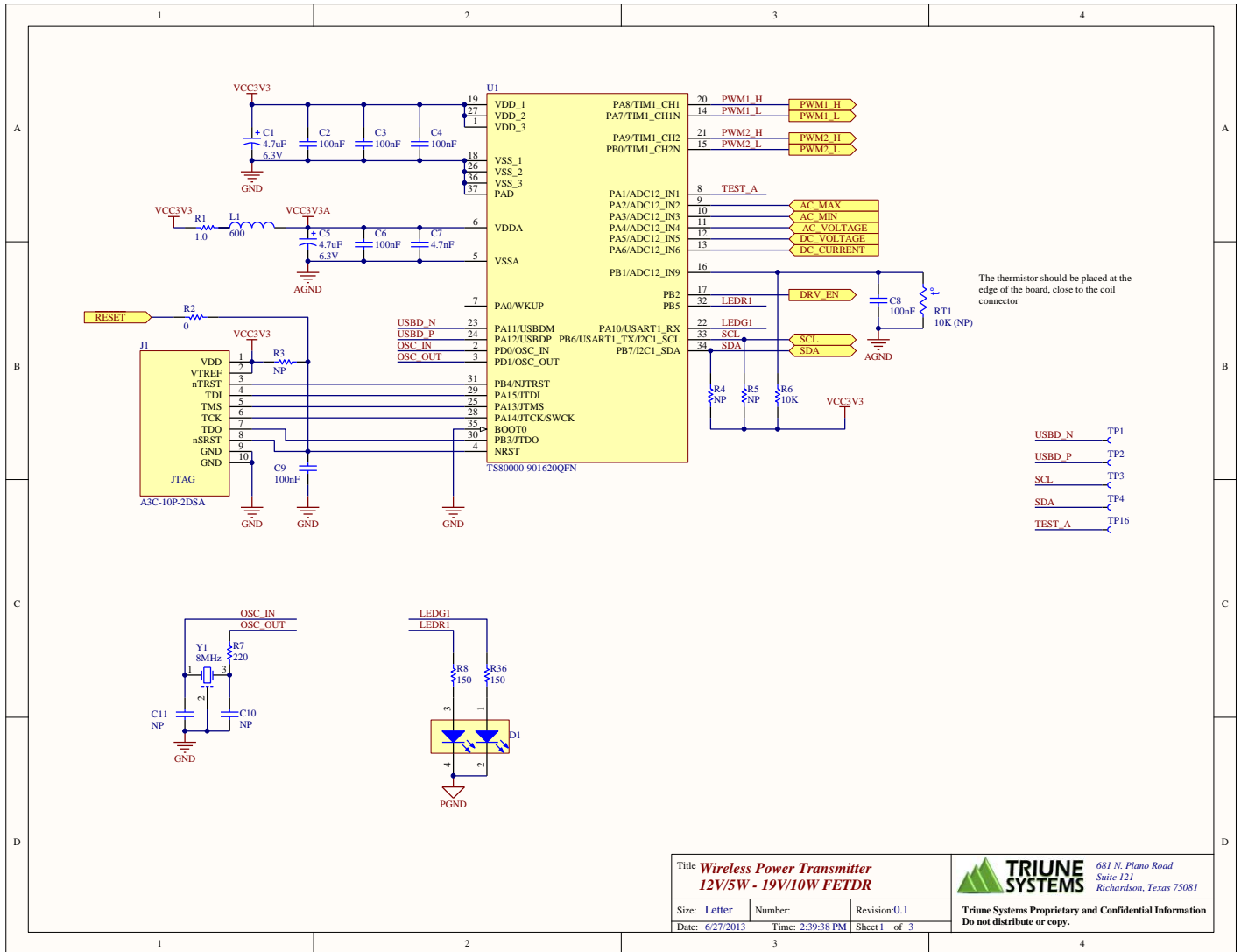

Figure 1: TS80000 Application Schematic (control section)

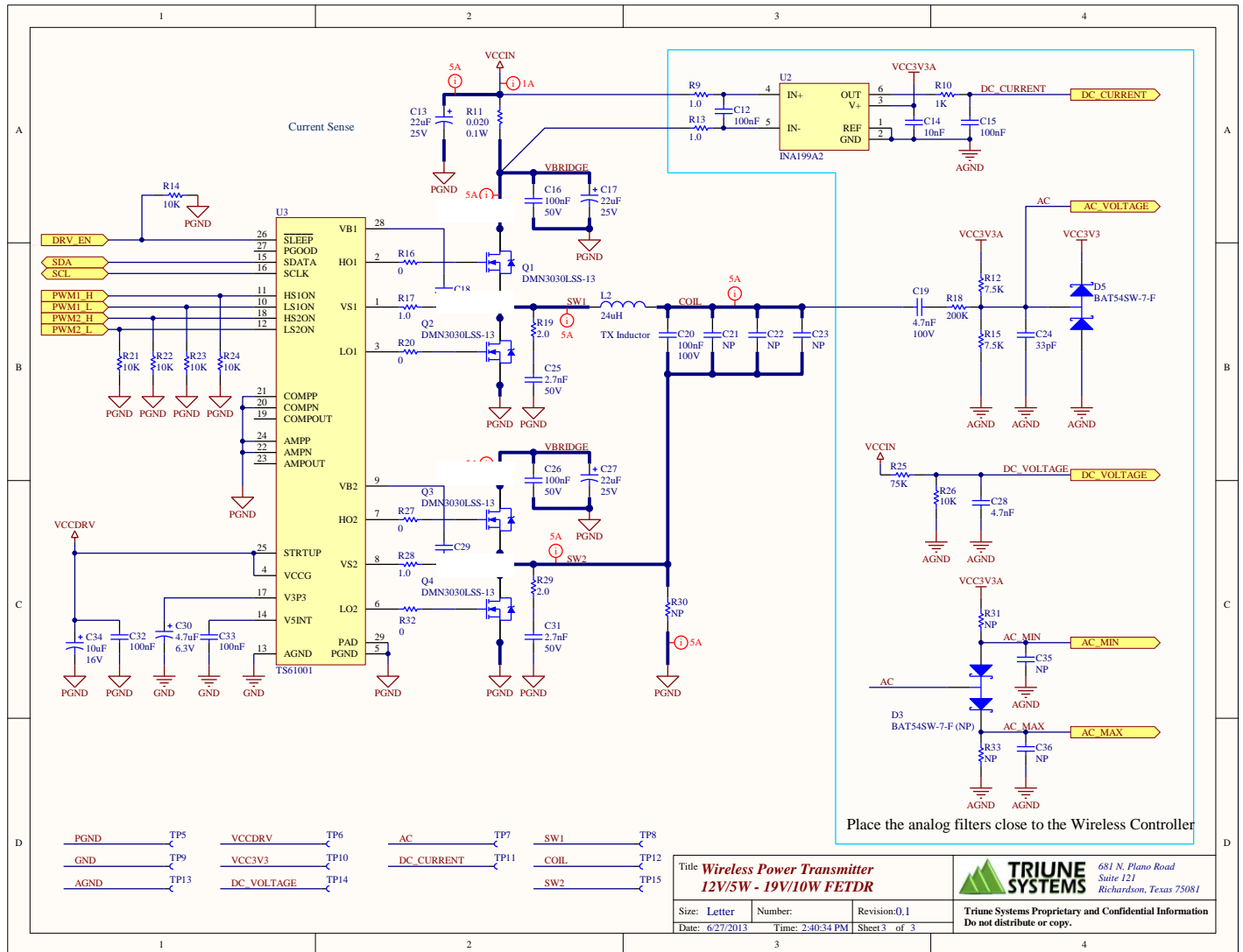

Figure 2: TS80000 Application Schematic (power section)

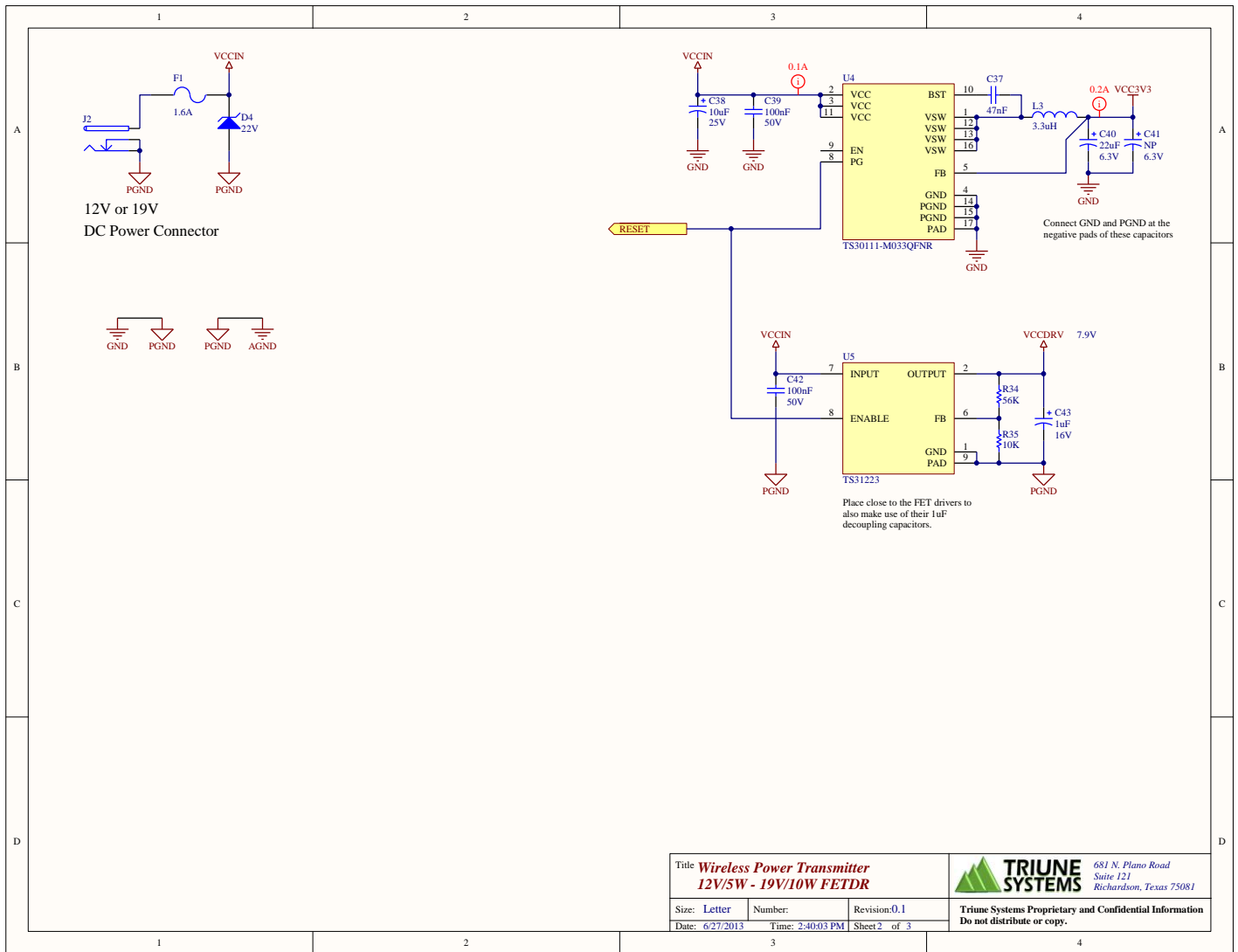
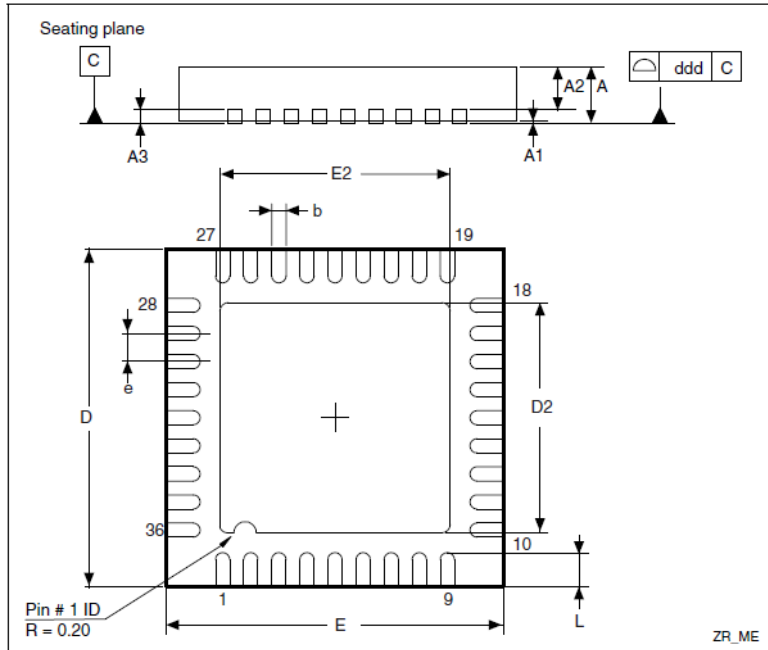

Figure 3: TS80000 Application Schematic (power supply section)

## PACKAGE DIMENSIONS

**VFQFPN36 6 x 6 mm, 0.5 mm pitch,  
package outline<sup>(1)</sup>**



**Recommended footprint  
(dimensions in mm)<sup>(1)(2)</sup>**

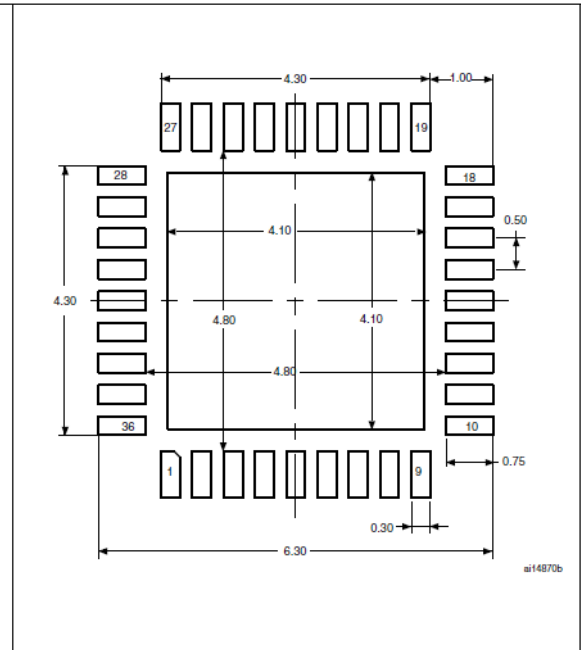

1. Drawing is not to scale.
2. All leads/pads should also be soldered to the PCB to improve the lead solder joint life.

**VFQFPN36 6 x 6 mm, 0.5 mm pitch, package mechanical data**

Symbol	millimeters			inches <sup>(1)</sup>		
	Min	Typ	Max	Min	Typ	Max
A	0.800	0.900	1.000	0.0315	0.0354	0.0394
A1		0.020	0.050		0.0008	0.0020
A2		0.650	1.000		0.0256	0.0394
A3		0.250			0.0098	
b	0.180	0.230	0.300	0.0071	0.0091	0.0118
D	5.875	6.000	6.125	0.2313	0.2362	0.2411
D2	1.750	3.700	4.250	0.0689	0.1457	0.1673
E	5.875	6.000	6.125	0.2313	0.2362	0.2411
E2	1.750	3.700	4.250	0.0689	0.1457	0.1673
e	0.450	0.500	0.550	0.0177	0.0197	0.0217
L	0.350	0.550	0.750	0.0138	0.0217	0.0295
ddd		0.080			0.0031	

1. Values in inches are converted from mm and rounded to 4 decimal digits.

---

## ROHS AND REACH COMPLIANCE

Triune Systems is fully committed to environmental quality. All Triune Systems materials and suppliers are fully compliant with RoHS (European Union Directive 2011/65/EU), REACH SVHC Chemical Restrictions (EC 1907/2006), IPC-1752 Level 3 materials declarations, and their subsequent amendments. Triune Systems maintains certified laboratory reports for all product materials, from all suppliers, which show full compliance to restrictions on the following:

- Cadmium (Cd)
- Chlorofluorocarbons (CFCs)
- Chlorinate Hydrocarbons (CHCs)
- Halons (Halogen free)
- Hexavalent Chromium (CrVI)
- Hydrobromofluorocarbons (HBFCs)
- Hydrochlorofluorocarbons (HCFCs)
- Lead (Pb)
- Mercury (Hg)
- Perfluorocarbons (PFCs)
- Polybrominated biphenyls (PBB)
- Polybrominated Diphenyl Ethers (PBDEs)



**Legal Notices**

Information contained in this publication regarding device applications and the like is provided only for your convenience and may be superseded by updates. It is your responsibility to ensure that your application meets with your specifications. "Typical" parameters which may be provided in Triune Systems data sheets and/or specifications can and do vary in different applications and actual performance may vary over time. All operating parameters, including "Typicals" must be validated for your application by your technical experts. TRIUNE SYSTEMS MAKES NO REPRESENTATIONS OR WARRANTIES OF ANY KIND WHETHER EXPRESS OR IMPLIED, WRITTEN OR ORAL, STATUTORY OR OTHERWISE, RELATED TO THE INFORMATION, INCLUDING BUT NOT LIMITED TO ITS CONDITION, QUALITY, PERFORMANCE, MERCHANTABILITY OR FITNESS FOR PURPOSE. Triune Systems disclaims all liability arising from this information and its use. Triune System products are not designed, intended, or authorized for use as components in systems intended for surgical implant into the body, or other applications intended to support or sustain life, or for any other application in which the failure of the Triune Systems product could create a situation where personal injury or death may occur. Should the Buyer purchase or use Triune Systems products for any such unintended or unauthorized application, the Buyer shall indemnify and hold Triune Systems, and its officers, employees, subsidiaries, affiliates, and distributors harmless against all claims, costs, damages, and expenses, and reasonable attorney fees arising out of, directly or indirectly, any claim of personal injury or death associated with such unintended or unauthorized use, even if such claim alleges that Triune Systems was negligent regarding the design or manufacture of the part. No licenses are conveyed, implicitly or otherwise, under any Triune Systems intellectual property rights.

**Trademarks**

The Triune Systems® name and logo, MPPT-lite™, and nanoSmart® are trademarks of Triune Systems, LLC. in the U.S.A..

All other trademarks mentioned herein are property of their respective companies.

© 2013 Triune Systems, LLC. All Rights Reserved.