



Ultra-Fast ECL-Output Comparator

General Description

The MAX9690 is an ultra-fast ECL comparator manufactured with a high-frequency bipolar process ($f_T = 6\text{GHz}$) capable of very short propagation delays. This design maintains the excellent DC matching characteristics normally found only in slower comparators. The MAX9690 is similar in function to the MAX9685, except the latch-enable input is eliminated.

The MAX9690 is pin-compatible with the CMP-08 but exceeds the AC characteristics of that device.

The MAX9690 has differential inputs and complementary outputs that are fully compatible with ECL-logic levels. Output current levels are capable of driving 50Ω terminated transmission lines. The ultra-fast operation makes signal processing possible at frequencies in excess of 600MHz .

Applications

High-Speed A/D Converters
 High-Speed Line Receivers
 Peak Detectors
 Threshold Detectors

Functional Diagram

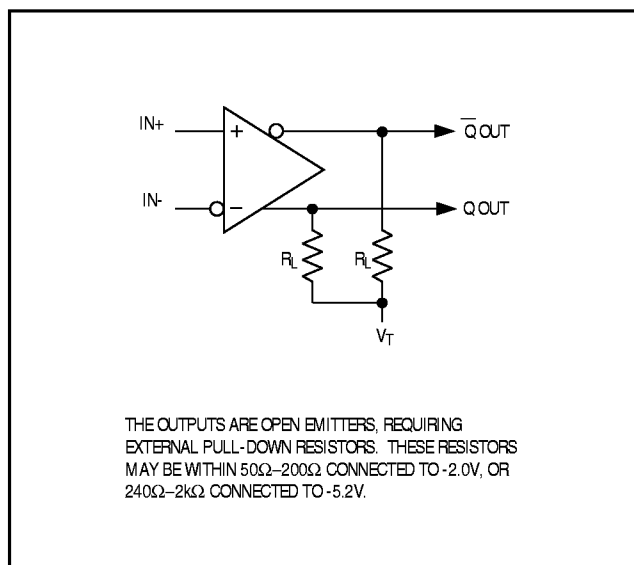

Features

- ◆ 1.3ns Propagation Delay
- ◆ +5V, -5.2V Power Supplies
- ◆ Pin-Compatible with CMP-08
- ◆ Available in Commercial, Extended-Industrial, and Military Temperature Ranges
- ◆ Available in Small-Outline Package

Ordering Information

PART	TEMP. RANGE	PIN-PACKAGE
MAX9690CPA-4	0°C to $+70^\circ\text{C}$	8 Plastic DIP
MAX9690CSA	0°C to $+70^\circ\text{C}$	8 SO
MAX9690CJA	0°C to $+70^\circ\text{C}$	8 CERDIP
MAX9690EPA	-40°C to $+85^\circ\text{C}$	8 Plastic DIP
MAX9690ESA	-40°C to $+85^\circ\text{C}$	8 SO
MAX9690MJA-4	-55°C to $+125^\circ\text{C}$	8 CERDIP

Pin Configuration

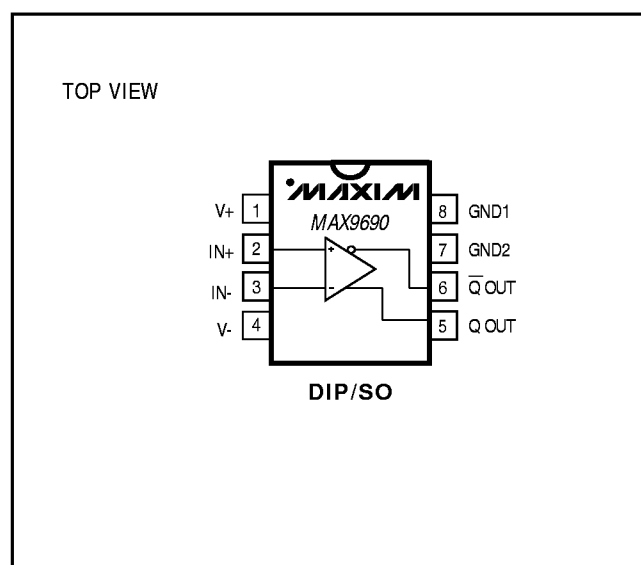

MAX9690



Ultra-Fast ECL-Output Comparator

MAX9690

ABSOLUTE MAXIMUM RATINGS

Supply Voltages.....	±6V
Input Voltages.....	±5V
Differential Input Voltages.....	±3.5V
Output Current.....	30mA
Continuous Power Dissipation (T _A = +70°C)	
Plastic DIP (derate 9.09mW/°C above +70°C).....	727mW
SO (derate 5.88mW/°C above +70°C).....	471mW
CERDIP (derate 8.00mW/°C above +70°C).....	640mW

Operating Temperature Ranges

MAX9690C_A.....	0°C to +70°C
MAX9690E_A.....	-40°C to +85°C
MAX9690MJA.....	-55°C to +125°C
Storage Temperature Range.....	-55°C to +150°C
Lead Temperature (soldering, 10sec).....	+300°C

Stresses beyond those listed under "Absolute Maximum Ratings" may cause permanent damage to the device. These are stress ratings only, and functional operation of the device at these or any other conditions beyond those indicated in the operational sections of the specifications is not implied. Exposure to absolute maximum rating conditions for extended periods may affect device reliability.

ELECTRICAL CHARACTERISTICS

(V₊ = +5V, V₋ = -5.2V, R_L = 50Ω, V_T = -2V, T_A = +25°C, unless otherwise noted.)

PARAMETER	SYMBOL	CONDITIONS	MAX9690C/E			MAX9690M			UNITS	
			MIN	TYP	MAX	MIN	TYP	MAX		
Input Offset Voltage	V _{OS}	T _A = +25°C	-5		5	-5		5	mV	
		T _A = T _{MIN} to T _{MAX} (Note 1)	-7		7	-8		8		
Temperature Coefficient	ΔV _{OS} /ΔT		10			15			μV/°C	
Input Offset Current	I _{OS}	T _A = +25°C			5			5	μA	
		T _A = T _{MIN} to T _{MAX}			8			12		
Input Bias Current	I _B	T _A = +25°C		10	20		10	20	μA	
		T _A = T _{MIN} to T _{MAX}			30			40		
Input Voltage Range	V _{CM}	(Note 1)	-2.5		+2.5	-2.5		+2.5	V	
Common-Mode Rejection Ratio	CMRR	(Note 1)	80			80			dB	
Power-Supply Rejection Ratio	PSRR		60			60			dB	
Input Resistance	R _{IN}	(Note 1)	60			60			kΩ	
Input Capacitance	C _{IN}		3			3			pF	
Logic Output High Voltage	V _{OH}	MAX9690C, MAX9690M	T _A = T _{MIN}	-1.05		-0.87	-1.16		-0.89	V
			T _A = T _{MAX}	-0.89		-0.70	-0.88		-0.69	
			T _A = +25°C	-0.96		-0.81	-0.96		-0.81	
		MAX9690E	T _A = T _{MIN}	-1.14		-0.88				
			T _A = T _{MAX}	-0.88		-0.70				
			T _A = +25°C	-0.96		-0.81				
Logic Output Low Voltage	V _{OL}	MAX9690C, MAX9690M	T _A = T _{MIN}	-1.83		-1.57	-1.82		-1.55	V
			T _A = T _{MAX}	-1.89		-1.65	-1.90		-1.65	
			T _A = +25°C	-1.85		-1.65	-1.85		-1.65	
		MAX9690E	T _A = T _{MIN}	-1.90		-1.65				
			T _A = T _{MAX}	-1.83		-1.57				
			T _A = +25°C	-1.85		-1.65				
Positive Supply Current		T _A = +25°C		16	22		16	22	mA	
		T _A = T _{MIN} to T _{MAX}			24			25		
Negative Supply Current		T _A = +25°C		20	32		20	32	mA	
		T _A = T _{MIN} to T _{MAX}			36			37		

Ultra-Fast ECL-Output Comparator

MAX9690

SWITCHING CHARACTERISTICS

($V_+ = +5V$, $V_- = -5.2V$, $R_L = 50\Omega$, $V_T = -2V$, $T_A = +25^\circ C$, unless otherwise noted.)

PARAMETER	SYMBOL	CONDITIONS	MAX9690C/E			MAX9690M			UNITS
			MIN	TYP	MAX	MIN	TYP	MAX	
Input to Output High (Notes 1, 2)	t_{pd+}	$T_A = +25^\circ C$	1.3	1.8		1.3	1.8	ns	
		$T_A = 0^\circ C$ to $+70^\circ C$	1.5	2.0					
		$T_A = -55^\circ C$ to $+125^\circ C$				1.7	2.4		
Input to Output Low (Notes 1, 2)	t_{pd-}	$T_A = +25^\circ C$	1.3	1.8		1.3	1.8	ns	
		$T_A = 0^\circ C$ to $+70^\circ C$	1.5	2.0					
		$T_A = -55^\circ C$ to $+125^\circ C$				1.7	2.4		

Note 1: Not tested, guaranteed by design.

Note 2: $V_{IN} = 100mV$, $V_{OD} = 10mV$.

Applications Information

Layout

Because of the MAX9690's large gain-bandwidth characteristic, special precautions need to be taken if its high-speed capabilities are to be used. A PC board with a ground plane is mandatory. Mount all decoupling capacitors as close to the power-supply pins as possible, and process the ECL outputs in microstrip fashion, consistent with the load termination of 50Ω to 120Ω . For low-impedance applications, microstrip layout at the input may also be helpful. Pay close attention to the bandwidth of the decoupling and terminating components. Chip components can be used to minimize lead inductance.

Input Slew-Rate Requirements

As with all high-speed comparators, the high gain-bandwidth product of these devices creates oscillation problems when the input traverses through the linear region. For clean switching without oscillation or steps in the output waveform, the input must meet certain minimum slew-rate requirements. The tendency of the part to oscillate is a function of the layout and source impedance of the circuit employed. Both poor layout and larger source impedance increase the minimum slew-rate requirement.

Timing Diagram

The timing diagram illustrates the series of events that completes the compare function, under worst-case conditions. The leading edge of the input signal (illustrated as a large-amplitude, small-overdrive pulse) switches the comparator. Outputs \bar{Q} and Q are similar in timing.

Definition of Terms

- V_{OS} Input Offset Voltage—The voltage required between the input terminals to obtain 0V differential at the output.
- V_{IN} Input Voltage Pulse Amplitude
- V_{OD} Input Voltage Overdrive
- t_{pd+} Input to Output High Delay—The propagation delay measured from the time the input signal crosses the input offset voltage to the 50% point of an output low-to-high transition.
- t_{pd-} Input to Output Low Delay—The propagation delay measured from the time the input signal crosses the input offset voltage to the 50% point of an output high-to-low transition.

Ultra-Fast ECL-Output Comparator

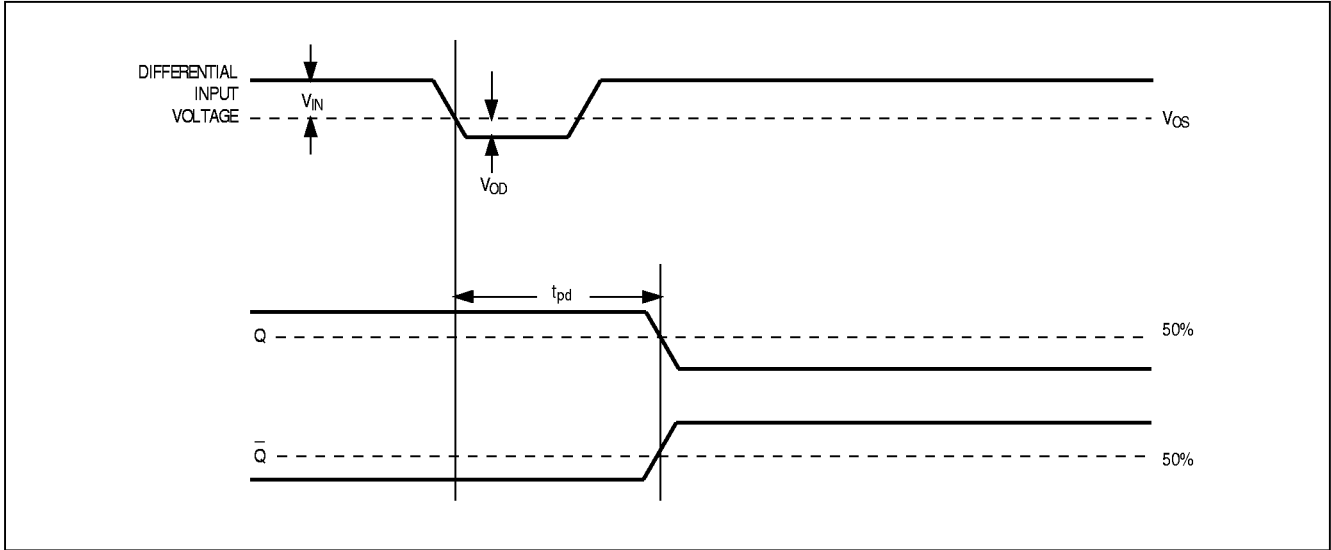

Figure 1. Timing Diagram

Maxim cannot assume responsibility for use of any circuitry other than circuitry entirely embodied in a Maxim product. No circuit patent licenses are implied. Maxim reserves the right to change the circuitry and specifications without notice at any time.

4 Maxim Integrated Products, 120 San Gabriel Drive, Sunnyvale, CA 94086 408-737-7600

Package Information

This section contains physical dimensions for all packages currently supplied by Maxim.

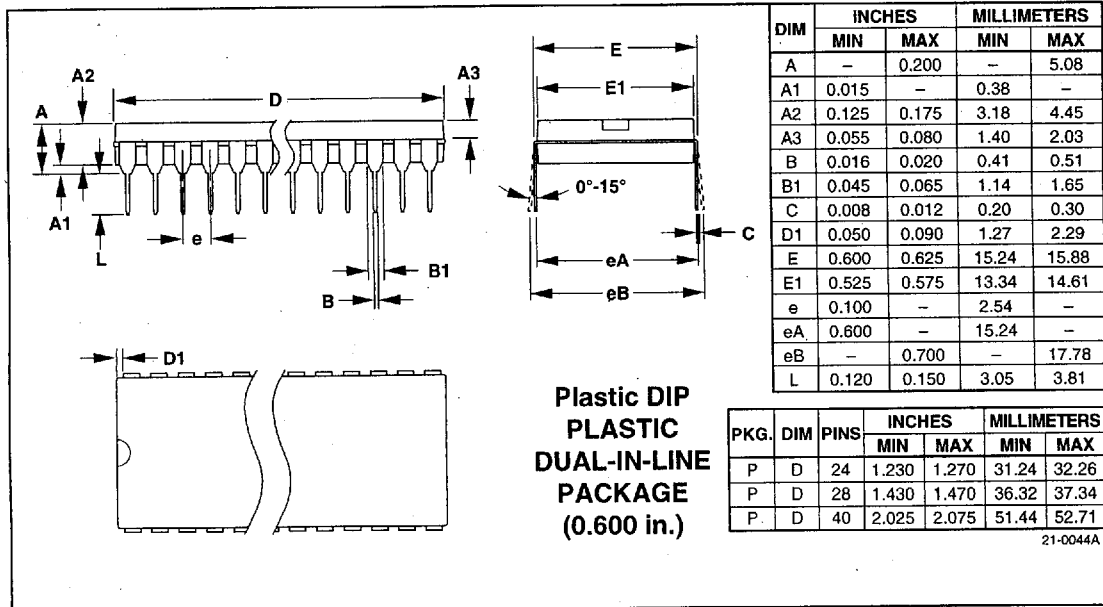
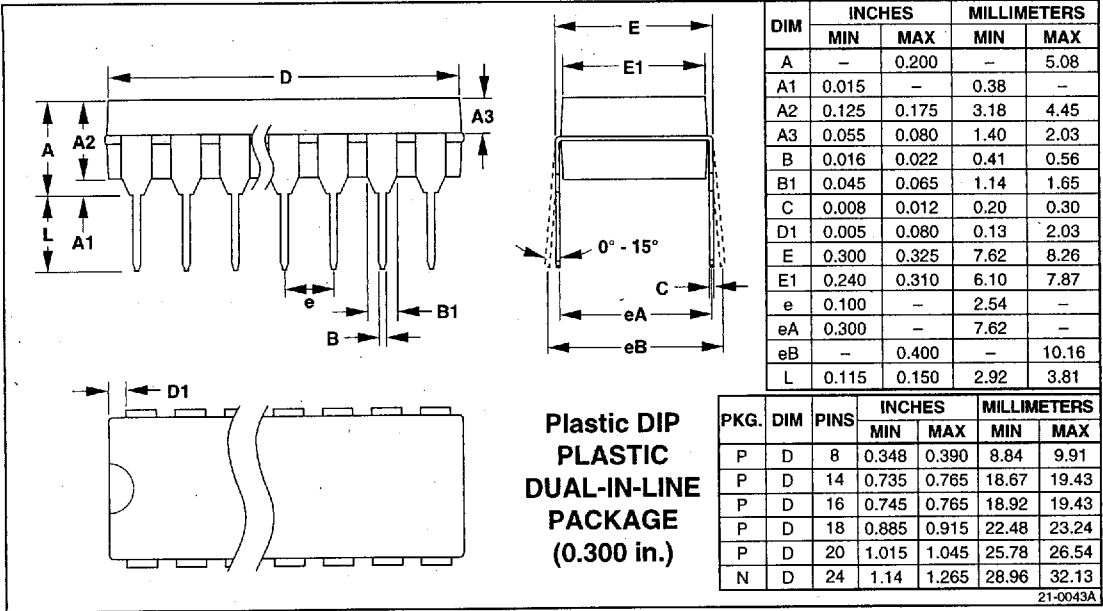

A

Package Information

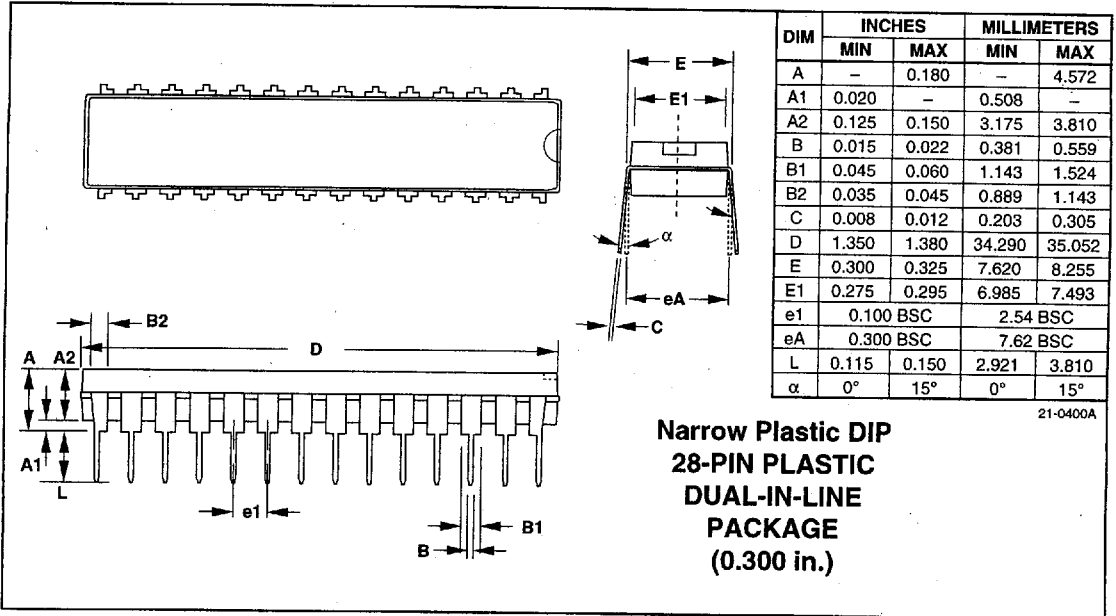

**Narrow Plastic DIP
28-PIN PLASTIC
DUAL-IN-LINE
PACKAGE
(0.300 in.)**

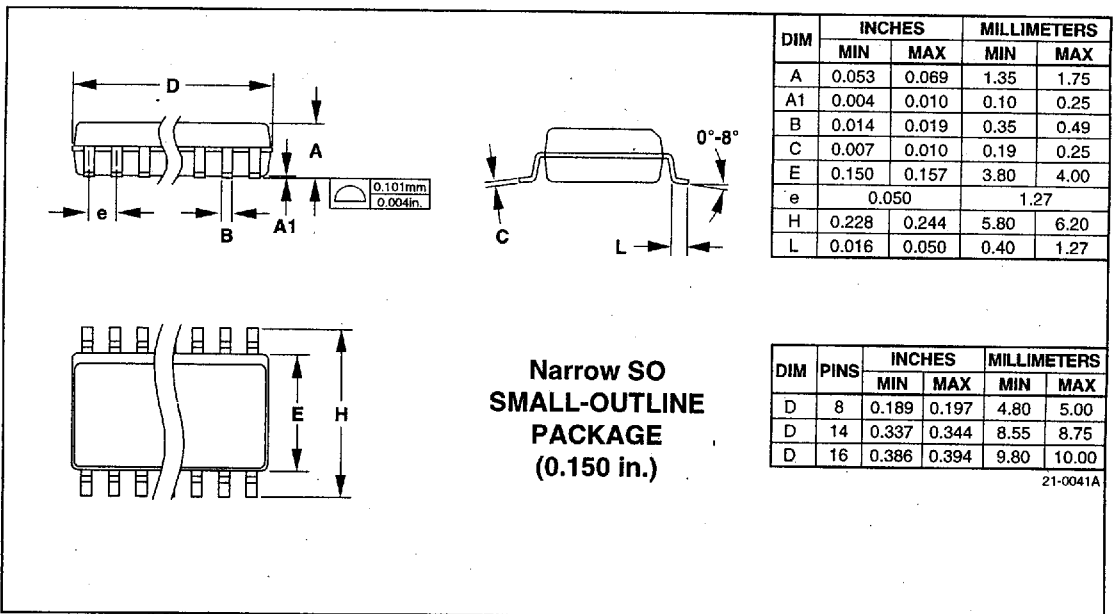

**Narrow SO
SMALL-OUTLINE
PACKAGE
(0.150 in.)**

Package Information

