

## Features

- Low capacitance - 0.3 pF
- ESD protection
- Vcc + six I/O data lines
- RoHS compliant\*

## Applications

- USB 3.0
- HDMI 1.4
- High speed port protection
- Portable electronics

# CDDFN10-0506N - TVS/Steering Diode Array

### General Information

The Bourns® Model CDDFN10-0506N device provides ESD and EFT protection for high speed data ports meeting IEC 61000-4-2 (ESD) and IEC 61000-4-4 (EFT) requirements. The Transient Voltage Suppressor array, protecting up to six data lines, offers a Working Peak Voltage of 5.0 V.

The DFN-10 package is easy to handle with standard pick and place equipment and their flat configuration minimizes roll away.

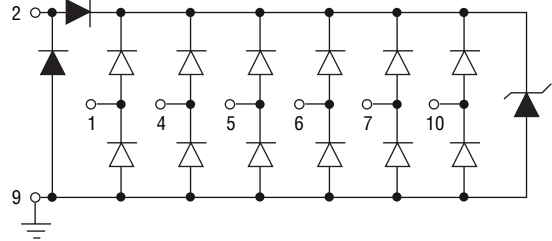

### Absolute Maximum Ratings, T<sub>A</sub> = 25 °C (Unless Otherwise Noted)

Parameter	Symbol	Rating	Unit
Peak Pulse Current (t <sub>p</sub> = 8/20 μS)	I <sub>pp</sub>	3.5	A
Peak Pulse Power (t <sub>p</sub> = 8/20 μS)	P <sub>pk</sub>	40	W
Operating Supply Voltage (V <sub>dd</sub> - Gnd)	V <sub>DC</sub>	6	V
DC Voltage on any I/O Pad	V <sub>IO</sub>	(Gnd -0.5) to (V <sub>dd</sub> +0.5)	V
Storage Temperature	T <sub>STG</sub>	-55 to +150	°C
Operating Temperature	T <sub>OPR</sub>	-40 to +85	°C

### Electrical Characteristics (@ T<sub>A</sub> = 25 °C Unless Otherwise Noted)

Parameter	Symbol	Min.	Typ.	Max.	Unit
Working Peak Voltage <sup>1</sup>	V <sub>WM</sub>			5.0	V
Breakdown Voltage @ 1 mA <sup>1</sup>	V <sub>BR</sub>	6.0			V
Forward Voltage @ 15 mA <sup>2</sup>	V <sub>F</sub>		0.8	1.2	V
Leakage Current @ V <sub>WM</sub> <sup>1</sup>	I <sub>L</sub>			2.5	μA
Leakage Current @ V <sub>WM</sub> <sup>3</sup>	I <sub>IO</sub>			1	μA
Channel Capacitance <sup>3</sup> @ 2.5 V, 1 MHz	C <sub>IO</sub>		0.25	0.35	pF
Channel to Channel Capacitance <sup>4</sup> @ 2.5 V, 1 MHz	C <sub>CROSS</sub>		0.05	0.07	pF
ESD Protection per IEC 61000-4-2 Contact Discharge Air Discharge		±8 ±15			kV kV
ESD Dynamic Turn-on Resistance <sup>5</sup>	R <sub>dynamic_I/O</sub>		0.35		Ω
ESD Dynamic Turn-on Resistance <sup>6</sup>	R <sub>dynamic_VDD</sub>		0.2		Ω
EFT Protection per IEC 61000-4-4 @ 5/50 ns		40			A

Note 1: Pin 2 to Pin 9

Note 2: Pin 9 to Pin 2.

Note 3: Pin 1, 4, 5, 6, 7 or 10 to Ground.

Note 4: Between I/O 1, 4, 5, 6, 7 or 10.

Note 5: Any I/O Pin to Ground.

Note 6: V<sub>DD</sub> Pin to Ground.

# CDDFN10-0506N - TVS/Steering Diode Array



## Product Dimensions

This is a molded DFN10 package with lead free 100 % Matte Sn on the lead frame. It has a flammability rating of UL 94V-0.

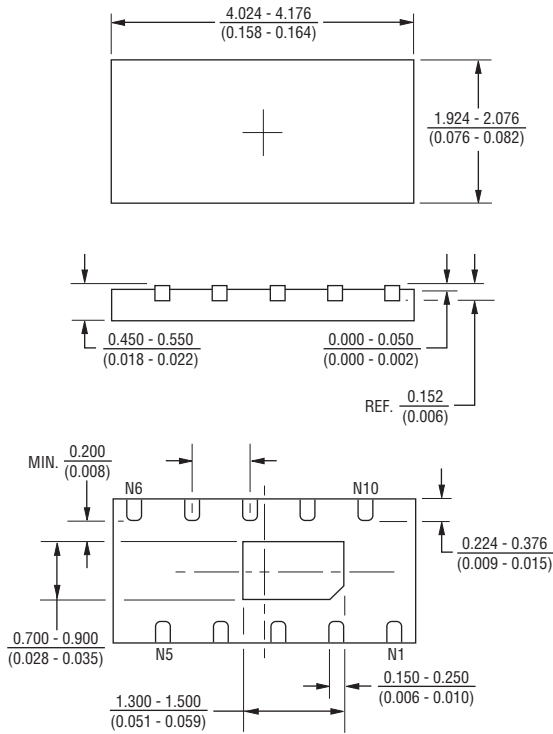

DIMENSIONS:  $\frac{\text{MM}}{\text{(INCHES)}}$

## Typical Part Marking

CDDFN10-0506N .....506

## Recommended Footprint

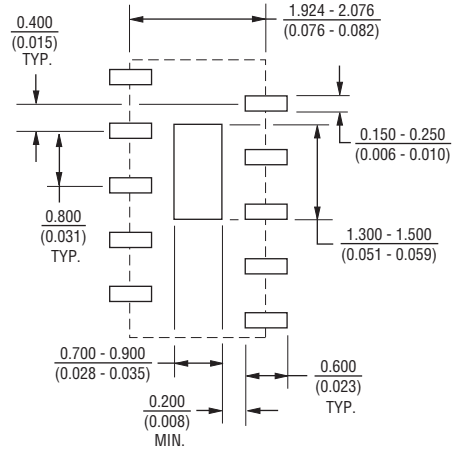

## How to Order

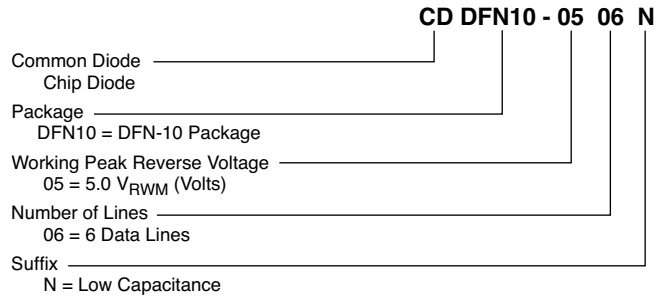

## Pin Out

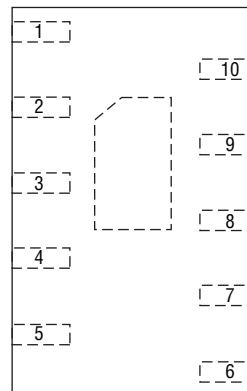

Pin	Function
1	I/O LINE
2	V <sub>CC</sub> LINE
3	N.C.
4	I/O LINE
5	I/O LINE
6	I/O LINE
7	I/O LINE
8	N.C.
9	Ground
10	I/O LINE

# CDDFN10-0506N - TVS/Steering Diode Array

**BOURNS®**

## Reference Application

Bourns® Model CDDFN10-0506N is designed to protect high speed data ports from ESD transients. For high speed ports above 5 Gb/s such as USB 3.0, differential signalling is used where the need to keep impedance constant is a critical requirement. The use of a DFN-10 package using a “feed through” layout provides a minimum impedance change on the high speed data line while the ultra-low capacitance performance of the device limits the signal loss degradation of each channel.

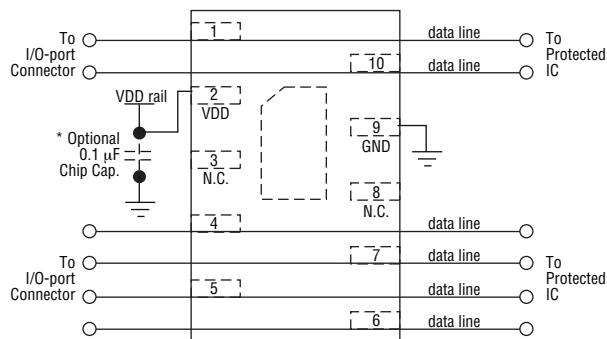

**CDDFN10-0506N Layout on USB 3.0 Port**

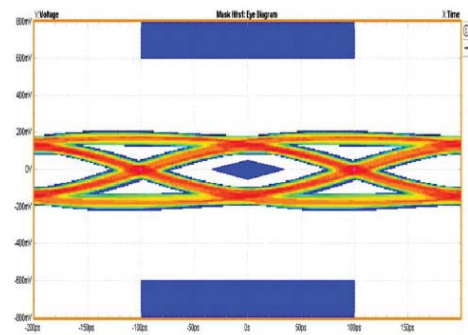

**CDDFN10-0506N Using 5 GHz Eye Diagram**

# CDDFN10-0506N - TVS/Steering Diode Array

**BOURNS®**

## Performance Curves

### Insertion Loss S21

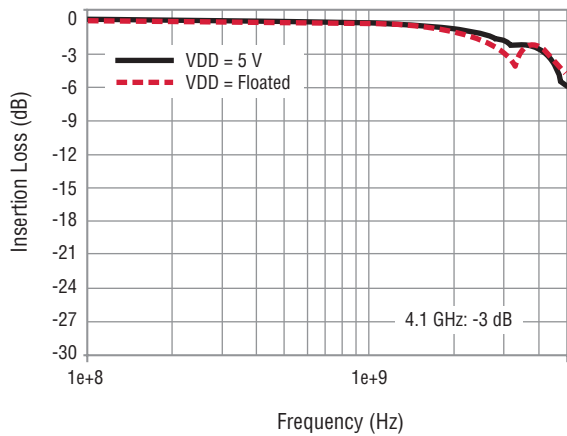

### Crosstalk Between I/Os

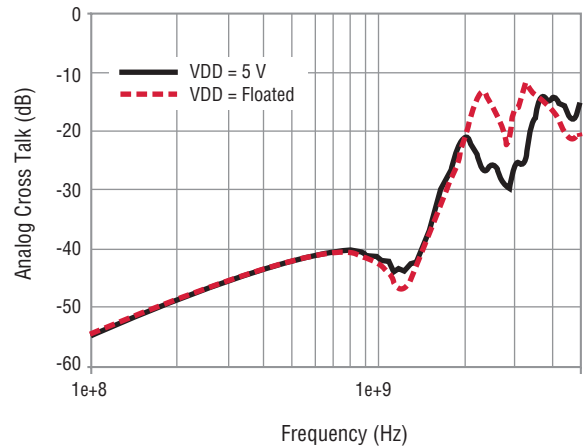

### Channel Capacitance versus Voltage

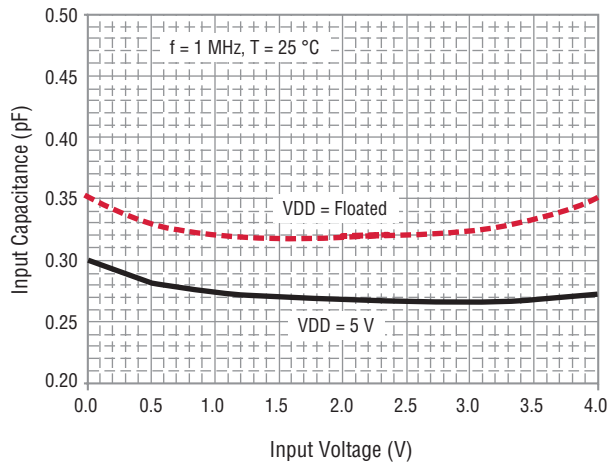

### Channel to Channel Capacitance versus Voltage

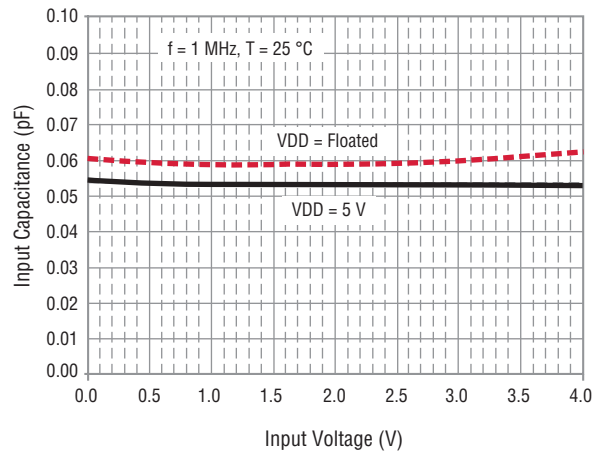

### Typical V/I Characteristic

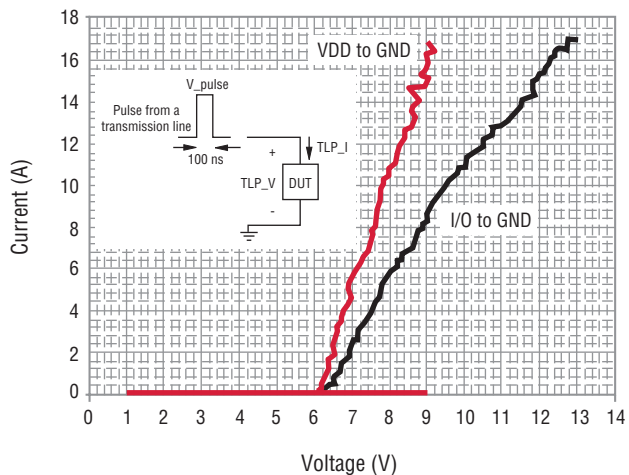

Specifications are subject to change without notice.  
Customers should verify actual device performance in their specific applications.

# CDDFN10-0506N - TVS/Steering Diode Array

**BOURNS®**

## Packaging Information

The product will be dispensed in tape and reel format (see diagram below).

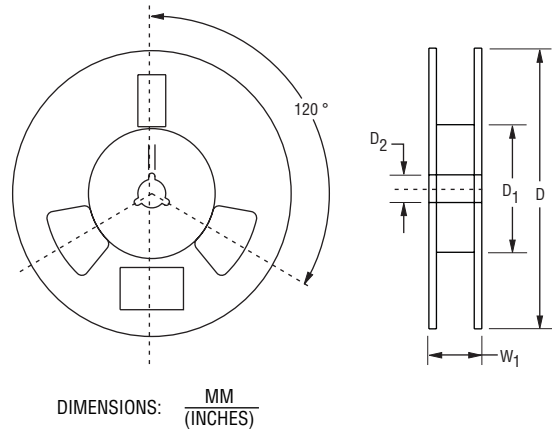
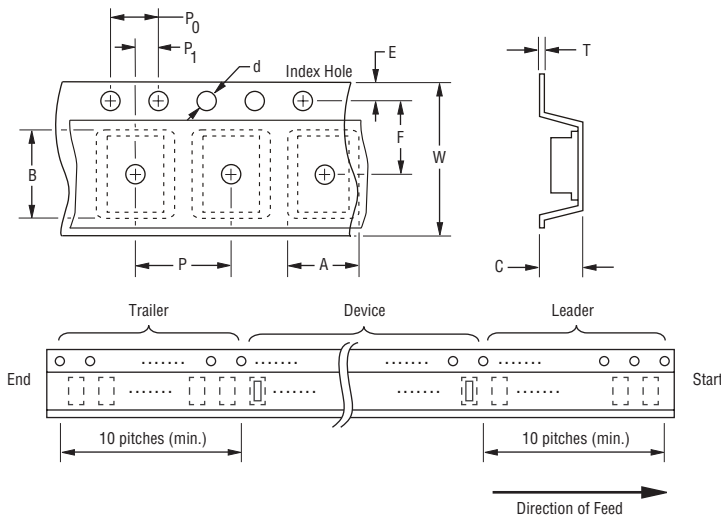

Devices are packed in accordance with EIA standard RS-481-A.

Item	Symbol	DFN-10
Carrier Width	A	$\frac{2.90 \pm 0.10}{(0.114 \pm 0.004)}$
Carrier Length	B	$\frac{2.90 \pm 0.10}{(0.114 \pm 0.004)}$
Carrier Depth	C	$\frac{0.90 \pm 0.10}{(0.035 \pm 0.004)}$
Sprocket Hole	d	$\frac{1.55 \pm 0.05}{(0.061 \pm 0.002)}$
Reel Outside Diameter	D	$\frac{178}{(7.008)}$
Reel Inner Diameter	D <sub>1</sub>	$\frac{50.0}{(1.969)}$ MIN.
Feed Hole Diameter	D <sub>2</sub>	$\frac{13.0 \pm 0.20}{(0.512 \pm 0.008)}$
Sprocket Hole Position	E	$\frac{1.75 \pm 0.10}{(0.069 \pm 0.004)}$
Punch Hole Position	F	$\frac{3.50 \pm 0.05}{(0.138 \pm 0.002)}$
Punch Hole Pitch	P	$\frac{4.00 \pm 0.10}{(0.157 \pm 0.004)}$
Sprocket Hole Pitch	P <sub>0</sub>	$\frac{4.00 \pm 0.10}{(0.157 \pm 0.004)}$
Embossment Center	P <sub>1</sub>	$\frac{2.00 \pm 0.05}{(0.079 \pm 0.002)}$
Overall Tape Thickness	T	$\frac{0.20 \pm 0.10}{(0.008 \pm 0.004)}$
Tape Width	W	$\frac{8.00 \pm 0.20}{(0.315 \pm 0.008)}$
Reel Width	W <sub>1</sub>	$\frac{14.4}{(0.567)}$ MAX.
Quantity per Reel	--	3000

REV. 06/12

Specifications are subject to change without notice. Customers should verify actual device performance in their specific applications.