

Reverse Voltage 90 to 100V
 Forward Current 30A
 Maximum T_J 175°C

TO-220AB (MBR30H90CT, MBR30H100CT)

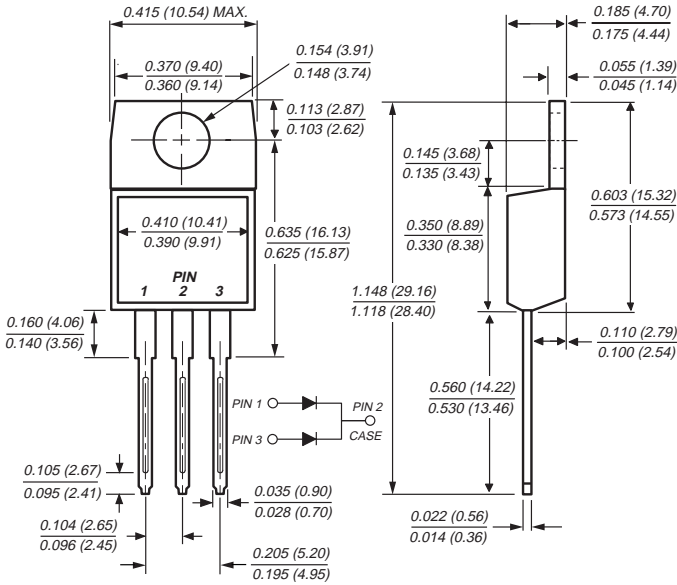

ITO-220AB (MBRF30H90CT, MBRF30H100CT)

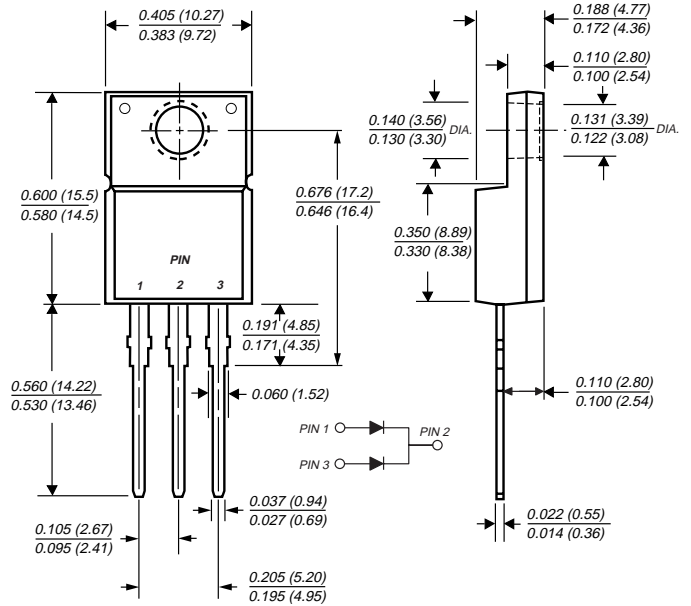

Mounting Pad Layout TO-263AB

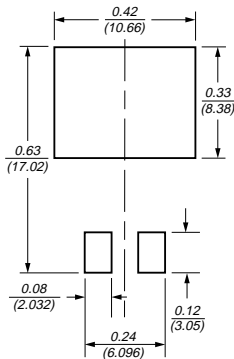

TO-263AB (MBRB30H90CT, MBRB30H100CT)

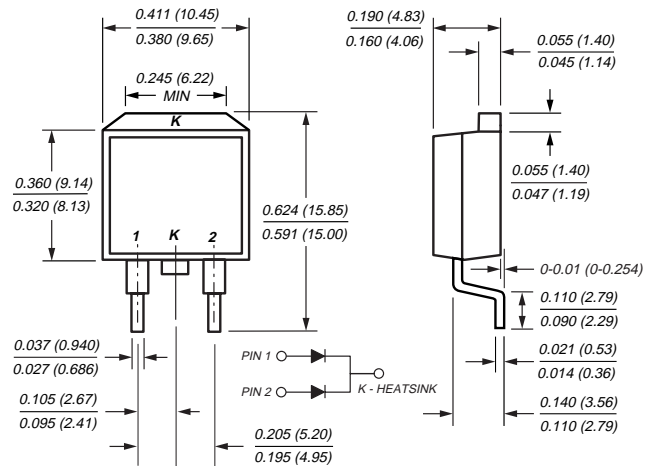

Features

- Plastic package has Underwriters Laboratory Flammability Classification 94V-0
- Dual rectifier construction, positive center tap
- Metal silicon junction, majority carrier conduction
- Low power loss, high efficiency
- Guardring for overvoltage protection
- For use in low voltage, high frequency inverters, free wheeling, and polarity protection applications

Mechanical Data

Case: JEDEC TO-220AB, ITO-220AB & TO-263AB molded plastic body

Terminals: Plated leads, solderable per MIL-STD-750, Method 2026

High temperature soldering guaranteed: 250°C/10 seconds, 0.25" (6.35mm) from case

Polarity: As marked

Mounting Position: Any

Mounting Torque: 10 in-lbs maximum

Weight: 0.08oz., 2.24g

Maximum Ratings (T_C = 25°C unless otherwise noted)

Parameter	Symbol	MBR30H90CT	MBR30H100CT	Unit
Maximum repetitive peak reverse voltage	V _{RRM}	90	100	V
Working peak reverse voltage	V _{RWM}	90	100	V
Maximum DC blocking voltage	V _{DC}	90	100	V
Maximum average forward rectified current <i>Total device</i> (see fig. 1) <i>Per leg</i>	I _{F(AV)}	30 15		A
Peak forward surge current 8.3ms single half sine-wave superimposed on rated load (JEDEC Method) per leg	I _{FSM}	275		A
Peak repetitive reverse current per leg at t _p = 2μs, 1KHz	I _{RRM}	1.0		A
Voltage rate of change (rated V _R)	dv/dt	10,000		V/μs
Operating junction and storage temperature range	T _J , T _{STG}	-65 to +175		°C
RMS Isolation voltage (MBRF type only) from terminals to heatsink with t = 1 second, RH ≤ 30%	V _{ISOL}	4500 ⁽¹⁾ 3500 ⁽²⁾ 1500 ⁽³⁾		V

Electrical Characteristics (T_C = 25°C unless otherwise noted)

Parameter	Symbol	Value	Unit
Maximum instantaneous forward voltage per leg ⁽⁴⁾	V _F	at I _F = 15A, T _J = 25°C	0.82
		at I _F = 15A, T _J = 125°C	0.67
		at I _F = 30A, T _J = 25°C	0.93
		at I _F = 30A, T _J = 125°C	0.80
Maximum reverse current per leg at working peak reverse voltage ⁽⁴⁾	I _R	T _J = 25°C	5.0
		T _J = 125°C	6.0

Thermal Characteristics (T_C = 25°C unless otherwise noted)

Parameter	Symbol	MBR	MBRF	MBRB	Unit
Typical thermal resistance per leg	R _{θJC}	1.9	4.6	1.9	°C/W

Notes:

- (1) Clip mounting (on case), where lead does not overlap heatsink with 0.110" offset
- (2) Clip mounting (on case), where leads do overlap heatsink
- (3) Screw mounting with 4-40 screw, where washer diameter is ≤ 4.9 mm (0.19")
- (4) Pulse test: 300μs pulse width, 1% duty cycle

Ordering Information

Product	Case	Package Code	Package Option
MBR30H90CT - MBR30H100CT	TO-220AB	45	Anti-Static tube, 50/tube, 2K/carton
MBRF30H90CT - MBRF30H100CT	ITO-220AB	45	Anti-Static tube, 50/tube, 2K/carton
MBRB30H90CT - MBRB30H100CT	TO-263AB	31	13" reel, 800/reel, 4.8K/carton
		45	Anti-Static tube, 50/tube, 2K/carton
		81	Anti-Static 13" reel, 800/reel, 4.8K/carton



KERSEMI

Fig. 1 – Forward Derating Curve Per Leg

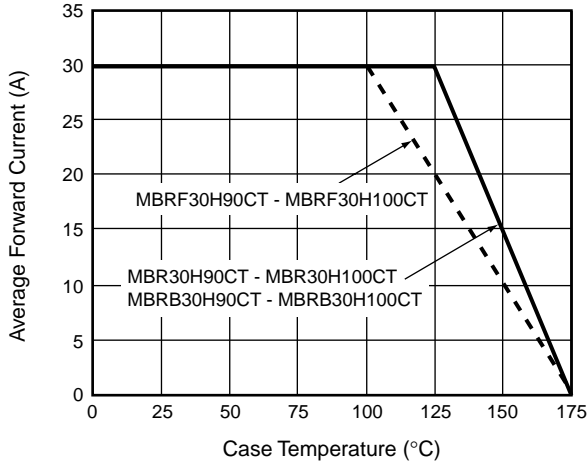

Fig. 2 – Maximum Non-Repetitive Peak Forward Surge Current Per Leg

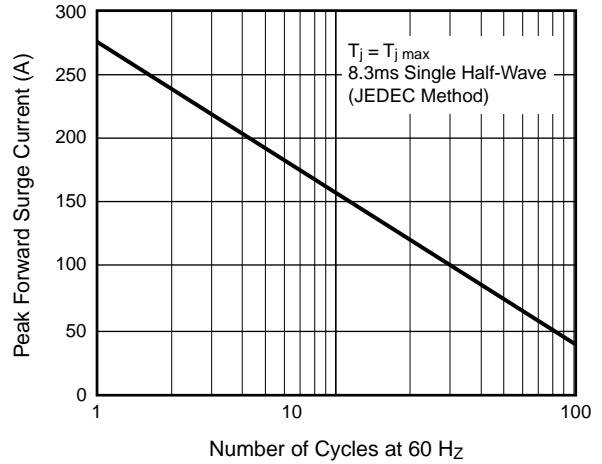

Fig. 3 – Typical Instantaneous Forward Characteristics Per Leg

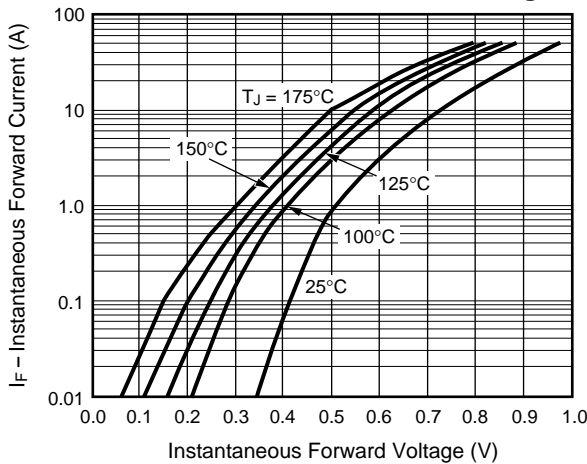

Fig. 4 – Typical Reverse Characteristics Per Leg

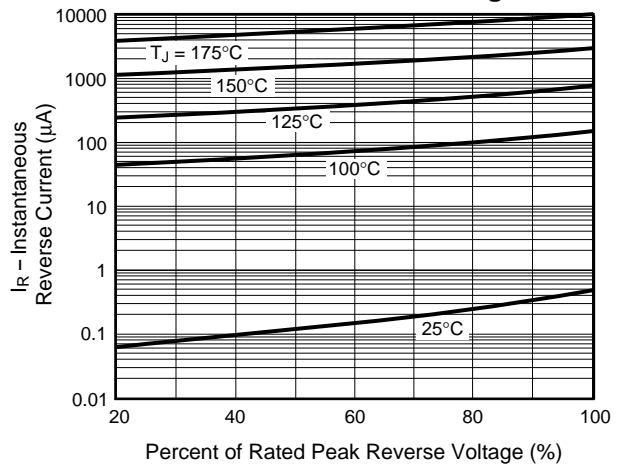

Fig. 5 – Typical Junction Capacitance Per Leg

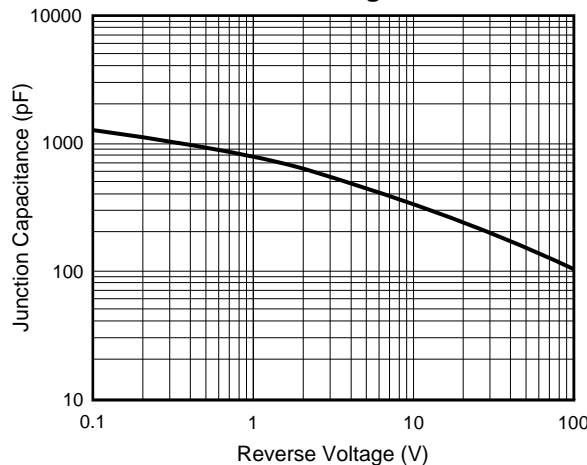

Fig. 6 – Typical Transient Thermal Impedance

